

US EPA ARCHIVE DOCUMENT

Federal Register

Friday
July 18, 1997

Part II

Environmental Protection Agency

40 CFR Part 50
National Ambient Air Quality Standards
for Particulate Matter; Final Rule

ENVIRONMENTAL PROTECTION AGENCY

40 CFR Part 50

[AD-FRL-5725-2]

RIN 2060-AE66

National Ambient Air Quality Standards for Particulate Matter

AGENCY: Environmental Protection Agency (EPA).

ACTION: Final rule.

SUMMARY: This document describes EPA's decision to revise the national ambient air quality standards (NAAQS) for particulate matter (PM) based on its review of the available scientific evidence linking exposures to ambient PM to adverse health and welfare effects at levels allowed by the current PM standards. The current primary PM standards are revised in several respects: Two new PM_{2.5} standards are added, set at 15 µg/m³, based on the 3-year average of annual arithmetic mean PM_{2.5} concentrations from single or multiple community-oriented monitors, and 65 µg/m³, based on the 3-year average of the 98th percentile of 24-hour PM_{2.5} concentrations at each population-oriented monitor within an area; and the current 24-hour PM₁₀ standard is revised to be based on the 99th percentile of 24-hour PM₁₀ concentrations at each monitor within an area. The new suite of primary standards will provide increased protection against a wide range of PM-related health effects, including premature mortality and increased hospital admissions and emergency room visits, primarily in the elderly and individuals with cardiopulmonary disease; increased respiratory symptoms and disease, in children and individuals with cardiopulmonary disease such as asthma; decreased lung function, particularly in children and individuals with asthma; and alterations in lung tissue and structure and in respiratory tract defense mechanisms. The current secondary standards are revised by making them identical in all respects to the new suite of primary standards. The new secondary standards, in conjunction with a regional haze program, will provide appropriate protection against PM-related public welfare effects including soiling, material damage, and visibility impairment. In conjunction with the new PM_{2.5} standards, a new reference method has been specified for monitoring PM as PM_{2.5}.

EFFECTIVE DATD: This action is effective September 16, 1997.

ADDRESSES: A docket containing information relating to the EPA's review of the PM primary and secondary standards (Docket No. A-95-54) is available for public inspection in the Central Docket Section of the U.S. Environmental Protection Agency, South Conference Center, Rm. 4, 401 M St.,

SW., Washington, DC. This docket incorporates the docket established for the air quality Criteria Document (Docket No. ECAO-CD-92-0671). The docket may be inspected between 8 a.m. and 3 p.m., Monday through Friday, except legal holidays, and a reasonable fee may be charged for copying. The information in the docket constitutes the complete basis for the decision announced in this document. For the availability of related information, see "SUPPLEMENTARY INFORMATION."

FOR FURTHER INFORMATION CONTACT: John H. Haines, MD-15, Air Quality Strategies and Standards Division, Office of Air Quality Planning and Standards, U.S. Environmental Protection Agency, Research Triangle Park, NC 27711; telephone: (919) 541-5533; e-mail: haines.john@epamail.epa.gov.

SUPPLEMENTARY INFORMATION:

Related Final Rules on PM Monitoring

In a separate document published elsewhere in this issue of the **Federal Register**, EPA is amending its ambient air quality surveillance requirements (40 CFR part 58) and its ambient air monitoring reference and equivalent methods (40 CFR part 53) for PM.

Availability of Related Information

Certain documents are available from the U.S. Department of Commerce, National Technical Information Service, 5285 Port Royal Road, Springfield, VA 22161.

Available documents include:

(1) Air Quality Criteria for Particulate Matter (Criteria Document) (three volumes, EPA/600/P-95-001aF thru EPA/600/P-95-001cF, April 1996, NTIS #PB-96-168224, \$234.00 paper copy).

(2) Review of the National Ambient Air Quality Standards for Particulate Matter: Policy Assessment of Scientific and Technical Information (Staff Paper) (EPA-452/R-96-013, July 1996, NTIS #PB-97-115406, \$47.00 paper copy and \$19.50 microfiche). (Add a \$3.00 handling charge per order.)

A limited number of copies of other documents generated in connection with this standard review, such as technical support documents pertaining to air quality, monitoring, and health risk assessment, can be obtained from: Environmental Protection Agency Library (MD-35), Research Triangle Park, NC 27711, telephone (919) 541-2777. These and other related documents are also available for inspection and copying in the EPA docket at the address under "ADDRESSES," at the beginning of this document.

Electronic Availability

The Staff Paper and human health risk assessment support documents are available on the Agency's Office of Air Quality Planning and Standards' (OAQPS) Technology Transfer Network (TTN) Bulletin

Board System (BBS) in the Clean Air Act Amendments area, under Title I, Policy/Guidance Documents. To access the bulletin board, a modem and communications software are necessary. To dial up, set your communications software to 8 data bits, no parity and one stop bit. Dial (919) 541-5742 and follow the on-screen instructions to register for access. After registering, proceed to choice "<T> Gateway to TTN Technical Areas", then choose "<E> CAAA BBS". From the main menu, choose "<1> Title I: Attain/Maint of NAAQS", then "<P> Policy Guidance Documents." To access these documents through the World Wide Web, click on "TTN BBSWeb", then proceed to the Gateway to TTN Technical areas, as above. If assistance is needed in accessing the system, call the help desk at (919) 541-5384 in Research Triangle Park, NC.

Implementation Strategy for Revised Air Quality Standards

On Wednesday, July 16, 1997, President Clinton signed a memorandum to the Administrator specifying his goals for the implementation of the O₃ and PM standards. Attached to the President's memorandum is a strategy prepared by an interagency Administration group outlining the next steps that would be necessary for implementing these standards. The EPA will prepare guidance and proposed rules consistent with the President's memorandum. Copies of the Presidential document are available in paper copy by contacting the U.S. Environmental Protection Agency Library at the address under "Availability of Related Information" and in electronic form as discussed above in "Electronic Availability."

The following topics are discussed in this preamble:

- I. Background
 - A. Legislative Requirements
 - B. Related Control Requirements
 - C. Review of Air Quality Criteria and Standards for PM
 - D. Summary of Proposed Revisions to the PM Standards
- II. Rationale for the Primary PM Standards
 - A. Introduction
 - B. Need for Revision of the Current Primary PM Standards
 - C. Indicators of PM
 - D. Averaging Time of PM_{2.5} Standards
 - E. Form of PM_{2.5} Standards
 - F. Levels for the Annual and 24-Hour PM_{2.5} Standards
 - G. Conclusions Regarding the Current PM₁₀ Standards
 - H. Final Decisions on Primary PM Standards
- III. Rationale for the Secondary Standards
 - A. Need for Revision of the Current Secondary Standards
 - B. Decision on the Secondary Standards
- IV. Other Issues
 - A. Consideration of Costs
 - B. Margin of Safety
 - C. Data Availability

- D. 1990 Amendments
- V. Revisions to 40 CFR Part 50, Appendix K—Interpretation of the PM NAAQS
 - A. PM_{2.5} Computations and Data Handling Conventions
 - B. PM₁₀ Computations and Data Handling Conventions
 - C. Changes that Apply to Both PM_{2.5} and PM₁₀ Computations
- VI. Reference Methods for the Determination of Particulate Matter as PM₁₀ and PM_{2.5} in the Atmosphere
 - A. Revisions to 40 CFR Part 50, Appendix J—Reference Method for PM₁₀
 - B. 40 CFR Part 50, Appendix L—New Reference Method for PM_{2.5}
- VII. Effective Date of the Revised PM Standards and Applicability of the Existing PM₁₀ Standards
- VIII. Regulatory and Environmental Impact Analyses
 - A. Executive Order 12866
 - B. Regulatory Flexibility Analysis
 - C. Impact on Reporting Requirements
 - D. Unfunded Mandates Reform Act
 - E. Environmental Justice
 - F. Submission to Congress and the Comptroller General
- IX. Response to Petition for Administrator Browner's Recusal
- X. References

I. Background

A. Legislative Requirements

Two sections of the Clean Air Act (Act) govern the establishment, review, and revision of NAAQS. Section 108 of the Act (42 U.S.C. 7408) directs the Administrator to identify certain pollutants which "may reasonably be anticipated to endanger public health and welfare" and to issue air quality criteria for them. These air quality criteria are to "accurately reflect the latest scientific knowledge useful in indicating the kind and extent of all identifiable effects on public health or welfare which may be expected from the presence of [a] pollutant in the ambient air * * *."

Section 109 of the Act (42 U.S.C. 7409) directs the Administrator to propose and promulgate "primary" and "secondary" NAAQS for pollutants identified under section 108 of the Act. Section 109(b)(1) of the Act defines a primary standard as one "the attainment and maintenance of which in the judgment of the Administrator, based on [the] criteria and allowing an adequate margin of safety, are requisite to protect the public health." The margin of safety requirement was intended to address uncertainties associated with inconclusive scientific and technical information available at the time of standard setting, as well as to provide a reasonable degree of protection against hazards that research has not yet identified. Both kinds of uncertainties are components of the risk associated with pollution at levels below those at which human health effects can be said to occur with reasonable scientific certainty. Thus, by selecting primary standards that provide an adequate margin of

safety, the Administrator is seeking not only to prevent pollution levels that have been demonstrated to be harmful but also to prevent lower pollutant levels that she finds may pose an unacceptable risk of harm, even if the risk is not precisely identified as to nature or degree. The Act does not require the Administrator to establish a primary NAAQS at a zero-risk level, but rather at a level that reduces risk sufficiently so as to protect public health with an adequate margin of safety. The selection of any particular approach to providing an adequate margin of safety is a policy choice left specifically to the Administrator's judgment. *Lead Industries Ass'n v. EPA*, 647 F.2d 1130, 1161-1162 (D.C. Cir.1980).

A secondary standard, as defined in section 109 (b)(2) of the Act, must "specify a level of air quality the attainment and maintenance of which in the judgment of the Administrator, based on [the] criteria, [are] requisite to protect the public welfare from any known or anticipated adverse effects associated with the presence of [the] pollutant in the ambient air." Welfare effects as defined in section 302(h) of the Act (42 U.S.C. 7602(h)) include, but are not limited to, "effects on soils, water, crops, vegetation, manmade materials, animals, wildlife, weather, visibility, and climate, damage to and deterioration of property, and hazards to transportation, as well as effects on economic values and on personal comfort and well-being."

Section 109(d)(1) of the Act requires periodic review and, if appropriate, revision of existing air quality criteria and NAAQS. Section 109(d)(2) of the Act requires appointment of an independent scientific review committee to review criteria and standards and recommend new standards or revisions of existing criteria and standards, as appropriate. The committee established under section 109(d)(2) of the Act is known as the Clean Air Scientific Advisory Committee (CASAC), a standing committee of EPA's Science Advisory Board.

B. Related Control Requirements

States are primarily responsible for ensuring attainment and maintenance of ambient air quality standards once EPA has established them. Under section 110 of the Act (42 U.S.C. 7410) and related provisions, States are to submit, for EPA approval, State implementation plans (SIP's) that provide for the attainment and maintenance of such standards through control programs directed to sources of the pollutants involved. The States, in conjunction with EPA, also administer the prevention of significant deterioration program (42 U.S.C. 7470-7479) for these pollutants. In addition, Federal programs provide for nationwide reductions in emissions of these and other air pollutants through the Federal Motor Vehicle Control Program under Title II of the Act (42 U.S.C. 7521-7574), which involves controls for

automobile, truck, bus, motorcycle, nonroad engine, and aircraft emissions; the new source performance standards under section 111 of the Act (42 U.S.C. 7411); and the national emission standards for hazardous air pollutants under section 112 of the Act (42 U.S.C. 7412).

C. Review of Air Quality Criteria and Standards for PM

Particulate matter is the generic term for a broad class of chemically and physically diverse substances that exist as discrete particles (liquid droplets or solids) over a wide range of sizes. Particles originate from a variety of anthropogenic stationary and mobile sources as well as from natural sources. Particles may be emitted directly or formed in the atmosphere by transformations of gaseous emissions such as sulfur oxides (SO_x), nitrogen oxides (NO_x), and volatile organic compounds (VOC). The chemical and physical properties of PM vary greatly with time, region, meteorology, and source category, thus complicating the assessment of health and welfare effects.

The last review of PM air quality criteria and standards was completed in July 1987 with notice of a final decision to revise the existing standards published in the **Federal Register** (52 FR 24854, July 1, 1987). In that decision, EPA changed the indicator for PM from total suspended particles (TSP) to PM₁₀.¹ Identical primary and secondary PM₁₀ standards were set for two averaging times: 50 µg/m³, expected annual arithmetic mean, averaged over 3 years, and 150 µg/m³, 24-hour average, with no more than one expected exceedance per year.²

The EPA initiated this current review of the air quality criteria and standards for PM in April 1994 by announcing its intention to develop a revised Air Quality Criteria Document for Particulate Matter (henceforth, the "Criteria Document"). Thereafter, the EPA presented its plans for review of the criteria and standards for PM under a highly accelerated, court-ordered schedule³ at a public meeting of the CASAC in December 1994. Several workshops were held by EPA's National Center for Environmental Assessment (NCEA) to discuss important new health effects information in November 1994 and January 1995. External review drafts of the Criteria Document were made available for public comment and were

¹ PM₁₀ refers to particles with an aerodynamic diameter less than or equal to a nominal 10 micrometers. Technical details further specifying the measurement of PM₁₀ are contained in 40 CFR part 50, Appendices J and M.

² A more complete history of the PM NAAQS is presented in section II.B of the OAQPS Staff Paper, Review of National Ambient Air Quality Standards for Particulate Matter: Assessment of Scientific and Technical Information (U.S. EPA, 1996b).

³ A court order entered in *American Lung Association v. Browner*, CIV-93-643-TUC-ACM (D. Ariz., October 6, 1994), as subsequently modified, requires publication of EPA's final decision on the review of the PM NAAQS by July 19, 1997.

reviewed by CASAC at public meetings held in August and December 1995 and February 1996. The CASAC came to closure in its review of the Criteria Document, advising the Administrator in a March 15, 1996 closure letter (Wolff, 1996a) that "although our understanding of the health effects of PM is far from complete, a revised Criteria Document which incorporates the Panel's latest comments will provide an adequate review of the available scientific data and relevant studies of PM." CASAC and public comments from these meetings, and from subsequent written comments and the closure letter, were incorporated as appropriate in the final Criteria Document (U.S. EPA, 1996a).

External review drafts of a Staff Paper prepared by the Office of Air Quality Planning and Standards (OAQPS), Review of the National Ambient Air Quality Standards for Particulate Matter: Assessment of Scientific and Technical Information (henceforth, the "Staff Paper"), were made available for public comment and were reviewed by CASAC at public meetings in December 1995 and May 1996.⁴ The CASAC came to closure in its review of the Staff Paper, advising the Administrator in a June 13, 1996 closure letter (Wolff, 1996b) that "the Staff Paper, when revised, will provide an adequate summary of our present understanding of the scientific basis for making regulatory decisions concerning PM standards." CASAC and public comments from these meetings, subsequent written comments, and the CASAC closure letter were incorporated as appropriate in the final Staff Paper (U.S. EPA, 1996b).

On November 27, 1996, EPA announced its proposed decision to revise the NAAQS for PM (61 FR 65638, December 13, 1996) (hereafter "proposal") as well as its proposed decision to revise the NAAQS for ozone (O₃) (61 FR 65716, December 13, 1996). In the proposal, EPA identified proposed revisions, based on the air quality criteria for PM, and solicited public comments on alternative primary standards and on the proposed forms of the standards.

To ensure the broadest possible public input on the PM and O₃ proposals, EPA took extensive and unprecedented steps to facilitate the public comment process beyond the normal process of providing an opportunity to request a hearing and receiving written comments submitted to the rulemaking docket. The EPA established a national toll-free telephone hotline to facilitate public comments on the proposed revisions to the PM and O₃ NAAQS, and on related notices dealing with the implementation of revised PM and O₃ standards, as well as a system for the public

to submit comments on the proposals electronically via the Internet. Over 14,000 calls and over 4,000 electronic mail messages were received through these channels. The public could also access key supporting documents (including the Criteria Document, Staff Paper, related technical documents and fact sheets) via the Internet.

The EPA also held several public hearings and meetings across the country to provide direct opportunities for public comment on the proposed revisions to the PM and O₃ NAAQS and to disseminate information to the public about the proposed standard revisions. On January 14 and 15, 1997, EPA held concurrent, 2-day public hearings in Boston, MA, Chicago, IL, and Salt Lake City, UT. A fourth public hearing, which focused primarily on PM monitoring issues, was held in Durham, NC on January 14, 1997. Over 400 citizens and organizations testified during these public hearings. EPA also held two national satellite telecasts to answer questions on the standards and participated in meetings sponsored by the Air and Waste Management Association on the proposed revisions to the standards at more than 10 locations across the country. Beyond that, several EPA regional offices held public meetings and workshops and participated in hearings that States and cities held around the country.

As a result of this intensive effort to solicit public input, over 50,000 written and oral comments were received on the proposed revisions to the PM NAAQS by the close of the public comment period on March 12, 1997. Major issues raised in the comments are discussed throughout the preamble of this final decision. A comprehensive summary of all significant comments, along with EPA's response to such comments (hereafter "Response to Comments"), can be found in the docket for this rulemaking (Docket No. A-95-54).

The principal focus of this current review of the air quality criteria and standards for PM is on recent epidemiological evidence reporting associations between ambient concentrations of PM and a range of serious health effects. Particular attention has been given to several size-specific classes of particles, including PM₁₀ and the principal fractions of PM₁₀, referred to as the fine (PM_{2.5})⁵ and coarse (PM_{10-2.5})⁶ fractions. As discussed in the Criteria Document, fine and coarse fraction particles can be differentiated by their sources and formation processes and their chemical and physical properties, including behavior in the atmosphere. Detailed discussions of atmospheric formation, ambient concentrations, and health

and welfare effects of PM, as well as quantitative estimates of human health risks associated with exposure to PM, can be found in the Criteria Document and in the Staff Paper.

D. Summary of Proposed Revisions to the PM Standards

For reasons discussed in the proposal, the Administrator proposed to revise the current primary standards for PM (as indicated by PM₁₀), by adding two new primary PM_{2.5} standards set at 15 µg/m³, annual mean, and 50 µg/m³, 24-hour average. The proposed annual PM_{2.5} standard would be based on the 3-year average of the annual arithmetic mean PM_{2.5} concentrations, spatially averaged across an area. The proposed 24-hour PM_{2.5} standard would be based on the 3-year average of the 98th percentile of 24-hour PM_{2.5} concentrations at each population-oriented monitor within an area. The proposal solicited comment on two alternative approaches for selecting the levels of PM_{2.5} standards. The Administrator also proposed to revise the current 24-hour primary PM₁₀ standard of 150 µg/m³ by replacing the 1-expected-exceedance form with a 98th percentile form, averaged over 3 years at each monitor within an area, solicited comment on an alternative proposal to revoke the 24-hour PM₁₀ standard, and proposed to retain the current annual primary PM₁₀ standard of 50 µg/m³. The proposal also solicited comment on proposed revisions to 40 CFR part 50, Appendix K to establish new data handling conventions for calculating 98th percentile values and spatial averages, revisions to 40 CFR part 50, Appendix J to modify the reference method for monitoring PM as PM₁₀, and a proposed new reference method for monitoring PM as PM_{2.5} (40 CFR part 50, Appendix L).

With regard to the secondary standards, the Administrator proposed to revise the current secondary standards by making them identical to the suite of proposed primary standards, in conjunction with the establishment of a regional haze program under section 169A of the Act.

II. Rationale for the Primary Standards

A. Introduction

1. *Overview.* This document presents the Administrator's final decisions regarding the need to revise the current primary ambient air quality standards for PM, and, more specifically, regarding the establishment of new annual and 24-hour PM_{2.5} primary standards and revisions to the form of the current 24-hour PM₁₀ primary NAAQS. These decisions are based on a thorough review, in the Criteria Document, of the latest scientific information on known and potential human health effects associated with exposure to PM at levels typically found in the ambient air. These decisions also take into account:

⁴ The Staff Paper evaluates policy implications of the key studies and scientific information in the Criteria Document, identifies critical elements that EPA staff believes should be considered, and presents staff conclusions and recommendations of suggested options for the Administrator's consideration.

⁵ PM_{2.5} refers to particles with an aerodynamic diameter less than or equal to a nominal 2.5 micrometers, as further specified in 40 CFR part 50, Appendix L in this document.

⁶ PM_{10-2.5} refers to those particles with an aerodynamic diameter less than or equal to a nominal 10 micrometers but greater than 2.5 micrometers. In other words, it refers to the inhalable particles that remain if fine (PM_{2.5}) particles are removed from a sample of PM₁₀ particles.

(1) Staff Paper assessments of the most policy-relevant information in the Criteria Document, upon which staff recommendations for new and revised primary standards are based.

(2) CASAC advice and recommendations, as reflected in discussions of drafts of the Criteria Document and Staff Paper at public meetings, in separate written comments, and in the CASAC's closure letters to the Administrator.

(3) Public comments received during the development of these documents, either in connection with CASAC meetings or separately.

(4) Extensive public comments received on the proposed decisions regarding the primary PM standards.

After taking this information and comments into account, and for the reasons discussed below in this unit, the Administrator concludes that revisions to the current primary standards to provide increased public health protection against a variety of health risks are appropriate. More specifically, the Administrator has determined that it is appropriate to establish new annual and 24-hour PM_{2.5} standards, to revise the current 24-hour PM₁₀ standard, and to retain the current annual PM₁₀ standard. As discussed more fully below in this unit, the rationale for the final decisions regarding the PM primary NAAQS includes consideration of:

(1) Health effects information, and alternative views on the appropriate interpretation and use of the information, as the basis for judgments about the risks to public health presented by population exposures to ambient PM.

(2) Insights gained from a quantitative risk assessment conducted to provide a broader perspective for judgments about protecting public health from the risks associated with PM exposures.

(3) Specific conclusions regarding the need for revisions to the current standards and the elements of PM standards (i.e., indicator, averaging time, form, and level) that, taken together, would be appropriate to protect public health with an adequate margin of safety.

As with virtually any policy-relevant scientific research, there is uncertainty in the characterization of health effects attributable to exposure to ambient PM. As discussed in the proposal, however, there is now a greatly expanded body of health effects information as compared with that available during the last review of the PM standards. Moreover, the recent evidence on PM-related health effects has undergone an unusually high degree of scrutiny and reanalysis over the past several years, beginning with a series of workshops held early in the review process to discuss important new information. A number of opportunities were provided for public comment on successive drafts of the Criteria Document and Staff Paper, as well as

for intensive peer review of these documents by CASAC at several public meetings attended by many knowledgeable individuals and representatives of interested organizations. In addition, there have been a number of important scientific conferences, symposia, and colloquia on PM issues, sponsored by the EPA and others, in the U.S. and abroad, during this period. While significant uncertainties exist, the review of the health effects information has been thorough and deliberate. In the judgment of the Administrator, this intensive evaluation of the scientific evidence has provided an adequate basis for regulatory decision making at this time, as well as for the comprehensive research needs document recently developed by EPA, and reviewed by CASAC and others, for improving our future understanding of the relationships between ambient PM exposures and health effects.

The health effects information and human risk assessment were summarized in the proposal and are only briefly outlined below in this unit. Subsequent units provide a more complete discussion of the Administrator's rationale, in light of key issues raised in public comments, for concluding that it is appropriate to revise the current primary standards (Unit II.B. of this preamble) and to revise the specific elements of the standards including indicator (Unit II.C. of this preamble); averaging time, form, and level of new PM_{2.5} standards (Units II.D., II.E., and II.F. of this preamble); and averaging time, form, and level of revised PM₁₀ standards (Unit II.G. of this preamble).

2. Summary of the health effects evidence. In brief, since the last review of the PM criteria and standards, the most significant new evidence on the health effects of PM is the greatly expanded body of community epidemiological studies. The Criteria Document stated that these recent studies provide "evidence that serious health effects (mortality, exacerbation of chronic disease, increased hospital admissions, etc.) are associated with exposures to ambient levels of PM found in contemporary U.S. urban airsheds even at concentrations below current U.S. PM standard" (U.S. EPA, 1996a; p. 13-1). Although a variety of responses to constituents of ambient PM have been hypothesized to contribute to the reported health effects, the relevant toxicological and controlled human studies published to date have not identified any accepted mechanism(s) that would explain how such relatively low concentrations of ambient PM might cause the health effects reported in the epidemiological literature.

Unit II.A. of the proposal further outlines key information contained in the Criteria Document, Chapters 10-13, and the Staff Paper, Chapter V, on the known and potential health effects associated with airborne PM, alone and in combination with other pollutants that are routinely present in the

ambient air. The information highlighted there summarizes:

(1) The nature of the effects that have been reported to be associated with ambient PM, which include premature mortality, aggravation of respiratory and cardiovascular disease (as indicated by increased hospital admissions and emergency room visits, school absences, work loss days, and restricted activity days), changes in lung function and increased respiratory symptoms, changes to lung tissues and structure, and altered respiratory defense mechanisms.

(2) Sensitive subpopulations that appear to be at greater risk to such effects, specifically individuals with respiratory disease and cardiovascular disease and the elderly (premature mortality and hospitalization), children (increased respiratory symptoms and decreased lung function), and asthmatic children and adults (aggravation of symptoms).

(3) An integrated evaluation of the health effects evidence, with an emphasis on the key issues raised in assessing community epidemiological studies, including alternative interpretations of the evidence, both for individual studies and for the evidence as a whole.

(4) The PM fractions of greatest concern to health.

The summary in the proposal will not be repeated here. EPA emphasizes that the final decisions on these standards take into account the more comprehensive and detailed discussions of the scientific information on these issues contained in the Criteria Document and Staff Paper, which were reviewed by the CASAC and the public.

3. Key insights from the risk assessment. The Staff Paper presents the results of a quantitative assessment of health risks for two example cities, including risk estimates for several categories of health effects associated with: existing PM air quality levels, projected PM air quality levels that would occur upon attainment of the current PM₁₀ standards, and projected PM air quality levels that would occur upon attainment of alternative PM_{2.5} standards. The risk assessment is intended as an aid to the Administrator in judging which alternative PM NAAQS would reduce risks sufficiently to protect public health with an adequate margin of safety, recognizing that such standards will not be risk-free. The risk assessment is described more fully in the Staff Paper and summarized in the proposal. Related technical reports and updates⁷ have

⁷ The risk assessment results that appear in the Staff Paper and are summarized in the proposal have been updated to include analyses of the particular forms of standard alternatives contained in the proposal and to correct estimates for one effects category (mortality from long-term exposure) to reflect the actual statistics used in the study upon which they were based (Pope et al., 1995). The corrections, which cumulatively reduce estimates of mortality associated with long-term exposures by 20 to 35%, have no effect on risk estimates for mortality

been placed in the docket (Abt Associates, 1996a,b; 1997a,b).

EPA emphasizes that it places greater weight on the overall conclusions derived from the studies—that PM air pollution is likely causing or contributing to significant adverse effects at levels below those permitted by the current standards—than on the specific concentration-response functions and quantitative risk estimates derived from them. These quantitative risk estimates include significant uncertainty and, therefore, should not be viewed as demonstrated health impacts. EPA believes, however, that they do represent reasonable estimates as to the possible extent of risk for these effects given the available information. Keeping in mind the important uncertainties inherent in any such analyses, the key insights from the risk assessment that are most pertinent to the current decision include:

(1) Fairly wide ranges of estimates of the incidence of PM-related mortality and morbidity effects and risk reductions associated with attainment of alternative standards were calculated for the two locations analyzed when the effects of key uncertainties and alternative assumptions were considered. Significantly, the combined analysis for these two cities alone found that the risk remaining after attaining the current PM₁₀ standards was on the order of hundreds of premature deaths each year, hundreds to thousands of respiratory-related hospital admissions, and tens of thousands of additional respiratory related symptoms in children.

(2) Based on the results from the sensitivity analyses of key uncertainties and the integrated uncertainty analyses, the single most important factor influencing the uncertainty associated with the risk estimates is whether or not a threshold concentration exists below which PM-associated health risks are not likely to occur.

(3) Over the course of a year, the few peak 24-hour PM_{2.5} concentrations appear to contribute a relatively small amount to the total health risk posed by the entire air quality distribution as compared to the aggregated risks associated with the low to mid-range concentrations.

(4) There is greater uncertainty about both the existence and the magnitude of estimated excess mortality and other effects associated with PM exposures as one considers increasingly lower concentrations approaching background levels.

associated with short-term exposures or the estimates for any other effects. Because the key sensitivity analyses that provide additional insights regarding thresholds, copollutants, averaging time and related issues involved the short-term exposure studies, none of these results are affected by changes to the long-term exposure risk estimates.

B. Need for Revision of the Current Primary PM Standards

1. *Introduction.* The overarching issue in the present review of the primary NAAQS is whether, in view of the advances in scientific knowledge reflected in the Criteria Document and Staff Paper, the existing PM standards should be revised and, if so, what revised or new standards would be appropriate. The concluding section of the integrative synthesis of health effects information in the Criteria Document, which CASAC characterized as EPA's "best ever example of a true integrative summary of the state of knowledge about the health effects of airborne PM," (Wolff, 1996b) provides the following summary of the science with respect to this issue:

The evidence for PM-related effects from epidemiological studies is fairly strong, with most studies showing increases in mortality, hospital admissions, respiratory symptoms, and pulmonary function decrements associated with several PM indices. These epidemiological findings cannot be wholly attributed to inappropriate or incorrect statistical methods, misspecification of concentration-effect models, biases in study design or implementation, measurement errors in health endpoint, pollution exposure, weather, or other variables, nor confounding of PM effects with effects of other factors. While the results of the epidemiological studies should be interpreted cautiously, they nonetheless provide ample reason to be concerned that there are detectable health effects attributable to PM at levels below the current NAAQS. [U.S. EPA, 1996a, p. 13-92]

Given the nature of the health effects in question, this finding, which is based on a large number of studies that used PM₁₀ measurements, as well as studies using other indicators of PM, clearly indicates that revision of the current PM NAAQS is appropriate. Quite apart from the issue of whether PM₁₀ should be the sole indicator for the PM NAAQS, the extensive PM epidemiological data base provides evidence of serious health effects (e.g., mortality, exacerbation of chronic disease, increased hospital admissions) in sensitive populations (e.g., the elderly, individuals with cardiopulmonary disease), as well as significant adverse health effects (e.g., increased respiratory symptoms, school absences, and lung function decrements) in children. Moreover, these effects associations are observed in areas or at times when the levels of the current PM₁₀ standards are met. Although the increase in relative risk is small for the most serious outcomes, EPA believes it is significant from an overall public health perspective, because of the large number of individuals in sensitive populations that are exposed to ambient PM, as well as the significance of the health effects involved (U.S. EPA, 1996a, p. 1-21). The results of the two-city PM risk assessment reinforce these conclusions regarding the significance of the public health risk—even under a scenario in

which the current PM₁₀ standards are attained.

While the lack of demonstrated mechanisms that explain the extensive body of epidemiological findings is an important caution, which presents difficulties in providing an integrated assessment of PM health effects research, a number of potential mechanisms have been hypothesized in the recent literature (U.S. EPA, 1996b; p. V-5 to V-8; appendix D). Moreover, qualitative information from laboratory studies of the effects of particle components at high concentrations and dosimetry considerations suggest that the kinds of effects observed in community studies (e.g., respiratory- and cardiovascular-related responses) are at least plausibly related to inhalation of PM.⁸ Indeed, as discussed in the Criteria Document and section V.E of the Staff Paper, the consistency of the results of the epidemiological studies from a large number of different locations and the coherent nature of the observed effects⁹ are suggestive of a likely causal role of ambient PM in contributing to the reported effects.

2. *Comments on scientific basis for revision.* A majority of the public comments received on the proposal agreed that, based on the available scientific information, the current PM₁₀ standards are not of themselves sufficient to protect public health and it would be appropriate to revise them. Included in those calling for revisions to the current standards are many public health professionals, including numerous medical doctors and academic researchers. For example, a group of 27 members of the scientific and medical community recognized as having substantial expertise in conducting research on the health effects of air pollution stated:

Health studies conducted in the U.S. and around the world have demonstrated that levels of particulate and ozone air pollution below the current U.S. National Air Quality Standards exacerbate serious respiratory disease and contribute to early death. A large body of scientific and medical evidence clearly indicates that the current NAAQS are not sufficiently protective of public health. [Thurston, 1997]

Similar conclusions were reached in a letter signed by more than 1,000 scientists, clinicians, researchers, and other health care professionals (Dickey, 1997). The cosigners to this letter argued that tens of thousands of hospital visits and premature deaths could be

⁸ As discussed more fully below in this unit, epidemiological studies alone cannot be used to demonstrate mechanisms of action, but they can provide evidence useful in making inferences with regard to causal relationships (U.S. EPA, 1996b, p. V-9).

⁹ As noted in the proposal, the kinds of effects observed in the epidemiological studies are logically related. For example, the association of PM with mortality is mainly linked to respiratory and cardiovascular causes, which is coherent with observed PM associations with respiratory and cardiovascular hospital admissions and respiratory symptoms. Further, similar categories of effects are seen in long- and short-term exposure studies.

prevented with the proposed air quality standard revisions. In fact, these commenters argued that even stronger standards than those proposed by EPA are needed to protect the health of the most vulnerable residents of our communities.

A number of State and local government authorities also submitted comments in support of adopting new air quality standards for fine particulate matter. The commenters concurred with conclusions reached through the EPA's peer review process that the PM standards should be revised to protect public health. A number of these commenters suggested that the standards proposed by EPA should be even stronger, while several other State agencies recommended that EPA adopt PM_{2.5} standards, but at less stringent levels. A number of the comments from states supporting even stronger standards acknowledged the lack of demonstrated mechanism(s) and other uncertainties but stressed the strength of the other evidence in urging EPA to set protective standards.

Many comments were also received from representatives of environmental or community health organizations that supported the adoption of air quality standards for PM_{2.5}. These commenters agreed with EPA's finding that a large body of compelling evidence demonstrates that exposure to particulate matter pollution, in general, is associated with premature death, aggravation of heart and lung diseases, increased respiratory illness and reduced lung function. They agreed with EPA that these studies present a consistent and coherent relationship between exposure to PM and both mortality and various measures of morbidity. However, the majority of these commenters argued that EPA's proposed standards for PM_{2.5} were inadequate and recommended adoption of more stringent levels of the 24-hour and/or annual air quality standards for PM_{2.5}. Many of these commenters also urged EPA to revise the NAAQS for PM₁₀ to be more protective of public health. These commenters based their recommendations on the findings of the studies that were reviewed in the preparation of the Criteria Document and Staff Paper. One commenter used results from five of these studies as the basis for recommending PM_{2.5} standards of 10 µg/m³ (annual) and 18 µg/m³ (24-hour) (Dockery et al., 1993; Pope et al., 1995; Schwartz et al., 1996; Schwartz et al., 1994; Thurston et al., 1994). The commenters agreed with EPA on the significance of these studies' results and the need to revise the PM standards, while differing with EPA's interpretation of the findings for purposes of developing the proposed PM standards.

Several commenters made reference to the conclusions of a number of international scientific panels regarding the health effects of exposure to airborne particulate matter—the British Expert Panel on Air Quality Standards, the British Committee on the

Medical Effects of Air Pollutants, the World Health Organization, the Canadian Ministry of Environment, Lands and Parks, and the Health Council of the Netherlands -- and argued that all these panels found that PM concentrations equivalent to the current U.S. standards for PM₁₀ are not protective of human health and made recommendations for greater protection. One commenter noted that the findings of the British Health Panel have resulted in a British proposal to adopt a 24-hour PM₁₀ standard of 50 µg/m³, which is one-third the level of the current U.S. NAAQS.

In these comments, some toxicological studies were cited as providing evidence for toxicity of particulate pollution. These commenters disagreed with arguments that PM standards cannot be adopted due to a lack of a sufficient understanding of the biological mechanism of injury. The commenters argued that there is sufficient evidence that particulate pollution is associated with adverse health effects to make it inappropriate to delay the establishment of standards while further studies are undertaken. This group of commenters was also critical of arguments against the establishment of additional PM standards based on the possibility of confounding by other pollutants, and urged that more attention be paid instead to the possible additive or synergistic effects of multiple pollutant exposures.

In general, the EPA agrees with these commenters' arguments regarding the need to revise the PM standards. The scientific studies cited by these commenters were the same studies used in the development of the Criteria Document and the Staff Paper, and the EPA agrees that there is a sufficient body of evidence that the current NAAQS for PM are not adequately protective of the public health. For reasons detailed in Unit II.F. of this preamble and in the Response to Comments, EPA disagrees with aspects of these commenters' views on the level of protection that is appropriate and supported by the available scientific information.

Another body of commenters, including almost all commenters representing businesses and industry associations, many local governmental groups and private citizens, and some States opposed revising the standards. Many of these commenters argued that the available scientific evidence does not provide an adequate basis for revising the current standards. The central arguments made by these commenters can be divided into two categories: (1) General comments on the appropriateness of relying on the epidemiological evidence for making regulatory decisions, and (2) more specific comments challenging EPA's appraisal of the consistency and coherence of the available information, EPA's conclusions regarding causality, and the use of these studies for risk assessment and decisions on whether to revise the standards. While EPA has included comprehensive responses to these comments

in the Response to Comments, certain key points are summarized below in this unit.

a. *General comments on the use of epidemiological studies.* The first category of comments was largely derived from ad hoc panels of occupational and other epidemiological experts, consulting groups, and individual consultants. Most of these individuals and groups commented on the use of epidemiology in reaching scientific and policy conclusions primarily from an occupational or hazard assessment perspective, in contrast to the perspective of the review of ambient PM criteria and standards, where the use of community air pollution epidemiological studies are central. Citing accepted criteria used in evaluating epidemiological studies to assess the likelihood of causality (most notably those of Sir Austin Bradford Hill, 1965), these commenters argued that in the absence of a demonstrated biological mechanism, the relative risks of effects in the PM epidemiological studies are too low (less than values variously cited as 1.5 to 2.0) to reach any conclusions regarding causality or to form the basis for regulations. In general, the commenters applied these criteria to a subset of studies evaluated in the Criteria Document, including as few as two long-term exposure studies (EOP Group) (API, 1997), a group of 9 selected studies (Greenland panel) (API, 1997), those studies cited in the proposal (AIHC, 1997), or as many as 23 selected short-term exposure studies examined in a recently published review paper (Gamble and Lewis, 1996).

Based on a careful review of these comments, EPA notes a number of limitations in these commenters' evaluations of the epidemiological studies that they considered, as discussed in detail in the Response to Comments. In summary, EPA notes that these commenters provided scientific advice and conclusions that are in substantial disagreement with the conclusions of the review reflected in the Criteria Document and Staff Paper. EPA stands behind the scientific conclusions reached in these documents regarding the appropriate use of the available community epidemiological studies. These documents were the product of an extended public process that included conducting public workshops involving the leading researchers in the field, drafts of the Criteria Document and Staff Paper providing opportunities for public scrutiny and comment on, and, not least, receiving the advice of an independent panel of air pollution experts, including epidemiologists.

EPA clearly specified the key criteria by which it evaluated the available epidemiological studies in section 12.1.2 of the Criteria Document, with substantial reliance on those specified by Hill (1965). In rejecting results with relative risks less than 1.5 to 2 as meaningful absent demonstrated biological mechanisms, the commenters fail to note that Hill and other expert groups (U.S.

DHEW, 1964) have emphasized that no one criterion is definitive by itself, nor is it necessary that all be met in order to support a determination of causality (U.S. EPA, 1996a, p. 12-3).

With respect to biological plausibility, Hill noted that "this is a feature I am convinced we cannot demand. What is biologically plausible depends upon the biological knowledge of the day" (Hill, 1965). This statement is clearly pertinent to the toxicological and mechanistic understanding of the effects of PM and associated air pollutants, especially at lower concentrations. It is also important to stress that while the mechanistic evidence published as of the time the Criteria Document closed does not provide quantitative support for the epidemiological results, neither can such limited evidence refute these findings. It is also important to stress that our understanding of biological mechanisms for PM pollution effects is not sufficient to explain the effects observed at much higher concentrations in air pollution episodes, for which causality is generally accepted. Moreover, the toxicological literature has only recently begun to examine animal models (or controlled human studies) that might reflect the sensitive populations in question (the elderly, individuals with chronic respiratory and cardiovascular disease) or that adequately reproduce all of the physico-chemical properties of particles in the ambient atmosphere. In short, the absence of evidence of a particular mechanism is hardly proof that there are no mechanisms that could explain the effects observed so consistently in the epidemiological studies. The absence of biological mechanisms did not deter CASAC from recommending revisions to the PM standards in 1982, 1986, and again in 1996.

While Hill appropriately emphasized the strength of the association as important (e.g., size of the relative risk), he also pointed out that "We must not be too ready to dismiss a cause-and-effect hypothesis merely on the ground that the observed association appears to be slight. There are many occasions in medicine when this in truth is so" (Hill, 1965). EPA believes that the effects of air pollution containing PM is such a case. Unlike the "textbook" examples of unlikely significant associations provided by some commenters (e.g., ice cream consumption correlated with heat stroke), the abundant epidemiological literature on combustion particles documents numerous occasions in which single short-term episodes of high air pollution produced unequivocally elevated relative risks. For the week of the well documented 1952 London air pollution episode, for example, the relative risk of mortality for all causes was 2.6, while the relative risk for bronchitis mortality was as high as 9.3 (Ministry of Health, 1954). Hospital admissions also increased by more than a factor of two. British epidemiologists in the 1950s concluded that increased

mortality was likely when PM (as mass calibrated British Smoke $4.5 \mu\text{m}$ in aerodynamic diameter) exceeded $500 \mu\text{g}/\text{m}^3$ (Martin and Bradley, 1960). This is only about a factor of 3 higher than that allowed by the current PM standard. Unlike the "textbook" and other unlikely statistical associations noted by some commenters, where the only evidence is for low relative risk, clear and convincing links between high-level PM concentrations and mortality and morbidity buttress the findings of similar associations at much lower PM concentrations as suggested in the more recent epidemiological literature.

These commenters also appear to ignore several epidemiological studies conducted at low PM concentrations in U.S. and European cities, including both short- and long-term exposures to PM air pollution, that find statistically significant relative risks of respiratory symptom categories in children in the range of 1.5 to 5 (Schwartz et al., 1994; Pope and Dockery, 1992; Braun-Fahrlander et al., 1992; Dockery et al., 1989; Dockery et al., 1996). Concentrations in these studies extend from moderately above to well below those permitted by the current PM₁₀ standards. While, as noted in the proposal, most of the recent epidemiological studies of mortality and hospital admissions report comparatively small relative risks, the findings of relative risks well in excess of the 1.5 to 2 criterion noted by commenters for earlier studies of high PM episodes, as well as the relative risks of 1.5 to 5 reported in more recent studies of less serious, but still important effects categories, lend credibility to EPA's interpretation of the results.

In addition to basing their conclusions primarily on their own assessment of a limited set of studies, this group of commenters reached different conclusions about the consistency of the observed associations because of their assumptions that all model building strategies by all authors are equally valid. Even the most thorough of these treatments (Gamble and Lewis, 1996) shared this flaw, particularly in the discussion of the series of Philadelphia mortality studies and in the discussion of modeling approaches. The authors' treatment of modeling and confounding issues was further limited because they did not include the most recent Philadelphia results (Samet et al., 1996a,b) sponsored by the Health Effects Institute (HEI, 1997). One of the important functions of the Criteria Document is to evaluate the strengths and limitations of various studies. As discussed more fully below in this unit, the Criteria Document found that some of the studies cited by commenters as suggesting a lack of consistency had important limitations. In general, these commenters' analyses suffered by ignoring the much more thorough critical review of these studies and issues contained in the Criteria Document, notably that in section 12.6 on alternative modeling approaches.

EPA also rejects the notion advanced by these commenters that epidemiological studies must use personal exposure monitoring to be considered for regulatory purposes. In particular, commenters ignore the significant strengths of the time-series studies and prospective cohort studies relied on by EPA as compared to cross-sectional epidemiological studies. Time-series studies, such as the daily mortality studies, look at changes in response rate in relation to changes in weather and air pollution over time intervals of a few days. This controls for other factors such as smoking and socioeconomic status, which are little changed during such short intervals. Prospective cohort studies (e.g., Pope et al., 1995; Raizenne et al., 1996), on the other hand, look at changes in health status in a selected cohort of individuals, which allows direct adjustment for smoking status, socioeconomic status, and other subject-specific factors. The commenters also ignore the Criteria Document conclusions on how properly conducted monitoring can provide an adequate index of population exposure to ambient air pollution in such studies that, as detailed below, is more relevant to establishing ambient air quality standards (U.S. EPA 1996a, chapter 7). Although personal monitoring may be practical for some occupational and epidemiological studies, and has been employed in some past studies of air pollution, it is not realistic to require personal monitors in air pollution studies of daily mortality, which require urban scale population data over a period of years. Furthermore, the use of community monitoring-based epidemiological studies as a basis for establishing standards and guidelines has a long history in air pollution, including the British authorities' response to the London episodes and the establishment of the original U.S. NAAQS in 1971. Rejecting the use of the vast array of such studies on this basis alone would also go against the advice of the independent scientific experts on every CASAC panel that has addressed the subject of PM pollution through the years, each of which has recommended general PM standards based primarily on the results of community epidemiological studies (Friedlander, 1982; Lippmann, 1986; Wolff, 1996b). As noted above in this unit, EPA has included a more detailed discussion of its responses to these comments in the Response to Comments.

b. *Specific comments on epidemiologic studies.* The second group of commenters noted above made more specific challenges to EPA's assessment of the epidemiological studies. These comments, although overlapping some of those made by the first group, were generally made by commenters who have taken a more active role in the review of the Criteria Document and Staff Paper. These commenters asserted that the epidemiological evidence on PM is not as

consistent and coherent as EPA has claimed, and, in particular, charged that EPA ignored or downplayed a number of studies that the commenters argue contradict the evidence the Agency cited as supporting the consistency and coherence of PM effects. The studies, all of which commenters contend do a better job of addressing one or more key issues, such as confounding pollutants, weather, exposure misclassification, and model specification, than earlier studies, include several that were available during preparation of the Criteria Document, and a number that appeared after the Criteria Document and Staff Paper were completed. Because the status of the later studies differ from that of the earlier ones for purposes of decisions under section 109 of the Act, the two categories are discussed separately below in this unit. Additional responses to comments relating to both sets of studies have been included in the Response to Comments. In addition to the inclusion of specific studies, commenters also raised other issues regarding the limitations of the epidemiological information and the use of these studies in EPA's two-city risk assessment. Both of these topics are also discussed below in this unit.

(i) *Studies available for inclusion in the criteria review.* With some exceptions, most of the above commenters cited somewhat similar lists of "negative" studies that they argue EPA ignored or downplayed in arriving at conclusions on consistency and coherence. Of the most commonly cited studies, the following were available for inclusion in the Criteria Document: daily mortality studies by Styer et al. (1995), Lyon et al. (1995), Li and Roth (1995), Moolgavkar (1995a,b), Wyzga and Lipfert (1995), Lipfert and Wyzga (1995), and Samet et al. (1995, 1996a,b); the long-term exposure mortality study by Abbey et al. (1991); and the re-examination of the Six-City mortality results (Dockery et al., 1993) by Lipfert (1995).

The written record of EPA's evaluations of these studies effectively refutes the claim that the Agency ignored any of these studies and supports the treatment the Agency accorded to each of them. All of the studies available to EPA at the time of CASAC closure on the PM Criteria Document (March 1996) were examined for inclusion in the Criteria Document and Staff Paper, which form the basis for the PM proposal. "Negative"¹⁰ studies were evaluated in detail along with "positive" studies when they were found to have no critical methodological deficiencies, or to point out strengths and limitations. Studies that had more serious problems were

¹⁰ The term "negative" studies, as used in these comments, should not be construed to mean those in which there is a negative effects estimate (either significant or non-significant) for the nominal cause. As used by these commenters, the term also includes statistically non-significant positive effect estimates. In other words, the commenters define "positive" studies as including only those in which the effect estimate is both positive and statistically significant.

generally discussed in less detail, whether positive or negative, than studies with fewer or small deficiencies. The EPA assessments were evaluated by peer reviewers, by CASAC, and by the public.

Most of the short-term exposure studies cited above in this unit are reanalyses and extensions of PM/mortality studies that had been published by other investigators. In general, the Criteria Document concluded that the most comprehensive and thorough reanalyses were those in the series conducted for the HEI, which reanalyzed data sets used in studies from six urban areas in Phase I.A (Samet et al., 1995)¹¹, with extended analyses for Philadelphia in Phase I.B (Samet et al., 1996a,b). The most important finding in the HEI Phase I.A reanalyses of the six areas is "the confirmation of the numerical results of the earlier analyses of all six data sets" (HEI, 1995)¹². After replicating the original investigators' analyses, Samet et al. (1995) also found similar results analyzing the data using an improved statistical model. The HEI Oversight Committee found

[I]t is reasonable to conclude that, in these six data sets, daily mortality from all causes combined, and from cardiovascular and respiratory causes in particular, increases as levels of particulate air pollution indexes increase. [HEI, 1995]

It is important to note that these reanalyses by respected independent scientists confirm the reliability and reproducibility of the work of the original investigators, particularly in view of the concerns some commenters have expressed about EPA's reliance on a number of PM studies published by these authors.

The Phase I.A HEI results for Philadelphia also found that it was difficult to separate the effects of PM from those of co-occurring SO₂, in agreement with the Moolgavkar et al. (1995a) analysis. Subsequent HEI work, and several of the other so-called "negative" studies cited above in this unit, further examined this issue in terms of confounding or effects modification by one or more co-occurring gaseous pollutants or weather. Contrary to commenters' claims, this issue and these studies received considerable attention in the Criteria Document and Staff Paper, and the overall implications and conclusions from these assessments were summarized in the proposal. In particular, the so-called "negative" and other findings of Moolgalvkar et al. (1995a,b) in their Philadelphia and Steubenville studies were discussed in great detail in section 12.6 of the

¹¹ Data sets were those used in the original studies by Dockery et al. (1992) for St. Louis and Eastern Tennessee; Pope et al. (1992) for Utah Valley; Schwartz and Dockery (1992a) for Philadelphia; Schwartz (1993) for Birmingham; and a portion of the Santa Clara data from Fairley (1990). The data set from the Moolgavkar et al. (1995a) Philadelphia reanalysis was also included (Samet et al., 1995).

¹² The HEI Board of Directors appointed an eight member Oversight Committee consisting of leading scientists in several disciplines relevant to air pollution epidemiology to oversee key aspects of the project and to prepare HEI's assessment of the results.

PM Criteria Document and compared to those of the original investigators (Schwartz and Dockery, 1992a,b) and other investigators (Li and Roth, 1995; Wyzga and Lipfert, 1995). Further analytical studies of the Philadelphia data set were carried out by HEI (Samet et al., 1996a,b) and have largely resolved many of the uncertainties in the earlier analyses; in EPA's opinion, these studies supersede the results of the original investigators (Schwartz and Dockery, 1992a) and the several earlier reanalyses, including Moolgavkar (1995a), Moolgavkar and Luebeck (1996), Li and Roth (1995), Wyzga and Lipfert (1995), and Samet et al. (1995). Even though TSP is not the best PM indicator for health effects, since it includes a substantial fraction of non-thoracic particles, the extended Criteria Document assessment (U.S. EPA, 1996a, pp. 12-291 to -299; 12-327) of the Phase I.B HEI analyses in Philadelphia (Samet et al., 1996a,b) serves to support the following findings:

(1) The mortality effects estimates for TSP do not depend heavily on statistical methods when appropriate models are used.

(2) Estimated PM effects are not highly sensitive to appropriate methods for adjusting for time trends and for weather.

(3) Air pollution has significant health effects above and beyond those of weather.

(4) Copollutants such as ozone, CO, and NO₂ may be important predictors of mortality, but their effects can be substantially separated from those of TSP and SO₂.

(5) The health effects of TSP in Philadelphia cannot be completely separated from SO₂, which is itself a precursor of fine particles, based solely on the epidemiological analyses in this single city.

The most recent HEI Oversight Committee comments on these studies (HEI, 1997), which were submitted to the docket by HEI, state that:

Although individual air pollutants (TSP, SO₂, and ozone) are associated with increased daily mortality in these data, the limitations of the Philadelphia data make it impossible to establish that particulate air pollution alone is responsible for the widely observed associations between increased mortality and air pollution in that city. All we can conclude is that it appears to play a role. [HEI, 1997; p.38.]

While recognizing the limitations in the conclusions that can be made based on studies in a single city, the Oversight Committee endorses the approach taken by EPA in evaluating a broader set of epidemiological studies:

Consistent and repeated observations in locales with different air pollution profiles can provide the most convincing epidemiological evidence to support generalizing the findings from these models. This has been the approach reported by the EPA in its recent Criteria Document and Staff Paper. [HEI, 1997; p. 38.]

As noted in the proposal, based on this approach, EPA's assessment of numerous mortality studies concludes that when studies

are evaluated on an individual basis, the PM-effects associations are valid and, in a number of studies, not seriously confounded by co-pollutants (U.S. EPA, 1996a; p. 13-57); and when a collection of studies from multiple areas with differing concentrations of PM and co-pollutants are examined together, the association with PM₁₀ remains reasonably consistent across a wide range of concentrations of these potentially influential pollutants (U.S. EPA, 1996a; p. 12-33; U.S. EPA, 1996b; p. V-55).

In addition to relying on the most comprehensive and best analyses in evaluating the reanalysis in Philadelphia and other areas, the Criteria Document gave less weight to both so-called "negative" and "positive" studies with methodological limitations. In particular, EPA agreed with the epidemiological experts on CASAC (Lippmann et al., 1996; Samet, 1995) that the Li and Roth (1995) study approach of using a "panoply" of different modeling strategies to produce seemingly conflicting findings provides little useful insight and is superseded by the HEI report. The attempt by Lipfert and Wyzga (1995) to address relative effects of different pollutants was considered inconclusive (Lippmann et al., 1996) and flawed by the use of a metric (elasticity) that ignores the absolute concentrations of the pollutants being compared (see Response to Comments).

Further, the Steubenville studies and reanalyses (Schwartz and Dockery, 1992b; Moolgavkar, 1995b) were discussed in detail to examine methodologies, and the differences in relative risks between the two were regarded as small (U.S. EPA, 1996a, p. 12-280 to 283). Both studies used TSP as the PM indicator variable, and they are augmented by the more recent findings of Schwartz et al. (1996) that examine PM₁₀ and its components. The mixed results by Lyon et al. (1995) in Utah Valley are compromised by loss of information related to the methodology (U.S. EPA, 1996a, p. 12-58). As noted above, subsequent reanalyses of the Utah Valley study by HEI (Samet et al., 1995) as well as by Pope and Kalkstein (1996) confirmed the original findings of Pope et al. (1992) using different model specifications. The Salt Lake City study by Styer et al. (1995) was mentioned in the PM Criteria Document, but received little discussion because aspects of the methodological approach limited its statistical power to detect effects. The analysis of Chicago mortality data in the same paper shared these problems, particularly for seasonal analyses; in this larger city, they nonetheless found significant associations on an annual basis between PM₁₀ and mortality that are consistent with other studies. In short, the record shows that EPA did not ignore these short-term exposure studies cited by commenters; moreover, EPA's assessment of these studies is consistent with the views of four researchers on the CASAC panel who

have extensive involvement in conducting population studies of air pollution (Lippmann et al., 1996).¹³

Similarly, EPA believes that appropriate treatment and weight were given to studies of long-term exposure and mortality. EPA concluded that the lack of associations in the Abbey et al. (1991) prospective cohort study were not inconsistent with two other such studies because the use of days of peak TSP levels as the PM indicator (instead of PM₁₀ or PM_{2.5}) is inappropriate for California cohorts exposed to both urban smog and fugitive dust episodes, and the overall sample size may have been too small to detect significant effects (U.S. EPA, 1996b; pp. V-17 to -18). The inadequacy of Lipfert's (1995) application of state-wide average sedentary lifestyle data to adjust mortality for the six cities studied by Dockery et al. (1993), in which superior subject-specific body mass index data had already been considered, was also noted and addressed in the Staff Paper (U.S. EPA, 1996b; p. V-16). Again, EPA did not ignore these studies; the rationale for giving them less weight was clearly articulated in the documents reviewed by CASAC and judged appropriate for use in standard setting.

While the proposal presents only a summary discussion of key Criteria Document and Staff Paper findings, EPA believes that discussion is fully consistent with the state of the science. Furthermore, the proposal highlights the nature of alternative viewpoints on the epidemiology in a quotation from the Criteria Document (61 FR 65644, December 13, 1996) and cites explicitly the views of most of the authors noted above in this unit (Moolgavkar et al., 1995b; Moolgavkar and Luebeck, 1996; Li and Roth, 1995; Samet et al., 1996; Wyzga and Lipfert, 1995). The proposal also summarizes EPA conclusions based on all of the literature as assessed in the Criteria Document and Staff Paper with respect to issues raised in these and other studies, including potential confounding by independent risk factors such as weather and other pollutants, choice of statistical models, use of outdoor monitors, and exposure misclassification.

More specifically, in the proposal EPA has not ignored the view advanced by some that the results of individual studies of multiple pollutants, such as the HEI Philadelphia studies, are more suggestive of an "air pollution" effect than an effect of PM alone. Indeed, the proposal notes that it is reasonable to expect that other pollutants may play a role in modifying the magnitude of the estimated effects of PM on mortality, either through pollutant interactions or independent effects (61 FR 65645, December 13, 1996). Based on

¹³ Their March 20, 1996 letter to the Administrator concludes that the HEI analysis of Philadelphia supersedes earlier analyses, specifically Moolgavkar et al. (1995a), Lipfert and Wyzga (1995), and Li and Roth (1995), and points out the limitations of Styer et al. (1995).

the large body of evidence at hand, however, EPA cannot accept the suggestion that such multi-pollutant studies are in any way "negative" with respect to EPA's conclusions that PM, alone or in combination with other pollutants, is associated with adverse effects at levels below those allowed by the current standards. This conclusion is based not only on the consistency of PM effects across areas with widely varying concentrations of potentially confounding copollutants, but also on the extended analyses of the Philadelphia studies in the Criteria Document and Staff Paper.

Because commenters have tended to ignore the latter analyses, it is appropriate to summarize them here briefly. As noted above in this unit, the Criteria Document assessment of the Philadelphia studies finds that PM can reasonably be distinguished from potential effects of all pollutants except SO₂. The Staff Paper builds on this analysis through an integrated assessment that draws on information from atmospheric chemistry, human exposure studies, and respiratory tract penetration results to provide insight as to which of these two pollutants is more likely to be responsible for mortality in the elderly and individuals with cardiopulmonary disease (U.S. EPA 1996b; pp. V-46 to -50). That assessment notes that the inhalable (PM₁₀), including the fine (PM_{2.5}), components of TSP are more likely than SO₂ to penetrate and remain indoors where the sensitive population resides most of the time.¹⁴ In addition, these PM components, especially PM_{2.5}, penetrate far more effectively to the airways and gas exchange regions of the lung than does SO₂. Furthermore, in Philadelphia, it is possible that SO₂ is a surrogate for fine particulate acid sulfates. For these reasons, even though statistical analyses of the Philadelphia data set cannot fully distinguish between these two highly correlated pollutants, EPA believes that the weight of the available evidence from an integrated assessment more strongly supports the notion that PM is playing an important direct role in the observed mortality effects associations in Philadelphia. Moreover, as noted above in this unit, in some other locations with significant PM-mortality associations, ambient SO₂ levels are too low to confound PM.

(ii) *Recent studies available after completion of criteria review.* As noted above in this unit, other studies cited by some commenters as so-called "negative" evidence ignored by EPA were published or otherwise made available only after completion of the PM Criteria Document. EPA agrees that it did not rely on these

¹⁴ In response to comments on this rulemaking, some papers submitted by industry commenters make statements that are in substantial agreement with these staff conclusions with respect to the likelihood of SO₂ penetrating to indoor environments and the lesser likelihood of affecting sensitive populations indoors (Lipfert and Wyzga, 1997; Lipfert and Urch, 1997).

studies, based on its long-standing practice of basing NAAQS decisions on studies and related information included in the pertinent air quality criteria and available for CASAC review.¹⁵ Although EPA has not relied on such studies in this review and decision process, the Agency nevertheless has conducted a provisional examination of these and other recent studies to assess their general consistency with the much larger body of literature evaluated in the Criteria Document.¹⁶ EPA has placed its examination of recent studies in the rulemaking docket.

Among the most frequently cited new studies relied on by commenters were Davis et al. (1996), Moolgavkar et al. (1997), and Roth and Li (1997). Davis et al. (1996) conducted a reanalysis of the Birmingham mortality data set originally investigated in Schwartz (1993). At the time of the close of the public comment period, the paper based on this manuscript had not been accepted for publication in a peer reviewed journal (Sacks, 1997). Commenters nevertheless highlight the authors' claim that "when humidity is included among the meteorological variables (it is excluded in the analysis by Schwartz [1993]), we find that the PM₁₀ effect is not statistically significant." EPA's review found important factual errors in this study. Contrary to Davis et al., Schwartz did include humidity in his 1993 study, and his finding of a hot-and-humid-day effect was reported there. In addition, the PM-related variables used by Davis et al. in their manuscript were not, as the authors claimed, the same as those in Schwartz (1993). Davis et al. also used a different humidity indicator, specific humidity. Reanalysis by one of the co-authors (R. Smith, personal communication, February

8, 1997) showed that when Schwartz's PM metric was used, the estimated PM₁₀ effect was of about the same magnitude, and statistically significant at the 0.05 level, even using the characterization of humidity effect proposed by Davis et al. It therefore appears that the Davis et al. PM₁₀ result was, in fact, consistent with that of Schwartz, and robust against a very different weather model specification.

Based on its examination of both the content and the publication status of this study, EPA believes the heavy reliance and attention given to it are misguided. In contrast to commenters' assertions, this study does not contradict EPA's conclusions with respect to consistency of the epidemiological evidence and confounding by weather variables; indeed, the consideration of the corrected results would actually support EPA's conclusions. EPA believes this example reinforces the importance of relying on peer reviewed studies and also conducting the kind of critical examination of such studies that takes place in the criteria and standards review process.

Several commenters note that Roth and Li (1997) also reexamined the Birmingham mortality data, as well as hospital admissions data from Schwartz (1994), and produced a number of negative and inconsistent results that depend on temperature effects and choice of statistical model. Preliminary findings from this study were presented by Roth at the May 1996 CASAC meeting. CASAC epidemiologists and statisticians at the meeting pointed out a number of shortcomings, both in the analytical strategy and in details of the models being evaluated.¹⁷ As discussed in more detail in the Response to Comments, the materials from Roth and Li (1997) recently provided to EPA as attachments to public comments show that the deficiencies pointed out at the May 1996 CASAC meeting have not been adequately addressed. EPA concludes that this study does not support commenters' claims.

The paper recently accepted for publication by Moolgavkar et al. (1997) examines hospital admissions and air pollution in Minneapolis and Birmingham and comes to different conclusions than earlier investigators with respect to the role of PM₁₀. While the paper is a useful addition to the literature, the authors clearly do not attempt to replicate the original studies, making the kind of direct comparisons suggested by commenters

difficult. The paper finds an air pollution effect in one city that implicates ozone but is unable to separate effects of PM from a group of other pollutants. EPA's provisional examination of this study raises some questions about the methodology, which might usefully be supplemented to further separate pollutants as was done by Samet et al. (1996a,b) in Philadelphia, and about the authors' interpretation of the results in both cities. In any event, EPA does not believe this study negates the PM associations with hospital admissions reported in a number of other studies cited in the Criteria Document.

Another recent paper by Lipfert and Wyzga (1997) provides analyses suggesting that differential measurement error might account for some or all of the observation by Schwartz et al. (1996) that daily mortality is more strongly associated with fine (PM_{2.5}) than with coarse (PM_{10-2.5}) PM. EPA staff and CASAC accounted for this possibility, however, and it was factored into both the Staff Paper and CASAC recommendations.¹⁸

Some commenters have highlighted selected individual papers or summaries from the APHEA¹⁹ project conducted in Europe, and from Roth (1996), calling attention particularly to negative results found in heavily polluted regions of Eastern Europe. EPA notes that a number of the recent APHEA and other studies in Western Europe have shown significant associations between mortality and air pollution including PM, and that a meta-analysis of 12 Western and Central-eastern European studies "is supportive of a causal association between PM and SO₂ exposure and all-cause mortality" (Katsouyanni et al., 1997). The Eastern and Western European studies used differing measurement methods for PM, including PM₁₀, gravimetric "suspended

¹⁵ Since the 1970 amendments, the EPA has taken the view that NAAQS decisions are to be based on scientific studies that have been assessed in air quality criteria [see e.g., 36 FR 8186 (April 30, 1971) (EPA based original NAAQS for six pollutants on scientific studies discussed in the air quality criteria and limited consideration of comments to those concerning validity of scientific basis); 38 FR 25678, 25679-25680 (September 14, 1973) (EPA revised air quality criteria for sulfur oxides to provide basis for reevaluation of secondary NAAQS)]. This longstanding interpretation was strengthened by new legislative requirements enacted in 1977 (section 109(d)(2) of the Act; section 8(c) of the Environmental Research, Development, and Demonstration Authorization Act of 1978) for CASAC review of air quality criteria and reaffirmed in EPA's decision not to revise the ozone standards in 1993. 58 FR 13008, 13013-13014 (March 9, 1993). Some of the commenters now criticizing EPA for not considering the most recent PM studies strongly supported the Agency's interpretation in the 1993 decision (UARG, 1992).

¹⁶ As discussed in EPA's 1993 decision not to revise the NAAQS for ozone, new studies may sometimes be of such significance that it is appropriate to delay a decision on revision of NAAQS and to supplement the pertinent air quality criteria so the new studies can be taken into account. 58 FR at 13014, March 9, 1993. In the present case, EPA's provisional examination of recent studies suggests that reopening the air quality criteria review would not be warranted even if there were time to do so under the court order governing the schedule for this rulemaking. Accordingly, EPA believes that the appropriate course of action is to consider the newly published studies during the next periodic review cycle.

¹⁷ For example, commenting on the Roth examination of alternative model specifications, Dr. Stolwijk noted "If you select out of his [Roth's] matrix the things that other people have done, he comes to a different conclusion than when he takes his whole matrix * * *. [Y]ou are going to get a random effect that shows that there is no effect. He [Roth] did this, I think, on purpose in this case. Most epidemiologists, I think, have been trained to limit their observations to something that they can state or would have stated before they started and observe that and base their conclusions on it" [U.S. EPA 1996(c); May 17, 1996 Transcript, pages 45-46].

¹⁸ CASAC panelists recommended a discussion of this issue in the Staff Paper. The Staff Paper notes: "While greater measurement error for the coarse fraction could depress a potential coarse particle effect, this would not explain the results in Topeka relative to other cities. Even considering relative measurement error, these results provide no clear evidence implicating coarse particles in the reported effects." (U.S. EPA, 1996b p. V-64). EPA's provisional examination of the Lipfert and Wyzga (1997) paper in the Response to Comments, finds that it is implausible that most of the effect attributed to PM_{2.5} could in fact be due to PM_{10-2.5}, since differential measurement error cannot make a weaker effect appear stronger than a stronger one, except under extremely unusual circumstances.

¹⁹ The APHEA (Air Pollution and Health: a European Approach) project was supported by the European Union Environment 1991-1994 Programme to investigate the possible short-term health effects of exposure to low or moderate levels of ambient air pollutants. Eleven European research groups carried out studies in 15 cities (Amsterdam, Athens, Barcelona, Bratislava, Cracow, Helsinki, Koln, Lodz, London, Lyon, Milan, Paris, Poznan, Rotterdam and Wroclaw) in which air pollutant concentration data had been collected for at least 5 years. Initial findings of studies on mortality and hospital admissions were published in a series of papers in Supplement 1 to the Journal of Epidemiology and Community Health in 1996 and a meta-analysis of the mortality data from 12 cities is currently in press (Katsouyanni et al., 1997).

particles," and the British Smoke method.²⁰ The differences in aerometry and the substantial differences in location and strength of primary PM emissions sources in central and eastern Europe as compared to western Europe or the U.S. might well explain the different results in these unique areas. Consequently, integration of these results would involve comprehensive examination of the various PM instruments used, monitor siting in relation to sources, mass calibration procedures and other aspects of these studies.²¹ EPA notes that a number of European authorities, who are familiar with this recent literature, have proceeded with recommendations to strengthen their health guidelines, risk assessments, or regulations for PM.²²

Aside from the recent literature cited by these commenters, there are a number of other recent epidemiological studies that, if considered in today's decision, would tend to support EPA's conclusions about the effects of PM at lower concentrations, assuming their results were accepted following a full review in the criteria and CASAC process. For example, in addition to the APHEA studies, several other recent epidemiologic studies have reported significant positive associations between PM and health effects (Lipsett et al., 1997; Peters et al., 1997; Borja-Aburto et al., 1997; Delfino et al., 1997; Scarlett et al., 1996; Woodruff et al., 1997; Wordley et al., 1977). In addition, a number of recent toxicologic papers have been accepted or appear in proceedings (Costa and Dreher, 1997; Killingsworth et al., 1997; Godleski et al., 1997) that involve exposure to concentrated ambient fine particles or PM constituents and appear to provide supportive evidence as to the plausibility of the effects that have been reported epidemiologically. If considered in this decision, these studies would also provide biological support for the epidemiological observation that certain susceptible groups (notably those with cardiopulmonary disease) are most likely to be affected by PM, again assuming the results were sustained in the full criteria and CASAC review process.

²⁰ The Roth et al. (1997) study in Prague used a measurement termed "suspended particles" that appears to be close to TSP. The relation of this indicator to PM₁₀ or PM_{2.5} in this city is not reported. Moreover, this study uses a variant of the problematic methodology in the Roth analyses cited above.

²¹ These concerns are consistent with EPA's treatment of a number of European and South American studies that are included in the Criteria Document and contributed to the evaluation of the epidemiology in Chapter 12. Because of differences in aerometry methods and characteristic source classes between North America and other regions of the world, however, the integrative assessment chapter reported results only from studies conducted in the U.S. and Canada (cf. Tables 13-3 to 13-5) in reaching quantitative conclusions for effects estimates.

²² See, for example, the United Kingdom Air Quality Strategy, 1997; Swiss Federal Commission of Air Hygiene, 1996; World Health Organization Revised Air Quality Guidelines for Europe, In Press).

In summary, EPA has conducted a provisional assessment of the more recent scientific literature. Based on this provisional assessment, EPA disagrees with commenters' assertion that full consideration of selected new studies in this decision would materially change the Criteria Document and Staff Paper conclusions on the consistency and coherence of the PM data, or on the need to revise the current standards.

(iii) *Other specific comments on the epidemiological studies.* Aside from their assertion that EPA ignored or downplayed particular studies, this second group of commenters raise additional objections, based on the statistical modeling strategies used and the potential importance of personal exposure misclassification, to EPA's conclusions regarding the consistency of the epidemiological evidence. EPA conclusions on these topics were summarized in the proposal and supported by extensive treatments in the Criteria Document and Staff Paper. With respect to the first issue, commenters argued that sufficient flexibility exists in the analyses of large data sets that it may be possible to obtain almost any result desired through choice of statistical method. Analytical choices include the specific statistical model; methods used to adjust for seasonal variation and the trends in the data; treatment of other variables (e.g., other pollutants, weather, and day of week); "lag" structure; and study population.

A more detailed discussion of this issue, which expands on the assessment summarized in the Criteria Document, is included in the Response to Comments. In summary, EPA must reject commenters' contention that legitimate alternative analyses can obtain "almost any result." As outlined above in this unit, EPA's detailed reviews of individual studies have shown that not all methods are equally valid or legitimate. Moreover, strong arguments can be made that the methods and analytical strategies in the studies EPA relied upon are more appropriate approaches than those cited by commenters (e.g., Li and Roth, 1995; Lipfert and Wyzga, 1995; Davis et al., 1996; Roth and Li, 1997). While not all studies have addressed each of the above issues in this unit equally well, the most comprehensive analyses of these issues (e.g., Samet et al., 1995, 1996a,b; Pope and Kalkstein, 1996), as well as the EPA analyses comparing study results for each issue (U.S. EPA, 1996a, pp. 12-261 to 12-305) found that the authors of studies on which EPA chiefly relied made appropriate modeling choices. The Criteria Document concludes that: "[T]he largely consistent specific results, indicative of significant positive associations of ambient PM exposures and human mortality/morbidity effects, are not model specific, nor are they artifactually derived due to misspecification of any specific model. The robustness of the results of different modeling strategies and approaches increases our confidence in their validity [U.S. EPA, 1996a,

p. 13-54]." While it is true, as evidenced in Li and Roth (1995), that PM-effects data can be randomly manipulated to produce apparently conflicting results, commenters have provided no evidence that different plausible model specifications could lead to markedly different conclusions.

Some commenters have expressed concerns about the reliability of the epidemiological results because some studies showed a lack of correlation in cross-sectional comparisons between outdoor PM measured at central locations and indoor or personal exposures to PM (which includes PM from the outdoor, indoor and personal environments).²³ EPA acknowledged and responded to this issue in chapter 7 of the Criteria Document and the proposal (61 FR 65645, December 13, 1996). The major premise underlying commenters' arguments on this issue is incorrect.²⁴ The question is not whether central monitoring site measurements contain a signal reflecting actual exposures to total PM from both outdoor and indoor sources at the individual level; the relevant question is whether central monitoring site measurements contain a signal reflecting actual exposures to ambient PM for the subject population, including both ambient PM, while individuals are outdoors, and ambient PM that has infiltrated indoors, while individuals are indoors. The PM standards are intended to protect the public from exposure to ambient PM, not PM generated by indoor or personal sources. There is ample evidence, as discussed in chapter 7 of the Criteria Document, that personal exposure to ambient PM, while

²³ Paradoxically, some commenters have argued (e.g., Valdberg, 1997) that the PM results are confounded because the weather and other factors that cause daily variations in outdoor pollution will cause similar daily variations in indoor generated air pollution. For this to be true, outdoor ambient pollution concentrations would have to be correlated with personal exposure to indoor generated air pollution such as that from smoking, cleaning, and cooking. This argument is logically inconsistent with the other comments on the lack of any such correlation with personal exposure, and these commenters have offered no scientific evidence to support their claim. In response, EPA has performed and included in the Response to Comments a numerical analysis of the relevant information from the PTEAM exposure study that finds no evidence for such a correspondence in the actual data.

²⁴ As documented in Chapter 7 of the Criteria Document, time-series community studies observe the effects of varying levels of ambient air pollution; therefore the effects of indoor-generated air pollution would be independent of and in addition to the effects found in these epidemiological studies. Commenters apparently believe EPA is claiming such studies are detecting the effects of daily variations in total PM personal exposure from indoor and outdoor sources. This misunderstanding is evidenced, for example, by Wyzga and Lipfert's (1995) treatment of the difference between ambient monitors and actual personal exposures as "exposure errors" and Brown's comment for API that "if (ambient) PM is causally related to mortality/morbidity, then it is personal PM exposure that must be reduced to have an effect." On the contrary, it is personal exposure to ambient PM that must be reduced to address the risk identified in community air pollution studies. Any lack of significant correlation between outdoor PM concentrations and personal exposure to total PM from all sources is irrelevant, except to the extent it may decrease the power of time-series studies to detect the effects of ambient pollution.

outdoors and while in indoor micro-environments, does correlate on a day-to-day basis with concentrations measured at properly sited central monitors (U.S. EPA, 1996a, p. 1-10). EPA has, therefore, concluded that it is reasonable to presume that a reduction in ambient PM concentrations will reduce personal exposure to ambient PM, and that this will protect the public from adverse health outcomes associated with personal exposure to ambient PM.

Commenters have also restated theoretically based concerns on a related issue, namely errors in the measurement of the concentrations of air pollutants, that was summarized in the proposal. In multiple pollutant analyses, measurement error or, more generally, exposure misclassification, could theoretically bias effects estimates of PM or co-pollutants in either direction, introducing further uncertainties in the estimated concentration-response relationships for all pollutants (U.S. EPA, 1996b, pp. V-39 to V-43). Relevant insights on this issue in material appended to public comments (Ozkaynak and Spengler, 1996) have prompted an expanded statistical analysis of the conditions under which such errors could inflate the magnitude of the effects estimates or the significance of PM relative to gaseous pollutants, as has been suggested by Lipfert and Wyzga (1995). This analysis, which is summarized in the Response to Comments, finds that the conditions under which measurement error could inflate the effects estimates or significance of PM relative to other pollutants are restricted to a limited set of statistical relationships. Commenters have not provided evidence that suggest such conditions are likely to occur with respect to the measurement of ambient PM in relation to those for gaseous co-pollutants commonly used in epidemiological studies.²⁵ Therefore, it appears unlikely that measurement and exposure errors for PM and other pollutants have inflated the estimated effects of PM, even in multivariate analyses. More importantly, the available evidence on the consistency of the PM-effects relationships in multiple urban locations, with widely varying indoor/outdoor conditions and a variety of monitoring approaches, makes it less likely that the observed associations of PM with serious health effects at levels allowed under the current NAAQS are an artifact of errors

in measurement of pollution or of exposure (U.S. EPA 1996b, pp. V-39 to V-43).

(iv) *Comments on the PM risk assessment.* As noted in the proposal, uncertainties about measurement errors, exposure misclassification, and the relative effects of copollutants are more important to the quantitative estimates of risk associated with PM than to the existence of valid PM-effects associations at levels found in recent studies. A number of commenters argued that EPA's risk assessment is flawed and incomplete. Chief among the reasons they advanced is that the assessment is based on the same epidemiological studies these commenters argued are inadequate for the reasons summarized and responded to above. Specific comments also addressed the extent to which the risk assessment might overstate risk estimates because it assumes a linear no-threshold relationship and the use of studies that might inflate PM risk due to inadequate consideration of co-pollutants and other potential confounders. The full risk assessment acknowledges these issues and uncertainties, however, and it illustrates the potential influence of such uncertainties in sensitivity analyses (U.S. EPA 1996b; chapter 6, appendix F; Abt Associates, 1996a,b; 1997a,b). For example, Figure 2c in the proposal (61 FR 65653, December 13, 1996) illustrates the potential influence of what appears to be the most significant uncertainty in current information, whether a population threshold exists below which the effects of PM no longer occur (61 FR 65653, December 13, 1996). EPA notes that a full consideration of the uncertainties, including the analysis summarized above on measurement error, suggests that the epidemiological studies might well have understated the total effects of air pollution; thus, both the direction and the extent of any bias in the risk estimates are less clear than commenters suggest.

EPA believes that, even recognizing the large uncertainties, the key qualitative insights derived from the risk assessment and summarized in Unit II.A.3. of this preamble remain appropriate. While not placing great weight on the specific numerical estimates, EPA believes that the risk analysis confirms the general conclusions drawn primarily from the epidemiological results themselves, that there is ample reason to be concerned that exposure to ambient PM at levels allowed under the current air quality standards presents a serious public health problem.

3. *Key considerations informing the decision.* Having carefully considered the public comments on the above matters, EPA believes the fundamental scientific conclusions on the effects of PM reached in the Criteria Document and Staff Paper, and restated in the introduction to this unit, remain valid. That is, the epidemiological evidence for ambient PM, alone or in combination with other pollutants, shows associations with premature mortality, hospital admissions, respiratory symptoms,

and lung function decrements. Despite extensive critical examination in the criteria and standards review, these findings cannot be otherwise explained by analytical, data, or other problems inherent in the conduct of such studies. Although the evidence from toxicological studies available during the criteria review has not revealed demonstrated mechanisms that explain the range of effects reported in epidemiological studies, it does not and cannot refute the observation of such effects in exposed populations. Moreover, the effects observed in the recent epidemiological studies at lower PM concentrations are both coherent with each other and plausible based on the categories of effects observed at much higher concentrations in historic air pollution episodes, laboratory studies of PM effects at high doses, and particle dosimetry studies. The consistency of the results from a large number of locations and the coherent nature of the observed results suggest a likely causal role of ambient PM in contributing to the reported effects (U.S. EPA, 1996a; p. 13-1). Many of the studies showing PM effects were conducted in areas where the current PM₁₀ standards are largely met, and both the studies and EPA's risk assessment suggest that the collective magnitude of the effects reflects a significant public health problem.

For these reasons, and having considered public comments on this issue, the Administrator concludes that the review of the criteria and standards provides strong evidence that the current PM₁₀ standards do not adequately protect public health, and that revision of the standards is not only appropriate, but necessary.

Aside from that conclusion, the appropriateness of continuing to rely on the use of PM₁₀ as the sole indicator for revised PM standards is also relevant here. While the basis for decisions on specific indicators is discussed more fully in Unit II.C. of this preamble, this issue is related to the Administrator's decision on the need to revise the standards. Based on both the staff review (U.S. EPA, 1996b, p. VII-3) and the recommendations of some commenters (e.g., California EPA), there are two alternative approaches for providing additional health protection in revising the standards: Adopt tighter PM₁₀ standards and/or recognize the fundamental differences between fine and coarse particles and develop separate standards for the major components of PM₁₀, including fine particles. Conceptually, the first approach would give weight to comments that standards should be based on pollutant indicators for which the most data have been collected, with less consideration of the evidence that suggests that the current standards provide adequate protection against the effects of coarse particles, and that tightening the current PM₁₀ standards in an attempt to control fine particles would place unnecessary requirements on coarse particles. Because the PM₁₀ network is in place, a more stringent PM₁₀ standard would also respond

²⁵ The EPA analysis finds that in order for measurement errors in one pollutant variable to significantly bias the estimated effect of another pollutant, three conditions are necessary: (1) The measurement error in the poorly measured pollutant must be very large, roughly at least the same size as the population variability in that pollutant; (2) the poorly measured pollutant must be highly correlated with the other pollutant, either positively or negatively; and (3) the measurement errors for the two pollutants must be highly negatively correlated (Response to Comments, Appendix D). This important factor was not considered in Lipfert and Wyzga (1995) or by commenters.

to commenters who have expressed a desire for more immediate implementation of revised standards. The second approach is based on the view that, in the long run, more effective and efficient protection can be provided by separately targeting appropriate levels of controls to fine and coarse PM.

The Staff Paper examined this issue in detail (U.S. EPA 1996b, pp. VII-3 to VII-11), and concluded that the available information was sufficient to develop separate indicators for fine and coarse fractions of PM₁₀, based on the recent health evidence, the fundamental differences between fine- and coarse-fraction particles, and implementation experience with PM₁₀. Further, the staff concluded that:

[C]onsideration of comparisons between fine and coarse fractions suggests that fine fraction particles are a better surrogate for those particle components linked to mortality and morbidity effects at levels below the current standards. In contrast, coarse fraction particles are more likely linked with certain effects at levels above those allowed by the current PM₁₀ standards. In examining alternative approaches to increasing the protection afforded by PM₁₀ standards, the staff concludes that reducing the levels of the current PM₁₀ standards would not provide the most effective and efficient protection from these health effects. [U.S. EPA 1996b; p. 7-45]

As discussed in Unit II.C. of this preamble, the Administrator believes that it is more appropriate to provide additional protection against the risk posed by PM by adding new standards for the fine fraction of PM₁₀, as opposed to tightening the current PM₁₀ standards. Although fewer epidemiological studies have used PM_{2.5} and other fine particle indicators (e.g., sulfates, acids), there are nonetheless significant indications from the scientific evidence - drawn from the physicochemical studies of PM, air quality and exposure information, toxicological studies, and respiratory tract deposition data - that this approach will provide the most effective and efficient protection of public health.

Several commenters have argued that the decision on whether to revise the PM standards should be deferred, particularly with regard to fine particle standards, pending establishment and operation of a national monitoring network to characterize fine PM and a research program to reduce uncertainties in the effects information. These commenters expressed concerns that establishing fine PM standards now might result in needless regulation of PM components that may be unrelated to observed health effects. As discussed more fully in Unit II.F. of this preamble, such commenters recommended, at most, that if fine PM standards were established, they should be set at a level "equivalent" to the current PM standards.

EPA strongly disagrees that the decision on revising the standards should be delayed to await the results of new PM monitoring and

research programs. Under section 109(d) of the Act, EPA's obligation after reviewing the existing criteria and standards for PM is to make such revisions in the standards and to promulgate such new standards as are appropriate under section 109(b) of the Act. Based on her review of the criteria and standards for PM, the Administrator has concluded that the current standards are not adequate to protect public health and that revisions are appropriate. In the face of the available evidence, a delay in revising the standards would not only be inconsistent with the statute but -- even under the optimistic assumption that the same extensive monitoring and strategy assessment as now contemplated would occur in the absence of a revised standard -- would add approximately 2 years to the time when significant health benefits can be realized, resulting in potentially significant numbers of additional premature deaths and even larger numbers of children and individuals with air pollution-related illness and symptoms. On the other hand, establishing standards now will set into motion the development of implementation programs and monitoring that can be conducted in parallel with additional scientific research, without undue delays inherent in waiting for the research.

The question of which pollutant components to regulate has been an issue since the inception of the first PM standards. Other ambient pollutants (e.g., NO₂ or CO) are uniquely defined as individual chemicals, whether or not they serve as proxies for a larger class of substances (e.g., ozone as an index of photochemical oxidants). Regulating general PM, as opposed to multiple chemical components of PM, raises the spectre of a host of particulate materials of varying composition, size, and other physicochemical properties, not all of which are likely to produce identical effects.

Both EPA's past and present regulatory experience with PM control programs and its successive reviews of the standards have reaffirmed the wisdom of retaining standards that control particles as a group, rather than eliminating such standards and waiting for scientific research to develop information needed to identify more precise limits for the literally thousands of particle components. Each such decision recognized the possibility that potentially less harmful particles might be included in the mix that was regulated, but concluded that the need to provide protection against serious health effects nonetheless required action under section 109 of the Act. The success of this approach is evident in early U.S. control programs that dramatically reduced "smoke" and "TSP" in major cities in the 1960's and 1970's and in the continued improvement in air quality through the current PM standards. The major refinements that have been recommended through the course of reviews of PM standards have been to improve the focus of control efforts by defining scientifically based size classes (i.e.,

moving from TSP to PM₁₀ and now, PM_{2.5}) that will permit more effective and efficient regulation of those fractions most likely to present significant risks to health and the environment.

As discussed in Unit II.C. of this preamble, the current review has examined the available evidence to determine whether it would tend to support inclusion or exclusion of any physical or chemical classes of PM, for example sulfates, nitrates, or ultra-fine particles. That examination concludes that, while both fine and coarse particles can produce health effects, the fine fraction appears to contain more of the reactive substances potentially linked to the kinds of effects observed in the recent epidemiological studies (U.S. EPA 1996b, section V.F.). However, the available scientific information does not rule out any one of these components as contributing to fine particle effects. Indeed, it is reasonable to anticipate that no single component will prove to be responsible for all of the effects of PM.

EPA recognizes that whether the standards are set for PM₁₀ only or also for fine particles, there are uncertainties with respect to the relative risk presented by various components of PM. In this regard, the Administrator places greater weight on the concern that by failing to act now, the PM NAAQS would not control adequately those components of air pollution that are most responsible for serious effects, than on the possibility they might also control some component that is not. EPA believes that moving simultaneously to establish standards based on the best available scientific evidence and to conduct an aggressive monitoring and scientific research program designed to help resolve current uncertainties is a prudent and responsible approach for addressing both the risks and the uncertainties inherent in this important public health issue.

In summary, given the evidence that PM-related health effects appear likely to occur at levels below the current standards, the serious nature and potential magnitude of the public health risks involved, and the need to consider the fine and coarse fractions as distinct classes of particles, the Staff Paper and the CASAC (Wolff, 1996b) concluded that revision of the current standards is clearly appropriate. Moreover, at their May 1996 public meeting (U.S. EPA, 1996c), and in separate written comments (including Lippmann et al., 1996), a majority of CASAC panel members recommended revisions that would strengthen the health protection provided by the current PM standards. Based on the rationale and recommendations contained in the Staff Paper and the advice of CASAC, and taking into account public comments, the Administrator concludes that it is appropriate at this time to revise the current PM standards to increase the public health protection provided against the known and potential effects of PM identified in the air quality criteria.

C. Indicators of PM

In establishing adequately protective, effective, and efficient PM standards, it is necessary to specify the fraction of particles found in the ambient air that should be used as the indicator(s) for the standards. In this regard, EPA concludes that the most recent assessment of scientific information in the Criteria Document, summarized in chapters IV and V of the Staff Paper, continues to support past staff and CASAC recommendations regarding the selection of size-specific indicators for PM standards. More specifically, EPA continues to find that the following conclusions reached in the Staff Paper and in the 1987 review remain valid:

(1) Health risks posed by inhaled particles are influenced both by the penetration and deposition of particles in the various regions of the respiratory tract and by the biological responses to these deposited materials.

(2) The risks of adverse health effects associated with deposition of ambient fine and coarse fraction particles in the thoracic (tracheobronchial and alveolar) regions of the respiratory tract are markedly greater than for deposition in the extrathoracic (head) region. Maximum particle penetration to the thoracic region occurs during oronasal or mouth breathing.

(3) The risks of adverse health effects from extrathoracic deposition of general ambient PM are sufficiently low that particles which deposit only in that region can safely be excluded from the standard indicator.

(4) The size-specific indicator(s) should represent those particles capable of penetrating to the thoracic region, including both the tracheobronchial and alveolar regions.

These conclusions, together with information on the dosimetry of particles in humans, were the basis for the promulgation in 1987 of a new size-specific indicator for the PM NAAQS, PM₁₀, that includes particles with an aerodynamic diameter smaller than or equal to a nominal 10 μm. The recent information on human particle dosimetry contained in the Criteria Document provides no basis for changing 10 μm as the appropriate cut point for particles capable of penetrating to the thoracic regions.

As noted in Unit II.B. of this preamble, however, the Staff Paper concludes that continued use of PM₁₀ as the sole indicator for the PM standards would not provide the most effective and efficient protection from the health effects of PM (U.S. EPA, 1996b, pp. VII-4 to VII-11). Based on the recent health effects evidence and the fundamental physical and chemical differences between fine and coarse fraction particles, the Criteria Document and Staff Paper conclude that fine and coarse fractions of PM₁₀ should be considered separately (U.S. EPA, 1996a, p. 13-93; 1996b, p. VII-18). Taking into account such information, CASAC found sufficient scientific and technical bases to support

establishment of separate standards relating to these two fractions of PM₁₀. Specifically, CASAC advised the Administrator that "there is a consensus that retaining an annual PM₁₀ NAAQS * * * is reasonable at this time" and that there is "also a consensus that a new PM_{2.5} NAAQS be established" (Wolff, 1996b).

Some commenters have noted that it is often difficult to distinguish the effects of either fine or coarse fraction particles from those of PM₁₀; this is to be expected because both fractions are themselves components of PM₁₀, and hence not fully independent. EPA believes that it is more meaningful to examine comparisons between the fine and coarse fraction components. Such comparisons presented in the Staff Paper suggest that fine particles are a better surrogate for those components of PM that are linked to mortality and morbidity effects at levels below the current standards (U.S. EPA, 1996b, p. VII-18). Moreover, a regulatory focus on fine particles would likely also result in controls on gaseous precursors of fine particles (e.g., SO_x, NO_x, VOC), which are all components of the complex mixture of air pollution that has most generally been associated with mortality and morbidity effects. The Staff Paper concludes that, in contrast to fine particles, coarse fraction particles are more clearly linked with certain morbidity effects at levels above those allowed by the current 24-hour standard.

Public comments received on the proposed indicators were overwhelmingly in favor of EPA's proposal to maintain PM₁₀ as an indicator for PM, whether as an indicator of coarse particles in conjunction with a fine PM standard, or as the sole PM indicator. This near unanimity shows strong support for retaining general PM standards. While a substantial number of commenters supported EPA's proposal to add an indicator for fine PM, a number of other commenters objected to any standard revisions, including addition of a fine PM indicator. Beyond the general points about the basis for any revisions discussed in Unit II.B. of this preamble, these commenters argued either that the available epidemiological data did not provide a basis for separating fine and coarse fraction particles, or that there were not enough fine particle studies to support selecting standard levels. Most of these commenters also expressed concerns that there were insufficient ambient fine particle data by which to evaluate the relative protection afforded by new standards.

EPA notes that issues relating to the basis for separating PM₁₀ fractions were addressed in the Criteria Document and/or Staff Paper assessments, and these perspectives were also available for CASAC consideration in developing its recommendations. The proposal states that the main basis for separating the fine and coarse fractions of PM₁₀ is that, because they are fundamentally different PM components with significantly

different physico-chemical properties and origins (U.S. EPA 1996b, section V.D), separate standards would permit more effective and efficient regulation of PM. While the difficulty in separating these classes in the epidemiological studies is noted above, the preponderance of the available evidence suggests that strategies to control fine particles will more effectively reduce population exposure to substances associated with health effects in the recent epidemiological studies. Although the number of studies using fine PM indicators is more limited than for PM₁₀, there are more than 20 community studies showing significant associations for a consistent set of mortality and morbidity effects. A substantial subset of these studies (Tables V-12 to V-13; U.S. EPA, 1996b) provides a sufficient quantitative basis for selecting standard levels, without the need to rely on estimates based on PM_{2.5}/PM₁₀ ratios.

Having considered the public comments on this issue, the Administrator concurs with staff and CASAC recommendations to control particles of health concern (i.e., PM₁₀) through separate standards for fine and coarse fraction particles. The following units outline the basis for the Administrator's decision on specific indicators for fine and coarse fraction particle standards.

1. *Indicators for the fine fraction of PM₁₀.* The Administrator continues to conclude that it is appropriate to control fine particles as a group, as opposed to singling out particular components or classes of fine particles. The more qualitative scientific literature, evaluated in Chapter 11 of the Criteria Document and summarized in section V.C of the Staff Paper, has reported various health effects associated with high concentrations of a number of fine particle components (e.g., sulfates, nitrates, organics, transition metals), alone or in some cases in combination with gases. Community epidemiological studies have found significant associations between fine particles or PM₁₀ and health effects in various areas across the U.S. where such fine particle components correlate significantly with particle mass. As noted above in this unit, it is not possible to rule out any one of these components as contributing to fine particle effects.²⁶ Thus, the Administrator finds that the present data more readily support a standard based on the total mass of fine particles. EPA will conduct additional research, in cooperation with other Federal

²⁶ As discussed above, a number of commenters expressed concerns that various portions of fine particles might not be responsible for any observed effects. One group (PG&E, 1997) recommended that nitrates should be excluded from fine PM mass collected on the basis of their assessment of available effects literature on particulate and gas phase inorganic nitrates. Based on an examination of this information as well as the earlier staff assessment, EPA maintains its conclusion that the available evidence is not sufficient to exclude nitrates or any other class of fine particles that are collected by PM monitors comparable to those used in the recent epidemiological studies.

agencies and in partnership with State and local agencies and the private sector, to better identify which species are of concern for human health, and the sources and relative magnitude of such species.

In specifying a precise size range for a fine particle standard, both the staff and CASAC recommended PM_{2.5} as the indicator of fine particles (Wolff, 1996b). The particle diameter reflecting the mass minimum between the fine and coarse modes typically lies between 1 and 3 μm, and the scientific data support a sampling "cut point" to delineate fine particles somewhere in this range. Because of the potential overlap of fine and coarse particle mass in this intermodal region, EPA recognizes that any specific sampling cut point would result in only an approximation of the actual fine-mode particle mass. Thus, the choice of a specific diameter within this size range is largely a policy judgment. The staff and CASAC recommendations for a 2.5 μm sampling cut point were based on considerations of consistency with the community health studies, the limited potential for intrusion of coarse fraction particles into the fine fraction, and availability of monitoring technology.²⁷ PM_{2.5} encompasses all of the potential agents of concern in the fine fraction, including most sulfates, acids, fine particle transition metals, organics, and ultrafine particles, and includes most of the aggregate surface area and particle number in the entire distribution of atmospheric particles.

The Administrator concurs with the staff and CASAC recommendations and concludes that PM_{2.5} is the appropriate indicator for fine particle standards. As discussed in Unit VI.B. of this preamble, technical details of how PM_{2.5} is to be measured in the ambient air are specified in the Federal Reference Method (40 CFR part 50, Appendix L).

2. *Indicators for the coarse fraction of PM₁₀.* The Criteria Document and Staff Paper conclude that epidemiological information, together with dosimetry and toxicological information, support the need for a particle indicator that addresses the health effects associated with coarse fraction particles within PM₁₀ (i.e., PM_{10-2.5}). As noted above,

²⁷ The National Mining Association (NMA) and related companies submitted comments favoring ultimate selection of a smaller cutpoint of 1 μm (PM₁) to further reduce coarse particle intrusion. EPA considered this approach in developing the Staff Paper and proposal. PM₁ has not been used in health studies, although in most cases collected mass should be similar to those for cutpoints of 2.1 or 2.5 μm. While a PM₁ indicator could reduce intrusion of coarse particles, it might also omit portions of hygroscopic PM components such as acid sulfates, nitrates, and some organic compounds in higher humidity environments picked up by PM_{2.5} measurements. PM₁ sampling technologies have been developed, but have not been widely used in the field to date; there are some concerns about loss of certain organic materials in available models relative to an instrument with a larger size cut. NMA has also recommended consideration of a methodology that could subtract coarse mass from PM_{2.5} measurements where undue coarse particle intrusion resulted in fine standard violations. EPA will evaluate this recommendation in the context of implementation policies.

coarse fraction particles can deposit in those sensitive regions of the lung of most concern. Although the role of coarse fraction particles in much of the recent epidemiological results is unclear, limited evidence from studies where coarse fraction particles are the dominant fraction of PM₁₀ suggest that significant short-term effects related to coarse fraction particles include aggravation of asthma and increased upper respiratory illness. In addition, qualitative evidence suggests that potential chronic effects may be associated with long-term exposure to high concentrations of coarse fraction particles.

In selecting an indicator for coarse fraction particles, the Administrator took into account the views of several CASAC panel members who suggested using the coarse fraction directly (i.e., PM_{10-2.5}) as the indicator. However, the Administrator notes that the existing ambient data base for coarse fraction particles is smaller than that for fine particles, and that the only studies of clear quantitative relevance to effects most likely associated with coarse fraction particles have used undifferentiated PM₁₀. In fact, it was the consensus of CASAC that it is reasonable to consider PM₁₀ itself as a surrogate for coarse fraction particles, when used together with PM_{2.5} standards. The monitoring network already in place for PM₁₀ is large. Therefore, in conjunction with the decision to have separate standards for PM_{2.5}, the Administrator concludes, consistent with CASAC recommendations and public comments, that it is appropriate to retain PM₁₀ as the indicator for PM standards intended to protect against the effects most likely associated with coarse fraction particles.

D. Averaging Time of PM_{2.5} Standards

As discussed above in this unit, the Administrator has concluded that PM_{2.5} is an appropriate indicator for standards intended to provide protection from effects associated primarily with fine particles. The recent health effects information includes reported associations with both short-term (from less than 1 day to up to 5 days) and long-term (from a year to several years) measures of PM.

On the basis of this information, summarized in chapter V of the Staff Paper and in the rationale presented in the proposal, the Administrator has considered both short- and long-term PM_{2.5} standards.

1. *Short-term PM_{2.5} standard.* The current 24-hour averaging time is consistent with the majority of community epidemiological studies, which have reported associations of health effects with 24-hour concentrations of various PM indicators such as PM₁₀, fine particles, and TSP. Such health effects, including premature mortality and increased hospital admissions, have generally been reported with same-day, previous day, or longer lagged single-day concentrations, although some studies have reported stronger

associations with multiple-day average concentrations. In any case, the Administrator recognizes that a 24-hour PM_{2.5} standard can effectively protect against episodes lasting several days, since attainment of such a standard would provide protection on each day of a multi-day episode, while also protecting sensitive individuals who may experience effects after even a single day of exposure.

Although most reported effects have been associated with daily or longer measures of PM, evidence also suggests that some effects may be associated with PM exposures of shorter durations. For example, controlled human and animal exposures to specific components of fine particles, such as acid aerosols, suggest that bronchoconstriction can occur after exposures of minutes to hours. Some epidemiological studies of exposures to acid aerosols have also found changes in respiratory symptoms in children using averaging times less than 24 hours. However, such reported results do not provide a satisfactory quantitative basis for setting a fine particle standard with an averaging time of less than 24 hours, nor do current gravimetric mass monitoring devices make such shorter durations generally practical at present. Further, the Administrator recognizes that a 24-hour average PM_{2.5} standard which leads to reductions in 24-hour average concentrations is likely to lead as well to reductions in shorter-term average concentrations in most urban atmospheres, thus providing some degree of protection from potential effects associated with shorter duration exposures.

2. *Long-term PM_{2.5} standard.* Community epidemiological studies have reported associations of annual and multi-year average concentrations of PM₁₀, PM_{2.5}, sulfates, and TSP with an array of health effects, notably premature mortality, increased respiratory symptoms and illness (e.g., bronchitis and cough in children), and reduced lung function. The relative risks associated with such measures of long-term exposures, although highly uncertain, appear to be larger than those associated with short-term exposures. Based on the available epidemiology, and consistent with the limited relevant toxicological and dosimetric information, the Administrator concludes that significant, and potentially independent, health consequences are likely associated with long-term PM exposures.

The Administrator has considered this evidence, which suggests that some health endpoints reflect the cumulative effects of PM exposures over a number of years. In such cases, an annual standard would provide effective protection against persistent long-term (several years) exposures to PM. Requiring a much longer averaging time would also complicate and unnecessarily delay control strategies and attainment decisions.

The Administrator has also considered the seasonality of emissions of fine particles and their precursors in some areas (e.g., wintertime smoke from residential wood combustion, summertime regional acid sulfate and ozone formation), which suggests that some effects associated with annual average concentrations might be the result of repeated seasonally high exposures. However, different seasons are likely of concern in different parts of the country, and the current evidence does not provide a satisfactory quantitative basis for setting a national fine particle standard in terms of a seasonal averaging time.

In addition, the Administrator recognizes that an annual standard would have the effect of improving air quality broadly across the entire annual distribution of 24-hour PM_{2.5} concentrations, although such a standard would not as effectively limit peak 24-hour concentrations as would a 24-hour standard. The risk assessment summarized above found that because such 24-hour peaks contribute much less to the total health risk over a year than the more numerous low- to mid-range PM_{2.5} levels, an annual standard could also provide effective protection from health effects associated with short-term exposures to PM_{2.5} as well as those associated with long-term exposures (see figure 2; 61 FR 65652-65653, December 13, 1996).

3. *Combined effect of annual and 24-hour standards.* For the reasons outlined in Units II.C.1. and 2. of this preamble, the Administrator concluded in the proposal that a short-term PM_{2.5} standard with a 24-hour averaging time can serve to control short-term ambient PM_{2.5} concentrations, thus providing protection from health effects associated with short-term (from less than 1-day to up to 5-day) exposures to PM_{2.5}. Further, a long-term PM_{2.5} standard with an annual averaging time can serve to control both long- and short-term ambient PM_{2.5} concentrations, thus providing protection from health effects associated with long-term (seasonal to several years) and, to some degree, short-term exposures to PM_{2.5}.

EPA received comparatively few public comments on these proposed averaging times. Those supporting PM_{2.5} standards also strongly supported adopting both annual and 24-hour averaging times. Many of those opposing PM_{2.5} standards, for the reasons discussed in Unit II.B. of this preamble, provided contingent comments that variously supported both averaging times for PM_{2.5} standards in the event the Administrator disagreed with their overall recommendations. Other opponents of PM_{2.5} standards disagreed with having two standards on administrative grounds, or because some CASAC members did not support both averaging times.

The relationship between standards for the two averaging times is discussed below in this unit. In essence, based on its examination of the effects data and air quality relationships, EPA believes that a single PM_{2.5} standard (24-hour or annual) either

would not provide adequate protection against effects of concern for all averaging times, or would be inefficient in the sense that it was more stringent than necessary for at least one averaging time. Contrary to commenters who focused on minority CASAC opinions, EPA notes that a clear majority of CASAC supported both 24-hour and annual standards²⁸. After considering public comments on averaging time and the rationale outlined above, the Administrator has concluded that both 24-hour and annual PM_{2.5} standards are appropriate.

The Administrator next considered the potential combined effects of such standards on PM concentration levels and distributions. The existing health effects evidence could, of course, be used to assess the form and level of each standard independently, with short-term exposure health effects evidence being used as the basis for a 24-hour standard and the long-term exposure health effects evidence as the entire basis for an annual standard. Some CASAC panel members apparently used this approach as a basis for their views on appropriate averaging times and standard levels. In particular, a few members focused only on a 24-hour PM_{2.5} standard in light of the relative strength of the short-term exposure studies. On the other hand, two members focused only on an annual standard, recognizing that strategies to meet an annual standard would provide protection against effects of both short- and long-term exposures.

As noted above in this unit, attempting to provide protection for all of the effects identified in long- and short-term PM exposure studies with a single averaging time would result in either inadequate protection for some effects, or unnecessarily stringent control for others. The Administrator has, instead, emphasized a policy approach that considers the consistency and coherence, as well as the limitations, of the body of evidence as a whole, and recognizes that there are various ways to combine two standards to achieve an appropriate degree of public health protection. Such an approach to standard setting, which integrates the body of health effects evidence and air quality analyses, and considers the combined effect of the standards, has the potential to result in a more effective and efficient suite of standards than an approach that only considers short- and long-term exposure evidence, analyses, and standards independently.

In considering the combined effect of such standards, the Administrator notes that while an annual standard would focus control programs on annual average PM_{2.5} concentrations, it would also result in fewer and lower 24-hour peak concentrations.

²⁸ Of the 19 panel members who joined in the consensus for PM_{2.5} standards, 17 (90 percent) recommended a 24-hour standard and 13 (70 percent) recommended an annual standard (Wolff, 1996b).

Alternatively, a 24-hour standard that focuses controls on peak concentrations could also result in lower annual average concentrations. Thus, either standard could be viewed as providing both short- and long-term protection, with the other standard serving to address situations where the daily peaks and annual averages are not consistently correlated.

The Administrator proposed that the suite of PM_{2.5} standards could most effectively and efficiently be defined by treating the annual standard as the generally controlling standard for lowering both short- and long-term PM_{2.5} concentrations. In conjunction with the annual standard, the 24-hour standard would serve to provide protection against days with high peak PM_{2.5} concentrations, localized "hot spots," and risks arising from seasonal emissions that would not be well controlled by a national annual standard.

Relatively few public comments were addressed specifically to the proposal that the annual standard be directed toward controlling both 24-hour and annual levels (thereby basing the annual standard on an evaluation of both the short- and long-term health effects information), with the 24-hour standard being used to address more localized short-term peaks. A number of commenters, notably some among the groups opposing any revised PM standards, appeared to have ignored this fundamental aspect of the proposal, judging by their assertions that the sole basis for EPA's proposed annual standards was two long-term exposure studies (Dockery et al., 1993; Pope et al. 1995). This is incorrect; as the proposal states, EPA based the proposed annual standard level on a wider range of short- and long-term exposure studies. Other commenters, including some environmental groups, reserved comment on this specific issue, but expressed concerns that the specific levels for both standards were not stringent enough, regardless of which standard is intended to be controlling. Issues regarding specific levels are discussed below in Unit II.F. of this preamble.

Some commenters, however, disagreed with the proposition that EPA's proposed approach would necessarily provide the most effective and efficient standards. In the view of some who opposed PM_{2.5} standards, the likelihood that there are thresholds below which no effects occur means that a 24-hour standard would be more efficient than an annual standard. In this view, the reductions made on days that were below the threshold would provide no protection.²⁹ Some

²⁹ A related comment criticized the risk assessment conclusion that peak 24-hour concentrations contribute much less to the total risk over a year as inconsistent with the experience in historic air pollution episodes. EPA disagrees. While the historic London episodes were quantitatively different from those assumed in the risk assessment, the record over 14 London winters indicates a continuum of effects down to the lowest levels. It is therefore likely that the cumulative increase in mortality calculated for all the days in the whole 14-year period

commenters also noted that while a majority of CASAC members favored both annual and 24-hour standards, more recommended 24-hour standards.

While the available epidemiological studies provide strong evidence suggesting that PM causes or contributes to health effects at levels below the current standards, EPA agrees, as stated previously, that uncertainties increase markedly at lower concentrations. Nevertheless, the level or even existence of population thresholds below which no effects occur cannot be reliably determined by an examination of the results from the available studies. Analyses have placed some limits, however, and EPA has considered hypothetical thresholds in its risk assessment. As noted in Unit II.A. of this preamble, even assuming an example threshold of $18 \mu\text{g}/\text{m}^3$, the risk assessment (see Figure 2c; 61 FR 65653, December 13, 1996) finds that most of the annual aggregate risk associated with short-term exposures still results from the large number of days at lower to mid-range values above the mean. Given that neither the Criteria Document nor commenters have provided quantitative evidence regarding the likelihood of a threshold at levels much higher than the above example, EPA believes that the evidence provided in the risk assessment does not support the commenters' position. As noted above, EPA believes that most CASAC opinions on averaging time reflect panelists' judgments on the relative strength of the short-term exposure epidemiological studies, a judgment that EPA shares. Although most CASAC panel members did not offer an opinion on the use of short-term exposure studies in specifying annual standards, two panelists did support this notion. EPA therefore believes this approach is neither inconsistent with the underlying science nor discordant with the advice of CASAC.

Another concern was raised by some air pollution control officials who otherwise supported revised PM standards. These commenters state that, from an implementation perspective, it is often easier to design control strategies for single short-term events than for annual averages. Aside from whether this is a proper consideration in establishing NAAQS, the point in fact highlights one of the important strengths of an annual standard in addressing short-term risks associated with $\text{PM}_{2.5}$. As noted by the commenters, risk management for a short-term standard focuses on a characteristic "design value" episode responsible for peak concentrations. For PM, such peak values can be associated with single source contributions. Meteorology, relative source contributions, and resulting particle composition for that day may or may not be typical for the area or for the year. Yet the short-term exposure epidemiological results

would not be dominated by the more limited number of episode days.

are largely drawn from studies that associated variations in area-wide effects with monitor(s) that gauged the variation in daily levels over the course of up to 8 years. The strength of the associations in these data is demonstrably in the numerous "typical" days in the upper to middle portion of the annual distribution, not on the peak days.³⁰ For these reasons, strategies that focus only on reducing peak days are less likely to achieve reduction of the mix and sources of urban and regional-scale PM pollution most strongly associated with health effects. Although designing control strategies to reduce annual levels may be more difficult than for 24-hour standards, the available short- and long-term epidemiological data suggest it is also likely to result in a greater reduction in area-wide population exposure and risk.

The Administrator concludes that the most effective and efficient approach to establishing $\text{PM}_{2.5}$ standards is to treat the annual standard as the generally controlling standard for lowering both short- and long-term $\text{PM}_{2.5}$ concentrations, while the 24-hour standard would serve to provide protection against days with high peak $\text{PM}_{2.5}$ concentrations, localized "hot spots," and risks arising from seasonal emissions that would not be well controlled by a national annual standard. In reaching this view, the Administrator took into account the public comments and the factors discussed below in this unit.

(1) Based on one of the key observations from the quantitative risk assessment summarized above (see Figures 2a,b,c; 61 FR 65652-65653, December 13, 1996), the Administrator notes that much if not most of the aggregate annual risk associated with short-term exposures results from the large number of days during which the 24-hour average concentrations are in the low- to mid-range, below the peak 24-hour concentrations. As a result, lowering a wide range of ambient 24-hour $\text{PM}_{2.5}$ concentrations, as opposed to focusing on control of peak 24-hour concentrations, is the most effective and efficient way to reduce total population risk. Further, there is no evidence suggesting that risks associated with long-term exposures are likely to be disproportionately driven by peak 24-hour concentrations. Thus, an annual standard that controls an area's attainment status is likely to reduce aggregate risks associated with both short- and long-term exposures with more certainty than a 24-hour standard.

(2) The consistency and coherence of the health effects data base are, therefore, more directly related to the more frequently occurring PM exposures reflected in study period mean measures of air quality (e.g., the annual distributions of 24-hour PM

³⁰ This point is buttressed by studies that have taken out a limited number of higher PM concentration days with little effect on the effects estimates or significance of the association (e.g., Schwartz et al., 1996; Pope and Dockery, 1992).

concentrations), than to the potentially site-specific and/or otherwise infrequent PM exposures reflected in a limited number of peak 24-hour concentrations. More specifically, judgments about the quantitative consistency of the large number of short-term exposure studies reporting associations with 24-hour concentrations arise from comparing the relative risk results per PM increment as derived from analyzing the associations across the entire duration of the studies. These studies typically spanned at least an annual time frame and the reported associations are most strongly influenced by the large number of days toward the middle of the distribution.

(3) An annual average measure of air quality is more stable over time than are 24-hour measures. Thus, a controlling annual standard is likely to result in the development of more consistent risk reduction strategies over time, since an area's attainment status will be less likely to change due solely to year-to-year variations in meteorological conditions that affect the formation of fine particles, than under a controlling 24-hour standard.

Under this policy approach, the annual $\text{PM}_{2.5}$ standard would serve in most areas as the target for control programs designed to be effective in lowering the broad distribution of $\text{PM}_{2.5}$ concentrations, thus protecting not only against long-term effects but also short-term effects as well. In combination with such an annual standard, the 24-hour $\text{PM}_{2.5}$ standard would be set so as to protect against the occurrence of peak 24-hour concentrations, particularly peak concentrations that present localized or seasonal exposures of concern in areas where the highest 24-hour-to-annual mean $\text{PM}_{2.5}$ ratios are appreciably above the national average.

E. Form of $\text{PM}_{2.5}$ Standards

1. *Annual standard.* As discussed in some detail during the last review of the PM NAAQS (see 49 FR 10408, March 20, 1984; 52 FR 24634, July 1, 1987) and in the December 13, 1996 proposal, the annual arithmetic mean form of the current annual PM_{10} standard (i.e., the annual arithmetic mean averaged over 3 years) is a relatively stable measure of air quality that reflects the total cumulative dose of PM to which an individual or population is exposed. Short-term peaks have an influence on the arithmetic mean that is proportional to their frequency, magnitude, and duration, and, thus, their contribution to cumulative exposure and risk. As a result, the annual arithmetic mean form of an annual standard provides protection across a wide range of the air quality distribution contributing to exposure and risk, in contrast to other forms, such as the geometric mean, that de-emphasize the effects of short-term peak concentrations.

While almost no commenters took specific issue with use of an annual arithmetic mean,

a number of commenters disagreed with averaging over 3 years for both the annual and 24-hour standards because of their desire for quick action in the initial implementation of PM_{2.5} controls. The Administrator recognizes the importance of promptly implementing appropriate control programs, but she does not believe that implementation start-up concerns are an adequate basis for adopting a form (e.g., a single year annual average) that would provide less stable risk reduction in the long-run. Therefore, the Administrator continues to concur with the Staff Paper recommendation, supported by CASAC, to use the annual arithmetic mean, averaged over 3 years, as the form for an annual PM_{2.5} standard consistent with the current form of the annual PM₁₀ standard. Nevertheless, EPA intends to address the concerns of those who commented that the 3-year form might prevent the public from being informed about the air quality status of their communities. As outlined in Unit II.H. of this preamble, EPA plans to issue revised Pollutant Standard Index criteria for PM_{2.5}, to ensure the public is informed promptly about air quality status.

The Staff Paper and some CASAC panel members also recommended that consideration be given to calculating the PM_{2.5} annual arithmetic mean for an area by averaging the annual arithmetic means derived from multiple monitoring sites within a monitoring planning area. In proposing a calculation method for annual arithmetic averages that involves spatial averaging of monitoring data, the Administrator reasoned as follows:

(1) Many of the community-based epidemiological studies examined in this review used spatial averages, when multiple monitoring sites were available, to characterize area-wide PM exposure levels and the associated population health risk. In those studies that used only one monitoring location, the selected site was chosen to represent community-wide exposures, not the highest value likely to be experienced within the community. Thus, spatial averages are most directly related to the epidemiological studies used as the basis for the proposed revisions to the PM NAAQS.

(2) As a part of the overall policy approach discussed in Unit II.D. of this preamble, the annual PM_{2.5} standard would be intended to reduce aggregate population risk from both long- and short-term exposures by lowering the broad distribution of PM_{2.5} concentrations across the community. An annual standard based on spatially averaged concentrations would better reflect area-wide PM exposure levels than would a standard based on concentrations from a single monitor with the highest measured values.

(3) Under this policy approach, the 24-hour PM_{2.5} standard would be intended to work in conjunction with a spatially averaged annual PM_{2.5} standard by providing protection against peak 24-hour concentrations, localized

“hot spots,” and higher PM_{2.5} concentrations arising from seasonal emissions and meteorology that would not be as well controlled by an annual standard. Accordingly, the 24-hour PM_{2.5} standard should be based on the single population-oriented monitoring site within the monitoring planning area with the highest measured values.

Based on these considerations, the Administrator proposed that the form of an annual PM_{2.5} standard be expressed as the annual arithmetic mean, temporally averaged over 3 years and spatially averaged over all designated monitoring sites,³¹ which, in conjunction with a 24-hour PM_{2.5} standard, was intended to provide the most appropriate target for reducing area-wide population exposure to fine particle pollution. Recognizing the complexities that spatial averaging might introduce into risk management programs, in the proposal the Administrator also requested comment on the alternative of basing the annual standard for PM_{2.5} solely on the single population-oriented monitor site within the monitoring planning area with the highest 3-year average annual mean.

The proposed approach to designating sites that are appropriate for spatial averaging was based on criteria and constraints contained in the proposed revision to the monitoring siting and network planning requirements in 40 CFR part 58. In proposing this approach, the Administrator noted concerns regarding the development and implementation of appropriate and effective criteria for the selection of sites and designations of areas for spatial averaging.

A number of commenters who otherwise favored setting PM_{2.5} standards objected to the concept of population-oriented monitors and expressed the view that any monitor regardless of where it was sited should be eligible for comparison to the annual PM_{2.5} standard. They further maintained that the proposed provisions for spatial averaging would fail to provide adequate health protection because “clean areas” and “dirty areas” would be averaged together. Some commenters expressed concern that the proposed constraints on spatial average would not be sufficient to prevent use of such averaging to avoid pollution abatement. Others may not have fully understood the implications of the specific constraints and siting requirements discussed in the proposed revisions to 40 CFR part 58, which were intended to ensure that the population-oriented monitors used for the annual standard were actually reflective of community-wide exposures and that the spatial averages did not include non-representative monitored values from either

³¹ The notice of proposed revisions to 40 CFR part 58 recognized that a single appropriately sited monitor could suffice for an area in place of an average of multiple monitors.

“clean areas” or “dirty areas.”³² In order to clarify the intent that the spatially averaged annual standard protect those in smaller communities, as well as those in larger population centers, the final revisions to 40 CFR part 58 adopt the term “community-oriented” monitors.

Other commenters, who supported PM_{2.5} annual standards, endorsed the concept of spatial averaging as being more reflective of the air quality data used in the underlying health studies and because there is general uniformity of fine particle concentrations across an area. Opponents of the PM_{2.5} standards expressed contingent support for spatial averaging in concept, again citing the linkage to the underlying health studies. Indeed, they advocated the extension of spatial averaging to the daily form of the standard, and/or recommended less constrained spatial averaging to allow for averaging across entire metropolitan areas.

The Administrator, of course, shares commenters’ concerns that the form of the standards, in conjunction with other components of the standards, must protect public health adequately against risks associated with PM. It was for this reason that EPA proposed a policy approach providing for greatest overall risk reduction for all citizens in the community from exposures to the mix of urban and regional scale PM pollution most strongly associated with health effects. In specifically considering whether to allow for the use of spatial averaging, the Administrator placed great weight on consistency with the underlying body of health effects evidence. The Administrator is mindful that some community studies relied inherently on exposure and effects estimates that reflect comparatively broad spatial scales, as highlighted by those commenters desiring to extend permissible averaging; however, this type of exposure characterization may not be appropriate for all circumstances and might leave some areas without adequate protection.³³

³² The 40 CFR part 58 proposed rule identified the proposed criteria for monitors to be averaged; namely, monitors must be properly sited to reflect population-orientation, primarily influenced by similar sources, and within +/-20 percent of the average levels and a specific degree of correlation (or meet a “homogeneity” constraint). Additional criteria include demonstrations that the monitors to be averaged are influenced primarily by similar sources (e.g., to prevent the placement of monitors upwind in unrepresentative locations), EPA oversight of the monitoring program which includes regular review and approval of the State PM monitoring network design, and other criteria to ensure proper monitor siting. The final rule includes the addition of provisions that the State PM monitoring network design be available for public inspection.

³³ Daily mortality studies generally use urban or metro-areawide effects statistics in conjunction with single or multiple monitors that index day-to-day pollution changes across the area. Ito et al. (1995) found that spatial averages from multiple PM monitors in Chicago were better correlated with daily mortality than were most single monitors, but that single monitors were also associated. A number of morbidity studies (e.g., Schwartz et al., 1994;

For these reasons, the 40 CFR part 58 proposal package contained criteria and constraints on spatial averaging. These criteria and constraints were intended to ensure that spatial averaging would not result in inequities in the level of protection provided by the PM standards. The Administrator again recognizes that either a single properly sited community-oriented monitor, or an average of more than one such monitors, are both appropriate indices of area-wide population exposures. Both are consistent with monitoring approaches used in community epidemiological studies upon which the standards are based. On the other hand, comparing the annual PM_{2.5} standard to the maximum concentrations at a site that is not representative of community exposures, as some have suggested, would be inconsistent with the Administrator's goal of using the annual standard to reduce urban and regional scale exposures and risks. Further, the Administrator believes that the criteria and, siting requirements contained in 40 CFR part 58, provide adequate safeguards against inappropriate application of spatial averaging. Therefore, the Administrator continues to believe that an annual PM_{2.5} standard reflective of area-wide exposures, in conjunction with a 24-hour standard designed to provide adequate protection against localized peak or seasonal PM_{2.5} levels, reflects the most appropriate approach for public health against the effects of PM reported in the scientific literature.³⁴

The majority of comments from States stressed the need for flexibility in specifying network designs and spatial averaging, given that the nature and sources of particle pollution vary from one area to another. One State agency specifically requested the flexibility to choose whether to use a single community-oriented monitor or a spatial average of several of such monitors, arguing that it is appropriate to provide this flexibility as PM_{2.5} monitoring networks evolve and to address the diversity of local conditions.

As a result of EPA's evaluation of these comments, the requirements of 40 CFR part 50, Appendix K, and 40 CFR part 58 have been revised to clarify that the implementing agencies have the flexibility to compare the annual PM_{2.5} standard either to the measured value at a single representative community-oriented monitoring site, or to the value resulting from an average of community-oriented monitoring sites that meet the revised criteria and constraints enumerated in the 40 CFR part 58 final rule.

In the Administrator's view, the final criteria and siting requirements contained in 40 CFR part 58 and in the new 40 CFR part

50, Appendix N, address the concerns raised by these commenters about the protection afforded by the form of the annual standard. Therefore, the Administrator continues to believe that the form of a PM_{2.5} annual standard should be expressed as an annual arithmetic mean, averaged over 3 years, from single or multiple community-oriented monitors, in accordance with 40 CFR part 50, Appendix N and 40 CFR part 58. In her judgment, an annual standard expressed in this manner and set at an appropriate level, in conjunction with a 24-hour PM_{2.5} standard, will adequately protect public health.

2. *24-hour standard.* The current 24-hour PM₁₀ standard is expressed in a "1-expected-exceedance" form. That is, the standard is formulated on the basis of the expected number of days per year (averaged over 3 years) on which the level of the standard will be exceeded. The test for determining attainment of the current 24-hour standard is presented in Appendix K to 40 CFR part 50.

As discussed in the proposal, since promulgation of the current 24-hour PM₁₀ standard in 1987, a number of concerns have been raised about the 1-expected-exceedance form. These include, in particular, the year-to-year stability of the number of exceedances, the stability of the attainment status of an area, and the complex data handling conventions specified in 40 CFR part 50, Appendix K, including the procedures for making adjustments for missing data and less-than-every-day monitoring.

In light of these concerns, the Staff Paper and several CASAC panel members (Wolff, 1996b) recommended that consideration be given to adoption of a more stable and robust form for 24-hour standards. In considering this recommendation for the proposal, the Administrator noted that the use of a concentration-based percentile form would have several advantages over the current 1-expected-exceedance form:

(1) Such a concentration-based form would be more directly related to the ambient PM concentrations that are associated with health effects. Given that there is a continuum of effects associated with exposures to varying levels of PM, the extent to which public health is affected by exposure to ambient PM is related to the actual magnitude of the concentration, not just whether the concentration is above a specified level. With an exceedance-based form, days on which the ambient concentration is well above the level of the standard are given equal weight to those days on which the concentration is just above the standard (i.e., each day is counted as one exceedance), even though the public health impact on the 2 days is significantly different. With a concentration-based form, days on which higher concentrations occur would weigh proportionally more than days with lower concentrations for the design value, since the actual concentrations would

be used directly in determining whether the standard is attained.

(2) A concentration-based percentile form would also compensate for missing data and less-than-every-day monitoring, thereby reducing or eliminating the need for complex data handling procedures in the 40 CFR part 50, Appendix K test for attainment. As a result, an area's attainment status would be based directly on monitoring data rather than on a calculated value adjusted for missing data or less-than-every-day monitoring.

(3) Further, a concentration-based form, averaged over 3 years, would also have greater stability than the expected exceedance form and, thus, would facilitate the development of more stable implementation programs by the States.

The proposal discussed various specific percentile values for such a form (e.g., 90th to 99th percentiles), taking into account two factors. First, the 24-hour PM_{2.5} standard is intended to supplement the annual PM_{2.5} standard by providing additional protection against extremely high peak days, localized "hot spots," and risks arising from seasonal emissions. Second, given an appropriate level of health protection, the form of the 24-hour PM_{2.5} standard should provide an appropriate degree of increased stability relative to the current form. The Administrator noted in the proposal that a more stable statistic would reduce the impact of a single high exposure event that may be due to unusual meteorological conditions alone, and thus would provide a more stable basis upon which to design effective control programs.

With these purposes in mind, the Administrator observed in the proposal that while a percentile value such as the 90th or 95th would provide substantially increased stability when compared to a more extreme air quality statistic (e.g., the current 1-expected-exceedance form), it would likely not serve as an effective supplement to the annual standard, because it would allow a large number of days with peak PM_{2.5} concentrations above the standard level. For example, in a 365-day data base, the 90th and 95th percentiles would equal the 37th and 19th highest 24-hour concentrations, respectively. On the other hand, a percentile value selected much closer to the tail of the air quality distribution (e.g. a 99th or greater percentile) would not likely provide significantly more health protection or significantly increased stability as compared to a 1-exceedance form. In balancing these issues in the proposal, the Administrator ultimately proposed a 98th percentile value form of the standard.

Some commenters maintained that EPA should retain the current 1-expected-exceedance form for the 24-hour PM_{2.5} standard to limit the number of days per year that the standard is exceeded. These commenters apparently gave little weight to EPA's rationale that a concentration-based form is more directly related to ambient PM concentrations that are associated with health

Neas et al., 1995; Raizenne et al.; 1996) used community scale monitors and effects information from a defined group of subjects from the community, who were more closely represented by the monitor.

³⁴ Because the 24-hour standard is designed to address localized peaks, it would be inappropriate to extend spatial averaging forms to this standard.

effects because it takes into account the magnitude of PM concentrations, not just whether the concentrations are above a specific level. These commenters also discounted the other advantages of a concentration-based percentile form outlined above in this unit. A number of other commenters supported the concentration-based percentile form for the reasons outlined in the proposal but, as discussed below in this unit, argued for alternative percentile values that were higher or lower than the proposed 98th percentile value.

EPA continues to believe that a concentration-based percentile form is more reflective of the health risk posed by elevated PM concentrations, because it gives proportionally greater weight to days when concentrations are well above the level of the standard than to days when the concentrations are just above the standard. This factor, coupled with the other advantages outlined above in this unit, leads EPA to conclude that a concentration-based percentile form will provide for more effective health protection than a 1-expected-exceedance form.

Some commenters supporting a single exceedance form or a more restrictive concentration-based percentile form (e.g. a 99th percentile) expressed concern that the proposed 98th percentile form could allow too many high concentration excursions, and thus fail to provide adequate protection against seasonal emissions problems or localized peaks. In particular, some commenters expressed concerns that in areas with strongly seasonal emissions, such as western areas with winter inversions, over a three year period an area could experience several excursions in which levels could reach as high as 250 $\mu\text{g}/\text{m}^3$ and still comply with both the annual and daily standards if the remainder of the days had low levels (e.g., 10 $\mu\text{g}/\text{m}^3$). Although this combination of events is theoretically possible, EPA believes it is unlikely. Moreover, if such episodic events did occur, the Act provides for emergency State or Federal action to address them.³⁵ In view of the limits on truly episodic peak concentrations, EPA believes that an appropriately selected 24-hour standard with a concentration-based 98th percentile form can provide a stable and adequately protective supplement to the annual standard in areas with periodic peak concentrations.

Other commenters who were also concerned with monitoring requirements associated with spatial averaging in the annual standard, argued that a 98th percentile

form, coupled with the proposed monitoring requirements that would limit compliance monitors for the 24-hour standard to population-oriented sites, would not protect people residing in or near localized "hot spots" in some areas.³⁶ The Administrator believes that the siting requirements as proposed and finalized in 40 CFR part 58 for population-oriented sites will provide adequate safeguards for such residential areas.

Other commenters, who otherwise opposed setting PM_{2.5} standards, recommended that alternative lower percentiles (e.g., 95th percentiles) be used, if EPA proceeds to set such standards. As discussed above in this unit, however, EPA continues to hold the view that a 90th to 95th percentile form would not provide an adequate limit against periodic peak values in areas with low annual values and periodic high seasonal or source-oriented peaks.

After carefully assessing the comments received, the Administrator is persuaded that the adoption of a 98th percentile form for the 24-hour PM_{2.5} standard measured at each population-oriented monitoring site in an area would provide an effective supplement to the annual PM_{2.5} standard. This form will provide adequate protection against 24-hour peak PM_{2.5} levels in locations dominated by single point sources, as well as in areas dominated by seasonal emissions. The Administrator also believes that a 98th percentile form, with more frequent sampling and averaged over 3 years, will provide increased stability and robustness as recommended by several members of the CASAC panel. For these reasons, the Administrator has decided to adopt the 98th percentile form for the final PM_{2.5} 24-hour standard. The 24-hour PM_{2.5} standard would be attained when the 3-year average of the 98th percentile of 24-hour concentrations at each populated oriented monitor within an area is less than or equal to the level of the standard. Further details regarding the interpretation of the form, as well as associated calculations and other data handling conventions are specified in the new 40 CFR part 50, Appendix N.

F. Levels for the Annual and 24-Hour PM_{2.5} Standards

As discussed in Unit II.D. of this preamble, the Administrator believes that an annual PM_{2.5} standard can provide the requisite reduction in risk associated with both annual and 24-hour averaging times in most areas of the United States. Under this approach, the 24-hour standard would be intended to provide supplemental protection against extreme peak fine particle levels that may occur in some localized situations or in areas with distinct variations in seasonal fine particle levels. In reaching judgments as to

appropriate levels to propose for both the annual and 24-hour PM_{2.5} standards, the Administrator has considered the combined protection afforded by both the annual and 24-hour standards, taking into account the forms discussed in Unit II.E. of this preamble.

With this approach in mind, the Administrator has considered the available health effects evidence and related air quality information presented in the Criteria Document and summarized in chapters IV--VII of the Staff Paper, which provides the basis for decisions on standard levels that would reduce risk sufficiently to protect public health with an adequate margin of safety, recognizing that such standards will not be risk-free. In so doing, the Administrator has considered both the strengths and the limitations of the available evidence and information, as well as alternative interpretations of the scientific evidence advanced by various CASAC panel members (Wolff, 1996b; Lippmann et al., 1996) and public commenters, arising primarily from the inherent uncertainties and limitations in the health effects studies.

Beyond those factors, but clearly related to them, a range of views have been expressed by CASAC panel members and the public as to the appropriate policy response to the available health effects evidence and related air quality information. Toward one end of the spectrum, the view has been expressed that only a very limited policy response is appropriate in light of the many key uncertainties and unanswered questions that, taken together, call into question the fundamental issue of causality in the reported associations between ambient levels of PM_{2.5} and mortality and other serious health effects. Toward the other end, the view has been expressed that the consistency and coherence of the epidemiological evidence should be interpreted as demonstrating causality in the relationships between PM_{2.5} and health endpoints that are clearly adverse, and that uncertainties in the underlying health effects information should be treated, regardless of their nature, as warranting a maximally precautionary policy response. A third view would suggest an alternative policy response, taking into account not only the consistency and coherence of the health effects evidence, but also the recognition of key uncertainties and unanswered questions that increasingly call into question the likelihood of PM-related effects as PM_{2.5} concentrations decrease below the mean values in areas where effects have been observed and/or as such concentrations approach background levels.

Reflecting these divergent views, both of the science itself and of how the science should be used in making policy decisions on proposed standards, the Administrator considered three alternative approaches to selecting appropriate standard levels, as described in the proposal, ultimately deciding to propose standards based on a balanced view of the strengths and uncertainties of the

³⁵ See sections 303, 110(a)(2)(y); 40 CFR part 51. EPA intends to establish a significant harm level for PM_{2.5} and associated guidance so States can develop appropriate emergency episode plans. The significant harm and episode criteria will be included in forthcoming proposed revisions to 40 CFR part 51 and 40 CFR part 58 implementation guidance. In the interim, existing PM₁₀ emergency episode plans should be triggered by events of this magnitude.

³⁶ The 40 CFR part 58 monitoring rule proposed to limit sites that would be eligible for comparisons to the 24-hour standard to population-oriented monitoring sites.

scientific information that reflects the intermediate approach.

Judging by the public comments received, EPA accurately reflected the bases for divergent views. A substantial body of public comments supported revising the PM standards by adding PM_{2.5} standards with levels at least as stringent as those proposed by the Administrator. In general, however, comments on levels for PM_{2.5} standards revealed a strong dichotomy between those who recommended even stronger standards than proposed, and those who counseled against revising the standards at all. As noted above in this unit, many in this latter group made contingent recommendations with respect to the levels and other aspects of PM_{2.5} standards, if the Administrator concluded that any revisions were appropriate.

This latter group of "contingent" commenters recommended levels well above those proposed by the Administrator. These commenters placed great weight on factors outlined in Units II.B. and II.C. of this preamble that led them to oppose any revisions to the PM standards, including the uncertainties and limitations in the available health effects studies considered individually, such as the possible existence of effects thresholds and unanswered questions regarding the causal agent(s) responsible for the reported health effects. Further, they emphasized the limited amount of research currently available that has measured PM_{2.5} directly. A substantial group recommended that PM_{2.5} standards be selected so as to be equivalent or close in stringency to the current PM₁₀ standards, and cited the opinions of some CASAC PM panel members as support. Some of these commenters provided supplemental analyses of air quality data, arguing that they demonstrate that "equivalent" standards would be at PM_{2.5} levels as high as approximately 95 µg/m³ 24-hour average and 27 µg/m³ annual average.

Having evaluated these comments, the Administrator rejects both their underlying rationale and the specific recommendations for PM_{2.5} standard levels that result in similar or only marginally more protection than that afforded by the current PM₁₀ standards. Aside from technical problems in the commenters' supporting analyses on the issue of defining "equivalent" standards,³⁷ the Administrator finds this approach inconsistent with her conclusions regarding the adequacy of the current standards and the need to provide

³⁷ Nationwide PM_{2.5} estimates have been derived from the current PM air quality data base, but reflect a significant degree of uncertainty due to the highly variable relationship between PM_{2.5} and PM₁₀ air quality values across locations and seasons (Fitz-Simons et al., 1996). The American Iron and Steel Institute (AISI) submitted a useful data base (Cooper Associates, 1997) on PM_{2.5}/PM₁₀ relationships that examines both these predictions and the issue of equivalence. An EPA examination of this material, which found some problems with the analysis and with commenters' conclusions that appear inconsistent with the Cooper report, is included in the Response to Comments.

additional protection as articulated in Unit II.B. of this preamble. The Administrator believes that, despite well recognized uncertainties, the consistency and coherence of the epidemiological evidence and the seriousness of the health effects require a more protective response than provided by "equivalence" or a marginal strengthening of the standards. Moreover, EPA believes that the standard levels should be based on the most recent assessment of the scientific criteria for PM, not on applying uncertain ratios to standard decisions based on much more limited evidence in 1987. The Administrator also rejects the premise of some³⁸ who suggest that adopting a standard that prompts little or no additional control would cause no delay in risk reduction as compared to conducting monitoring and research now and setting a more stringent standard after the next review. These comments do not consider the realities of implementing air quality standards, which ensure that such an approach would add several years to the risk reduction process. Thus, aside from her obligations under the statute,³⁹ the Administrator believes that the most prudent and appropriate course is to establish appropriately protective standards now that put into motion monitoring and strategy development programs, while at the same time pursuing an expanded research program to improve implementation and to inform the next periodic review of the criteria and standards.

In sharp contrast to the commenters discussed immediately above, a number of other commenters strongly supported standard levels more stringent than those proposed by EPA. These commenters supported EPA's conclusions regarding the epidemiological studies, but would place much less weight on uncertainties related to the concentration-response relationships for PM_{2.5} as a surrogate for PM and the relative importance of various PM components. Based on their evaluation of the information, and citing the support of some CASAC panel members, these commenters variously recommended 24-hour PM_{2.5} standards as low as 18 to 20 µg/m³ and annual standards of 10 to 12 µg/m³.⁴⁰

EPA notes that setting such standards would result in commensurate reductions in

³⁸ Some commenters suggest that CASAC and EPA support for PM_{2.5} standards is based on the need to stimulate additional monitoring and research. While the Administrator agrees that the additional monitoring and research that would accompany establishment of equivalent or marginally tighter PM_{2.5} standards are very important goals, they do not form an adequate rationale for establishing air quality standards.

³⁹ As stated previously, section 109(d) of the Act requires that, after reviewing the existing criteria and standards for PM, the Administrator make such revisions in the standards and promulgate such new standards as are appropriate under section 109(b) of the Act.

⁴⁰ This range of levels for a 24-hour PM_{2.5} standard is close to the lower bound levels recommended by four CASAC panel members (20 µg/m³); no member supported an annual PM_{2.5} standard as low as 10 to 12 µg/m³.

health risks only if, in fact, there is a continuum of health risks down to the lower end of the ranges of air quality observed in the key epidemiological studies, and only if the reported associations are, in fact, causally related to PM_{2.5} at the lowest concentrations measured. Setting standards at low levels where the possibility of effects thresholds is greater, and where there is greater potential that other elements in the air pollution mix (or some subset of particles within the fine fraction) become more responsible for (or modify) the effects being causally attributed to PM_{2.5}, might result in regulatory programs that go beyond those that are needed to effectively reduce risks to public health. While placing substantial weight on the results of the key health studies in the higher range of concentrations observed, EPA is persuaded that the inherent scientific uncertainties are too great to support standards based on the lowest concentrations measured in such studies, which approach the maximum range of PM_{2.5} values estimated for short-term background conditions.

Having considered the comments reflecting the two contrasting views summarized above in this unit, the Administrator concludes that the approach she set forth in the proposal is the most appropriate for selecting levels for annual and 24-hour PM_{2.5} standards. This approach focuses primarily on standard levels designed to limit annual PM_{2.5} concentrations to somewhat below those where the body of epidemiological evidence is most consistent and coherent, in recognition of both the strengths and the limitations of the full range of scientific and technical information on the health effects of PM, as well as associated uncertainties, as interpreted by the Criteria Document, Staff Paper, and CASAC. The Administrator believes that this approach appropriately reflects the weight of the evidence as a whole.

In identifying PM_{2.5} standard levels consistent with this overall approach, the Administrator has placed greatest weight on those epidemiological studies reporting associations between health effects and direct measures of fine particles, most notably those recent studies conducted in North America (summarized in Tables V-12 and V-13 of the Staff Paper).⁴¹ Key considerations and study

⁴¹ Some confusion is apparent in comments regarding the basis on which the Administrator selected levels for the proposed PM_{2.5} standards, with some commenters suggesting two or at most three studies were used, and others suggesting that EPA relied extensively on uncertain conversion factors to estimate levels for the standards. These comments are in error. To clarify, as stated in the proposal, the Administrator is basing her decision to revise the standards on the full range of PM health effects studies summarized in the Criteria Document and Staff Paper, but in selecting specific levels for PM_{2.5} standards, is relying chiefly on U.S. and Canadian studies, listed in Tables V-12 and V-13 of the Staff Paper, that measured fine PM levels. To ease identification and use of these key studies, the short-term exposure studies and key PM air quality statistics are cited in Koman (1996) and all long-term exposure studies are cited in this preamble. The referenced memorandum (Koman, 1996) has been updated (Koman,

results upon which this approach is based are presented as follows.

As previously discussed, the Administrator has concluded that it is appropriate to select the level of the annual standard so as to protect against the range of effects associated with both short- and long-term exposures to PM, with the 24-hour standard level selected to provide supplemental protection against peak concentrations that might occur over limited areas and/or for limited time periods. In selecting the level for the annual standard, therefore, the Administrator has considered both short- and long-term exposure studies.

In accordance with EPA staff and CASAC views on the relative strengths of the epidemiological studies, the Administrator has placed greater emphasis on the short-term exposure studies in selecting the level of the annual standard. The approach she took to this issue consisted of determining a provisional level based on the short-term exposure studies, and then determining whether the long-term exposure studies are consistent with that level or, instead, suggest the need for a lower level. The effects estimates from the short-term exposure studies (in Table V-12 of the Staff Paper) are based on analyses of daily PM_{2.5} concentrations that occurred over the course of the study period. While effects may occur over the full range of concentrations observed in the studies, consistent with the discussion of this issue in Unit II.D. of this preamble, the strongest evidence for short-term PM_{2.5} effects occurs at concentrations near the long-term (e.g., annual) average. More specifically, the strength of the evidence of effects increases for concentrations that are at or above the long-term (e.g., annual) mean levels reported for these studies.⁴² Given the serious nature of the potential effects, the Administrator believes it is both prudent and appropriate to select a level for an annual standard at or below such concentrations. An examination of the long-term means from the combined six city analyses of daily mortality (Schwartz et al., 1996a) and morbidity (Schwartz et al., 1994), together with those from studies in individual cities for which statistically significant PM-effects associations are reported (from Table V-12 in the Staff Paper), finds mean concentrations ranging from about 16 to about 21 µg/m³ (Koman, 1996; 1997). In addition, the mean concentrations in cities where short-term

1997) to clarify key aspects of the studies cited and relevant air quality statistics. In accordance with EPA and CASAC views on the relative strength of these studies, greater weight is placed on short-term exposure studies than on long-term exposure studies. Where studies found statistically significant associations with PM_{2.5} components (e.g., sulfates and/or acids, in Thurston et al., 1994; Dockery et al., 1996), the corresponding PM_{2.5} or PM_{2.1} values from the study are cited. No conversions were made from the original measurements used in these studies.

⁴² As discussed in the proposal and Appendix E of the Staff Paper (U.S. EPA, 1996b, p. E-4), there is generally greatest statistical confidence in observed associations for levels at and above the mean concentration.

exposure associations are characterized in the Criteria Document as nearly statistically significant (U.S. EPA, 1996a, p. 13-40) range from about 11 µg/m³ to 30 µg/m³. Taken together, and placing greatest weight on those studies that were clearly statistically significant, this evidence suggests that an annual standard level of 15 µg/m³ is appropriate to reduce the risk of effects from short-term exposure to fine particles.

Before reaching a final conclusion, the Administrator also examined this level in light of the effects reported in epidemiological studies of long-term exposures to fine particles (Table V-13 in the Staff Paper), which may reflect the accumulation of daily effects over time as well as potential effects uniquely associated with long-term exposures. Even though subject to additional uncertainties, the long-term exposure studies provide important insights with respect to the overall protection afforded by an annual standard. These studies were examined for general consistency and support for the levels derived from the short-term exposure studies, and to determine whether they provide evidence that a more stringent level is needed.

The most direct comparison with the daily fine particle mortality studies is provided by two long-term prospective cohort studies (Dockery et al., 1993; Pope et al., 1995). The annual mean PM_{2.5} concentration for the multiple cities included in these studies (6 and 50 cities, respectively) was 18 µg/m³ (Dockery et al., 1993), and about 21-22 µg/m³ for the larger Pope et al. (1995) study.⁴³ The Staff Paper assessment of the concentration-response results from Dockery et al. (1993) concluded that the evidence for increased risk was more apparent at annual concentrations at or above 15 µg/m³ (Table E-3; U.S. EPA, 1996b).⁴⁴ EPA notes that the estimated mean values for most of the cities in Pope et al. (1995) are above 15 µg/m³. As noted in the Staff Paper and the Criteria Document, the estimated magnitude of effects in both long-term exposure mortality studies may be related to higher historical concentrations than the affected communities experienced during the time period of the studies; this consideration suggests that a level of 15 µg/m³ would incorporate a margin

⁴³ Based on a public comment, EPA found that the mean of 18 µg/m³ in Pope et al. (1995) reported in the Criteria Document and elsewhere was actually the mean of median values. Based on typical air quality relationships, the conventional arithmetic mean would be approximately 21 to 22 µg/m³ (Freas, 1997). The lowest median concentration measured in this study (9 µg/m³), which was relied upon by some commenters as a basis for annual standards of 10 µg/m³, is about 11 to 12 µg/m³ as an arithmetic mean.

⁴⁴ Based on public comments and a further evaluation of the underlying study, EPA concludes that the comparable assessment of the concentration-response function summarized in Table E-3 for Pope et al. (1995) is not appropriate, because it was based on a supplemental "ecologic" comparison for these cities and not on the far more reliable prospective-cohort analysis that was the main focus of the paper.

of safety. An examination of morbidity effects and long-term exposures is provided by the recent "24 city" studies, which found that reduced lung function and increased respiratory symptoms in children followed the gradient in annual mean concentrations of fine particles and/or acid-sulfate components of fine particles (Raizenne et al., 1996; Dockery et al., 1996). The results indicate a greater likelihood of effects at annual mean PM_{2.1} levels above about 15 µg/m³ (U.S. EPA, 1996b; Figure V-7). In the judgment of the Administrator, these studies are consistent with a standard level of 15 µg/m³. While they provide some suggestion of risks extending to lower concentrations, they do not provide a sufficient basis for establishing a lower annual standard level.

Taking the epidemiological studies of both short- and long-term exposures together, the Administrator believes the concordance of evidence for PM effects and associated levels provides clear support for an annual PM_{2.5} standard level of 15 µg/m³. This level is below the range of annual data most strongly associated with both short- and long-term exposure effects, and because even small changes in annual means in this concentration range can make significant differences in overall risk reduction and total population exposures, the Administrator believes it will provide an adequate margin of safety against the effects observed in these epidemiological studies. Moreover, the means in areas where PM_{2.5} concentrations were statistically significantly associated with daily mortality (about 16 to 21 µg/m³) reflect a 7 to 9-year average; thus, the use of a 3-year mean will provide additional protection. Although the possibility of effects at lower annual concentrations cannot be excluded, the evidence for that possibility is highly uncertain and, as previously discussed, the likelihood of significant health risk, if any, becomes smaller as concentrations approach the lower end of the range of air quality observed in the key epidemiological studies and/or background levels.

The final annual standard will provide substantial protection against short-term as well as long-term exposures to particles. Nevertheless, for the reasons specified above, a spatially averaged annual standard cannot be expected to offer an adequate margin of safety against the effects of all potential short-term exposures in areas with strong local or seasonal sources. The broad-based community studies considered in this review generally could not evaluate such peak exposure conditions directly. Given the public health purposes of the 24-hour standard, the Administrator believes it should be set at a level that generally supplements the control afforded by an annual standard and proposed an approach based on providing a reasonable degree of protection against the peak levels observed or expected in communities where health effects have been associated with daily levels of fine particles.

For the reasons specified in the previous unit, the Administrator has decided to use a 98th percentile concentration-based form of the standard. As noted in the proposal, the 98th percentile 24-hour PM_{2.5} concentrations in cities with statistically significant or nearly significant short-term fine particle exposure-effects associations ranged from 34 µg/m³ to as high as 90 µg/m³ (Koman, 1996, 1997). Based on an examination of these results, EPA originally proposed a level for the 24-hour standard of 50 µg/m³, and solicited comments on higher and lower alternative levels.

In considering comments on alternative levels for the purpose of making a final decision on the 24-hour standard, the Administrator recognizes the significant uncertainties in identifying the extent of the incremental risk associated with single peak exposures to PM_{2.5} in areas where the annual standard is met. Clearly, the risks associated with the 98th percentile air quality data used in the selecting the proposed level are from the same study cities that experienced long-term levels at varying amounts above that selected for the annual standard. It is unclear what risks might have been associated with such peak levels had the long-term averages in these areas been below that selected for the annual standard. Regardless of this uncertainty, it is clear that reducing the annual concentrations in such areas to that of the annual standard would reduce the risk associated with peak days, whatever the magnitude, as well as that associated with the far more numerous days with concentrations near the annual average. Given these uncertainties and the significant degree of protection afforded by the annual standard, the Administrator is persuaded that it is appropriate to adopt a different approach for selecting the levels of the 24-hour standard than the one proposed.

In making a final decision on an appropriate level for the 24-hour standard, the Administrator considered several key factors: the significant protection afforded against short-term exposures by the annual PM_{2.5} standard; the role of the 24-hour standard in providing supplemental protection against peak exposures not addressed by the annual standard; the air quality and effects information in the studies cited above; the uncertainties in the risks associated with infrequent and isolated peak exposures in areas that meet the annual standard; the range of levels recommended by EPA staff and CASAC panel members; and the extensive public comment on the alternative levels proposed, which ranged between 20 and 65 µg/m³. Because of the approach of establishing the annual standard as the controlling standard, and, in particular, the decision to set the level at the lower end of the annual range, there is no need to consider levels in the lower portion of the 24-hour range below the level proposed. Therefore, the Administrator focused on evaluating the

margin of safety associated with levels between 50 and 65 µg/m³.

As has been discussed in previous units, the extent of total risk over the course of a year associated solely with a limited number of peak exposures is uncertain, but it is considerably smaller than that associated with the entire air quality distribution. Further, the risk associated with infrequent peak 24-hour exposures in otherwise clean areas is not well enough understood at this time to provide a basis for selecting the more restrictive levels in the range of 50 to 65 µg/m³. On the other hand, it is clear that any standard level within this range would provide some margin of safety. Taking into account the factors outlined above, the Administrator has concluded that a 24-hour standard at the level of 65 µg/m³ would provide an effective limit in the role as a supplement to the annual standard. This level is at the upper end of the range recommended by staff and most CASAC panel members, and below the levels suggested by some CASAC panel members and by a number of public commenters. Although this level is not risk free, the Administrator believes that it would provide an appropriate degree of additional protection over that provided by the annual PM_{2.5} standard. Accordingly, after weighing these factors in light of the scientific uncertainties, the Administrator believes that a 98th percentile 24-hour PM_{2.5} standard of 65 µg/m³ would provide an adequate margin of safety against infrequent or isolated peak concentrations that could occur in areas that attain the annual standard of 15 µg/m³.

In the Administrator's judgment, the factors discussed above provide ample reason to believe that both annual and 24-hour PM_{2.5} standards are appropriate to protect public health from adverse health effects associated with short- and long-term exposures to ambient fine particles. Further, she believes these factors provide a clear basis for judging that an annual PM_{2.5} standard set at 15 µg/m³, in combination with a 24-hour standard set at 65 µg/m³, will protect public health with an adequate margin of safety.

G. Conclusions Regarding the Current PM₁₀ Standards

1. *Averaging time and form.* In conjunction with PM_{2.5} standards, the new function of PM₁₀ standard(s) is to protect against potential effects associated with coarse fraction particles in the size range of 2.5 to 10 µm. Coarse fraction particles are plausibly associated with certain effects from both long- and short-term exposures (EPA 1996a,b). Based on qualitative considerations, deposition of coarse fraction particles in the respiratory system could be expected to aggravate effects in individuals with asthma. The Criteria Document and Staff Paper found support for this expectation in limited epidemiological evidence on the effects of coarse fraction particles, suggesting that aggravation of asthma and respiratory

infections and symptoms may be associated with daily or episodic increases in PM₁₀ that are dominated by coarse fraction particles. The potential build-up of insoluble coarse fraction particles in the lung after long-term exposures to high levels should also be considered.

Based on assessments of the available information in the Criteria Document and Staff Paper, both the staff and CASAC recommended retention of an annual PM₁₀ standard. The staff, with CASAC concurrence, recommended retention of the current annual arithmetic mean form of the standard, which is the same form being adopted for the annual PM_{2.5} standard. As noted in the staff assessment, the current annual PM₁₀ standard offers substantial protection against the effects of both long- and short-term exposure to coarse fraction particles. Public comment was nearly unanimous in recommending retention of this standard. The Administrator therefore has decided to continue a long-term PM₁₀ standard as an annual arithmetic mean, averaged over 3 years.

The staff and CASAC also recommended that consideration be given to retention of a 24-hour standard to provide additional protection against potential effects of short-term exposures to coarse fraction particles. The staff, with CASAC concurrence, also recommended that if a 24-hour standard is retained, the form of the standard should be revised to provide a more robust target for coarse fraction particle controls. The Administrator originally proposed a 98th percentile form for the 24-hour PM₁₀ standard based primarily on the reasons outlined above in this unit regarding the proposed form of the 24-hour PM_{2.5} standard.

The EPA received few comments supporting elimination of the 24-hour PM₁₀ standard. The main exceptions were some industries, most notably the mining industry, which as noted above in this unit, argued that the available data provide little evidence for coarse particle effects at current ambient levels. These groups, who generally opposed PM_{2.5} standards, also argued that the daily PM₁₀ standard could be eliminated if PM_{2.5} standards were set. Based on the potential aggravation of respiratory symptoms from short-term exposure to coarse fraction particles discussed in the Criteria Document and by numerous commenters, as well as the recommendations of a majority of CASAC panelists who also supported PM_{2.5} standards, the Administrator concludes it is appropriate to retain a 24-hour PM₁₀ standard.

In general, comments received on the form of the 24-hour PM₁₀ standard paralleled those on the form of the PM_{2.5} standard. Substantial concerns were expressed by environmental groups, some States, and others that the 98th percentile would not provide an adequate limit on the number and magnitude of 24-hour peak PM₁₀ excursions. While a number of these commenters suggested keeping the

current 1-expected-exceedance form, EPA believes that a concentration-based percentile form offers significant advantages, as outlined above in this unit, for both PM indicators. Some air pollution control officials, who were concerned about the extent to which the 24-hour PM₁₀ standard would be relaxed under the proposed form, suggested consideration of a 99th percentile form with increased monitoring as an appropriately protective form. Other commenters, particularly some industry groups and some States, strongly supported concentration-based percentile forms, with some recommending consideration of the 95th percentile form.

The proposal noted that a percentile value selected closer to the "tail" of the air quality distribution (e.g., a 99th or greater percentile) would not significantly increase stability as compared to the current form. However, an association of 8 State air pollution agencies commented that a 99th percentile form could provide increased stability if combined with a daily or 1-in-3-day sampling frequency and with greater data capture. In addition, EPA notes that this concentration-based form is inherently more stable than the current exceedance-based form.

Many of these and other commenters were concerned that the uncertainties in the available scientific information on the effects of coarse particles were a reason to be concerned that, assuming the current standard level was kept, a 98th percentile form would represent a significant relaxation in protection relative to the current standards. Unlike the situation for the new PM_{2.5} standards, in the case of the PM₁₀ standards, the 24-hour standard has generally been the "controlling" standard, making changes to the form of the 24-hour standard potentially more significant to the overall national level of protection afforded. Given the uncertainties in the available scientific evidence with respect to the potential health effects of short-term exposures to coarse fraction particles, the Administrator is persuaded that the somewhat more cautious approach with respect to revising the 24-hour PM₁₀ standard recommended by many commenters is appropriate. The only approaches available for increasing the extent of protection for this standard as compared to that of the proposed standard involve modifying the form or reducing the level. For reasons discussed in the following section, the Administrator believes it is not appropriate to revise the level of the standard. In order to provide adequate protection against the potential risk associated with multiple short-term peak exposures to coarse fraction particles, the Administrator accepts commenters' recommendations to decrease the frequency of peak values, while still providing for a more stable control target than afforded by the current 1-expected-exceedance form. Therefore, the Administrator concludes that the 99th percentile concentration-based form, averaged over 3 years, and combined with

more frequent sampling, would be an appropriate form for a 24-hour PM₁₀ standard.

2. *Levels for the annual and 24-hour PM₁₀ standards*—a. *Annual PM₁₀ standard.* As a result of the more limited information for coarse fraction particles, the Administrator's approach for selecting a level of the standard is directly related to the approach taken in the last review of the PM NAAQS. In that review, evidence from limited quantitative studies was used in conjunction with support from the qualitative literature in selecting the level of the current annual PM₁₀ standard. In the current review, the staff assessment of the major quantitative basis for the level of that standard (Ware et al., 1986), together with a more recent related study (Dockery et al., 1989), recommended the same range of levels of concern (40 to 50 µg/m³) as in the 1986 staff paper. The staff concludes that it is possible, but not certain, that coarse fraction particles, in combination with fine particles, may have influenced the observed effects at these levels. Based on particle deposition considerations, it is possible that cumulative deposition of coarse fraction particles could be of concern in children, who are more prone to be active outdoors than sensitive adult populations.

Qualitative evidence of other long-term coarse particle effects, most notably from long-term build-up of silica-containing materials, supports the need for a long-term standard, but does not provide evidence of effects below the range of 40 to 50 µg/m³ (U.S. EPA, 1996a, p. 13-79). The staff concludes that the qualitative evidence with respect to biological aerosols also supports the need to limit coarse materials, but should not form the major basis for a national standard (U.S. EPA, 1996a, p. 13-79). In addition, staff notes that the nature and distribution of such materials, which vary from endemic fungi (e.g., valley fever) to pollens larger than 10 µm, are not appropriately addressed by traditional air pollution control programs.

Based on its review of the available information, CASAC found "a consensus that retaining an annual PM₁₀ NAAQS at the current level is reasonable at this time" (Wolff, 1996b). With few exceptions, public comments supported levels at least as stringent as the current annual PM₁₀ standard.⁴⁵ Taking into account these comments and the above considerations, as

⁴⁵ Some commenters, including some environmental groups and the State of California (Cal EPA, 1997), suggested that the large number of recent studies showing effects at PM₁₀ levels below the current standards provides a basis for establishing stricter annual and 24-hour PM₁₀ standards, in conjunction with PM_{2.5} standards. As discussed in Units II.B. and C. of this preamble, while these studies could be used either to tighten the PM₁₀ standards or to add standards that tighten control of the fine fraction of PM₁₀, the weight of evidence from all of the relevant information more readily supports the development of additional protection for the PM_{2.5} fraction.

more fully detailed in the Staff Paper and the CASAC recommendations, the Administrator has decided to retain the current annual PM₁₀ standard of 50 µg/m³ to protect against the known and potential effects of long-term exposure to coarse fraction particles.

b. *24-hour PM₁₀ standard.* As discussed above in this unit, EPA staff and CASAC also recommended that consideration be given to a 24-hour standard for coarse fraction particles as measured by PM₁₀. Unlike the case for the annual standard, however, the staff found that the original quantitative basis for the level of the current 24-hour PM₁₀ standard (150 µg/m³) is no longer appropriate. Instead, the staff found that the main quantitative basis for a short-term standard is provided by the two recent community studies of exposure to fugitive dust (Gordian et al., 1996; Hefflin et al., 1994). Because these studies reported multiple large exceedances of the current 24-hour standard, and because of limitations in the studies themselves, the staff concluded that they provide no basis to lower the level of the standard below 150 µg/m³. Moreover, staff concluded that none of the qualitative literature regarding the potential effects of short-term exposure to coarse particles provides a basis for a lower standard level. Both EPA staff and CASAC recommended that if a 24-hour PM₁₀ standard is retained, the level of the standard should be maintained at 150 µg/m³, although with a revised form. Beyond the comments summarized above recommending elimination of the 24-hour standard, no commenters recommended a less stringent level, while some others, as summarized above in this unit, recommended more stringent levels. Most comments favored the current level.

Having considered these factors and the public comments, the Administrator judges that, retention of a 24-hour PM₁₀ standard at the level of 150 µg/m³ with a 99th percentile form is appropriate and will provide adequate protection against the known and potential effects of short-term coarse fraction particle exposures that have been identified to date in the scientific literature.

H. Final Decisions on Primary PM Standards

For the reasons discussed above in this unit, and taking into account the information and assessments presented in the Criteria Document and the Staff Paper, the advice and recommendations of CASAC, and public comments received on the proposal, the Administrator is revising the current PM NAAQS by adding new PM_{2.5} standards and by revising the form of the current 24-hour PM₁₀ standard. Specifically, the Administrator is making the following revisions:

- (1) The suite of PM standards is revised to include an annual primary PM_{2.5} standard and a 24-hour PM_{2.5} standard.
- (2) The annual PM_{2.5} standard is met when the 3-year average of the annual arithmetic

mean PM_{2.5} concentrations, from single or multiple community-oriented monitors (in accordance with EPA's final rule on monitoring siting guidance, 40 CFR part 58, published in a separate document elsewhere in this issue of the **Federal Register**) is less than or equal to 15 µg/m³, with fractional parts of 0.05 or greater rounding up.

(3) The 24-hour PM_{2.5} standard is met when the 3-year average of the 98th percentile of 24-hour PM_{2.5} concentrations at each population-oriented monitor within an area is less than or equal to 65 µg/m³, with fractional parts of 0.5 or greater rounding up.

(4) The form of the current 24-hour PM₁₀ standard is revised to be based on the 3-year average of the 99th percentile of 24-hour PM₁₀ concentrations at each monitor within an area.

In addition, the Administrator is retaining the current annual PM₁₀ standard at the level of 50 µg/m³, which is met when the 3-year average of the annual arithmetic mean PM₁₀ concentrations at each monitor within an area is less than or equal to 50 µg/m³, with fractional parts of 0.5 or greater rounding up.

As discussed below in Units V. and VI. of this preamble, data handling conventions and completeness criteria for the revised standards are being established (40 CFR part 50, Appendix N). The reference method for monitoring PM as PM₁₀ for the revised standards has been established (40 CFR part 50, Appendix M). A new reference method is being established for monitoring PM as PM_{2.5} (40 CFR part 50, Appendix L). In a separate document published elsewhere in this issue of the **Federal Register**, EPA is providing opportunity for public comment on supplemental information relating to the new reference method for monitoring PM as PM_{2.5} (40 CFR part 50, Appendix L).

As indicated previously, EPA plans to propose related revisions to the Pollutant Standards Index for PM (40 CFR 58.50) and the significant harm level program (40 CFR 51.66) at a later date.

III. Rationale for the Secondary Standards

The Criteria Document and Staff Paper examined the effects of PM on such aspects of public welfare as visibility, materials damage, and soiling. The following discussion of the rationale for revising the secondary standards for PM focuses on those considerations most influential in the Administrator's decision.

A. Need for Revision of the Current Secondary Standards

1. *Visibility impairment.* This unit of the document presents the Administrator's decision to address the welfare effects of PM on visibility by setting secondary standards identical to the suite of PM_{2.5} primary standards, in conjunction with the establishment of a regional haze program

under section 169A of the Act.⁴⁶ In the Administrator's judgment, this approach is the most effective way to address visibility impairment given the regional variations in concentrations of non-anthropogenic PM as well as other regional factors that affect visibility, such as humidity. By augmenting the protection provided by secondary standards set identical to the suite of PM_{2.5} primary standards with a regional haze program, the Administrator believes that an appropriate degree of visibility protection can be achieved in the various regions of the country.

In coming to this decision, the Administrator took into account several factors, including: The pertinent scientific and technical information in the Criteria Document and Staff Paper, difficulties inherent in attempting to establish national secondary standards to address visibility impairment, the degree of visibility improvement expected through attainment of secondary standards equivalent to the suite of PM_{2.5} primary standards, the effectiveness of addressing the welfare effects of PM on visibility through the combination of a regional haze program and secondary standards for PM_{2.5} equivalent to the suite of primary standards, and comments received during the public comment period. The Administrator's consideration of each of these factors is discussed below in this unit.

The Administrator first concluded, based on information presented and referenced in the Criteria Document and Staff Paper, that particulate matter can and does produce adverse effects on visibility in various locations, depending on the PM concentrations involved and other factors discussed below. It has been demonstrated that impairment of visibility is an important effect of PM on public welfare, and that it is experienced throughout the United States, in multi-state regions, urban areas, and remote mandatory Class I Federal areas⁴⁷ alike. Visibility is an important welfare effect because it has direct significance to people's enjoyment of daily activities in all parts of the country. Individuals value good visibility for the well-being it provides them directly, both where they live and work, and in places where they enjoy recreational opportunities. Visibility is highly valued in significant natural areas, such as national parks and wilderness areas, because of the special emphasis given to protecting these lands now

⁴⁶ Congress adopted section 169A of the Act because of concern that the NAAQS and Prevention of Significant Deterioration programs might not provide adequate visibility protection nationally, particularly for "areas of great scenic importance." See H.R. Rep. No. 95-294, at 203-205 (1977).

⁴⁷ There are 156 mandatory Class I Federal areas protected by the visibility provisions in sections 169A and 169B of the Act. These areas are defined in section 162 of the Act as those national parks exceeding 6,000 acres, wilderness areas and memorial parks exceeding 5,000 acres, and all international parks which were in existence on August 7, 1977.

and for future generations. The Criteria Document cites many studies designed to quantify the benefits associated with improvements in visibility.

The Administrator considered information from the Staff Paper and Criteria Document regarding the effect of the composition of particulate matter on visibility. Visibility conditions are determined by the scattering and absorption of light by particles and gases, from both natural and anthropogenic sources. Visibility can be described in terms of visual range, light extinction, or deciview⁴⁸. The classes of fine particles principally responsible for visibility impairment are sulfates, nitrates, organic matter, elemental carbon (soot), and soil dust. Fine particles are more efficient per unit mass at scattering light than coarse particles. The scattering efficiency of certain classes of fine particles, such as sulfates, nitrates, and some organics, increases as relative humidity rises because these particles can absorb water and grow to sizes comparable to the wavelength of visible light. In addition to limiting the distance that one can see, the scattering and absorption of light caused by air pollution can also degrade the color, clarity, and contrast of scenes.

The Administrator next considered what would be an appropriate level for a secondary standard to address adverse effects of particulate matter on visibility. The determination of a single national level is complicated by regional differences in visibility impairment due to several factors, including background and current levels of PM, composition of particulate matter, and average relative humidity.

The Criteria Document and Staff Paper describe estimated background levels of PM and natural light extinction. In the United States, estimated annual mean background levels of PM_{2.5} are significantly lower in the West than in the East. Based on estimated background fine particle and light extinction levels summarized in Table VIII-2 of the Staff Paper, naturally occurring visual range in the East is approximately 105 to 195 kilometers, whereas in the West it is approximately 190 to 270 kilometers. This significant regional difference in estimated background conditions results from two main factors. First, in the western United States, visibility is more sensitive to an additional 1-2 µg/m³ of PM_{2.5} in the atmosphere than in the eastern United States. Secondly, light scattering is increased for certain particles (e.g., sulfates, nitrates, and some organics)

⁴⁸ Visual range can be defined as the maximum distance at which one can identify a black object against the horizon sky. It is typically described in miles or kilometers. Light extinction is the sum of light scattering and absorption by particles and gases in the atmosphere. It is typically expressed in terms of inverse megameters (Mm⁻¹), with larger values representing poorer visibility. The deciview metric describes perceived visual changes in a linear fashion over its entire range, analogous to the decibel scale for sound. A deciview of 0 represents pristine conditions. Under many scenic conditions, a change of 1 deciview is considered perceptible by the average person.

due to higher average relative humidity in the East.

The combination of naturally occurring and manmade emissions also leads to significant differences in current visibility conditions between the eastern United States, 23–39 kilometers average visual range, and western United States, 55–150 kilometers average visual range. Table VIII-4 of the Staff Paper indicates that the current level of annual average light extinction in several western locations, such as the Colorado Plateau, is about equal to the level of background light extinction, i.e., the level generally regarded as representing the absence of anthropogenic emissions in North America, in the East. This regional difference is due to higher background particle concentrations in the East, a composition of fine particles in the East that, in association with higher eastern humidity levels, is more efficient at light scattering, and significantly lower concentrations of anthropogenic PM in remote western locations as compared with remote eastern sites.

Because of these regional differences, it is the Administrator's judgment that a national secondary standard intended to maintain or improve visibility conditions on the Colorado Plateau or other parts of the West would have to be set at or even below natural background levels in the East, which would effectively require elimination of all eastern anthropogenic emissions. Conversely, a national secondary standard that would achieve an appropriate degree of visibility improvement in the East would permit further degradation in the West. Due to this regional variability in visibility conditions created by differing background fine particle levels, fine particle composition, and humidity effects, the Administrator finds that addressing visibility solely through setting more stringent national secondary standards would not be an appropriate means to protect the public welfare from adverse impacts of PM on visibility in all parts of the country.⁴⁹ Aside from the problem of regional variability, the Administrator has also determined that the Agency currently lacks sufficient information to establish a level for a national secondary standard that would represent a threshold above which visibility conditions would always be adverse and below which visibility conditions would always be acceptable. Because visibility varies not only with PM concentration, but also with PM composition and humidity levels, attaining even a low concentration of fine particles might or might

not provide adequate protection, depending on these factors.

The Administrator next assessed potential visibility improvements⁵⁰ that would result from attainment of the new primary standards for PM_{2.5}. The spatially averaged form of the annual standard is well suited to the protection of visibility, which involves effects of PM throughout an extended viewing distance across an urban area. Indeed, as the generally controlling standard focused on reducing urban and regional scale fine particle levels, most of the visibility protection provided by the PM_{2.5} primary standards would be derived from the annual standard. In many cities having annual mean PM_{2.5} concentrations exceeding 17 µg/m³, improvements in annual average visibility resulting from attainment of the new annual PM_{2.5} primary standard are expected to be perceptible (i.e., to exceed 1 deciview). Based on annual mean PM_{2.5} data reported in Table 12-2 of the Criteria Document and Table V-12 in the Staff Paper, many cities in the Northeast, Midwest, and Southeast, as well as Los Angeles, would be expected to see perceptible improvement in visibility if the annual PM_{2.5} primary standard is attained.

In Washington, DC, for example, where the IMPROVE network⁵¹ shows annual mean PM_{2.5} concentrations at about 19 µg/m³ during 1992–1995, approximate annual average visibility would be expected to improve from 21 km visual range (29 deciview) to 27 km (27 deciview). Annual average visibility in Philadelphia, where annual PM_{2.5} levels have been recently measured at 17 µg/m³, would be expected to change from about 24 to 27 km, an improvement of about 1 deciview. In Los Angeles, where recent data shows annual mean PM_{2.5} concentrations at approximately 30 µg/m³, visibility would be expected to improve from about 19 to 34 km (30 to 24 deciview) if the new annual primary PM_{2.5} standard is attained.

It is important to note that some urban areas, many in the eastern United States, would be expected to have annual mean PM_{2.5} concentrations reduced below the primary standard level of 15 µg/m³ when implementation of regional control strategies for PM and other air quality programs, such as those addressing acid rain and mobile sources, are taken into account together. On

the other hand, some urban areas with annual PM_{2.5} levels at or below the 15 µg/m³ level would be expected to see little, if any, improvement in annual average visibility. This may be particularly true of certain western urban areas that are dominated by coarse rather than fine particles.

The Administrator also considered the potential effect on urban visibility if the 24-hour 98th percentile PM_{2.5} standard of 65 m³ is attained. In areas with violations caused by localized hot spots, the 24-hour standard might have little effect other than on visible source emissions. In other areas, for example, with seasonally high woodsmoke, a more areawide improvement is possible. In such urban areas, attainment of the 24-hour standard would be expected to reduce, to some degree, the number and intensity of "bad visibility" days, i.e., the 20% of days having the greatest impairment over the course of a year. For example, maximum 24-hour PM_{2.5} concentrations have been recorded in recent years at over 140 µg/m³ at several California locations. If the level and frequency of peak PM concentrations are reduced, improvements would be expected in those days where visibility is worst, even in urban areas having annual averages below the annual PM_{2.5} primary standard.

Having concluded that attainment of the annual and 24-hour PM_{2.5} primary standards would lead to visibility improvements in many eastern and some western urban areas, the Administrator also considered potential improvements to visibility on a regional scale. In the rural East, attainment of the PM_{2.5} primary standards could result in regional visibility improvement, e.g., in certain mandatory Class I Federal areas such as Shenandoah and Great Smoky Mountains National Park, if regional control strategies are adopted and carried out in order to reduce the impact of long-range transport of fine particles such as sulfates. Fine particle emission reductions achieved by other air quality programs, such as those to reduce acid rain or mobile source emissions, are also expected to improve Eastern regional visibility conditions (U.S. EPA, 1993). In the West, strategies to attain the primary PM_{2.5} standards are less likely to significantly improve visibility on a regional basis. However, areas downwind from large urban areas, such as Southern California, would likely see some improvement in annual average visibility.

Based on the foregoing, the Administrator concludes that attainment of PM_{2.5} secondary standards set at the level of the primary standards for PM_{2.5} would be expected to result in visibility improvements in the eastern United States at both urban and regional scales, but little or no change in the western United States except in and near certain urban areas. Additionally, the Administrator determined that attainment of secondary standards equivalent to the suite of PM_{2.5} primary standards for particulate matter

⁴⁹ Congress adopted a visibility protection program in section 169A of the Act because it recognized the impracticability of revising the NAAQS to protect visibility in all areas of the country: "It would be impracticable to require a major city such as New York or Los Angeles to meet the same visibility standards as the Grand Canyon and Yellowstone Park." See H.R. Rep. No. 95-294 at 205. (1977)

⁵⁰ Estimates of annual average visibility improvements assume that, on a percentage basis, the reduction for each fine particle component is equal to the % reduction in the mass of fine particles, and that the overall light extinction efficiency of the fine particle pollutant mix does not change. Further, for the estimates presented here, the reductions in fine mass at monitored locations are assumed to reflect the spatial average concentrations through the viewing distance. (Damberg and Polkowsky, 1996.)

⁵¹ IMPROVE (Interagency Monitoring of PROtected Visual Environments) is a visibility monitoring network managed cooperatively by EPA, Federal land management agencies, and State representatives. An analysis of IMPROVE data for 1992–1995 is found in Sisler et al. (1996).

would address some but not all of the effects of particulate matter on visibility. The extent to which these effects would be addressed is expected to vary regionally.

The Administrator then considered the potential effectiveness of a regional haze program to address the remaining effects of particulate matter on visibility (i.e., those that would not be addressed through attainment of secondary standards identical to the suite of PM_{2.5} primary standards). A program to address the widespread, regionally uniform type of haze caused by a multitude of sources is required by sections 169A and 169B of the Act. In 1977, Congress established as a national goal "the prevention of any future, and the remedying of any existing, impairment of visibility in mandatory Class I Federal areas which impairment results from manmade air pollution", section 169A(a)(1) of the Act. The EPA is required by section 169A(a)(4) of the Act to promulgate regulations to ensure that "reasonable progress" is achieved toward meeting the national goal. EPA originally deferred establishment of a program to address regional haze in 1980 due to the need for greater scientific and technical knowledge, but the current Criteria Document and Staff Paper cite information supporting the Administrator's conclusion that the scientific state of understanding and analytical tools are now adequate to develop such a program. Because regional emission reductions are needed to make visibility improvements in mandatory Class I Federal areas, the structure and requirements of sections 169A and 169B of the Act, provide for visibility protection programs that can be more responsive to the factors contributing to regional differences in visibility than can programs addressing a nationally applicable secondary NAAQS. The visibility goal is more protective than a secondary NAAQS since the goal addresses any man-made impairment rather than just impairment at levels determined to be adverse.

Thus, an important factor considered in this review is whether a regional haze program, in conjunction with secondary standards set identical to the suite of PM_{2.5} primary standards, would provide appropriate protection for visibility in non-Class I areas. The Administrator continues to believe that the two programs and associated control strategies should provide such protection due to the regional approaches needed to manage emissions of pollutants that impair visibility in many of these areas. Regional strategies implemented to attain the NAAQS, meet other air program goals, and make reasonable progress toward the national visibility goal in mandatory Class I Federal areas are expected to improve visibility in many urban and non-Class I areas as well. The following recommendation from the 1993 report of the National Research Council, *Protecting Visibility in National Parks and Wilderness Areas*, addresses this point:

Efforts to improve visibility in Class I areas also would benefit visibility outside these areas. Because most visibility impairment is regional in scale, the same haze that degrades visibility within or looking out from a national park also degrades visibility outside it. Class I areas cannot be regarded as potential islands of clean air in a polluted sea.

Before making a final decisions on the secondary standards, the Administrator also considered a number of public comments that addressed this aspect of the proposal. Some commenters suggested setting secondary standards for PM_{2.5} more stringent than the proposed primary standards for the purpose of addressing visibility impairment and other environmental effects. For the reasons discussed above in this unit, however, the Administrator has concluded that this may not be an effective and would not be an appropriate means of protecting against visibility impairment in all parts of the country. Other commenters raised the possibility of establishing a nationally applicable secondary standard defined as a "floor," or increment, above regionally specific background levels of PM_{2.5} or associated visibility. Although this idea is of interest and may warrant further study, the Administrator determined that it was not appropriate to pursue such an approach at this time for two principal reasons. First, the Agency does not currently have adequate scientific information to establish a specific floor or increment level that would protect against adverse effects nationally, nor is it clear as a conceptual matter whether further information would support selection of a single, uniform increment as providing an appropriate degree of protection in all areas of the country. Second, there are serious, unresolved questions about whether such an approach is consistent with the statutory language and purposes of section 109 of the Act.

Other commenters argued that national secondary standards equivalent to the proposed PM_{2.5} primary standards are not necessary or not supported by the Administrator's findings. As noted earlier, however, it is clear that coarse and fine particles can cause adverse effects on visibility and significant quantitative data exist to demonstrate that visibility impairment occurs at small concentrations of PM_{2.5}. Substantial efforts have been put forth to assess the effects of PM on visibility. For example, the Grand Canyon Visibility Transport Commission⁵² spent several years and significant effort studying the effects of pollution on 16 mandatory Class I Federal areas on the Colorado plateau and has made

⁵² EPA established the Grand Canyon Visibility Transport Commission (GCVTC) in 1991 under section 169B of the Act. Section 169B(d) requires visibility transport commissions to assess the "adverse impacts on visibility from potential or projected growth in emissions" and to recommend to EPA measures to remedy such adverse impacts. The Commission issued its final report in June 1996.

recommendations to the Administrator for actions to improve visibility in these areas (GCVTC, 1996). All of the mandatory Class I Federal areas studied by the GCVTC with monitoring data have annual mean PM_{2.5} concentrations below 5 µg/m³ (Sisler, 1996) while also documenting anthropogenic visibility impairment. The Southern Appalachian Mountain Initiative⁵³ is currently assessing air pollution impacts on visibility, terrestrial resources, and aquatic resources in the southeastern U.S. in order to recommend measures to remedy existing and prevent future adverse effects on these air quality related values. The IMPROVE network shows that all of the mandatory Class I Federal areas in the SAMI region have annual mean PM_{2.5} concentrations for 1992-95 between 11.0-13.5 µg/m³ (Sisler, 1996). The inclusion in section 169A of the Act of a national visibility goal of no manmade impairment also places significant value on reducing PM concentrations and resulting visibility impairment to low levels.⁵⁴ The differences between the fine particle levels associated with visibility impairment in eastern and western mandatory Class I Federal areas provide further impetus to act under the provisions of sections 169A and 169B enabling the Administrator to establish a regionally-tailored visibility program to address impairment of visibility in mandatory Class I Federal areas. For these reasons, the Administrator has concluded that a national regional haze program allowing for regional approaches to addressing fine particle pollution, combined with a nationally applicable level of protection achieved through secondary PM_{2.5} standards set equal to the suite of primary standards, would be more effective in addressing regional variations in the adverse effects of PM_{2.5} on visibility than establishing national secondary standards for particulate matter that are lower than the suite of PM_{2.5} primary standards. The Administrator emphasizes that in order to appropriately address the regional differences in adverse effects of particulate matter on visibility, it is essential to establish secondary standards for PM_{2.5} equivalent to the primary standards and an effective new regional haze program. A regional haze program will be particularly important in those areas of the country that do not exceed any of the primary standards for PM_{2.5}, yet still experience significant visibility impairment due to particulate matter. The EPA will propose a regional haze regulation in the near future.

⁵³ The Southern Appalachian Mountain Initiative is a voluntary effort begun in 1993. Participants include eight southeastern States, Federal land managers, EPA, and representatives from industry and environmental groups. A final report has not been issued to date.

⁵⁴ Indeed, Congress recognized when it adopted section 169A that the "visibility problem is caused primarily by emission into the atmosphere of sulfur dioxide, oxides of nitrogen and particulate matter, especially fine particulate matter, from inadequately controlled sources." H.R. Rep. No. 95-294 at 204 (1977).

In addition to providing a more regionally tailored approach than establishing a more stringent national secondary standard, an effective regional haze program will also fulfill the Administrator's regulatory responsibility under sections 169A and 169B of the Act to address both reasonably attributable impairment and regional haze impairment in mandatory Class I Federal areas. Indeed, regional haze has been shown to be the principal cause of visibility impairment in mandatory Class I Federal areas today. Thus, the promulgation of a regional haze program in conjunction with secondary standards for PM_{2.5} equivalent to the suite of primary standards will serve as an appropriate approach for addressing adverse effects of visibility that vary regionally, and it will also establish a comprehensive program for making reasonable progress toward the national visibility goal in mandatory Class I Federal areas by addressing visibility impairment in the form of both source-specific impacts and regional haze. Further, the regional haze rulemaking will fulfill the Administrator's responsibilities to address the visibility protection recommendations of the Grand Canyon Visibility Transport Commission, pursuant to section 169B(e) of the Act.

The Administrator recognizes that people living in certain urban areas may place a high value on unique scenic resources in or near these areas, and as a result might experience visibility problems attributable to sources that would not necessarily be addressed by the combined effects of a regional haze program and secondary standards identical to the suite of primary standards for PM_{2.5}. Commenters from certain western cities and States raised this issue. In the Administrator's judgment, State or local regulatory approaches, such as past action in Colorado to establish a local visibility standard for the City of Denver, would be more appropriate and effective in addressing these special situations because of the localized and unique characteristics of the problems involved. Visibility in an urban area located near a mandatory Class I Federal area can also be improved through State implementation of the current visibility regulations, by which emission limitations can be imposed on a source or group of sources found to be contributing to "reasonably attributable" impairment in the mandatory Class I Federal area. EPA also intends to pursue opportunities to obtain information on urban and non-Class I area visibility through examination of available fine particle monitoring data. Current or planned monitoring networks and initiatives, such as monitoring and chemical analysis of PM_{2.5} in urban and background sites, efforts to better characterize real-time environmental conditions in major populations centers, and new automated airport visibility monitoring networks should provide data needed to evaluate trends in these areas. This

information should help to better characterize the nature and spatial extent of urban and non-Class I visibility problems and thus serve to inform future decisions on NAAQS revisions or other appropriate measures.

Based on all of the considerations discussed, the Administrator has decided to establish secondary standards identical to the suite of PM_{2.5} primary standards, in conjunction with a regional haze program under sections 169A and 169B of the Act, as the most appropriate and effective means of addressing the welfare effects associated with visibility impairment. Together, the two programs and associated control strategies should provide appropriate protection against the effects of PM on visibility and enable all regions of the country to make reasonable progress toward the national visibility goal.

2. *Materials damage and soiling effects.* Annual and 24-hour secondary standards for materials damage and soiling effects of PM were established in 1987 at levels equal in all respects to the primary standards. As discussed in the Criteria Document and Staff Paper, particles affect materials by promoting and accelerating the corrosion of metals, by degrading paints, and by deteriorating building materials such as concrete and limestone. Soiling is found to reduce the aesthetic quality of buildings and objects of historical or social interest. Past studies have found that residential properties in highly polluted areas typically have lower values than those in less polluted areas. Thus, at high enough concentrations, particles become a nuisance and result in increased cost and decreased enjoyment of the environment.

In the proposal, EPA proposed to establish secondary standards for PM₁₀ and PM_{2.5} identical to the suite of proposed primary standards. Several comments recommended setting secondary standards at levels more stringent than the proposed primary standards in order to address various welfare effects of PM, including soiling and materials damage, acid deposition, and visibility. Some commenters specifically suggested changing the form or level of the proposed 24-hour, 98th percentile PM standards to better protect against elevated PM episodes and associated soiling, materials damage, and visibility effects.

After reviewing the extent of relevant studies and other information provided since the 1987 review of the PM standards, the Administrator concurs with staff and CASAC conclusions that the available data do not provide a sufficient basis for establishing a separate secondary standard based on soiling or materials damage alone. In the Administrator's judgment, however, setting secondary standards identical to the suite of PM_{2.5} and PM₁₀ primary standards would provide increased protection against the effects of fine particles and retain an appropriate degree of control on coarse particles. Accordingly, the Administrator establishes the secondary standards for PM_{2.5}

identical to the suite of primary standards to protect against materials damage and soiling effects of PM.

B. *Decision on the Secondary Standards*

The Administrator establishes secondary standards identical to the suite of primary standards. In the Administrator's judgment, the establishment of these standards, in conjunction with implementation of a regional haze program, will provide appropriate protection against the welfare effects associated with particle pollution.

IV. Other Issues

Commenters have raised a number of legal and procedural issues that are discussed in this unit. These include:

(1) Whether EPA must give consideration to costs and similar factors in setting NAAQS.

(2) Whether EPA erred in its selection of a methodology for determining the level of a NAAQS that protects public health with an adequate margin of safety.

(3) Whether EPA committed a procedural error by not entering into the rulemaking docket underlying data from certain epidemiological studies.

(4) Whether the 1990 amendments to the Act preclude EPA from revising the PM NAAQS to establish a new PM_{2.5} indicator. Responses to other legal and procedural issues are included in the Response-to-Comments Document.

A. *Consideration of Costs*

For more than a quarter of a century, EPA has interpreted section 109 of the Act as precluding consideration of the economic costs or technical feasibility of implementing NAAQS in setting them. As indicated in the proposal, a number of judicial decisions have confirmed this interpretation. *Natural Resources Defense Council v. Administrator*, 902 F.2d 962, 972-973 (D.C. Cir. 1990)(PM NAAQS)("PM₁₀"), vacated, in part, dismissed, 921 F.2d 326 (D.C. Cir.), cert. denied, 498 U.S. 1075, and cert. denied, 498 U.S. 1082 (1991); *Natural Resources Defense Council v. EPA*, 824 F.2d 1146, 1157-1159 (D.C. Cir. 1987)(en banc)(CAA section 112 standards for vinyl chloride)("Vinyl Chloride"); *American Petroleum Institute v. Costle*, 665 F.2d 1176, 1185-1186 (D.C. Cir. 1981)(ozone NAAQS)("Ozone"), cert. denied, 455 U.S. 1034 (1982); *Lead Industries Ass'n v. EPA*, 647 F.2d 1130, 1148-1151 (D.C. Cir.)(lead NAAQS)(Lead Industries), cert. denied, 449 U.S. 1042 (1980).

Some commenters have argued that costs and similar factors should, nonetheless, be considered, both in this rulemaking and in the rulemaking on proposed revisions to the NAAQS for ozone. Although most of the commenters' arguments are inconsistent with the judicial decisions cited in this unit, several commenters have argued that those decisions

are not dispositive. For reasons discussed in this unit and in the Response-to-Comments Document, EPA disagrees with these comments and maintains its longstanding interpretation of the Act as precluding consideration of costs and similar factors in setting NAAQS.

1. *Background.* Given the nature of the points raised, a brief review of the issue seems useful before addressing the comments. The requirement that EPA establish national ambient air quality standards for certain pollutants, to be implemented by the States, was enacted in 1970 as part of a set of comprehensive amendments that established the basic framework for Federal, State, and local air pollution control. When EPA promulgated the original NAAQS in 1971, its first Administrator, William D. Ruckelshaus, concluded that costs and similar factors could not be considered in that decision.⁵⁵ This conclusion was not challenged in litigation on the original NAAQS. It has been confirmed since then, however, by every judicial decision that has considered the issue.

As discussed in this unit, EPA's interpretation rests primarily on the language, structure, and legislative history of the statutory scheme adopted in 1970. It is also supported by the judicial decisions cited in this unit, as well as by legislative developments since 1970 that reaffirm Congress' original approach to the issue.

Without cataloguing all relevant aspects of the 1970 amendments and their legislative history, several basic points should be noted. Under section 109(b) of the Act, NAAQS are to be "based on" the air quality criteria issued under section 108 of the Act. Under section 108(a)(2) of the Act, the kind of information EPA is required to include in criteria documents is limited to information about health and welfare effects "which may be expected from the presence of [a] pollutant in the ambient air * * * ." There is no mention of the costs or difficulty of implementing the NAAQS, nor of "effects" that might result from implementing the NAAQS (as opposed to effects of pollution in the air).⁵⁶ By contrast, Congress explicitly provided for consideration of costs and similar factors in decisions under other sections of the Act.⁵⁷ Moreover, States were permitted to consider economic and technological feasibility in developing plans

⁵⁵ 36 FR 8186, April 30, 1971. EPA has maintained this interpretation consistently since then.

⁵⁶ That consideration of such factors was not intended in NAAQS decisions is also supported by section 109(a)(1) of the Act. For pollutants for which air quality criteria had been issued prior to the 1970 amendments, that provision required EPA to propose NAAQS within 30 days after enactment and to take final action 90 days later. The criteria issued previously did not include information on costs and similar factors, and it would have been difficult if not impossible for EPA to supplement them in time to include meaningful consideration of such factors in NAAQS proposed 30 days after enactment.

⁵⁷ See, e.g., sections 110(e)(1), 111(a)(1), 231(b) of the 1970 Act; see also, e.g., sections 113(d)(4)(C)(ii), 125(a)(3), 202(a)(3)(C), 317 of the 1977 Act.

to implement the NAAQS to the extent such consideration did not interfere with meeting statutory deadlines for attainment of the standards.⁵⁸ Finally, the legislative history indicated that Congress had considered the issue and had deliberately chosen to mandate NAAQS that would protect health regardless of concerns about feasibility.⁵⁹

The first judicial decision on the issue came in the Lead Industries case. An industry petitioner argued that EPA should have considered economic and technological feasibility in allowing a "margin of safety" in setting primary standards for lead. Based on a detailed review of the language, structure, and legislative history of the statutory scheme, the U.S. Court of Appeals for the District of Columbia Circuit concluded that:

This argument is totally without merit. [The petitioner] is unable to point to anything in either the language of the Act or its legislative history that offers any support for its claim * * * . To the contrary, the statute and its legislative history make clear that economic considerations play no part in the promulgation of ambient air quality standards under section 109.

647 F.2d at 1148.

The Court cited a number of reasons for this conclusion. *Id.* at 1148–1150. Among other things, it noted the contrast between section 109(b) of the Act and other provisions in which Congress had explicitly provided for consideration of economic and technological feasibility, as well as the requirement that NAAQS be based on air quality criteria defined without reference to such factors. *Id.* at 1148–1149 and n.37. The Court also noted that, in developing plans to implement NAAQS, States may consider economic and technological feasibility only to the extent that this does not interfere with meeting the statutory deadlines for attainment of the standards; and that EPA may not consider such factors at all in deciding whether to approve State implementation plans. *Id.* at 1149 n.37 (citing *Union Electric Co. v. EPA*, 427 U.S. 246, 257–258, 266 (1976)).⁶⁰

As to the legislative history of the 1970 amendments, the Court observed that:

⁵⁸ *Union Electric Co. v. EPA*, 427 U.S. 246, 257–58 (1976).

⁵⁹ The Senate report on the 1970 amendments stated: "In the Committee discussions, considerable concern was expressed regarding the use of the concept of technical feasibility as the basis of ambient air standards. The Committee determined that (1) the health of people is more important than the question of whether the early achievement of ambient air quality standards protective of health is technically feasible; and, (2) the growth of pollution load in many areas, even with application of available technology, would still be deleterious to public health."

"Therefore, the Committee determined that existing sources of pollutants either should meet the standard of the law or be closed down * * * ."

S. Rep. No. 91–1196, at 2–3 (1970).

⁶⁰ These limitations would, of course, make little sense if such factors could be considered in setting the NAAQS themselves.

[T]he absence of any provision requiring consideration of these factors was no accident; it was the result of a deliberate decision by Congress to subordinate such concerns to the achievement of health goals.

Id. at 1149. Citing several leading Supreme Court decisions, as well as the Senate report quoted in this unit, the Court noted that Congress had intended a drastic change in approach toward the control of air pollution in the 1970 amendments and was well aware that sections 108–110 of the Act imposed requirements of a "technology-forcing" character. *Id.*⁶¹

The Court also noted that Congress had already acted, in further amendments adopted in 1977, to relieve some of the burdens imposed by the 1970 amendments. *Id.* at 1150 n.38. Observing that Congress had, however, declined to amend section 109(b) of the Act to provide for consideration of costs and similar factors as requested by industrial interests, *Id.* n.39, the Court concluded:

A policy choice such as this is one which only Congress, not the courts and not EPA, can make. Indeed, the debates on the [1970 amendments] indicate that Congress was quite conscious of this fact * * * .

* * * [I]f there is a problem with the economic or technological feasibility of the lead standards, [the petitioner], or any other party affected by the standards, must take its case to Congress, the only institution with the authority to remedy the problem.

Id. at 1150.

After the decision in Lead Industries, Supreme Court review was sought on the question whether costs and similar factors could be considered in setting NAAQS, among other issues. The Supreme Court declined to review the decision. *Lead Industries Ass'n v. EPA*, 449 U.S. 1042 (1980). The subsequent decisions in Ozone, Vinyl Chloride, and PM₁₀, cited in this unit, strongly reaffirmed the interpretation adopted in Lead Industries.⁶² Supreme Court review of the Ozone and PM₁₀ decisions was sought but denied. *American Petroleum Institute v. Gorsuch*, 455 U.S. 1034 (1984); *American Iron and Steel Institute v. EPA*, 498 U.S. 1082 (1991).

⁶¹ Such requirements "are expressly designed to force regulated sources to develop pollution control devices that might at the time appear to be economically or technologically infeasible." *Id.* (quoting *Union Electric Co. v. EPA*, 427 U.S. at 257).

⁶² In the PM₁₀ case, for example, the Court considered an argument that EPA should have considered potential health consequences of unemployment that might result from revision of the primary NAAQS for PM:

"This claim is entirely without merit. In three previous cases, this court has emphatically stated that § 109 does not permit EPA to consider such costs in promulgating national ambient air quality standards * * * . It is only health effects relating to pollutants in the air that EPA may consider * * * . Consideration of costs associated with alleged health risks from unemployment would be flatly inconsistent with the statute, legislative history and case law on this point."

902 F.2d at 973 (emphasis in original; citations omitted).

The Lead Industries opinion focused largely, though not exclusively, on the 1970 amendments and their legislative history. Perhaps as a result, it did not canvass all the factors that, in fact, supported its conclusions at the time. For example, when Congress enacted major amendments to the Act in 1977, it was clearly aware that some areas of the country had experienced difficulty in attempting to attain some of the NAAQS.⁶³ It was also aware that there might be no health-effects thresholds for the pollutants involved, and that significant uncertainties are inherent in setting health-based standards under the Act.⁶⁴ In response, Congress made significant changes in the provisions for implementation of the NAAQS, including changes intended to ease the burdens of attainment. It also amended sections 108 and 109 of the Act in several ways; for example, by requiring periodic review and, if appropriate, revision of air quality criteria and NAAQS and by establishing a special scientific advisory committee (CASAC) to advise EPA on such reviews. Notably, Congress recognized that implementation of NAAQS could cause "adverse public health, welfare, social, economic, or energy effects" and charged CASAC with advising EPA on such matters.⁶⁵ Yet it made no changes in section 109(b) or section 108(a)(2) of the Act; that is, in the substantive criteria for setting or revising NAAQS. In other words, Congress chose to address economic and other difficulties associated with attainment of the NAAQS by adjusting the scheme for their implementation, rather than by changing the instructions for setting them.⁶⁶

Congress enacted major amendments to the Act again in 1990, well after the Lead Industries and Ozone decisions that interpreted section 109 of the Act as precluding consideration of costs in NAAQS

decisions.⁶⁷ In doing so, Congress was clearly aware of intervening developments such as EPA's decision to revise the PM NAAQS in 1987—the result of an elaborate review in which the Administrator strongly underscored the scientific uncertainties involved⁶⁸—and the Vinyl Chloride case drawing a sharp distinction between sections 109 and 112 of the Act with regard to consideration of costs and similar factors.⁶⁹ Indeed, the legislative history of the 1990 amendments reflects Congress' understanding that primary NAAQS were to be based on protection of health "without regard to the economic or technical feasibility of attainment."⁷⁰ Again, however, Congress chose to respond to severe, widespread, and persistent problems with attaining the NAAQS by adjusting the scheme for their implementation rather than by changing the basis for setting them. See, e.g., sections 181–192 of the Act.

2. *Public comments.* As noted previously, a number of commenters have argued that costs and similar factors should be considered in EPA's final decisions on revision of both the particulate and ozone NAAQS. Aside from arguments that are simply inconsistent with the judicial decisions cited in this unit, some of the commenters argue that those decisions are not dispositive for a variety of reasons. One commenter submitted a particularly comprehensive version of this argument; the following discussion focuses

⁶⁷ In the interim, the National Commission on Air Quality had also submitted its report to Congress as required by a provision of the 1977 amendments. Among other things, the Commission recommended that the statutory approach of requiring NAAQS to be set at levels necessary to protect public health, without consideration of economic factors, be continued without change. National Commission on Air Quality, *To Breathe Clean Air* 55 (1981).

⁶⁸ As the Administrator indicated in EPA's proposal to revise the PM standards:

"[T]hat review has revealed a highly limited data base—particularly where quantitative studies are concerned—and a wide range of views among qualified professionals about the exact pollution levels at which health effects are likely to occur. The setting of an 'adequate margin of safety' below these levels calls for a further judgment—in an area for which the scientific data base is even more sparse and uncertain * * *."

"* * * [L]ong and expert review of public health issues has to date revealed no scientific method of assessing exactly what level of standards public health requires. The scientific review indicates substantial uncertainties concerning the health risks associated with lower levels of particulate matter." (49 FR 10408, 10409, March 20, 1984)

⁶⁹ Congress was clearly aware of the 1987 decision to revise the PM NAAQS, which among other things involved changing the indicator for particulate matter from "total suspended particulate" to PM₁₀, because it enacted special nonattainment provisions, as well as provisions for PSD increments, applicable to PM₁₀. Sections 188–190 of the Act; section 166(f) of the Act. It was clearly aware of the Vinyl Chloride decision because it amended section 112 of the Act in response to that decision, essentially creating a new scheme for setting emission standards for hazardous pollutants.

⁷⁰ H.R. Rep. No. 101–490, pt. 1, at 145 (1990). See also S. Rep. No. 101–228, at 5 (1989).

primarily on points raised by that commenter, among others.⁷¹

As a general matter, the commenter acknowledges that Congress intended to preclude consideration of economic costs and similar factors in setting NAAQS. The commenter argues, however, that this is so only when the scientific basis for NAAQS is "clear and compelling" or "unambiguous." From that premise, the commenter advances three key assertions:

a. Where non-threshold pollutants are involved and the health evidence is ambiguous, section 109 of the Act must be interpreted to allow consideration of all relevant factors, including the practical consequences of EPA's decisions.

b. To the extent the judicial decisions cited in this unit are read as precluding this, they rest on a faulty analysis that pre-dates and cannot survive scrutiny under *Chevron, U.S.A. v. Natural Resources Defense Council*, 467 U.S. 837 (1984).⁷²

c. Because EPA has discretion to consider costs and similar factors where the health evidence is ambiguous, it must do so in light of Executive Order 12866 (58 FR 51735, October 4, 1993), and two recent statutes, the Unfunded Mandate Reform Act of 1995, 2 U.S.C. 1501–1571 (UMRA), and the Small Business Regulatory Enforcement Fairness Act of 1996, Pub. L. 104–121, 110 Stat. 857 (SBREFA), which in part amended the Regulatory Flexibility Act, 5 U.S.C. 601–808.

EPA believes all three assertions are clearly incorrect. Regarding the first point, it should be evident, both from previous NAAQS decisions and from the court opinions upholding them, that the scientific basis for NAAQS decisions has never pointed clearly and unambiguously to a single "right answer."⁷³ This is inherent in the statutory scheme for the establishment and revision of NAAQS, which in effect requires them to be based on the "latest scientific knowledge" on potential health and welfare effects of the

⁷¹ Additional responses to points raised by this commenter and others are included, as appropriate, in the Response-to-Comments Document.

⁷² Several other commenters argue that the cited decisions are not dispositive because they held only that EPA is not required to consider costs and similar factors in setting NAAQS. As discussed in this unit in connection with *Chevron*, however, the decisions clearly concluded that Congress intended to preclude consideration of such factors, and that EPA is not free to alter that congressional choice. Although these conclusions are technically dicta, nothing in the Court's opinions suggests that it would have interpreted section 109 of the Act differently had EPA claimed authority to consider costs and similar factors in NAAQS decisions. Indeed, the tone of the opinions argues to the contrary. See, e.g., PM₁₀, 902 F.2d at 973. Cf. *Ethyl Corp. v. EPA*, 51 F.3d 1053 (D.C. Cir. 1995).

⁷³ See, e.g., *Lead Industries*, 647 F.2d at 1146–1147, 1153–1156, 1160–1161, 1167 n.106. In enacting the 1970 amendments, Congress was aware that there were gaps in the scientific information available then as a basis for establishing the original NAAQS. See, e.g., S. Rep. No. 91-1196, at 9–11 (1970). If anything, Congress had an even greater understanding of the point when it enacted the 1977 amendments without changing the substantive criteria for setting NAAQS. See H.R. Rep. No. 95-294, at 43–51, 181–182 (1977).

pollutant in question. See sections 109(b) and 108(a)(2) of the Act. Although advances in science increase our understanding of such effects, they also raise new questions. For this reason, the key studies for any given decision on revision of a NAAQS are, almost by definition, "at the very 'frontiers of scientific knowledge.'" ⁷³ That is, studies that call into question the adequacy of a standard are always those that go beyond previous studies—by reporting new kinds of effects, for example, or effects at lower concentrations than those at which effects have been reported previously.

As with pioneering work in other fields, such studies may have a variety of strengths and limitations. ⁸⁷⁵ As a result, the validity and implications of such studies may be both uncertain and highly controversial. Given the precautionary nature of section 109 of the Act, ⁷⁶ however, it is precisely these kinds of studies that the Administrator must grapple with when advances in science suggest that revision of a NAAQS is appropriate.

As a result, the EPA staff typically recommends for consideration, and the Administrator may propose for comment, a range of alternatives based on what the commenter would call "ambiguous" science. In this respect, the current reviews of the NAAQS for ozone and particulate matter are not unusual and do not differ, for example, from the review that led to adoption of the PM₁₀ NAAQS in 1987. ⁷⁷ Indeed, the NAAQS that were upheld in the Lead Industries, Ozone, and PM₁₀ decisions were all based on highly controversial health evidence; the Lead Industries decision took note of congressional statements recognizing that there may be no thresholds for criteria pollutants; and the Ozone and PM₁₀ decisions noted the Administrator's findings that clear thresholds could not be identified for ozone and particulate matter, respectively. ⁷⁸ Thus, the present decisions on revision of the NAAQS for ozone and particulate matter cannot be distinguished from those past

decisions in terms of the nature of the health evidence or pollutants involved. ⁷⁸

Regarding the second of the commenter's key assertions, EPA determines it is clear that the judicial decisions cited in this unit were correctly decided and continue to be good law under Chevron. In Chevron, the Supreme Court essentially reaffirmed the principle that courts must defer to reasonable agency interpretations of the statutes they administer where Congress has delegated authority to them to elucidate particular statutory provisions. Where the intent of Congress on an issue is clear, however, it must be given effect by the agency and the courts. See 467 U.S. at 842–45. Thus, the first question on review of an agency's interpretation under Chevron is "whether Congress has directly spoken to the precise question at issue." If the court determines that it has not, the remaining question for the court is "whether the agency's answer is based on a permissible construction of the statute." 467 U.S. at 842–843 (footnote omitted). In determining whether Congress "had an intention on the precise question at issue," a court employs "traditional tools of statutory construction." *Id.* at 843 n.9. ⁸⁰

In essence, the commenter's argument here is that the Lead Industries decision did not address whether Congress had "spoken directly" to the precise issue posed by the commenter; that is, whether section 109 of the Act must be interpreted differently for NAAQS decisions involving non-threshold pollutants and "ambiguous" health evidence. The Lead Industries opinion, which pre-dated Chevron, did not pose the question in those terms. Its focus, however, was clearly on what Congress intended to be the basis for NAAQS decisions, in a context the Court understood to involve considerable uncertainty and debate about the health evidence, as well as the possibility that there was no threshold for health effects of the pollutant. ⁸¹ In short, the health evidence was hardly "unambiguous," yet the Court interpreted section 109 of this Act as precluding consideration of costs and similar factors even in allowing a margin of safety. Nothing in the Lead Industries decision or in the subsequent cases suggests in any way that section 109 of the Act should be interpreted differently based on the nature of the pollutants or health evidence involved, and the Court's findings on congressional intent admit of no exceptions:

⁷⁹ Indeed, the present decisions on the NAAQS for PM and ozone are based on some of the best scientific information the Agency has ever been able to rely on in NAAQS decision-making. In particular, the science underlying these decisions is much more extensive and of much better quality than the science underlying the existing NAAQS for PM and ozone.

⁸⁰ In practice, analysis of this question is sometimes referred to as a "Chevron step one" analysis.

⁸¹ See, e.g., 647 F.2d at 1148–51, 1152–53 and n.43, 1160–61.

* * * [T]he statute and its legislative history make clear that economic considerations play no part in the promulgation of ambient air quality standards under Section 109.

647 F.2d at 1148.

Alternatively, the commenter argues that the Lead Industries case decided the issue incorrectly in light of the principles announced subsequently in Chevron. In this context, the commenter essentially argues that the Lead Industries decision rested on two factors that are no longer probative:

- (1) That there was no indication that Congress meant to allow consideration of costs in NAAQS decisions, and
- (2) That Congress specifically provided for such consideration in other sections of the Act but not in section 109.

On the first point, the commenter argues that EPA is free under Chevron to consider costs and similar factors (by reinterpreting section 109 of the Act) unless there is evidence that Congress intended to restrict its discretion. As to the second point, the commenter argues that similar reasoning was rejected in Vinyl Chloride.

In Vinyl Chloride, however, an en banc decision that post-dated Chevron, the Court essentially underscored the point that such issues cannot be decided mechanically but must turn, instead, on more analytical attention to relevant indicia of congressional intent. See, e.g., 824 F.2d at 1157 n.4; *Id.* at 1157–1163. With reference to NAAQS decisions in particular, the Court concluded that there were concrete indications of congressional intent to preclude consideration of costs and similar factors; for example, the fact that section 108 of the Act "enumerate[s] specific factors to consider and pointedly exclude[s] feasibility." 824 F.2d at 1159. In a later case, moreover, the same Court held that EPA could not consider certain factors, in decisions under section 211(f)(4) of the Act, for reasons exactly parallel to those that the commenter criticizes in Lead Industries. See *Ethyl Corp. v. EPA*, 51 F.3d 1053, 1057–1063 (D.C. Cir. 1995).

Beyond this, the commenter's characterization of the Lead Industries decision ignores or discounts much of the key evidence cited by the Court, including the language, structure, and legislative history of the statutory scheme established in 1970, for its conclusion that Congress intended to preclude consideration of costs and similar factors in NAAQS decisions. ⁸² As indicated

⁸² See 647 F.2d at 1148–51. By contrast, the commenter's argument that Congress actually intended EPA to consider such factors relies heavily on statements made in subsequent legislative history, most of which were made in floor debate, that sought to justify controversial amendments to establish a different program than the NAAQS and did not involve any proposed changes in section 109 of the Act or related provisions; and statements in early judicial decisions involving programs under other statutory provisions. In context, EPA determines these and other statements cited by the commenter are consistent with and do not alter the conclusion that Congress intended to preclude consideration of costs and similar factors under section 109 of the Act.

⁷⁴ Lead Industries, 647 F.2d at 1147 (quoting *Ethyl Corp. v. EPA*, 541 F.2d 1, 24–27 (D.C. Cir.) (en banc), cert. denied, 426 U.S. 941 (1976)).

⁷⁵ They may have methodological flaws, for example, but nonetheless report effects that are of serious medical significance; or they may be of impeccable quality but involve effects of uncertain significance. Others may involve results that are striking but hard to explain in terms of previous knowledge, or results that seem plausible and important but are not yet replicated by other studies.

⁷⁶ See, e.g., Lead Industries, 647 F.2d at 1155–1156; H.R. Rep. No. 94-295, at 43–51 (1977).

⁷⁷ As previously discussed, the Administrator strongly emphasized the uncertainties involved in that review. As a result of the uncertainties, he proposed "relatively broad" ranges for comment, though he focused on lower levels within the ranges as providing greater margins of safety against the health risks involved. See 49 FR 10408, 10409, March 20, 1984.

⁷⁸ See, e.g., Lead Industries, 647 F.2d at 1152–53 and n.43, 1159–60; Ozone, 665 F.2d at 1185, 1187; PM₁₀, 902 F.2d at 969–71, 972.

in this unit, the Vinyl Chloride and PM₁₀ cases, both of which post-dated Chevron, reached the same conclusion.

Moreover, this series of decisions went far beyond mere deference to an agency interpretation. As indicated in the Vinyl Chloride case, the Lead Industries court found "clear evidence" of Congressional intent, which was to limit the factors EPA may consider under section 109 of the Act. 824 F.2d 1159. Consistent with Chevron, these findings were based on traditional tools of statutory construction. See *Id.* at 1157-1159; Lead Industries, 647 F.2d at 1148-1151. In terms of the analytical framework later established by Chevron, these were Chevron step one findings, meaning that the statute spoke directly to the issue and that the courts, as well as the agency, must give effect to Congress' intent as so ascertained. See 467 U.S. at 842-843.⁸³ Thus, absent a more recent legislative enactment overriding that intent, EPA has no discretion to alter its longstanding interpretation that consideration of costs and similar factors is precluded in NAAQS decisions under section 109 of the Act.⁸⁴

As to the commenter's third key assertion, Executive Order 12866, UMRA sections 202 and 205, and the Regulatory Flexibility Act (RFA), as amended by SBREFA, do not conflict with this interpretation or require a different result. Basically, the commenter argues that the Executive Order, UMRA, and the RFA (as amended by SBREFA) require

⁸³ The commenter argues that the post-Chevron cases accepted the Lead Industries analysis uncritically rather than re-examining it under Chevron. Clearly, this elevates form over substance. It is true that neither case referred to Chevron in discussing the point at issue. In Vinyl Chloride, however, the Court retraced the steps in the Lead Industries analysis in some detail, characterized some of the key evidence reviewed in that analysis in terms going beyond mere rote repetition (e.g., "a far clearer statement than anything in the present case that Congress considered the alternatives"), and used Chevron-like language in discussing the significance of that evidence; that is, that it demonstrated congressional intention on the point at issue. E.g., 824 F.2d at 1159. Given that the Vinyl Chloride case was decided three years after Chevron, that it was an en banc decision of the D.C. Circuit involving interpretation of statutory language very similar to that in Lead Industries, and that the Court cited Chevron twice in analyzing the language and history of section 112 of the Act, it seems highly unlikely that the Court was unmindful of Chevron principles in concluding that Congress intended to preclude consideration of costs under section 109 of the Act but not under section 112 of the Act.

In the PM₁₀ decision, the Court confirmed the sharp distinction it had drawn, based on such evidence of congressional intent, between sections 109 and 112 of the Act in Vinyl Chloride. 902 F.2d at 972-973. Although discussion of the point was brief and did not mention Chevron, the industry petitioner raising the point had cited Chevron in arguing that the Lead Industries interpretation was not binding, and that EPA's decision on the PM₁₀ standards should be reversed on the ground that it rested on a legal position that EPA unjustifiably believed was mandated by Congress. Reply Brief of the American Iron and Steel Institute at 11 and n.10, *Natural Resources Defense Council v. Administrator*, 902 F.2d 962 (D.C. Cir. 1990) (Nos. 87-1438 et al.). Thus, Chevron issues were properly before the Court and were brought squarely to its attention.

⁸⁴ See also 52 FR 24854, July 1, 1987.

agencies to use cost (or similar factors) as a decisional criterion in making regulatory decisions, and that this modifies the Clean Air Act's directive that EPA is precluded from considering costs when setting a NAAQS. The commenter's argument is flawed on a number of grounds. First, UMRA and the RFA (as amended by SBREFA) do not conflict with section 109 of the Act because they do not apply to this decision, as discussed in Unit VIII. of this preamble. Second, the Executive Order and both statutes are quite clear that they do not override the substantive provisions in an authorizing statute. Third, the commenter's premise that UMRA and the RFA (as amended by SBREFA) establish substantive decisional criteria that agencies are required to follow is wrong.

As a matter of law, the Executive Order cannot (and does not purport to) override the Clean Air Act. The Executive Order does not conflict with section 109 of the Act because the requirement that agencies "select approaches that maximize net benefits" does not apply if a "statute requires another regulatory approach." Executive Order 12866, section (1)(a), (58 FR 51735, October 4, 1993). More generally, the Executive Order provides that agencies are to adhere to its regulatory principles only "to the extent permitted by law." *Id.*, section (1)(b).

UMRA sections 202 and 205 do not apply to this decision, as discussed in Unit VIII. of this preamble. Even when they do apply to a regulatory action, they do not establish decisional criteria that an agency must follow, much less override decisional criteria established in the statute authorizing the regulatory action. UMRA does not require an agency to select any particular alternative. Rather, an agency can select an alternative that is not the least costly, most cost-effective or least burdensome if the agency explains why. Section 205(b)(1) of UMRA. Such an explanation is not required if the least costly, most cost-effective or least burdensome alternative would have been "inconsistent with law," section 205(b)(2) of UMRA, and the only alternatives that an agency should consider are ones that "achieve[] the objectives of the rule," section 205(a) of UMRA. The UMRA Conference Report confirms that UMRA does not override the authorizing statute. "This section [202] does not require the preparation of any estimate or analysis if the agency is prohibited by law from considering the estimate or analysis in adopting the rule." 141 Cong. Rec. H3063 (daily ed. March 13, 1995).

The RFA (as amended by SBREFA) also does not apply to this decision, as discussed in Unit VIII. of this preamble. As is the case with UMRA, even when the RFA (as amended by SBREFA) does apply to a regulatory action, it does not establish decisional criteria that an agency must follow, much less override the underlying substantive statute. When the RFA was adopted in 1980,

Congress made clear that it did not alter the substantive standards contained in authorizing statutes: "The requirements of section 603 and 604 of this title [to prepare initial and final regulatory flexibility analyses] do not alter in any manner standards otherwise applicable by law to agency action." Section 606 of the RFA. The legislative history further explains that section 606 "succinctly states that this bill does not alter the substantive standard contained in underlying statutes which defines the agency's mandate."⁸⁵ When Congress passed SBREFA in 1996 and amended parts of the RFA, it did not amend section 606.

Even when a regulatory decision is subject to sections 603 and 604 of the RFA and an agency is therefore required to analyze alternatives that minimize significant economic impacts on small entities, the RFA (as amended by SBREFA) does not establish decisional criteria that an agency is required to follow. Both section 603 and 604 of the RFA provide that the alternatives an agency should consider are to be "consistent with the stated objectives of applicable statutes." Section 603(c) and 604(a)(5) of the RFA. Furthermore, although the RFA (as amended by SBREFA) requires agencies to consider alternatives that minimize impacts on small entities subject to the rules' requirements and to explain their choice of regulatory alternatives, it does not require agencies to select such alternatives. For these reasons, the RFA (as amended by SBREFA) does not conflict with or override the Clean Air Act's preclusion of considering costs and similar factors in setting NAAQS.

3. *Conclusion.* In summary, EPA determines that the judicial decisions cited in this unit are both correct and dispositive on the question of considering costs in setting NAAQS, and that the Agency is not free to reinterpret the Act on that question.

B. Margin of Safety

Several commenters questioned the approach used by the Administrator in specifying PM standards that protect public health with an adequate margin of safety. Rather than the integrative approach applied by the Administrator, these commenters maintained that EPA must employ a two-step process. One line of argument was that the Administrator must first determine a "safe level" and then apply a margin of safety taking into account costs and societal impacts. It was argued that this was the only approach that would enable the Administrator to reach a reasoned decision on a standard level that protects public health against unacceptable risk of harm, such that any remaining risk was "acceptable." In effect, these commenters adopted the two-step methodology endorsed by Vinyl Chloride,

⁸⁵ 126 Cong. Rec. 21452, 21455 (1980) (Description of Major Issues and Section-By-Section Analysis of Substitute for S. 299).

824 F.2d 1146, for setting hazardous air pollutant standards under section 112 of the Act. Another commenter also maintained that the Administrator must apply a two-step process but from a different perspective. It was argued that EPA should first identify the lowest observed effect level and then apply a margin of safety to address uncertainties and to protect the most sensitive individuals within the at-risk population(s). This commenter also maintained that the use of risk assessment in establishing a NAAQS was a departure from past practice, and that this departure was not adequately explained.

In recognition of the complexities facing the Administrator in determining a standard that protects public health with an adequate margin of safety, the courts have declined to impose any specific requirements on the Administrator's methodological approach. Thus, in *Lead Industries* the court held that the selection of any particular approach to providing an adequate margin of safety "is a policy choice of the type Congress specifically left to the Administrator's judgment. This court must allow him the discretion to determine which approach will best fulfill the goals of the Act." 647 F.2d at 1161-1162. As a result, the Administrator is not limited to any single approach to determining an adequate margin of safety and, in the exercise of her judgment, may choose an integrative approach, a two-step approach, or perhaps some other approach, depending on the particular circumstances confronting her in a given NAAQS review.

With respect to the approaches advanced in comment, the PM₁₀ case made clear that the two-step process endorsed in *Vinyl Chloride* was necessary because of the need under section 112 of the Act to "sever determinations that must be based solely on health considerations from those that may include economic and technical considerations." 902 F.2d at 973. Because the Administrator may not consider cost and technological feasibility under section 109 of the Act, however, the Court concluded that "the rationale for parsing the Administrator's determination into two steps is inapposite." *Id.*

The claim that EPA must follow a two-step process of first identifying the lowest observed effects level and then applying a margin of safety has also been rejected by the courts. In *Lead Industries*, the Court specifically held that the Administrator need not apply a margin of safety at the end of the analytical process but may take into account margin of safety considerations throughout the process as long as such considerations are fully explained and supported by the record. 647 F.2d 1161-1162. *Accord*, PM₁₀, 902 F.2d at 973-974.

Because such factors as the nature and severity of the health effects involved, the size of the sensitive population(s) at risk, the types of health information available, and the kind and degree of uncertainties that must be

addressed will vary from one pollutant to another, the most appropriate approach to establishing a NAAQS with an adequate margin of safety may be different for each standard under review. Thus, no generalized paradigm such as that imbedded in EPA's cancer risk policy can substitute for the Administrator's careful and reasoned assessment of all relevant health factors in reaching such a judgment. As noted in this unit, both Congress and the courts have left to the Administrator's discretion the choice of analytical approaches and tools, including risk assessments, rather than prescribing a particular formula for reaching such determinations.⁸⁶ Because of the inherent uncertainties that the Administrator must address in margin of safety determinations, they are largely judgmental in nature, particularly with respect to non-threshold pollutants, and may not be amenable to quantification in terms of what risk is "acceptable" or any other metric. In view of these considerations, the task of the Administrator is to select an approach that best takes into account the nature of the health effects and other information assessed in the air quality criteria for the pollutant in question and to apply appropriate and reasoned analysis to ensure that scientific uncertainties are taken into account in an appropriate manner.

In this instance, the Administrator has clearly articulated the factors she has considered, the judgments she has had to make in the face of uncertain and incomplete information, and alternative views as to how such information should be interpreted, in reaching her decision on standard specifications that will protect public health with an adequate margin of safety. See Unit II. of this preamble. Her conclusions on these matters are fully supported by the record.

C. Data Availability

Several commenters questioned EPA's ability to rely on studies demonstrating an association between PM and excess mortality without obtaining and disclosing the raw "data" underlying these studies for public review and comment. In particular, a number of commenters cited Dockery, D.W., et al. 1993 and Pope, C.A. III, et al., 1995, as studies upon which EPA relied without obtaining and disclosing the underlying raw data. One commenter also cited J. Schwartz et al., 1996 in the same context.⁸⁷ According

⁸⁶ Contrary to one of the comments received, EPA's use of risk assessment in this rulemaking is by no means a departure from past practice. The EPA first considered and began applying risk assessment methods in the late 1970's (44 FR 8210, 8211, February 8, 1979).

⁸⁷ Contrary to this commenter's assertion, both the health and air quality data used in the 1996 Schwartz study are available to interested parties. EPA's Office of Research and Development maintains a copy of the air pollution database used in the Schwartz study and it has previously been made available in response to Freedom of Information Act requests from interested parties, such as the American Iron and Steel Institute (AISI). The Harvard

to the commenters, without the underlying data used in these studies, the reliability of these studies cannot be assessed accurately. These commenters requested that EPA obtain the relevant data and make it available for public review. In light of the court-ordered requirement that EPA publish its rule by July 19, 1997, the commenters argued that EPA must retain the current PM₁₀ NAAQS pending additional review of the raw data and the studies at issue. One commenter, the American Petroleum Institute (API) requested that EPA remove the studies from the docket, unless the underlying data was also included in the docket.⁸⁸

A few commenters argued that section 307(d) of the Act requires that EPA obtain the raw data underlying these studies and that a failure to do so contradicts the plain language of section 307(d)(3) of the Act, which requires EPA to place in the docket any "factual data on which the proposed rule is based." Other commenters argued that under section 307(d)(8) of the Act, a failure to obtain and disclose the underlying raw data used in the studies would constitute an error "so serious and related to matters of such central relevance to the rule that there is a substantial likelihood that the rule would have been significantly changed if such errors had not been made." *Id.* According to one commenter, without the raw data and an opportunity for an analysis of it, "EPA has no legal alternative other than to conclude that no new air quality standard would be appropriate within the meaning of CAA section 109(a)(1)(B)." Finally, a number of commenters have argued that recent caselaw under the Clean Air Act and other statutes makes clear that EPA has a legal obligation to obtain and disclose the data used in these studies.⁸⁹

In developing the proposed revisions to the PM NAAQS, the Administrator relied on the scientific studies cited in the rulemaking record, rather than on the raw data underlying

School of Public Health has also made this data available to several collaborators and to the Health Effects Institute. With regard to the health data underlying the Schwartz study, that mortality data was compiled by the National Center for Health Statistics (NCHS) and can be purchased from the NCHS by interested parties. Thus, there is no real data availability concern with regard to the 1996 Schwartz study. However, even were this not the case, for the reasons discussed more fully in this unit and elsewhere in the preamble, EPA believes it would be entitled to rely upon this study and other studies, including the Dockery and Pope studies, regardless of the availability of the underlying health data.

⁸⁸ API's letter stated that "API petitions EPA to identify all studies that rely, in any way, on data not available for public review as part of the rulemaking process and remove those studies from the record." To the extent this letter constitutes a "petition" for EPA action, EPA hereby denies the "petition" for the reasons stated in this unit and elsewhere in this preamble.

⁸⁹ One commenter argued that the failure to obtain and disclose the underlying data was a violation of the Administrative Procedure Act (APA). The NAAQS rulemaking is promulgated under section 307(d) of the Act; the APA generally does not apply to such rulemakings. See section 307(d)(1) of the Act.

them.⁹⁰ In this case, the raw data consists of responses to health questionnaires based on information supplied by individual citizens, or computer tabulations of this information, which remains confidential, and air quality and monitoring data, most of which is now publicly available. EPA does not generally undertake evaluations of raw, unanalyzed scientific data as part of its public health standard setting process. Only in extreme cases—for example where there are credible allegations of fraud, abuse or misconduct—would a review of raw data be warranted. It would be impractical and unnecessary for EPA to review underlying data for every study upon which it relies as support for every proposed rule or standard. If EPA and other governmental agencies could not rely on published studies without conducting an independent analysis of the enormous volume of raw data underlying them, then much plainly relevant scientific information would become unavailable to EPA for use in setting standards to protect public health and the environment. In addition, such data are often the property of scientific investigators and are often not readily available because of the proprietary interests of the investigators or because of arrangements made to maintain confidentiality regarding personal health status and lifestyle information of individuals included in such data. Without provisions of confidentiality, the possibility of conducting such studies could be severely compromised.⁹¹

⁹⁰ It is important to note that while EPA did use the Dockery and Pope studies to confirm its conclusions regarding the health effects of fine particulate air pollution and thus as support for its decision to revise the PM standard, these studies do not provide the sole (or even primary) basis for EPA's decision regarding PM_{2.5}, despite the assertions of numerous commenters. The proposed standards are based on a consideration of a large body of epidemiological studies, a clear majority of which suggest PM is strongly linked to mortality and other serious health effects at concentrations permitted under the current standards. Although the specific levels of the PM_{2.5} standards are based on a more limited number of studies that actually measured fine particles and/or components of fine particles, the Dockery and Pope studies were not used in initially selecting the annual fine particle standard level, which was principally based on examination of other daily mortality and respiratory effects studies (Koman, 1996, 1997) that found significant associations between fine PM and effects in cities with annual average PM_{2.5} concentrations of about 16 to 21 µg/m³. Only then were the long-term Dockery and Pope studies examined and used to help corroborate this result; in the opinion of the Administrator, neither study alone (or together) provided sufficient evidence to support more stringent levels below those identified from the daily studies. Thus, removal of the Dockery and Pope studies would not affect the conclusions about the significance of the risks and therefore, while these long-term studies tend to strengthen the need for fine particle control and provide important insights into the nature of PM effects, removal of these two studies from consideration would not have changed the selected standard level.

⁹¹ Some commenters noted that with regard to the health data underlying the 1993 Dockery and 1995 Pope studies, since EPA provided partial funding for these studies, EPA has access to this data and cannot shield itself from the duty to obtain this data by claiming that it is not in its possession. Although a legal argument potentially exists that EPA may obtain access to such data, this legal

argument has not been tested in the courts. More importantly, EPA's ability to rely on studies without reviewing the raw data should not depend on whether some Agency of the Federal government funded the science.

In this case, the merits of the studies considered and used in developing the PM_{2.5} standard have been discussed and debated extensively over the past several years, both as part of the EPA review of the pertinent science and in a number of other public forums. The studies at issue were critically evaluated by the Agency's Office of Research and Development (ORD) and by the EPA's independent Clean Air Scientific Advisory Committee (CASAC), in a multi-year process for assessment of the science at issue. As with other studies on which EPA relied, particular attention was given to the strengths and limitations of the Dockery, Schwartz and Pope studies during this process, which involved numerous opportunities for public participation and extensive input from interested parties. The results of these studies are not only consistent with each other, but they are also consistent with the results of other studies demonstrating significant associations between long-term exposure to fine particle indicators and mortality. See U.S. EPA, 1996b, p. V-62. The CASAC concluded that EPA's assessments of the pertinent science properly characterized both the current state of knowledge and the range of policy options for revising the standards.

In fact, many peer reviewed studies have reported associations between PM and premature death; the Dockery, Schwartz and Pope studies are among the most recent studies to corroborate this association. In the early 1990s, several studies were published showing associations at levels below the current PM standards. Some critics began raising questions about the extent to which the results could be reproduced and the unavailability of underlying data. In response, an independent group of investigators under the auspices of the Health Effects Institute (HEI), a highly respected research organization jointly funded by EPA and several motor vehicle manufacturers, undertook a reanalysis of several such studies. The original investigators of several studies, including studies conducted at Harvard University, Brigham Young University, and the San Francisco Bay Area Air Quality Management District provided their raw air quality data sets to the HEI investigation team for reanalysis. HEI's reanalysis produced numerical results from the data sets for all six cities that closely agree with and, in general, confirm the results of the original investigators. Thus, as noted in Unit II. of this preamble, these reanalyses by respected independent scientists confirmed the reliability and reproducibility of prior work of the original investigators, including work by Dockery et al. (1992), Pope et al. (1992),

Schwartz and Dockery (1992a), and Schwartz (1993).

Thus, the 1993 Dockery and 1995 Pope studies build upon previous studies done by a number of different researchers and have been subject to an extensive peer review process by EPA's ORD, CASAC and HEI. They also underwent a peer review process at the time of their publication in reputable scientific journals. Given the consistency and coherence of the scientific evidence and the scrutiny the studies have received in peer review and in the extensive scientific review process described in this unit, EPA does not agree that review of the underlying data for these studies is also necessary. Considering the various reviews described in this unit and the fact that EPA has received no specific and substantiated reason, such as plausible allegations of fraud or scientific abuse, to doubt the overall validity of their conclusions, EPA agrees with CASAC that revision of the standard is appropriate, based on these and other studies.

In spite of EPA and CASAC's conclusion that it is appropriate to rely on the Pope, Dockery and other studies to establish a PM_{2.5} NAAQS, EPA also believes in public disclosure and supports efforts to seek appropriate release of data underlying the studies in question. On January 31, 1997, EPA wrote to the principal scientific investigators at the Harvard School of Public Health and at Brigham Young University and urged them to make the data associated with their studies available to interested parties. Studies conducted by these investigators relied on data compiled as part of the Harvard Six-Cities Study and data compiled by the American Cancer Society (ACS) as part of the Cancer Prevention Study II.

The studies in question combined health data on individuals with air pollution data. The air pollution data are publicly available. The health data consist of personal and confidential information, e.g. age, sex, weight, education level, smoking history, occupational exposures, medical history. These data are not publicly available. In compiling these data, researchers have promised study participants that private, personal information would be kept confidential under signed assurances of confidentiality. Data-sharing arrangements with outside parties must, therefore, accommodate interests both in making data accessible and in protecting the confidentiality of the information contained within them.

Both the Harvard School of Public Health and the American Cancer Society have made such arrangements. Both have processes which allow outside scientists, in collaboration with Harvard and ACS researchers, to access their databases for the conduct of legitimate scientific research. Scientists from all over the world have applied for and have been granted such access and numerous studies have been conducted and published using the databases.

Because of increased interest resulting from EPA's rulemaking on PM standards and at the request of the Harvard School of Public Health, HEI is taking additional steps to provide a forum for outside researchers to access health data associated with the Harvard-Six Cities Study and perhaps others. HEI has convened an expert panel of esteemed scientists to access underlying data and to conduct additional reanalyses. This arrangement appears to provide a constructive venue for testing legitimate scientific hypotheses while protecting the confidentiality of the underlying data.

Nevertheless, as noted previously, EPA has full confidence in the scientific integrity of the Dockery, Schwartz, and Pope studies and their suitability for use in the Agency's rulemaking on PM, without undertaking a separate or additional review and analysis of the underlying raw data. The decision to propose revisions of the current PM standards was based on careful assessment of the scientific and technical information presented in the PM Criteria Document and Staff Paper. The decision was also consistent with the consensus of CASAC that "although an understanding of health effects of PM is far from complete, the Staff Paper, when revised, will provide an adequate summary of our present understanding of the scientific basis for making regulatory decisions concerning PM standards." The extensive PM epidemiological data base provides evidence that serious adverse health effects, e.g., mortality, exacerbation of chronic disease, increased hospital admissions, respiratory symptoms, and pulmonary function decrements, in sensitive subpopulations, e.g., the elderly, individuals with cardiopulmonary disease and children, are attributable to PM at levels below the current standards. The increase in risk is significant from an overall public health perspective because of the large number of individuals in sensitive subpopulations that are exposed to ambient PM and the significance of the health effects. These considerations, as well as others discussed in the proposal and Staff Paper, such as the need to consider fine and coarse particles as distinct classes, led both the Administrator and CASAC to conclude that revision of the current standards is clearly appropriate. This conclusion remains unchanged despite the fact that EPA is without the actual raw and unanalyzed health data underlying the studies.

A number of commenters cited section 307(d) of the Act in support of their position that EPA is required to obtain and disclose the underlying raw data. Under section 307(d)(3) of the Act, EPA is required to issue a notice of proposed rulemaking in the **Federal Register** that is accompanied by a "statement of basis and purpose" that includes "a summary" of:

(A) The factual data on which the proposed rule is based.

(B) The methodology used in obtaining the data and in analyzing the data.

Thus, it is clear from the language of section 307(d) of the Act that where EPA relies on any "data" as support in its rulemakings under the Clean Air Act, it has an obligation to include such data or information in the rulemaking docket that is open to the public. Where EPA fails to do so and the error is "so serious and related to matters of such central relevance to the rule that there is a substantial likelihood that the rule would have been significantly changed if such errors had not been made," a reviewing court may overturn the rule.

In this case, as noted previously, EPA did not rely upon the raw health data supporting the Dockery and Pope studies; it relied instead upon the studies themselves. These studies may properly be considered "data." The EPA has never had the raw health data in its possession; thus EPA has neither reviewed it nor had an opportunity to place it in the docket. The EPA did rely on the studies and these studies are included in the docket and are available for public review. Because EPA neither reviewed nor relied upon the raw data, there is no obligation to obtain it or to make it available.

Some commenters argued that the language of section 307(d) of the Act, which refers to the "factual data" and which also discusses the "methodology used in obtaining and analyzing the data" distinguishes between raw data and studies. In the view of these and other commenters, the plain language of section 307(d) of the Act requires that EPA obtain and disclose the raw data used in the Dockery and Pope studies. According to these commenters, without such raw "data," EPA cannot legally promulgate its rule.

The EPA disagrees with this narrow interpretation of the word "data" and of section 307(d) of the Act. Data can take many forms, including studies, reports, tabulations, graphs and summaries, as well as more raw forms, such as questionnaire responses, test results and even actual physical specimens. The "factual data" called for by section 307(d) of the Act may clearly include peer-reviewed scientific studies. Nor does section 307(d) of the Act prohibit EPA from relying on a study for standard setting without obtaining the raw, underlying data supporting a study. Indeed, as noted in the legislative history to section 307(d) of the Act,

*** [t]he [House Commerce] Committee recognizes that the factual support needed for a rule may vary greatly according to the subject being addressed and that rules on some subjects, such as procedures, may not require any factual basis at all. There is no intention to increase the amount of 'factual' support now required to support 'policy judgments where no factual certainties exist or where facts alone do not provide the answer,' Industrial Union Department, *AFL-CIO v. Hodgson*, 499 F.2d 467, 476 (D.C. Cir. 1974). Nor is there any intent to diminish the Administrator's authority to adopt precautionary regulations based on a showing of risk ***.

H.R. Rep. No. 95-294, at 323 (1977) (footnote omitted). As this legislative history makes clear, the language in section 307(d) of the Act is not intended to require EPA to change the amount of "factual support" that EPA must assemble in order to promulgate a rule and EPA may adopt "precautionary" regulations "where no factual certainties exist." Given this clarification in the legislative history, it is evident that EPA is entitled under section 307(d) of the Act to rely on studies rather than raw data in developing its Clean Air Act rules, despite the arguably ambiguous use of the term "data."⁹²

Moreover, EPA has relied on studies in the past (including studies using the undisclosed Six Cities data) without obtaining or disclosing the underlying raw data, and EPA's reliance on such studies to set Clean Air Act standards has been upheld in court. In *NRDC v. EPA*, 902 F.2d 962 (D.C. Cir. 1990), the D.C. Circuit declined to delay its review of the PM₁₀ NAAQS rulemaking due to concerns raised by the American Iron and Steel Institute about the integrity of the Six Cities data base. 902 F.2d at 974. In that case, EPA had relied upon an earlier Dockery study based on the Six Cities data base. Although the National Institutes of Health (NIH) undertook a review of the allegations regarding the Six Cities database, the court nevertheless upheld EPA's reliance on that Dockery study without waiting for the results of the NIH review. NIH eventually concluded that the allegations were without merit. According to the court in the NRDC case:

AISI claims that the EPA relied *too much* on the Six Cities Study, which is comprised of the Dockery study and the Ware study * * *. We do not agree that the Administrator's selection of the twenty-four hour standard lacks the necessary reasoned analysis and supportive evidence * * *. After carefully reviewing the record, we find EPA's selection of the twenty four hour standard reasonable in light of the divergent results in the studies and the agency's mandate to provide an adequate margin of safety. Studies contained in the record provided evidence of adverse health effects at levels below 250 µg/m³.

902 F.2d at 969 (footnotes omitted; *emphasis in original*). The court also stated that:

In setting a standard under section 109 of the Act, the Administrator must "take into account all the relevant studies revealed in the record" and "make an informed judgment based on available

⁹² EPA also does not agree that because the language of section 307(d) of the Act mentions "factual data" as well as "the methodology used in obtaining and analyzing the data," EPA cannot rely on a study alone. In this case, the study is the "factual data" and EPA's methodology used in obtaining and analyzing the "factual data" is the method that EPA used to review and rely upon the studies. This methodology is discussed extensively in the staff paper and summarized in some detail elsewhere in this preamble. In fact, as is clear from the overall structure of section 307(d) of the Act, as well as the legislative history cited in this unit, section 307(d) of the Act merely requires that EPA summarize and disclose the information and methodology that it relied upon in developing its rule. It leaves unchanged the "level" of support that an agency must bring to bear in drafting a proposed rule.

evidence.” *American Petroleum Institute v. Costle*, 665 F.2d at 1187. The record shows that the Administrator did so. The Administrator relied on studies which showed adverse effects at and below the 250 µg/m³ level. AISI essentially asks this court to give different weight to the studies than did the Administrator. We must decline. It is simply not the court’s role to “second-guess the scientific judgments of the EPA. * * * [T]he Administrator did not act arbitrarily in drawing conclusions from the uncertain and conflicting data. The Administrator may reasonably apply his expertise to draw conclusions from “imperfect data,” *Ethyl Corp.*, 541 F.2d at 28, as he did here.

Id. at 971.

As this language makes plain, the term “data” may include a study relied upon by EPA. It should be equally plain that EPA may properly rely on such a study in setting a standard despite the fact that such “data” may be “imperfect,” “conflicting,” and “uncertain.” There are numerous other cases in which EPA has relied on studies in setting standards under the Clean Air Act. See, e.g., *Engine Manufacturers Association v. EPA*, 88 F.3d 1075, 1099 (D.C. Cir. 1996) (upholding EPA’s use of the 1993 Dockery study for setting mobile source standards); *API v. Costle*, 665 F.2d 1176, 1185 (D.C. Cir. 1981) (Administrator’s conclusion that normal body functions are disrupted by ozone is “supported by the studies”).

A number of commenters cited *Endangered Species Committee v. Babbitt*, 852 F. Supp. 32 (D.D.C. 1994) (hereafter “Gnatcatcher”) in support of the proposition that EPA must obtain and disclose the raw data underlying the Dockery and Pope studies. Relying on cases such as *Connecticut Light and Power Co. v. NRC*, 673 F.2d 525 (D.C. Cir. 1982), *Portland Cement v. Ruckelshaus*, 486 F.2d 375 (D.C. Cir. 1973), and *United States v. Nova Scotia Food Processing Corp.*, 568 F.2d 240 (2d Cir. 1977), these commenters suggest that “a body of legal decisions is emerging whereby federal courts are increasingly dubious of final regulatory decisions that are being made absent public scrutiny of the data underlying and purportedly supporting such decisions.” According to these commenters, based on Gnatcatcher and other cases, failure by EPA to obtain and place in the docket the raw unanalyzed data used in the Dockery and Pope studies constitutes serious procedural error under the Clean Air Act.

Under *Connecticut Light and Power*, agencies must make available technical studies and data that have been relied upon during the rulemaking process in order for the public to have an adequate opportunity for notice and comment. There is no question that EPA has done this with regard to the Dockery and Pope studies, which are included in the rulemaking docket. The *Portland Cement* case makes clear that where an agency actually relies on factual data it cannot “promulgate rules on the basis of inadequate data, or on data that, [to a] critical degree, is known only to the agency.” 486 F.2d at 393. See also,

Nova Scotia, 568 F.2d 240, at 251 (where all of the research was collected by the agency, and none of it was disclosed “as the material upon which the proposed rule would be fashioned,” error resulted); *CMA v. EPA*, 870 F.2d 177, 200 (5th Cir. 1989) (“fairness requires that the agency afford interested parties an opportunity to challenge the underlying factual data relied on by the agency”).

However, in this case, EPA did not rely on, nor did it ever have or review, the underlying data used in the Dockery and Pope studies. Instead, it relied upon the studies themselves. Thus, the cases cited in this unit are inapposite. They stand only for the proposition that where an agency actually reviews and relies on “data,” which may be raw data, a study or a variety of other forms of information, it must make these data available. They do not and cannot stand for the proposition that an agency may not rely on a study alone and must always obtain the raw and unanalyzed data underlying a study. Indeed, as one D.C. Circuit case noted: “Portland Cement and Nova Scotia simply cannot be twisted so as to require notices of proposed or interim rules to contain elaborate reproductions of underlying studies.” *Petry v. Block*, 737 F.2d 1193, 1198 (D.C. Cir. 1984). Requiring EPA to obtain, analyze and disclose the data underlying the Pope and Dockery studies, which EPA neither reviewed nor relied upon, would be to require EPA to attempt such an “elaborate reproduction.” Such a step is not required under the law and would make it extremely difficult, if not impossible, for EPA to regulate in complex, technical areas “at the frontiers of science.” *Baltimore Gas and Electric Co. v. NRC*, 462 U.S. 87 (1983).

The district court’s decision in the Gnatcatcher case is similarly inapposite. That case concerned a scientific study regarding the range of the California Gnatcatcher, a small insectivorous songbird. As the Gnatcatcher opinion itself notes, “courts have generally allowed agencies to rely on scientific reports.” *Gnatcatcher*, 852 F.Supp. at 37. Thus, the question at issue in Gnatcatcher was whether specific circumstances exist in which an agency may not be entitled to rely on studies alone. In the Gnatcatcher case, a single author had published two directly contradictory studies on the same issue, while relying on the same data. In light of this clear contradiction, commenters in that rulemaking argued that without the underlying data it was impossible to determine whether the conclusions in either study were correct. The district court noted that:

The Secretary had before him a report by an author who, two years before had analyzed the same data and come to an opposite conclusion. It is the disputed nature of this report that distinguishes this from other cases where a scientific report alone has been considered sufficient for ESA purposes.

Id. Thus, according to the court: “While courts have generally allowed agencies to rely on scientific reports * * * this is not sufficient in this case because the report itself is under serious question.” *Id.*

The EPA’s current reliance on the Dockery and Pope studies bears no resemblance to the circumstances present in the Gnatcatcher decision. As noted previously, these studies have been subject to extensive peer review and scrutiny, and neither researcher has published a contradictory study on the same issue, much less using the same data base. The EPA is not aware of, nor have any of the commenters raised any particular issues relating to either gross error, fraud or scientific abuse arising from the data. Indeed, as noted previously, the prior work of these particular researchers has been subject to extensive independent scrutiny and reanalysis, which has confirmed, rather than called into question, the underlying validity of their conclusions and the integrity of their research methods. Reading Gnatcatcher to suggest that EPA cannot rely on such a study, where the study and its methods have been subject to extensive peer review, would place the district court’s rationale in Gnatcatcher in conflict with applicable D.C. Circuit precedent that makes evident the right of agencies to rely on studies alone. See, e.g., *Engine Manufacturers Association v. EPA*, 88 F.3d 1075, 1099 (D.C. Cir. 1996); *API v. Costle*, 665 F.2d 1176, 1185 (D.C. Cir. 1981), “studies discussed in the Criteria Document constitute a rational basis for the finding that adverse health effects occur at ozone levels of 0.15-0.25 ppm for sensitive individuals”; see also, *NRDC v. Thomas*, 805 F.2d 410, 418 (D.C. Cir. 1986) (EPA use of a summary of confidential data that was not disclosed provides “a reasoned explanation for moving from a 4.0 to 5.0 long term NO_x standard”).

In addition, to require EPA to obtain and analyze the data prior to revising the standard would also contradict the “common sense notion that Congress, in providing for notice and comment under the APA, could not have intended to subject the agencies—and the public on whose behalf they regulate—to [a] sort of interminable back and forth.” *International Fabricare Institute v. EPA*, 972 F.2d 384, 399 (D.C. Cir. 1992). In the view of some commenters, EPA has no choice but to either postpone its decision for a year or more awaiting a review of data or choose to retain the current standard. Yet were EPA to adopt such an approach, these commenters would undoubtedly insist that EPA be required to include an analysis of the data in the docket; further questions would likely be raised regarding the re-analysis and once again EPA might find itself unable to promulgate its rule pending review of further hypothetical questions. This type of unending inquiry is not required under the law. As the D.C. Circuit has noted:

*** [D]isagreement among the experts is inevitable when the issues involved are at the "very frontiers of scientific knowledge," and such disagreement does not prevent us from finding that the Administrator's decisions are adequately supported by the evidence in the record ***. It is not our function to resolve disagreement among the experts or to judge the merits of competing expert views ***. Cf. *Hercules, Inc. v. EPA*, 598 F.2d 91,115 (D.C. Cir. 1978) ("[c]hoice among scientific test data is precisely the type of judgment that must be made by EPA, not this court").

Lead Industries Association v. EPA, 647 F.2d 1130, 1160 (D.C. Cir. 1980).

Neither *Gnatcatcher*, nor any other case can fairly be read to suggest that EPA has an obligation to respond to all possible questions that might be raised regarding its scientific conclusions or that where EPA relies on a study, it must engage in a multi-phased and possibly unending re-examination of the data supporting such a study until all commenters are satisfied in full with the details of the underlying science. Even assuming that EPA could obtain the confidential Six Cities data through litigation, a substantial delay of many months, if not years, would likely result, in order for both EPA and industry to reanalyze the data. In the meantime, some tens of thousands of premature deaths could result. Neither the Clean Air Act nor relevant case law requires or permits such a result.

Indeed, the suggestion that EPA cannot and should not rely upon the Pope, Dockery, and Schwartz studies, unless and until interested parties have had an opportunity to examine and reanalyze the underlying raw data, is extraordinary. Given the precautionary nature of section 109 of the Act and the need to allow an adequate margin of safety, see *Lead Industries*, 647 F.2d at 1154, 1155, there are limits on EPA's discretion to disregard even studies that are clearly flawed, if they are nonetheless "useful" in indicating the kind and extent of health effects that may result from the presence of a pollutant in the ambient air. See sections 109(b)(1) and 108(a)(2) of the Act.

A few commenters cited *Kennecott v. EPA*, 684 F.2d 1007 (D.C. Cir. 1982) and argued that under sections 307(d)(8) and 307(d)(9)(D) of the Act, a failure by EPA to obtain and include in the docket the data underlying the Pope and Dockery studies would constitute an "error" that is "so serious and related to matters of such central relevance to the rule that there is a substantial likelihood that the rule would have been significantly changed if such error[] had not been made."⁹³ EPA disagrees. Peer reviewed

⁹³ One commenter argued that EPA's failure to place the "data" in the docket was not an "error" but a "refusal to comply with the clear language of the law that should be reviewed by the courts under section 307(d)(9)(C), rather than 307(d)(9)(D)." As noted previously, EPA does not agree with this interpretation of section 307(d)(3) of the Act. Under applicable caselaw, the term "data" may include information in many forms, including studies that EPA has placed in the docket. See *Endangered Species Committee v. Babbitt*, 852 F. Supp.

studies conducted by outside parties were not at issue in *Kennecott*. *Kennecott* involved a dispute over financial analyses that EPA itself had previously conducted and used in earlier rulemakings. The court determined that the financial analyses at issue must have provided at least part of the factual basis for EPA's rule, and EPA referenced these analyses in the preamble to the final rule without placing them in the docket until one week before promulgation. The factual circumstances in *Kennecott* are substantially different than the current situation and thus, *Kennecott* cannot fairly be read to establish the applicable legal standard with regard to EPA's reliance on peer reviewed studies for use in setting the NAAQS.

In this case, EPA—well before proposal—has placed the information that it relied upon in the docket. This information is in the form of studies. These studies have been subject to extensive scrutiny and peer review. To date no specific allegation has been made that the studies are clearly in error or that the data underlying them are the subject of fraud, scientific misconduct, or gross error going to the basic validity of the studies.⁹⁴ Instead, various commenters have merely stated their view that were the raw data behind these studies available, they would be able to better verify and assess the results reached in the studies.

As one commenter noted, "In the absence of data on which EPA's proposal is based, [key scientific] issues remain shrouded in uncertainty and skepticism. The disclosure of the data would allow for robust scientific analysis and discussion of these issues." A similarly hypothetical concern is raised by another commenter who stated that "seeing the data would clarify substantial questions of methodology" and "had the Harvard data been available, a far broader evaluation of the defects of the Harvard Studies would have been possible with the same expenditure of time and money." Yet, despite having spent "in the neighborhood of a million dollars to duplicate and reanalyze the Harvard data set" this commenter was unable to allege any particular defect in the methodology or results of these studies and noted instead that "the track record to date suggests that the claimed associations to PM_{2.5} and health effects would not have held up under such a broader evaluation."

^{32, 37} (D.D.C., 1994) ("data can come in many forms: it can be a scientific report, it can be graphs and tabulations *** it can be raw numbers").

⁹⁴ A number of commenters did argue these studies do not form a sufficient basis for EPA's decision to revise the NAAQS and that attempts to replicate these studies have not been universally successful. These same commenters also listed a number of hypothetical questions and issues that might be resolved through a review of the underlying data and suggested that before EPA may properly rely on these studies to revise the NAAQS, a variety of confounders (such as smoking) should also be ruled out by reviewing the data. As set forth more fully in Unit II. of this preamble, neither EPA nor CASAC agrees that any of these factors precludes reliance on the studies in question.

EPA is not required to await the results of such an inquiry before proceeding to regulate to protect human health and the environment. The concerns raised by the commenters regarding these studies remain hypothetical; the comments themselves raise no allegations of fraud, scientific misconduct or gross error that calls into question the fundamental validity of the studies. Given this fact, EPA does not agree with the commenters that reliance on these studies and/or a failure to place the underlying data in the docket constitutes an error, much less an error that is "so serious and related to matters of such central relevance that there is a substantial likelihood that the rule would have been significantly changed." EPA is entitled to rely upon these studies and it has satisfied its obligation to provide the "factual data" upon which the proposed rule is based by placing these studies in the docket.

In fact, the concerns raised by the commenters ultimately boil down to a disagreement with EPA over the level of scientific certainty necessary to adopt the NAAQS revisions. In setting standards under the Clean Air Act, EPA is not required to resolve all scientific issues to the complete satisfaction of every interested party. As noted by the D.C. Circuit in *Lead Industries Association v. EPA*, 647 F.2d 1130, 1160 (D.C. Cir. 1980):

To be sure, the Administrator's conclusions were not unchallenged; both LIA and the Administrator are able to point to an impressive array of experts supporting each of their respective positions. However, disagreement among the experts is inevitable when the issues involved are at the "very frontiers of scientific knowledge," and such disagreement does not preclude us from finding that the Administrator's decisions are adequately supported by the evidence in the record. It may be that LIA expects this court to conclude that LIA's experts are right, and the experts whose testimony supports EPA are wrong. If so, LIA has seriously misconceived our role ***. It is not our function to resolve disagreement among the experts or to judge the merits of competing expert views ***. Cf. *Hercules, Inc., v. EPA*, 598 F.2d 91, 115 (D.C. Cir. 1978) ("[c]hoice among scientific test data is precisely the type of judgment that must be made by EPA, not this court").

647 F.2d at 1160 (footnotes omitted).

The EPA's rationale for proposing to add a fine particle standard was detailed in the preamble to the proposed rule, most notably at 61 FR 65654–65662, December 13, 1996. This decision is based on the extensive review of the science and policy issues contained in the PM Criteria Document and Staff Paper; the CASAC concluded, after extensive review, that both of these documents were appropriate for use in decision making on standards. These documents contain a full discussion of both what is known about PM and the information gaps and uncertainties. Considering the full weight of the scientific evidence, including the uncertainties, the CASAC recommended that the Administrator adopt fine particle

standards and a number of panel members based their support for a PM_{2.5} standard on the following reasoning:

[T]here is strong consistency and coherence of information indicating that high concentrations of urban air pollution adversely affect human health, there are already NAAQS that deal with all of the major components of that pollution except PM_{2.5}, and there are strong reasons to believe that PM_{2.5} is at least as important as PM_{10-2.5} in producing adverse health effects.

Wolff, 1996.

Given the consistency and coherence of the evidence that premature mortality and sickness occur in large numbers of Americans at concentrations permitted by the current standards, it would be irresponsible to delay action that would put more appropriate air quality goals into place based on the most recent scientific information. After a review of the comments submitted, the Agency's conclusion that it is appropriate to rely on the existing studies remains unchanged.

D. 1990 Amendments

Contrary to the view expressed in some public comments, the provisions of subpart 4 of Part D of Title I of the Act, enacted in 1990, do not preclude EPA from adopting PM_{2.5} as an additional indicator for PM and establishing standards for PM_{2.5}. The provisions of subpart 4 of Part D of Title I of the Act simply do not limit EPA's clear authority under section 109 of the Act to revise the PM standards.

The basic contention is that because the provisions of subpart 4 of Part D of Title I of the Act refer to PM₁₀, they prohibit EPA from regulating any other type of PM, for example, by revising the existing NAAQS for PM by adopting an ambient air quality standard for PM_{2.5}. These provisions, however, do not lead to such a conclusion. Moreover, this view ignores provisions indicating that Congress believed that EPA could revise any existing NAAQS or adopt a new NAAQS.

At the outset, it should be noted that Congress expressly authorized EPA to revise any ambient air quality standard and to adopt a new NAAQS in section 109 of the Act. That section, which requires EPA to review and revise, as appropriate, each NAAQS every five years, contains no language expressly or implicitly prohibiting EPA from revising a NAAQS or adopting a new NAAQS. If Congress had intended to preclude EPA from reviewing and revising a NAAQS or adopting a new NAAQS, which are part of EPA's fundamental functions, Congress would have specifically done so. Clearly, Congress knew how to preclude EPA from exercising otherwise existing regulatory authority and did so in other instances. See section 202(b)(1)(C) of the Act (expressly precluding EPA from modifying certain motor vehicle standards prior to model year 2004); section 112(b)(2) of the Act (preventing EPA from adding to the list of

hazardous air pollutants any air pollutants that are listed under section 108(a) of the Act unless they meet the specific exceptions of section 112(b)(2) of the Act); section 249(e)(3), (f) and section 250(b) (limiting EPA's authority regarding certain clean-fuel vehicle programs). No such language was included either in section 109 of the Act or elsewhere in the Act and no such implication may properly be based on the provisions of subpart 4 of Part D of Title I of the Act.

Second, other provisions of the Act expressly contemplate EPA's ability to promulgate a new or revised NAAQS, and provide no indication that such ability is limited to standards other than those whose implementation is the subject of subparts 2, 3 and 4 of Part D of Title I of the Act. For example, section 110(a)(2)(H)(i) of the Act provides that SIPs are to provide for revisions "from time to time as may be necessary to take account of revisions of such national primary or secondary ambient air quality standard * * *." Section 107(d)(1)(A) of the Act provides a process for designating areas as attainment, nonattainment, or unclassifiable "after promulgation of a new or revised standard for any pollutant under section 109 * * *." Section 172(e) of the Act addresses modifications of national primary ambient air quality standards. Finally, section 172(a)(1) of the Act expressly contemplates that EPA may revise a standard in effect at the time of enactment of the 1990 Clean Air Act Amendments. Section 172(a)(1)(A) of the Act provides EPA with authority to classify nonattainment areas on or after the designation of an area as nonattainment with respect to "any revised standard, including a revision of any standard in effect on the date of the enactment of the Clean Air Act Amendments of 1990." Plainly, Congress had no intention of prohibiting EPA from revising any of the ambient standards in effect at the time of the enactment of the 1990 amendments.

Third, the provisions of subpart 4 of Part D of Title I of the Act do not support the contention that they somehow preclude EPA from exercising its authority to adopt a revised PM NAAQS based on a metric other than PM₁₀. The fact that Congress laid out an implementation program for the PM standard existing at the time of the 1990 amendments in no way suggests that Congress intended to preclude EPA from exercising the authority it provided EPA to revise the NAAQS when the health data on which EPA bases such decisions warranted a change in the standard.

The fact that Congress drafted subpart 4 of Part D of Title I of the Act in 1990 to specify the implementation regime for the PM standard then in effect, a PM₁₀ standard, in terms that explicitly refer to PM₁₀ in no way suggests that Congress meant to preclude EPA from adopting a PM standard based on another metric if scientific information supported such a change. Obviously, PM₁₀

was the standard in existence in 1990 and Congress drafted subpart 4 of Part D of Title I of the Act, the purpose of which was to delineate an implementation regime for that standard, in terms of that standard. There is simply no language in subpart 4 of Part D of Title I of the Act that limits EPA's ability to establish a different PM standard if such a standard were warranted under section 109 of the Act or indicates any implicit intent on the part of Congress to limit EPA's authority under section 109 of the Act in such a way. Subpart 4 of Part D of Title I of the Act simply does not speak to the question of whether EPA may establish a PM standard based on a different metric. In addition, section 107(d)(4) of the Act, the only provision outside of subpart 4 of Part D of Title I of the Act invoked as a basis for the view that the Act prohibits EPA from adopting a PM_{2.5} standard, does not support that view. That provision simply preserved pre-existing designations for "total suspended particulates," the PM metric utilized prior to PM₁₀, for certain purposes. It provides no suggestion that Congress intended to prohibit EPA from adopting a metric other than PM₁₀. Indeed, if anything, it indicates that Congress was fully aware that EPA had previously changed the PM metric used in the PM NAAQS and confirms the view that Congress would have explicitly barred EPA from changing the metric had it intended to do so.

Finally, for the reasons stated in this unit, EPA's analysis of its ability to implement a PM_{2.5} standard under the provisions of subpart 1 of Part D of Title I does not support the view that Congress prohibited EPA from promulgating such a standard. Congress clearly specified an approach to the implementation of the PM₁₀ standard in the provisions of subpart 4 of Part D of Title I of the Act. The EPA believes that the clear and express linkage of that approach to the PM₁₀ standard indicates that a different PM standard should be implemented under the general principles of subpart 1 of Part D of Title I of the Act. That Congress directed specifically how EPA and the States should implement the PM₁₀ standard does not carry with it the implication that Congress intended to prohibit EPA from exercising its otherwise clear and express authority to adopt a PM standard based on a different metric in order to carry out one of its fundamental missions, the establishment of ambient air quality standards to protect public health with an adequate margin of safety. It is entirely reasonable and logical for Congress to, on the one hand, specify an implementation regime for the PM standard in effect at the time of enactment of the 1990 amendments, but, on the other hand, leave EPA free to exercise the authority provided it by Congress in section 109 of the Act to adopt a new or revised standard when EPA determined that such a standard was needed to protect public health with an adequate margin of safety. Congress

explicitly required EPA to review and revise as appropriate the NAAQS every five years. If Congress did not intend for EPA to revise the NAAQS when warranted, it would not have required EPA to review and revise them. If Congress had intended to prohibit EPA from exercising such a fundamental authority it would have clearly specified, as it did in other instances, that EPA could not do so.

V. Revisions to 40 CFR Part 50, Appendix K—Interpretation of the PM NAAQS

Because the revocation of the existing PM₁₀ standards will become effective at a later date (as discussed in Unit VII. of this preamble), EPA is retaining 40 CFR part 50, Appendix K, although it is being published today in revised format to conform with the format of the other appendices in this part. A new Appendix N to 40 CFR part 50 explains the computations necessary for determining when the primary and secondary PM_{2.5} and PM₁₀ standards being adopted today are met. The discussion in this unit sometimes refers to the contents of the new Appendix N as revisions to Appendix K, so as to highlight how the new Appendix N differs from the current Appendix K.

Key elements of the new 40 CFR part 50, Appendix N, particularly as they differ from those of Appendix K, are outlined in this unit.

A. PM_{2.5} Computations and Data Handling Conventions

As discussed in Unit II.E. of this preamble, the form of the annual PM_{2.5} standard is a spatially averaged annual mean averaged over 3 years, and the form of the 24-hour PM_{2.5} standard is a 98th percentile concentration averaged over 3 years.

With regard to the annual PM_{2.5} standard, the EPA proposed a form expressed as the annual arithmetic mean, averaged over 3 years and spatially averaged over all designated monitoring sites to represent population exposures. As discussed in Unit II.E.1. of this preamble, the form of the annual PM_{2.5} standard has been clarified to make explicit that implementing agencies have the flexibility to base comparison of the standard level with measured values from either a single community-oriented site or an average of measured values from such monitors within the constraints enumerated in 40 CFR part 58. The new Appendix N of 40 CFR part 50 reflects this clarification. The spatial average, if used, is to be carried out using data from monitoring sites designated in a State PM Monitoring Network Description in accordance with the provisions of 40 CFR part 58.

Also, the EPA proposed that, for spatial averaging, the requirements for 3 years of data for comparison with the standard be fulfilled by the spatial averaging network as a whole, not by individual monitors within the network. The EPA received comments regarding the application of the 75 percent data completeness requirement to spatial

averaging. The commenters stated that the inclusion or exclusion of a site not meeting the data completeness requirements from a spatial average, based on the level of the single site average, would bias the spatial average for that year. The EPA has responded to the comment by demonstrating in Example 1 in 40 CFR part 50, Appendix N the application of the data completeness criterion that is consistent with a spatially averaged network. Specifically, the application of the data completeness requirement has been altered in the example if a particular site has quarters in a year that do not meet the minimum data completeness requirement. Instead of comparing a site's annual average to the level of the standard to decide whether or not to keep the site in the calculations, the annual average for all the sites (the spatial average) is compared to the level of the standard. If the spatial average is above the level of the standard, the site is kept in the calculations. If it is below, the site is omitted from the calculations.

The EPA also proposed that averaging over calendar quarters be retained for the annual average form of the standard. Although several commenters stated that the step of calculating quarterly averages to obtain the annual average was unnecessary, the EPA maintains that quarterly averages are important to ensure representative sampling in areas with extreme seasonal variation.

Regarding the 75 percent data completeness requirement, the proposal stated that a given year meets data completeness requirements when at least 75 percent of the scheduled sampling days for each quarter have valid data, and high values measured in incomplete quarters shall not be ignored but shall be included if their value causes the annual calculation to be above the level of the standard. Some commenters felt that this treatment was unfair in that measured data below the standard in incomplete quarters are not retained. In addition, the commenters felt that this could create a bias where a single sample could inflate an annual average to a level above the standard. The EPA agrees and has incorporated in 40 CFR part 50, Appendix N the following provisions.

(1) A statement has been added that less than complete data may be used in certain cases subject to the approval of the appropriate Regional Administrator in accordance with EPA guidance for dealing with less than complete data. This statement was considered necessary for those situations where measured data and air quality analyses would indicate that the area met or did not meet the standard although it did not exactly meet the data completeness requirements.

(2) A provision has been added that a minimal amount of data is needed before the requirement to retain high values in an incomplete quarter comes into effect for the annual standards. Sites with at least 11 samples but less than 75 percent data completeness in a quarter will have to include

high values if they result in calculated values which are above the level of the standard. This provision is based upon the change in sampling frequency set forth in the revisions to 40 CFR part 58 which effectively doubles the minimum sampling frequency from 1-in-6 day sampling to 1-in-3 day sampling. The data completeness requirement for the annual form of the standard under the original 1-in-6 day sampling schedule is equivalent to a minimum of 37.5 percent under the new sampling schedule of 1-in-3 days. This is equivalent to a minimum of 11 samples in each quarter. Therefore, a minimum of 11 samples in a quarter should be sufficient for an annual average above the level of the standard to be used under the new sampling schedule.

(3) In sharp contrast, this minimum requirement was considered unnecessary for the 24-hour form of the standard when the 98th percentile is above the level of the standard. That is, for a site with a 98th percentile above the level of the standard that does not meet the 75 percent data completeness requirement, the 98th percentile would be equivalent to the maximum or second maximum daily concentration in that year. While adding more data samples up to the minimum data completeness requirement of 75 percent could help to ensure that the second maximum value (rather than the maximum value) corresponds to the 98th percentile, this difference is not considered significant enough to require some minimal number of data samples when dealing with the form of the 24-hour standard.

With regard to the 24-hour PM_{2.5} standard, the proposed revision to 40 CFR part 50, Appendix K defined the 98th percentile as the daily value out of a year of monitoring data below which 98 percent of all values in the group fall. The calculation of the percentile form has been revised to reflect general comments that the form of the standard and its calculation should be simplified. The EPA maintains that the revised calculation is consistent with the definition of the percentile being that number below which a certain percent of the data fall.

Regarding the expression of the annual standard to the nearest 0.1 µg/m³ and the 24-hour standard to the nearest 1 µg/m³, virtually no commenters disagreed with the EPA's proposed approach. The few that did, however, took issue with the overall stringency of the standards, not the rationale discussed in the proposal. The EPA maintains its position that instrument sensitivity and the number of measured values used in calculating the values to be compared to the standard, as discussed at length in the proposal, point to keeping the expressions of the standards stated in this unit.

B. PM₁₀ Computations and Data Handling Conventions

As discussed in Unit II.G. of this preamble, the EPA proposed retaining the current

annual arithmetic mean, averaged over 3 years, as the form of the annual PM_{10} standard, and changing the form of the 24-hour PM_{10} standard to a 98th percentile value form, averaged over 3 years. As discussed in Unit II.G. of this preamble, the form of the daily PM_{10} standard has been revised to a 99th percentile instead of the 98th percentile, and the related calculations have been revised accordingly. The same revision described above in Unit V.A. of this preamble to simplify the formula used to calculate the percentile form of the 24-hour $PM_{2.5}$ standard also applies to the PM_{10} 99th percentile calculation.

The revisions made to the annual and 24-hour $PM_{2.5}$ standards regarding the 75 percent data completeness requirement also apply to the annual and 24-hour PM_{10} standards. Appendix N of 40 CFR part 50 reflects this change.

As with the $PM_{2.5}$ standards, the EPA maintains its position that instrument sensitivity and the number of measured values used in calculating the values to be compared to the standard, as discussed in detail in the proposal, point to keeping the expressions of the standards to the nearest 1 $\mu\text{g}/\text{m}^3$ for the annual standard and to the nearest 10 $\mu\text{g}/\text{m}^3$ for the 24-hour standard.

C. Changes That Apply to Both $PM_{2.5}$ and PM_{10} Computations

In the proposal, the EPA stated that revisions to 40 CFR part 50, Appendix K would not address the treatment of exceptional events data, which are considered part of the standards implementation process. Since several commenters mentioned the handling of these events in conjunction with the proposed revisions to Appendix K, the EPA has addressed this concern in Appendix N of 40 CFR part 50, which states that whether to exclude, retain, or make adjustments to data affected by uncontrollable or natural events is subject to the approval of the appropriate Regional Administrator.

Comments were also received expressing the desire of some areas to conduct seasonal sampling, reducing the frequency of monitoring during a period of expected low concentrations to save resources. The proposed revision to 40 CFR part 50, Appendix K did not prohibit this course of action, and referred matters of sampling frequency to 40 CFR 58.13. For clarification, 40 CFR part 50, Appendix N adds that exceptions to specified sampling frequencies, such as a reduced frequency during a season of expected low concentrations, shall be subject to the approval of the appropriate Regional Administrator.

VI. Reference Methods for the Determination of Particulate Matter as PM_{10} and $PM_{2.5}$ in the Atmosphere

A. Revisions to 40 CFR Part 50, Appendix J—Reference Method for PM_{10}

Because the revocation of the existing PM_{10} standards will become effective at a later date (as discussed in Unit VII. of this preamble), EPA is retaining Appendix J in its current form. A new Appendix M to 40 CFR part 50 establishes the reference method for measuring PM_{10} in the ambient air for the revised PM_{10} standards. The discussion in this unit sometimes refers to the contents of the new Appendix M as revisions to Appendix J, so as to highlight how the new Appendix M differs from the current Appendix J. As discussed below, the only revision to the Reference Method for PM_{10} relates to the calculation of the volume of air sampled.

During the course of this standards review, EPA has received a number of comments regarding the appropriateness of the current practice of adjusting measured PM_{10} concentrations to reflect standard conditions of temperature and pressure (25° C and 760 mm Hg, respectively), as required by 40 CFR part 50, Appendix J. The practice was originally adopted to provide a standard basis for comparing all pollutants measured in terms of mass per unit volume (e.g., $\mu\text{g}/\text{m}^3$). As EPA has reviewed the ambient standards for gaseous pollutants, however, technical changes have been made to express them on a pollutant volume/air volume basis (i.e., ppm) that is insensitive to differences in altitude and temperature. Such an approach is not applicable to particulate pollutants. The question arises whether continuing the past practice of making temperature and pressure adjustments for PM is appropriate or necessary.

Information in the Criteria Document on the health and welfare effects of PM provides no clear basis for making such adjustments. Recent health effects studies have been conducted in cool and warm climates, and in cities at high altitude, e.g., Denver, as well as near sea level, e.g., Philadelphia (U.S. EPA, 1996a). These studies provide no evidence that risk associated with PM exposures is affected by variations in altitude. Accordingly, any effect that would be accounted for by temperature and pressure adjustments would be below the detection limits of epidemiological studies. While extremes of altitude might be expected to increase the delivered dose of PM in those not acclimatized to such locations, the dosimetric studies summarized in the Criteria Document provide no clear support for any quantitative adjustment to standard conditions. With respect to welfare effects, visibility is directly related to the actual mass of fine particles in the atmosphere. Adjustment of PM concentrations collected at higher altitudes to standard conditions would

therefore lead to an overstatement of the effect of PM on visibility in such locations. Similarly, there is no evidence in the Criteria Document suggesting that effects on materials damage and soiling are dependent on altitude.

Based on this assessment, EPA proposed to delete the requirement to adjust PM_{10} concentrations to standard conditions of temperature and pressure from 40 CFR part 50, Appendix J for the revised standards and to make corresponding revisions in 40 CFR 50.3. Comments received on this issue were divided. A number of commentors supported EPA's proposal for the reasons set forth above. A few States opposed the change because the lack of adjustment for very cold temperature in areas near sea level could make the standard more stringent. Some commentors were concerned that the proposed change would relax protection afforded for areas at high altitude. A few commentors expressed concern that "sojourners" who visit high altitude area would have higher ventilation rates and receive reduced protection as compared to local residents whose ventilation patterns were more adapted to these conditions.

The EPA does not believe that the localized comparisons regarding increased or decreased stringency of standards relative to the proposed change are an appropriate rationale for keeping the current adjustment for temperature and pressure. The issue is whether the available scientific evidence on the health and welfare effects of PM provides a basis for continuing with the traditional adjustments. The comments with respect to sojourners at altitude are relevant, but this issue was considered in reaching the proposed decision. Furthermore, commentors provided neither laboratory nor epidemiologic evidence that would support their theoretical concerns regarding increased annual or 24-hour PM effects at altitudes typical of mountainous urban areas in the United States.

Based on its assessment of the available evidence and public comments, EPA concludes that a continuation of the practice of adjusting PM_{10} concentrations to standard conditions of temperature and pressure is not warranted or appropriate. Accordingly, this requirement is not included in 40 CFR part 50, Appendix M and corresponding revisions are made in 40 CFR 50.3. In addition, EPA is also incorporating the proposed minor modifications to 40 CFR part 50, Appendix J in Appendix M.

B. 40 CFR Part 50, Appendix L - New Reference Method for $PM_{2.5}$

1. *Introduction.* A new reference method for the measurement of fine particles (as $PM_{2.5}$) in the ambient air has been developed for the primary purpose of determining attainment of the new $PM_{2.5}$ standards. The method is described in the new 40 CFR part 50, Appendix L, and joins the other reference methods (or measurement principles)

specified for other criteria pollutants in other appendices to 40 CFR part 50.

In developing the proposed new reference method for PM_{2.5}, EPA staff consulted with a number of individuals and groups in the monitoring community, including instrument manufacturers, academics, consultants, and experts in State and local agencies. The approach and key specifications were submitted to the CASAC Technical Subcommittee for Fine Particle Monitoring, which held a public meeting to discuss the proposed new reference method for PM_{2.5} and related monitoring issues on March 1, 1996. Comments on the proposed method were provided orally and in writing by interested parties. The Technical Subcommittee indicated their overall satisfaction with the method in a letter (Price, 1996) forwarded by CASAC to the Administrator.

On December 13, 1996, EPA proposed the new 40 CFR part 50, Appendix L at 61 FR 65676 for public comment. The proposal described in detail the approach taken and the design specifications and performance requirements for the new PM_{2.5} sampler. On January 14, 1997, EPA held a public hearing on the proposed new 40 CFR part 50, Appendix L and associated 40 CFR parts 53 and 58 requirements.

2. *Basic reference method approach.* In addition to the primary purpose of the new PM_{2.5} reference method (determining attainment of the standards), EPA considered a variety of possible secondary goals and objectives that the PM_{2.5} reference method might also fulfill. Subsequently, various alternative PM_{2.5} measurement techniques were evaluated. From this analysis, EPA proposed to base its PM_{2.5} reference method on a conventional type sampler that collects 24-hour integrated PM_{2.5} samples on a 47 mm Teflon filter that is subsequently moisture and temperature conditioned and analyzed gravimetrically. The sampler is a low volume sampler that operates at a flow rate of 1 cubic meter per hour, for a total sample volume of 24 m³ for the specified 24-hour sample collection period. The sampler is easy to operate, operates over a wide range of ambient conditions, produces a measurement that is comparable to large sets of previously collected PM data in existing databases, and provides a physical sample that can be further analyzed for chemical composition.

3. *Public comments and responses—*a. *Sampler design.* The EPA received many general comments concerning the proposed sampler design. Commenters suggested the use of a different indicator, use of a different size cut, inclusion of additional constituents (e.g., acid aerosols, carbon, metals, and semi-volatiles), and/or use of a multi-filter method. Early in the development process, design decisions were based on public input and the advice of CASAC on these and other basic design issues. Other factors affecting the

basic design of the method were the need for historical continuity, high measurement precision, and simplicity of operation, all in response to current national monitoring objectives and available resources. In selecting the basic measurement approach, substantial weight was given to maintaining comparability to PM_{2.5} samplers, such as the "dichotomous sampler," that were widely used to obtain the data upon which the new standards are based. Given this objective, EPA concludes that the conventional PM measurement approach is appropriate and will provide PM_{2.5} measurements that are comparable to the air quality data used in the health studies that provide the basis for the PM_{2.5} standards.

Although the sampler is conventional in configuration, its design is much more sophisticated than that of previous PM samplers. This more sophisticated sampler, together with improved manufacturing and operational quality assurance, is necessary to achieve the more stringent data quality objectives established for PM_{2.5} monitoring data. To meet precision requirements, the critical mechanical components of the inlet, particle size separator, downtube, and upper portion of the filter holder are specified by design. All other aspects of the sampler are specified by performance-based specifications.

Several commenters felt that the portions of the sampler that were specified by design would stifle further improvements and innovations. Although the EPA specifies methods by performance whenever possible, for the PM_{2.5} reference method, development of adequate performance specifications for inlet aspiration and particle size discrimination would have been a very difficult, costly, lengthy, and problematic process. Moreover, manufacturer testing of proposed inlet and particle size discrimination devices against such performance specifications would require elaborate specialized facilities and would be extremely costly. For these reasons, the EPA believes that specification of these critical components by design is a prudent and very cost-effective way to ensure good inter-manufacturer and intra-manufacturer precision of the PM_{2.5} measurements. Therefore, these components are specified by design, and other aspects of the sampler are specified by performance, as proposed. Innovations and improved samplers or measurement methods are encouraged and provided for as Class II and III equivalent methods (see 40 CFR part 53).

b. *Inlet and impactor design.* Several commenters addressed the inlet design, noting that the inlet could allow entrance of precipitation and possibly insects. In fact, the inlet selected for the sampler has been used effectively for many years to obtain many of the PM_{2.5} measurements that formed the basis of the epidemiological studies. While EPA acknowledges that there have been some reports of intrusion of precipitation, the

Agency believes the problem is relatively minor. Nevertheless, a modification of the inlet has been developed to further reduce the possibility of precipitation (and possibly small insects) reaching the sample filter to damage the PM_{2.5} sample. Extensive wind tunnel tests have shown no significant compromise in the PM_{2.5} aspiration performance of the modified inlet.

In addition, a new provision has been added, in 40 CFR part 50, Appendix L, section 7.3.8, to require that the sampling air entrance of the inlet be at a height of 2 ± 0.2 meters above the supporting surface to help ensure homogeneous air samples when collocated samplers of different types are operated simultaneously.

Other commenters addressed the sharpness of the size cut and how it is obtained, e.g., whether more than two stages should be used and what size cut should be used for each stage. These aspects were carefully considered in selecting the sampler configuration. The selection by EPA of the previously used PM₁₀ inlet established the size cut for the first stage, and the second stage was designed to be simple, reliable, and low in cost for user agencies. In EPA's estimation, the advantages of this configuration outweigh any modest advantage that might have been gained by designing a new inlet/separation configuration that would further refine the cut points at each of two (or more) stages.

A few commenters questioned whether the inlet was wind speed dependent at high wind speeds. The selected inlet has been shown to perform well up to 24 km/hr with 10 µm aerosols and is expected to perform well at higher speeds with 2.5 µm aerosols. The EPA again determined that the advantages of using the selected inlet outweighed the possible minor improvement in wind-speed characteristics that might have been obtained by a newly-designed inlet.

Some commenters felt that other types of particle discrimination techniques such as cyclones and virtual impactors, should be allowed. Again, these alternatives were evaluated previously and the specified inlet and impactor were determined to best meet the various objectives of the sampler. However, EPA has provided for considerations of other particle size selection techniques or devices for approval if incorporated into candidate equivalent methods for PM_{2.5}.

Several commenters addressed the impactor design, noting that the impactor should be changed to sharpen the size-cut characteristic, to address concerns regarding possible contamination and/or performance loss due to impactor oil, and to improve ease of access to service. To address the first concern, the initial prototype impactor has been modified slightly to sharpen its size-cut. The current impactor is designed to lower cost and to optimize cut sharpness, loading capacity, manufacturing simplicity,

manufacturing quality control, serviceability, and reliability. A report containing the penetration efficiency of the impactor is available in Docket No. A-95-54. With regard to impactor oil concerns, the impactor oil selected has a very low vapor pressure, and testing has indicated no contamination of the sample filters with impactor oil. The EPA believes that the impactor design is as accessible as possible, given the design objectives. Some flexibility may be allowed for manufacturers to develop improved closure devices or other external modifications. Proper maintenance will, of course, be very important and will be stressed in the associated operator instruction manuals and in other training and guidance materials. The EPA has been performing field and laboratory tests that will provide detailed guidance for all necessary preventive maintenance. Proper installation procedures for the oil and the impactor filter, as well as all other maintenance requirements, will be available in the quality assurance procedures and guidance contained in the new section 2.12 of Appendix L to be added to EPA's Quality Assurance Handbook for Air Pollution Measurement Systems (EPA/600/R-94/038b).

c. *Anodized aluminum surface.* All internal surfaces exposed to sample air prior to the filter are required to be anodized aluminum as stated in 40 CFR part 50, Appendix L, section 7.3.7. A few commenters expressed concern that the anodized aluminum surfaces in high volume PM₁₀ samplers have shown substantial pitting, particularly in the venturi flow control device. The anodized aluminum surfaces are required in the PM_{2.5} sampler to maintain comparability to previously used samplers. The EPA believes that the much lower flow rate in the PM_{2.5} sampler will greatly reduce the pitting tendency, and the active flow control in the PM_{2.5} sampler is not dependent on the physical dimensions of a critical orifice as it is in a venturi flow control device.

d. *Filter for PM_{2.5} sample collection.* The proposed reference method called for the sample to be collected on a 47 mm Teflon filter. Many of the comments received on the measurement method concerned the proposed filter medium and its performance. Commenters expressed concerns with the use of Teflon filters and with the selection of a single-filter method. Several commenters recommended that alternative filter media be allowed, in most cases to support speciation and/or to allow the capture of all PM components. Other comments noted potential advantages of other media in operating characteristics or chemistry requirements. Operational concerns expressed about Teflon filters included tearing, possible loss of integrity, and high cost. Other concerns were that Teflon is generally not conducive to carbon analysis, and that Teflon filters may not hold deposited PM. Many commenters recommended use of a multi-filter sampler to

support chemical speciation in addition to compliance determination.

To address some of these general concerns about the performance of the specified filter material, some minor refinements to the filter specifications concerning the filter diameter and the filter support ring have been made to ensure proper performance of the filter in the specified filter holder. Additional clarifications have been made to the maximum moisture pickup and the filter weight stability requirements. Although Teflon may preclude certain chemical analyses (e.g., elemental and organic carbon), the EPA believes that Teflon filter material is the best overall choice to meet the objectives of compliance monitoring and to provide good measurement precision. Other filter media are likely to provide reduced gravimetric precision and preclude more types of subsequent chemical analysis. Additional or alternative samplers or filter types can be considered as candidate equivalent methods under 40 CFR part 53 and can be used for non-compliance monitoring, where necessary.

Compliance monitoring based on mass concentration of PM_{2.5} is the primary objective of the reference method. Multi-filter capability would have substantially increased the cost and complexity of the sampler. However, multi-filter samplers can be considered as candidate equivalent methods. In addition, multi-filter samplers can be used as special purpose monitors (SPMs) to perform characterization studies, develop control strategies, and conduct other special studies as has been done previously for PM₁₀.

In response to numerous comments received on 40 CFR part 50, Appendix L and on the provisions of 40 CFR part 58 regarding the need for chemical speciation, the EPA is assigning a high priority to a chemical speciation trends network through section 105 of the Act grant allocation program and will issue guidance describing the monitoring methods and scenarios under which speciation should be performed. The program will incorporate additional PM_{2.5} samplers that allow for the simultaneous collection of aerosols on multiple filter media.

The associated requirement for archiving filters has been removed from 40 CFR part 50, Appendix L, section 10.17 and relocated to 40 CFR part 58, Appendix A. This change has been made because this is a supplemental monitoring requirement and not an integral part of the reference method for determining compliance with the PM_{2.5} NAAQS.

Provisions of 40 CFR part 50, Appendix L have been clarified to apply not only to a single-sample sampler, but also to a sequential-sample sampler, provided that all specifications are met and no deviations, modifications, or exceptions are made to the inlet, downtube, impactor, or the upper portion of the filter holder. Samplers that have minor changes or modifications in these components, have changes that alter the

aerosol's flow path, or contain other significant deviations will be required to meet the requirements of Class I equivalent methods, in the amendments to 40 CFR part 53. Further, a provision has been added to require that sequential sample filters stored in a sequential sampler be adequately covered and protected from contamination during storage periods in the sampler.

A few commenters expressed concern about who must carry out filter tests to determine if they meet the filter specifications. In response, the filter specifications have been clarified to indicate that filter manufacturers should generally carry out most or all of the filter performance tests in order to certify that their filters meet the filter specifications for the PM_{2.5} reference method. In addition, EPA conducts acceptance tests on filters procured for NAMS/SLAMS networks prior to distribution to State and local agencies.

Some commenters requested additional information on the requirement that an ID number be attached to each filter. Preliminary information indicates that it is not practical at this time for either filter manufacturers or users to print an ID number directly on the filter. However, EPA is continuing to pursue this goal. In the meantime, alternative means, such as attaching an appropriate ID number to the filter's storage container, will be necessary. Additional details and possible alternative filter identification methods will be provided in new section 2.12 of the Quality Assurance Handbook for Air Pollution Measurement Systems.

e. *Filter handling/weighing/conditioning requirements.* Many commenters felt that the filter handling requirements for collected PM_{2.5} samples were too burdensome. However, handling of the exposed filter between retrieval from the sampler and commencement of the conditioning period is expected to be one of the most significant sources of PM_{2.5} measurement variability. Thus, EPA concludes that specific requirements for this activity are necessary, and this position was supported by several commenters.

Some commenters felt that the samples should be kept cold until analysis to prevent volatile losses. In response to this concern, the restriction on the maximum temperature exposure for collected samples has been reduced from 32 to 25° C, and a recommendation has been added for sampler operators to keep the samples as cool as practical between retrieval from the sampler and delivery to the conditioning environment. Further, the length of time permitted between retrieval of the filter and post-collection weighing is increased from 10 to 30 days, provided that the sample is maintained at 4° C or less between retrieval and the start of the conditioning period. The new section 2.12 of the Quality Assurance Handbook for Air Pollution Measurement Systems will provide guidance and techniques for keeping samples

cool during this period and may suggest devices to document maximum temperature exposure of the sample.

Commenters also requested additional specifications and guidance for field blanks. The EPA will provide additional clarification and detailed procedures and guidance regarding field blanks in the new section 2.12 of the Quality Assurance Handbook for Air Pollution Measurement Systems.

Other commenters felt that the filter weighing requirements were too restrictive. Because filter weighing is one of the most significant sources of PM_{2.5} measurement variability, specific requirements and restrictions are deemed necessary. However, in response to some of the concerns expressed, the proposed requirement that both pre- and post-weighings be carried out by the same analyst has been reduced to a non-mandatory recommendation. Detailed recommendations and guidance on filter weighing, based on information obtained in current field tests, will be provided in the new section 2.12 of the Quality Assurance Handbook for Air Pollution Measurement Systems.

Several commenters questioned the filter conditioning requirements, with some requesting a lower humidity range. Since humidity can profoundly affect the weight of the PM_{2.5} on the filter, EPA maintains that filter conditioning requirements need to be tight to control measurement variability and to ensure satisfactory precision. But in response to at least one of the concerns, the filter conditioning humidity requirement has been changed to allow conditioning at a relative humidity within ± 5 RH percent of the mean ambient humidity during sampling (down to a minimum of 20 RH percent) for samples collected at average ambient humidities lower than 30 percent. The EPA will provide further details on filter conditioning controls in the new section 2.12 of the Quality Assurance Handbook for Air Pollution Measurement Systems.

f. Sampler performance requirements. Several commenters addressed sampler performance requirements, including sampler flow control specifications, filter temperature control, sampler performance under extreme conditions, and data reporting. In response to concerns that various sampler flow control specifications are too tight, EPA contends that good flow control is necessary to maintain uniform sampling, to ensure correct particle size discrimination, and to control measurement variability. Sampler manufacturers have been able to meet the specified flow control requirements, and field studies to date confirm that prototype samplers are able to meet these flow control requirements.

In response to comments about the ambient temperature plus 3° C filter temperature control requirement, EPA believes that fairly tight control of the sample filter temperature is necessary to minimize losses of semi-

volatile components over a wide temperature range, and tight temperature control has been strongly recommended by the CASAC.

Monitoring of the filter temperature difference from ambient temperature is necessary to verify that the sampler filter temperature control is functioning properly. Testing to date indicates that the proposed 3° C (above ambient temperature) limit is somewhat difficult to meet; however, a 5° C limit can be reasonably met. Therefore, the filter temperature control requirement has been relaxed slightly from 3° C to not more than 5° C above the concurrent ambient temperature. Ambient and filter temperature sensors will require periodic calibration or verification of accuracy. In response to a frequent comment, the method has been clarified to indicate that exceedance of the filter temperature difference limit would not necessarily invalidate the sample.

In response to concerns about the performance of the sampler under extreme weather conditions (e.g., high or low temperatures, low pressures, high winds, high or low humidity, fog, dust storms), the EPA has established sampler specifications that are intended to cover reasonably normal environmental conditions at about 95 percent of expected monitoring sites. Qualification test requirements in 40 CFR part 53 address most, if not all, of these operational requirements. Specification of the sampler performance for sites with extreme environmental conditions would substantially raise the cost of the sampler for other users, most of whom do not require the extra capability. Users requiring operation of samplers under extreme conditions are encouraged to develop supplemental specifications for modified samplers to cover those specific conditions. Sampler manufacturers have indicated a commitment to respond to the need for modified samplers for such extreme conditions.

Although concerns were expressed that the amount of data required to be reported from each sampler is excessive, EPA stresses that only a portion of the data collected by the sampler needs to be reported to AIRS. These limited data reporting requirements (i.e., ambient and filter temperature, barometric pressure, sample volume, variation in sample run flow rate) are important to establish or verify the reliability and confidence of the PM_{2.5} measurements and to aid in utilization of those data. The substantial amount of additional data generated by the sampler are of use to the site operator to provide confirmation of a given sample's validity, and to aid in troubleshooting should outlier measurements appear in the monitoring data. A variety of current electronic devices and systems may be used to acquire and handle the data, and these devices can easily accommodate the amount of data required to be reported, as well as the additional, optional data. Printers, modem connections, and

alternative data output connections or devices are not precluded.

4. *Additional changes.* Additional clarifying changes have also been made throughout 40 CFR part 50, Appendix L, based on comments received or recently obtained field test information. In 40 CFR part 50, Appendix L, section 3.1, the lower concentration of the method has been revised from 1 to 2 $\mu\text{g}/\text{m}^3$, based on the results of field blanks associated with available field test data. In 40 CFR part 50, Appendix L, section 3.3, the sample period specification has been augmented to clarify that a measured PM_{2.5} concentration for a sample period less than 23 hours that is greater than the NAAQS level(s) is to be considered a valid measurement for comparison to the NAAQS, even though not valid for other purposes. Sections 4 (Accuracy) and 5 (Precision) have been revised to properly reflect associated changes to the data quality and method performance assessment requirements set forth in 40 CFR part 58, Appendix A.

A provision has been added in 40 CFR part 50, Appendix L, section 7.4.17 to require sampler manufacturers to make available computer software to input sampler output data and translate the data into a standard spreadsheet format (since no specific format is specified for output of the sample data acquired by the sampler).

The requirements for the sampler to display current flow rate, temperature, filter temperature, and barometric pressure readings have been changed to require updating of these readings at least every 30 seconds. This change is based on operational experience of prototype samplers in 40 CFR part 50, Appendix L, section 7.4.5.1, and will make it easier for the operators to perform status checks and calibrations. In 40 CFR part 50, Appendix L, section 7.4.8.1, the requirements for the ambient temperature sensor have been changed to specify an external sensor with a passive sun shield, to provide better uniformity in the ambient temperature measurements among different types of reference method samplers. The reference method has also been clarified to indicate that PM_{2.5} samples for which the sampler reported an out-of-specification (FLAG) occurrence during or after the sample period are not necessarily invalid, and that such samples should be reviewed by a quality assurance officer (40 CFR part 50, Appendix L, section 10.12). Finally, a new reference has been added in section 13 of the Act to provide applicable standards for meteorological measurements and measurement systems.

5. *Decision on 40 CFR part 50, Appendix L.* After fully considering the public comments on the proposed new reference method for PM_{2.5}, EPA has concluded that the proposed design and performance specifications for the reference sampler, with the modifications discussed in this unit, will achieve the design objectives set forth in the

proposal and outlined above. Therefore, EPA is adopting the sampler and other method requirements specified in 40 CFR part 50, Appendix L as the reference method for measuring PM_{2.5} in the ambient air.

Since proposal, a series of field tests have been performed using prototype samplers manufactured in accordance with the proposed design and performance specifications. The results of these field tests confirm that the prototype samplers perform in accordance with design expectations. Operational experience gained through these field tests did, however, identify the need for minor modifications as discussed above in this unit. In addition, EPA made other modifications to the proposed design and performance specification in response to public comment as discussed above. As part of this process, EPA performed laboratory tests to ensure that the modifications achieved the intended objective.

While the results of these field tests and laboratory tests were largely confirmatory in nature and did not indicate a need to alter the basic design and performance specifications, they did identify areas that needed further refinement. Given that these tests were performed, by necessity, during and after the close of the public comment period and because the results were not available for placement in the docket until late in the rulemaking process, EPA is announcing, in a separate **Federal Register** notice being signed today, a supplemental comment period for the limited purpose of taking comments on these field and laboratory test results.

VII. Effective Date of the Revised PM Standards and Applicability of the Current PM₁₀ Standards

In summary, the primary and secondary NAAQS for PM have been revised by establishing annual and 24-hour PM_{2.5} standards; and by changing the form of the existing 24-hour PM₁₀ standards. The existing PM₁₀ annual standards have been retained. Section 50.3 (reference conditions) of 40 CFR part 50 has been revised to remove the adjustment of measured PM₁₀ concentrations to standard conditions of temperature and pressure with respect to the revised PM standards. (Although EPA is retaining the current annual PM₁₀ standards, the revision of 40 CFR 50.3 potentially may affect the effective stringency of the annual standards.) A new Appendix M has been added to 40 CFR part 50 that reflects the revision of 40 CFR 50.3. A new Appendix N to 40 CFR part 50 has been added to reflect the forms of the PM_{2.5} and revised PM₁₀ standards. Finally, a new Appendix L to 40 CFR part 50 has been added that specifies the reference method for measuring PM_{2.5} in the ambient air.

The revised PM NAAQS, the revisions to 40 CFR 50.3, and the new Appendices M, N, and L to 40 CFR part 50 will become effective September 16, 1997. Inherent in the establishment of this revised set of PM

standards and related provisions is the revocation of the current set of PM₁₀ standards and associated provisions. To provide for an effective transition from the existing PM standards to the revised PM standards—in light of the need to establish PM_{2.5} monitoring networks, designate areas, and develop control strategies for PM_{2.5}—the Administrator has determined that the effective date of the revocation of the current set of PM₁₀ standards and associated provisions should be delayed so that the existing standards and associated provisions will continue to apply for an interim period. The duration of the interim period would depend on whether the area in question has attained the current PM₁₀ standards, as described below in this unit.

First, section 172(e) of the Act provides that, if the Administrator relaxes a national primary ambient air quality standard, she shall, within 12 months after the relaxation, promulgate requirements applicable to all areas that have not attained that standard as of the date of the relaxation. Those requirements shall provide for controls that are not less stringent than the controls applicable to areas designated nonattainment before such relaxation. Although the set of revised PM standards, viewed as a whole, is more stringent than the set of current PM standards, it appears that the shift from the current PM₁₀ standards to the revised PM₁₀ standards, viewed in and of itself, represents a relaxation of the current PM₁₀ standards. As a result, section 172(e) of the Act requires EPA to issue a rule within 12 months to apply implementation requirements no less stringent than the currently applicable requirements for those areas that have not yet attained the current PM₁₀ standard(s) by today's promulgation. However, the Act does not specifically provide how to ensure that States with current PM₁₀ problems should maintain the necessary public health protection in the interim between promulgation of a relaxed standard and issuance of a rule under section 172(e) of the Act. For that reason, EPA believes that it is both necessary and appropriate to defer the effective date of the revocation of the current PM₁₀ standards, for areas that have not attained those standards, until EPA issues the rule called for by section 172(e) of the Act.

Second, since it will take many years for States to identify PM problems under the revised standards and to develop effective means for addressing those problems, EPA believes it is necessary for even those areas that have already attained the current PM₁₀ standards (and hence are not subject to the terms of section 172(e) of the Act) to continue their current PM₁₀ implementation efforts for the purpose of protecting public health in the transition to implementation of the revised standards.

In order to deal with both of these categories of areas—those that are not attaining the current PM₁₀ standards and

those that are in attainment of the current PM₁₀ standards—EPA is taking a two-pronged approach towards deferral of the effective date of the revocation of the current PM₁₀ standards. For those areas that are not attaining the current PM₁₀ standards at the time of the promulgation of the revised PM₁₀ standards, the current standards will continue to apply until EPA has completed its rulemaking under section 172(e) of the Act to prevent backsliding in those areas. This will assure that no backsliding can occur in the interim period between the promulgation of the revised standards and the completion of the rulemaking under section 172(e) of the Act. For those areas that are attaining the current PM₁₀ standards at the time of promulgation of the revised PM₁₀ standards, the existing PM₁₀ standards will continue to apply until the areas have an approved SIP that includes any control measures that had been adopted and implemented at the State level to meet the current PM₁₀ NAAQS and have an approved section 110 SIP for purposes of implementing the revised PM standards. If an area has already received approval of a PM₁₀ SIP embodying all of the measures that had been adopted and implemented at the State level, no further Part D submission or approval would be necessary. If an area has already submitted such measures, EPA would need to take action to approve them. Finally, if an area has not yet submitted such measures to EPA for inclusion in the SIP, the area would need to submit them and EPA would need to approve them. This submission and approval would serve to satisfy both the area's remaining subpart D obligations and, in part, its new obligations under section 110(a)(1) of the Act regarding the implementation of the revised PM NAAQS. EPA emphasizes that it is not requiring an approval of a modeled attainment demonstration for the current PM₁₀ NAAQS, only an approval of the control measures that had in fact been adopted and implemented and that, therefore, were responsible for the area's attainment of the current PM₁₀ standards.

The existing definition of reference conditions and 40 CFR part 50, Appendices J and K will remain in force as long as the current PM₁₀ standards apply to an area. Additional policies and guidance for assuring an effective transition will be set forth in future EPA guidance, policies, and/or rules.

VIII. Regulatory and Environmental Impact Analyses

As discussed in Unit IV of this preamble, the Clean Air Act and judicial decisions make clear that the economic and technological feasibility of attaining ambient standards are not to be considered in setting NAAQS, although such factors may be considered in the development of State plans to implement the standards. Accordingly, although, as described below, a Regulatory Impact Analysis (RIA) has been prepared, neither the

RIA nor the associated contractor reports have been considered in issuing this final rule.

A. Executive Order 12866

Under Executive Order 12866, 58 FR 51735 (October 4, 1993), the Agency must determine whether a regulatory action is "significant" and, therefore, subject to Office of Management and Budget (OMB) review and other requirements of the Executive Order. The order defines "significant regulatory action" as any regulatory action that is likely to result in a rule that may:

(1) Have an annual effect on the economy of \$100 million or more or adversely affect in a material way the economy, a sector of the economy, productivity, competition, jobs, the environment, public health or safety, or State, local, or tribal governments or communities.

(2) Create a serious inconsistency or otherwise interfere with an action taken or planned by another Agency.

(3) Materially alter the budgetary impact of entitlements, grants, user fees, or loan programs or the rights and obligations of recipients thereof.

(4) Raise novel legal or policy issues arising out of legal mandates, the President's priorities, or the principles set forth in the Executive Order.

In view of its important policy implications, this action has been judged to be a "significant regulatory action" within the meaning of the Executive Order. As a result, under section 6 of the Executive Order, EPA has prepared an RIA, entitled "Regulatory Impact Analysis for Particulate Matter and Ozone National Ambient Air Quality Standards and Proposed Regional Haze Rule (July 1997)." This RIA assesses the costs, economic impacts, and benefits associated with potential State implementation strategies for attaining the PM and O₃ NAAQS and the proposed Regional Haze Rule. Changes made in response to OMB suggestions or recommendations will be documented in the public docket and made available for public inspection at EPA's Air and Radiation Docket Information Center (Docket No. A-95-58). The RIA will be publicly available in hard copy by contacting the U.S. Environmental Protection Agency Library at the address under "Availability of Related Information" and in electronic form as discussed above in "Electronic Availability."

B. Regulatory Flexibility Analysis

The Regulatory Flexibility Act (RFA), 5 U.S.C. 601 *et seq.*, provides that, whenever an agency is required to publish a general notice of rulemaking for a proposal, the agency must prepare an initial regulatory flexibility analysis for the proposal unless the head of the agency certifies that the rule will not, if promulgated, have a significant economic impact on a substantial number of

small entities (section 605(b)). The EPA certified the proposed NAAQS rule based on its conclusion that the rule would not establish requirements applicable to small entities and therefore would not have a significant economic impact on small entities within the meaning of the RFA. See 61 FR 65638, 65668 (PM proposal) and 61 FR 65716, 65764 (ozone proposal), both published December 13, 1996. Accordingly, the Agency did not prepare an initial regulatory flexibility analysis for the proposal, but it did conduct a more general analysis of the potential impact on small entities of possible State strategies for implementing any new or revised NAAQS.

At the heart of EPA's certification of the proposed NAAQS rule was the Agency's interpretation of the word "impact" as used in the RFA. Is the "impact" to be analyzed under the RFA a rule's impact on the small entities that will be subject to the rule's requirements, or the rule's impact on small entities in general, whether or not they will be subject to the rule? In the case of NAAQS rules, the question arises because of the congressionally designed mixture of Federal and State responsibilities in setting and implementing the NAAQS.

As EPA explained in the proposal, NAAQS rules establish air quality standards that States are primarily responsible for meeting. Under section 110 and Part D of Title I of the Act, every State develops a State Implementation Plan (SIP) containing the control measures that will achieve a newly promulgated NAAQS. States have broad discretion in the choice of control measures. As the U.S. Supreme Court noted in *Train v. NRDC*, 421 U.S. 60 (1975), 95 S. Ct. 1470:

[P]rimary [NAAQS] deal with the quality of outdoor air and are fixed on a nationwide basis at a level which the agency determines will protect the public health. It is the attainment and maintenance of these standards which section 110(a)(2)(A) requires that State plans provide. In complying with this requirement, a State's plan must include "emission limitations" which are regulations of the composition of substances emitted into the ambient air from such sources as power plants, service stations and the like. They are the specific rules to which operators of pollution sources are subject and which, if enforced, should result in ambient air which meets the national standards.

The Agency is plainly charged by the Act with the responsibility for setting the national ambient air standards. Just as plainly, it is relegated to a secondary role in the process of determining and enforcing the specific, source-by-source emission limitations which are necessary if the national standards are to be met. Under 110(a)(2), the Agency is required to approve a State plan which provides for the timely attainment and maintenance of the ambient air standards, and which also satisfies that sections other general requirements. The Act gives the agency no authority to question the wisdom of a state's choices of emission limitations if they are part of a plan which satisfies the standards of 110(a)(2) and the Agency may devise and promulgate a plan of its own only if

the State fails to submit an implementation plan which satisfies those standards. Section 110(c).

421 U.S. 60 at 78-79 (emphasis in original). In short, NAAQS rules themselves do not establish any control requirements applicable to small entities. State rules implementing the NAAQS may establish such requirements and the extent to which they do depends primarily on each State's strategy for meeting the NAAQS.⁹⁵

To determine the proper interpretation of impact under the RFA, EPA considered the RFA's stated purpose, its requirements for regulatory flexibility analyses, its legislative history, the amendments made by the Small Business Regulatory Enforcement Fairness Act of 1996 (SBREFA) (Pub. L. 104-121), and caselaw. The EPA concluded that all of these traditional tools of statutory construction point in one direction—that an agency is required to assess the impact of a rule on the small entities that will be subject to the rule's requirements, because the purpose of a regulatory flexibility analysis is to consider ways of easing or even waiving a rule's requirements as they will apply to small entities, consistent with the statute authorizing the rule. That purpose cannot be served in the case of the rules like the NAAQS that do not have requirements that apply to small entities.

More specifically, EPA noted that its interpretation of "impact" flows from the express purpose of the RFA itself. As the RFA's "Findings and Purposes" section (Pub. L. 96-354, section 2) makes clear, Congress enacted the RFA in 1980 out of concern that agencies were writing one-size-fits-all regulations that in fact did not fit the size and resources of small entities. Congress noted that it is generally easier for big businesses to comply with regulations, and that small businesses are therefore at a competitive disadvantage in complying with uniform rules. Congress also noted that small entities' relative contribution to the problem a rule is supposed to solve may not warrant applying the same requirements to large and small entities alike. In the RFA itself, Congress therefore stated:

It is the purpose of this Act to establish as a principle of regulatory issuance that agencies shall endeavor, consistent with the objectives of the rule and of applicable statutes, to fit regulatory and informational requirements to the scale of the businesses, organizations, and governmental jurisdictions subject to regulation.

(Pub. L. 96-354, section 2(b))

The EPA further noted that the RFA sections governing initial and final regulatory

⁹⁵ It is worth noting that Federal rules that apply nationally also play a role in reducing emissions governed by NAAQS. For instance, EPA rules under Title II of the Act require reductions in ozone-forming emissions from on and off-road vehicles and the fuels that power them. When EPA issues such rules, it conducts the analysis required under the RFA. For example, EPA performed regulatory flexibility analyses for the reformulated gasoline rule issued under section 211(k) of the Act. See 59 FR 7716, February 16, 1994.

flexibility analyses reflect this statement of purpose. Sections 603 and 604 of the RFA require that initial and final regulatory flexibility analyses identify the types and estimate the numbers of small entities “to which the proposed will apply” (sections 603(b)(3) and 604(a)(3) of the RFA). Similarly, they require a description of the “projected reporting, recordkeeping, and other compliance requirements of the proposal, including an estimate of the classes of small entities which will be subject to the requirement” (sections 603(b)(4) and 604(a)(4)). At the core of the analyses is the requirement that agencies identify and consider “significant regulatory alternatives” that would “accomplish the stated objectives of applicable statutes and which minimize any significant economic impact of the proposal on small entities” (sections 603(c) and 604(a)(5)). Among the types of alternatives agencies are to consider are the establishment of different “compliance or reporting requirements or timetables” for small entities and the exemption of small entities “from coverage of the rule, or any part” of the rule (section 603(c)(1) and (4) of the RFA). The RFA thus makes clear that regulatory flexibility analyses are to focus on how to minimize rule requirements on small entities.

As EPA further explained, since regulatory flexibility analyses are not required for a rule that will not have a “significant economic impact on a substantial number of small entities”, it makes sense to interpret “impact” in light of the requirements for such analyses. Regulatory flexibility analyses, as described in this unit, are to consider how a rule will apply to small entities and how its requirements may be minimized with respect to small entities. In this context, “impact” is appropriately interpreted to mean the impact of a rule on the small entities subject to the rule’s requirements.

The Agency cited two Federal court cases in support of its interpretation. In *Mid-Tex Elec. Co-op v. FERC*, 773 F.2d 327, 342 (D.C. Cir. 1985), petitioners claimed that the RFA required an agency to analyze the effects of a rule on small entities that were not regulated by the rule but might be indirectly impacted by it. Petitioners noted that the Small Business Administration (SBA) also interpreted the RFA to require analysis of a rule’s impact on small entities not regulated by the rule, and argued that the court should defer to the SBA’s position in light of its compliance monitoring role under the RFA. After reviewing the RFA’s “Findings and Purposes” section, its legislative history, and its requirements for regulatory flexibility analyses, the Mid-Tex court rejected petitioners’ interpretation. As the court explained:

The problem Congress stated it discerned was the high cost to small entities of compliance with uniform regulations, and the remedy Congress fashioned—careful consideration of those costs in

regulatory flexibility analyses—is accordingly limited to small entities subject to the proposed regulation * * *. [W]e conclude that an agency may properly certify that no regulatory flexibility analysis is necessary when it determines that the rule will not have a significant economic impact on a substantial number of small entities that are subject to the requirements of the rule.

Id. at 342. Notably, Congress let this interpretation stand when it recently amended the RFA in enacting SBREFA.

The EPA also cited a recent case affirming the Mid-Tex court’s interpretation. In *United Distribution Companies v. FERC*, 88 F.3d 1105, 1170 (D.C. Cir. 1996), the court noted that the Mid-Tex court:

* * * conducted an extensive analysis of RFA provisions governing when a regulatory flexibility analysis is required and concluded that no analysis is necessary when an agency determines “that the rule will not have a significant economic impact on a substantial number of small entities that are subject to the requirements of the rule”.

Id., citing and quoting Mid-Tex (emphasis added by United Distribution court). The Agency went on to explain that given the Federal/State partnership for attaining healthy air, the proposed NAAQS, if adopted, would not establish any requirements applicable to small entities. Instead, any new or revised standard would establish levels of air quality that States would be primarily responsible for achieving by adopting plans containing specific control measures for that purpose. The proposed NAAQS rule was thus not susceptible to regulatory flexibility analysis as prescribed by the amended RFA. Since it would establish no requirements applicable to small entities, it afforded no opportunity for EPA to fashion for small entities less burdensome compliance or reporting requirements or timetables, or exemptions from all or part of the rule. For these reasons, EPA certified that the proposal “will not, if promulgated, have a significant economic impact on a substantial number of small entities,” within the meaning of the RFA. Because EPA was not required to prepare an initial regulatory flexibility analysis for the rule, it was also not required to convene a Small Business Advocacy Review Panel for the rule under section 609(b) of the RFA, as added by SBREFA.

Notwithstanding its certification of the proposal, EPA recognized that the proposed NAAQS, if adopted, would begin a process of State implementation that could eventually lead to small entities having to comply with new or different control measures, depending on the implementation plans developed by the States. EPA also recognized that the Act does not allow EPA to dictate or second-guess how States should exercise their discretion in regulating to attain any new or revised NAAQS. Under those circumstances, EPA concluded that the best way to take account of small entity concerns regarding any new or revised NAAQS was to work with small entity representatives and States to provide

information and guidance on how States could address small entity concerns when they write their implementation plans.

In line with this approach, as part of RIA it prepared for the proposed NAAQS, EPA analyzed how hypothetical State plans for implementing the proposal might affect small entities. The analysis was necessarily speculative and limited, since it depended on projections about what States might do several years in the future and did not take into account any new strategies that might be developed and recommended by the FACA subcommittee formed to help devise potential strategies for implementing a new or revised NAAQS (see discussion of RIA and FACA process in this document). Nevertheless, the analysis provided as much information on potential small entity impacts as was reasonably available at the time of the proposal.

The Agency also took steps to ensure that small entities’ voices were heard in the NAAQS rulemaking itself. With Jere Glover, Chief Counsel for Advocacy of the SBA, EPA convened outreach meetings modeled on the SBREFA panel process to solicit and convey small entities’ concerns with the proposed NAAQS. Two meetings were held as part of that process, on January 7 and February 28, 1997, with a total attendance of 41 representatives of small businesses, small governments, and small nonprofit organizations. Both meetings were attended by representatives of SBA and OMB, as well as of EPA. The key concerns raised by small entities at those meetings related to the scientific foundation of the proposed NAAQS and the potential cost of implementing it, the same concerns raised by other industry commenters on the proposal. The Agency produced a report on the meetings to ensure that small entity concerns were part of the rulemaking record when EPA made its final decision on the proposal.

In light of States’ pivotal role in NAAQS implementation, EPA also undertook a number of additional activities to assist and encourage the States to be sensitive to small entity impacts as they implement any new or revised NAAQS. With the SBA, EPA began an interagency panel process to collect advice and recommendations from small entity representatives on how States could lessen any impacts on small entities. The EPA plans to issue materials in two phases to help States develop their implementation plans. In view of States’ discretion in implementing the NAAQS, these materials will mostly take the form of guidance, which is not subject to the RFA’s requirement for initial regulatory flexibility analysis. (Under section 603 of the RFA, that requirement applies only to binding rules that are required to undergo notice and comment rulemaking procedures.) But regardless of the form such materials take, EPA is employing panel procedures to ensure that small entities have an opportunity to raise

any concerns prior to the materials being issued in draft form.

To supplement the input the Agency receives from the ongoing FACA process (described previously in this document), EPA also added more small entity representatives to the Subcommittee on implementation of any new or revised NAAQS. These representatives have formed a small entity caucus to develop and bring to the Subcommittee a focused approach to small entity issues. These new Subcommittee members are also part of the group in the aforementioned panel process. By means of these various processes, EPA hopes to promote the consideration of small entity concerns and advice throughout the NAAQS implementation process.

In response to the proposal, a number of commenters questioned EPA's decision to certify that the proposed NAAQS will not have a significant impact on a substantial number of small entities. Some commenters disagreed with EPA's view that the proposed NAAQS would not establish regulatory requirements applicable to small entities. These commenters argued that a number of control requirements applicable to small entities would automatically result from promulgation of the proposed NAAQS, such as new reasonable further progress, SIP and Federal Implementation Plan (FIP) requirements. Other commenters stated that it is possible for EPA to assess the impacts of the NAAQS revision on small entities and that, to a limited extent, EPA has already done so. Further, a number of commenters argued that EPA has a legal obligation under the RFA, as amended by SBREFA, to choose a NAAQS alternative that minimizes the impact on small entities. Some commenters questioned EPA's interpretations of the Mid-Tex and United Distribution cases. In addition, other commenters stated that EPA's position regarding the NAAQS and the RFA is inconsistent with its past practice and the legislative history of the RFA. Finally, a few commenters noted that the panel process EPA conducted for the proposed NAAQS did not satisfy the requirements of SBREFA.

EPA disagrees that promulgation of the NAAQS will automatically result in control requirements applicable to small entities that EPA can and must analyze under the RFA. As noted previously in this unit, a NAAQS rule only establishes a standard of air quality that other provisions of the Act call on States (or in case of State inaction, the Federal government) to achieve by adopting implementation plans containing specific control measures for that purpose. Following promulgation of a new or revised NAAQS, section 110 of the Act requires States and EPA to engage in a designation process to determine what areas within each State's borders are attaining or not attaining the NAAQS. Under section 110 and Parts C and D of Title I of the Act, States then conduct a planning process to develop and adopt their

SIPS. Depending on an area's designation for the particular NAAQS, these and other Title I provisions of the Act require a State's SIP to contain certain control programs in addition to the control measures that the State decides are also needed to attain and maintain the NAAQS.

The fact that the Act requires SIPs to contain certain control programs under certain circumstances does not mean that EPA either can or must conduct a regulatory flexibility analysis of a rule establishing a NAAQS. Just from the standpoint of feasibility, EPA cannot know which areas will be subject to what mandatory SIP programs until after the designation process is completed. Beyond that, any mandatory SIP programs are still implemented by the States, and States have considerable discretion in how they implement them. For instance, the reasonable further progress requirement under section 172 of the Act leaves States broad discretion to determine the rate of progress and the control measures to achieve that progress.⁹⁶ As a result, EPA cannot be certain where and how any mandatory programs will be implemented with respect to small (or large) entities. Much less can EPA know about how States will exercise their discretion to develop additional controls needed to attain and maintain the NAAQS.

Even if EPA could know exactly how any mandatory SIP programs would apply to small entities, the purpose of the RFA is not served by attempting a regulatory flexibility analysis of State implementation of those programs. As explained previously in this unit, the RFA and the caselaw interpreting it clearly establish that the purpose of the RFA is to promote Federal agency efforts to tailor a rule's requirements to the scale of the small entities that will be subject to it. That purpose cannot be served in the case of a NAAQS rule since the rule does not establish requirements applicable to small entities. In promulgating a NAAQS, the only choice before EPA concerns the level of the standard, not its implementation. While mandatory SIP programs may ultimately follow from promulgation of the NAAQS, there is nothing EPA can do in setting the NAAQS to tailor those programs as they apply to small entities. Whether and how the programs will apply in particular nonattainment areas is beyond the scope of the NAAQS rulemaking and, indeed, beyond EPA's reach in any rulemaking to the extent the applicability and terms of the programs are prescribed by statute.⁹⁷

⁹⁶The SIP requirements of subpart 4 of Part D of Title I of the Act apply to SIPs for areas designated as not attaining NAAQS for PM₁₀. Those requirements will not apply to SIPs to implement the PM_{2.5} NAAQS. Further, to the extent SIPs for areas in nonattainment with the applicable PM₁₀ NAAQS remain subject to subpart 4 requirements, there will be no incremental change in the impact on sources regulated by the States' SIPs pursuant to those requirements as a result of this promulgation.

⁹⁷If and when the Agency issues any rules addressing State implementation of any statutorily required actions,

Moreover, any mandatory SIP programs are supplemented by discretionary State controls that EPA has no power to tailor under the RFA or the Act (see *Train v. NRDC*, quoted previously in this unit).

The commenters' suggestions for minimizing the potential impact of the NAAQS rule on small entities run afoul of both the RFA and the Act. Some suggested that EPA set a less stringent standard (or no standard at all in the case of PM_{2.5}) to reduce the chance that small entities would become subject to new or tighter SIP requirements. Others suggested that EPA require States to exempt small entities from new or tighter SIP requirements. However, as explained previously in this document, the RFA neither requires nor authorizes EPA to set a less stringent NAAQS than the applicable Clean Air Act provisions allow in order to reduce potential small entity impacts. Indeed, the RFA provides that any means of providing regulatory flexibility to small entities be consistent with the statute authorizing the rule. Moreover, even if EPA set a less stringent standard, States could still exercise their discretion to obtain any needed emission reductions from small entities. As the Supreme Court in *Train v. NRDC* made clear, EPA has no authority to forbid States from obtaining reductions from any particular category of stationary sources, including small entities. See also, *Virginia v. EPA*, No. 108 F.3d 1397, 1408 (D.C. Cir. 1997), quoting *Union Electric v. EPA*, 427 U.S. 246, 269 (1976) ("section 110 left to the states the power to determine which sources would be burdened by regulations and to what extent").

EPA's approval of SIPs for the new or revised NAAQS also will not establish new requirements, but will instead simply approve requirements that a State is already imposing. And again, EPA does not have authority to disapprove a State's plan except to the extent that the plan fails to demonstrate attainment and maintenance of the NAAQS as required by Title I of the Clean Air Act. In cases where EPA promulgates a FIP, EPA might establish control requirements applicable to small entities, and in such a circumstance, EPA would conduct the analyses required by the RFA.

Some commenters argued that under the RFA as amended by SBREFA, EPA now has an obligation to choose the alternative that minimizes the impact on small entities when setting the NAAQS. As indicated previously in this unit, EPA disagrees with the commenters' argument for the reasons stated in this document's discussion of the Agency's authority to consider costs and other factors not related to public health in setting and revising primary NAAQS. In a nutshell, both the text and legislative history of the RFA make clear that the RFA does not override the substantive provisions of the statute

EPA would analyze and address the impact of those rules on small entities as appropriate under the RFA.

authorizing the rule, but only requires agencies to identify and consider ways of minimizing the economic impact on small entities subject to the rule in a manner consistent with the authorizing statute.

Some commenters disagreed with EPA's interpretation of the Mid-Tex and United Distribution cases. In particular, these commenters noted that in those cases the relevant regulatory agency, Federal Energy Regulatory Commission (FERC), wholly lacked jurisdiction to regulate the small entities at issue. According to these commenters, EPA does have the ability and jurisdiction to regulate small entities in the case of the NAAQS, and therefore EPA's reliance on Mid-Tex and United Distribution is misplaced.

The commenters' attempt to distinguish the FERC cases from the NAAQS rulemaking wholly overlooks the courts' reasoning, which in fact fully supports EPA's certification of the proposed NAAQS. As described previously in this unit, the Mid-Tex court exhaustively reviewed the relevant sections of the RFA and its legislative history. Its analysis revealed that Congress passed the RFA out of concern with one-size-fits-all regulations and fashioned a remedy limited to regulations that apply to small entities. This principle is fully applicable to the NAAQS, which creates no rule requirements that apply to small entities.

The fact that FERC had no regulatory authority over the small entities indirectly affected by its rules played no essential role in the court's rationale. FERC could (and apparently did in the Mid-Tex rulemaking) estimate the potential indirect impact of its rules on small entities. Presumably, FERC could have also mitigated any indirect impact by changing some aspect of the rule (or else the small entities would have had no incentive to sue the agency). The court nevertheless found it unnecessary for FERC to do either, based on its reading of the RFA as limited to analysis of a rule's impact on the small entities subject to the rule's requirements. In reaching its decision, the court noted that requiring agencies to "consider every indirect effect that any regulation might have on small businesses * * * is a very broad and ambitious agenda, * * * that Congress is unlikely to have embarked on * * * without airing the matter." Mid-Tex, 773 F.d. at 343.

The commenters also overstate EPA's regulatory authority over small entities with respect to the regulation of criteria pollutants. Various provisions of the Clean Air Act authorize EPA to regulate various types of sources at the Federal level to accomplish specified goals. However, EPA's authority to more generally regulate sources, including small entities, in the manner of SIPs is limited to instances of State default of SIP responsibilities. When that occurs, EPA may issue a FIP containing specific control measures, and to the extent a proposed FIP

would establish control measures applicable to small entities, EPA would analyze the small entity impact of those measures as required by the RFA. In 1994, for example, EPA prepared an initial regulatory flexibility analysis when it proposed a FIP for Los Angeles. See 59 FR 23264 (May 5, 1994).

As noted previously in this unit, Congress let the Mid-Tex interpretation stand when it recently amended the RFA in enacting SBREFA. If it had disagreed with the court's decision, it would have revised the relevant statutory provisions or otherwise indicated its disagreement when it enacted SBREFA. Instead, Congress actually reinforced the Mid-Tex court's interpretation of the RFA in enacting section 212(a) of SBREFA. That section requires that an agency issue a "small entity compliance guide" for "each rule * * * for which an agency is required to prepare a final regulatory flexibility analysis under section 604" of the RFA. The guide is "to assist small entities in complying with the rule" by "explain[ing] the actions a small entity is required to take to comply" with the rule (section 212(a) of SBREFA). Obviously, it makes no sense to prepare a small entity compliance guide for a rule that does not apply to small entities. Thus SBREFA stands as further confirmation that Congress intended the RFA to address only rules that establish requirements small entities must meet. Since SBREFA's passage, the United Distribution court has affirmed the Mid-Tex court's interpretation.

Some commenters noted that EPA's informal panel process did not comply with the requirements of SBREFA. The EPA did not convene a SBREFA panel because such a panel is not required for rules like the NAAQS that do not apply to small entities. Under the RFA as amended by SBREFA, since the Agency certified the proposal, it was not required to convene a panel for it. Nevertheless, EPA conducted the voluntary panel process described previously in this unit, as well as other voluntary small business outreach efforts. The process could not comply with the analytical requirements of the RFA for the reasons given in this unit. However, it could and did ensure that EPA heard directly from small entities about the NAAQS proposals.

A few commenters stated that EPA's view of the NAAQS and the RFA is inconsistent with EPA's past positions regarding the RFA and NAAQS revisions. Some commenters also cited the RIA for the proposed NAAQS and noted that this analysis demonstrates EPA's ability to estimate the impact of the NAAQS on small entities, thereby undercutting EPA's argument that it is not able to perform a regulatory flexibility analysis when setting the NAAQS.

Past Federal Register documents make clear that the nature of the NAAQS makes a regulatory flexibility analysis inapplicable to NAAQS rulemakings. For instance, in 1984, EPA stated that a "NAAQS for NO_x by itself

has no direct impact on small entities. However, it forces each State to design and implement control strategies for areas not in attainment." See 49 FR 6866, 6876 (February 23, 1984); see also, 50 FR 37484, 37499 (September 13, 1985); 50 FR 25532, 25542 (June 19, 1985) (NAAQS for NO₂ do not impact small entities directly). EPA stated again in 1987 that the NAAQS "themselves do not contain emission limits or other pollution controls. Rather, such controls are contained in state implementation plans." See 52 FR 24634, 24654 (July 1, 1987).

EPA has typically performed an analysis to assess, to the extent practicable, the potential impact of retaining or revising the NAAQS on small entities, depending on possible State strategies for implementing the NAAQS. These analyses have provided as much insight into the potential small entity impacts of implementing revised NAAQS as could be provided at the NAAQS rulemaking stage. In some instances, these preliminary analyses were described as "regulatory flexibility analysis[es]" or as analyses "pursuant to this [Regulatory Flexibility] Act." See, e.g., 52 FR 24634, 24654 (July 1, 1987); 50 FR 37484, 37499 (September 13, 1985).

However, these analyses were based on hypothetical State control strategies, and EPA made the point on various occasions that any conclusions to be drawn from such analyses were speculative, given that the NAAQS themselves do not impose requirements on small entities. Although these past analyses reflected the Agency's best efforts to evaluate potential impacts, they were not regulatory flexibility analyses containing the necessary elements required by the RFA. These analyses, for example, did not describe the reporting, recordkeeping, and other compliance requirements of the proposed NAAQS rules that would apply to small entities, since the NAAQS rules did not apply to small entities. Nor did they determine how the proposed NAAQS rules could be eased or waived for small entities. Such an analysis is not possible in the case of the NAAQS. To the extent EPA labeled these analyses regulatory flexibility analyses in the past, that label was inappropriate. EPA's current practice is to describe such an analysis more accurately as a general analysis of the potential cost impacts on small entities. See, e.g., 61 FR 65638, 65669, 65747 (December 13, 1996) (current O₃ and PM NAAQS proposals).⁹⁸ EPA's analytical approach to

⁹⁸ As commenters pointed out, the RIA for the proposed PM NAAQS does state that "[t]he screening analysis * * * provides enough information for an initial regulatory flexibility analysis (RFA) if such an analysis were to be done." That statement was mistaken and was not made in the RIA for the proposed ozone NAAQS. While both RIAs attempted to gauge the potential impact on small entities of State implementation of the proposed NAAQS, neither could or did identify any specific control or information requirements contained in the NAAQS rule that would apply to small entities. Indeed, both RIAs made clear that the impact being analyzed was that of potential

small entity impacts of the NAAQS has thus remained consistent over time.

One commenter noted that the legislative history of the RFA suggests that the RFA was intended to apply to the NAAQS. As noted previously in this unit, EPA's reading of both the RFA and SBREFA, based on the language of the statute as amended and its legislative histories and applicable caselaw, is that the RFA requirements at issue do not apply to the NAAQS. The legislative history cited by the commenter does not change this conclusion.

In fact, the statement by Senator Culver on which the commenter relies does not indicate that the NAAQS should be subject to regulatory flexibility analyses. Rather, Senator Culver uses the NAAQS as an example of the type of standard that agencies would not change as a result of the RFA.

According to Senator Culver, section 606 of the RFA "succinctly states that this bill does not alter the substantive standard contained in underlying statutes which defines the agency's mandate." 126 Cong. Rec. S 21455 (August 6, 1980) daily ed. After citing section 109 of the Act, Senator Culver goes on to describe EPA's bubble policy (which addresses the limits on emissions from a particular facility) as the type of flexible regulation that agencies should consider, once EPA has set a NAAQS. "The important point for purposes of this discussion is that the 'bubble concept,' a type of flexible regulation, in no manner altered the basic statutory substantive standard of the EPA * * *. No regulatory flexibility analysis alters the substantive standard otherwise applicable by law to agency action." *Id.* Thus, contrary to the suggestion of the commenter, Senator Culver's statement actually confirms that the time to consider regulatory flexibility is when regulations applicable to sources are being established, not when a NAAQS itself is being set.

Under section 604 of the RFA, whenever an agency promulgates a final rule under section 553 of the Administrative Procedure Act, after being required by that section or any other law to publish a general notice of proposed rulemaking (NPRM), the agency is required to prepare a final regulatory flexibility analysis. RFA section 605(b) provides, however, that section 603 (re initial regulatory flexibility analyses) and section 604 do not apply if the agency certifies that the rule will not have a significant economic impact on a substantial number of small entities and publishes such certification at the time of publication of the NPRM or at the time of the final rule.

As noted above, EPA certified this final rule at the time of the NPRM. After considering the public comments on the

State measures to attain the NAAQS, and that such an analysis was inherently speculative and uncertain. Thus, the RIAs actually confirm EPA's statement in the preambles for the proposed NAAQS that conducting a complete regulatory flexibility analysis is not feasible for rules setting or revising a NAAQS.

certification, EPA continues to believe that this final rule will not have a significant economic impact on a substantial number of small entities for the reasons explained above and that it therefore appropriately certified the rule. Further, as required by the Clean Air Act, EPA is promulgating this final rule under section 307(d) of the Clean Air Act. For all the foregoing reasons, EPA has not prepared a final regulatory flexibility analysis for the rule. The Agency has nonetheless analyzed in the final RIA for the rule the potential impact on small entities of hypothetical State plans for implementing the NAAQS. The Agency also plans to issue guidance to the States on reducing the potential impact on small entities of implementing the NAAQS.

C. Impact on Reporting Requirements

There are no reporting requirements directly associated with the finalization of ambient air quality standards under section 109 of the Act (42 U.S.C. 7400). There are, however, reporting requirements associated with related sections of the Act, particularly sections 107, 110, 160, and 317 (42 U.S.C. 7407, 7410, 7460, and 7617).

In EPA's final revisions to the air quality surveillance requirements (40 CFR part 58) for PM, the associated RIA addresses the Paperwork Reduction Act requirements through an Information Collection Request.

D. Unfunded Mandates Reform Act

Title II of the Unfunded Mandates Reform Act of 1995 (UMRA), Pub. L. 104-4, establishes requirements for Federal agencies to assess the effects of certain regulatory actions on State, local, and tribal governments and the private sector. Under section 202 of UMRA, EPA generally must prepare a written statement, including a cost-benefit analysis, for proposed and final rules with "Federal mandates" that may result in expenditures by State, local, and tribal governments, in the aggregate, or by the private sector, of \$100 million or more in any 1 year. This requirement does not apply if EPA is prohibited by law from considering section 202 of UMRA estimates and analyses in adopting the rule in question. Before promulgating a final rule for which a written statement is needed, section 205 of UMRA generally requires EPA to identify and consider a reasonable number of regulatory alternatives and adopt the least costly, most cost-effective, or least burdensome alternative that achieves the objectives of the rule. These requirements do not apply when they are inconsistent with applicable law. Moreover, section 205 of UMRA allows EPA to adopt an alternative other than the least costly, most cost-effective, or least burdensome alternative if the Administrator publishes with the final rule an explanation of why that alternative was not adopted. Before EPA establishes any regulatory requirements that may significantly or uniquely affect small governments, including tribal governments, it must have

developed under section 203 of UMRA a small government agency plan. The plan must provide for notifying potentially affected small governments, enabling officials of affected small governments to have meaningful and timely input in the development of EPA regulatory proposals with significant Federal intergovernmental mandates, and informing, educating, and advising small governments on compliance with the regulatory requirements. Section 204 of UMRA requires each agency to develop "an effective process to permit elected officers of state, local and tribal governments * * * to provide meaningful and timely input" in the development of regulatory proposals containing a significant Federal intergovernmental mandate.⁹⁹

The EPA has determined that the provisions of sections 202 and 205 of UMRA do not apply to this decision. "Unless otherwise prohibited by law," EPA is to prepare a written statement under section 202 of UMRA that is to contain assessments and estimates of the costs and benefits of a rule containing a Federal mandate. Congress clarified that "unless otherwise prohibited by law" referred to whether an agency was prohibited from considering the information in the rulemaking process, not to whether an agency was prohibited from collecting the information. The Conference Report on UMRA states, "This section [202] does not require the preparation of any estimate or analysis if the agency is prohibited by law from considering the estimate or analysis in adopting the rule." 141 Cong. Rec. H3063 (daily ed. March 13, 1995). Because the Clean Air Act prohibits EPA, when setting the NAAQS, from considering the types of estimates and assessments described in section 202 of UMRA, UMRA does not require EPA to prepare a written statement under section 202.¹⁰⁰ The requirements in section 205 of UMRA do not apply because those requirements only apply to rules "for

⁹⁹ As noted in unit VIII.B., a NAAQS rule only establishes a standard of air quality that other provisions of the Act call on States (or in the case of State inaction, the Federal government) to achieve by adopting implementation plans containing specific control measures for the purpose. Thus, it is questionable whether the NAAQS itself imposes an enforceable duty and thus whether it is a significant Federal mandate within the meaning of UMRA. EPA need not and does not reach this issue in this document. For the reasons given in this unit, even if the NAAQS were determined to be a significant Federal mandate, EPA does not have any obligations under sections 202 and 205 of UMRA, and EPA has met any obligations it would have under section 204 of UMRA.

¹⁰⁰ In addition to the estimates and assessments described in section 202 of UMRA, written statements are also to include an identification of the Federal law under which the rule is promulgated (section 202(a)(1) of UMRA) and a description of outreach efforts under section 204 of UMRA (section 202(a)(5) of UMRA). Although these requirements do not apply here because a written statement is not required under section 202 of UMRA, this preamble identifies the Federal law under which this rule is being promulgated and a written statement describing EPA's outreach efforts with State, local, and tribal governments will be placed in the docket.

which a written statement is required under section 202 * * *.''

The EPA has determined that the provisions of section 203 of UMRA do not apply to this decision. Section 203 of UMRA only requires the development of a small government agency plan for requirements with which small governments might have to comply. Since setting the NAAQS does not establish requirements with which small governments might have to comply, section 203 of UMRA does not apply. The EPA acknowledges, however, that any corresponding revisions to associated SIP requirements and air quality surveillance requirements, 40 CFR parts 51 and 58, respectively, might result in such effects. Accordingly, EPA did address unfunded mandates when it proposed revisions to 40 CFR part 58, and will do so, as appropriate, when it proposes any revision to 40 CFR part 51.

With regard to the outreach described in section 204 of UMRA, EPA did follow a process for providing elected officials with an opportunity for meaningful and timely input into the proposed NAAQS revisions, although EPA did not describe this process in the proposal. The EPA conducted a series of pre-proposal outreach meetings with State and local officials and their representatives that permitted these officials to provide meaningful and timely input on issues related to the NAAQS and the monitoring issues associated with them. Beginning in January, 1996, EPA briefed State and local air pollution control officials at national meetings with State and Territorial Air Pollution Program Administrators (STAPPA) / Association of Local Air Pollution Control Officials (ALAPCO) in Washington, DC, North Carolina, Chicago, and Nevada. The EPA also held briefings for the Washington, DC representatives of several State and local organizations, including National Conference of State Legislators, U.S. Conference of Mayors, National Governors Association, National League of Cities, and STAPPA/ALAPCO. EPA also held separate briefings and discussions with State and local officials at meetings set up by the National Governors Association, the U.S. Conference of Mayors and the Council of State Governments. The EPA also conducted in-depth briefings at each EPA regional office and regional staff also had several meetings and discussions with their State counterparts about the standards. The efforts described in this paragraph of this preamble, which provided elected officials with opportunity for meaningful and timely input into the proposed NAAQS revisions, met any requirements imposed by section 204 of UMRA. The docket will contain a written statement describing these outreach efforts, including a summary of the comments and concerns presented by State, local, and tribal governments and a summary of EPA's evaluation of those comments and concerns.

Several commenters disagreed with EPA that sections 202, 203, and 205 of UMRA do not apply to this decision. These commenters argued that EPA is not prohibited from considering costs in setting NAAQS under the Clean Air Act and applicable judicial decisions. Some commenters also expressed the view that there is no conflict between UMRA and the Clean Air Act with regard to the NAAQS. These commenters argued that UMRA and the NAAQS can be harmonized by reading UMRA as an information gathering statute and that EPA should therefore perform the analyses required by UMRA, regardless of whether costs may be considered. Finally, at least one commenter argued that in past NAAQS reviews, EPA did not dispute its UMRA obligations.

As discussed more fully in Unit IV. of this preamble, EPA is prohibited from considering cost in setting the NAAQS. Given that fact (as noted in Unit IV. of this preamble), sections 202 and 205 of UMRA do not apply.¹⁰¹ As the Conference Report clarifies, UMRA itself states that the section 202 estimates and analyses are not required in cases such as the NAAQS, where an agency is prohibited by law from considering section 202 estimates and analyses. Reading UMRA in the manner suggested by the commenters would effectively read this provision out of UMRA; UMRA contains an exception for rules like the NAAQS, it must be given effect.

With regard to EPA's position regarding UMRA in previous NAAQS review exercises, EPA simply made plain in those situations that because it did not plan on revising the NAAQS, it determined, without further review, that sections 202, 203, and 205 of UMRA did not apply. EPA thus stated that:

Because the Administrator has decided not to revise the existing primary NAAQS for SO₂, this action will not impose any new expenditures on governments or on the private sector, or establish any new regulatory requirements affecting small governments. Accordingly, EPA has determined that the provisions of sections 202, 203 and 205 do not apply to this final decision.

61 FR 25566, 25577, May 22, 1996; see also 61 FR 52852, 52856, October 8, 1996 (Same statement for NO₂ NAAQS). As this statement makes clear, EPA only determined that sections 202, 203, and 205 of UMRA did not apply to the NAAQS when EPA fails to

¹⁰¹ One commenter argued that in reviewing the SO₂ NAAQS, EPA determined that it need not revise the SO₂ NAAQS, but could instead pursue an alternative regulatory program under other authority. This commenter argued that EPA has similar flexibility in reviewing the PM and Ozone NAAQS, and thus UMRA requires EPA to identify the least burdensome alternative (such as retaining the current NAAQS) as part of that process. As discussed more fully in Unit IV. of this preamble, EPA does not agree that it has flexibility to choose such an alternative; nor does EPA agree with the commenter's characterization of the action it took in deciding not to revise the SO₂ NAAQS. In fact, in deciding not to revise the SO₂ NAAQS, EPA determined, for reasons independent of section 303 of the Clean Air Act that a NAAQS revision was not warranted. See 61 FR 25566, 25575 (May 22, 1996).

revise the standard. Having made that determination, EPA had no reason to catalog additional bases for finding UMRA inapplicable. Nothing in that statement was intended to preclude EPA, or precludes EPA, from concluding for other reasons (such as those discussed in this unit) that UMRA also does not apply when EPA in fact revises an applicable NAAQS.

E. Environmental Justice

Executive Order 12848 (58 FR 7629, February 11, 1994) requires that each Federal agency make achieving environmental justice part of its mission by identifying and addressing, as appropriate, disproportionately high and adverse human health or environmental effects of its programs, policies, and activities on minorities and low-income populations. These requirements have been addressed to the extent practicable in the RIA cited in this unit.

F. Submission to Congress and the Comptroller General

Under 5 U.S.C. 801(a)(1)(A), as added by the Small Business Regulatory Enforcement Fairness Act of 1996 (SBREFA), EPA submitted a report containing this rule and other required information to the U.S. Senate, the U.S. House of Representatives, and the Comptroller General of the United States prior to publication of the rule in this issue of the **Federal Register**. This rule is a "major rule" for purposes of SBREFA.

IX. Response to Petition for Administrator Browner's Rescusal

On March 13, 1997, the Washington Legal Foundation (WLF), filed a petition with EPA asking that I, Carol Browner, disqualify myself in rulemaking regarding the NAAQS for PM and ozone. The petition claims that my public statements indicate a "clear and convincing showing" that I had "already decided to revise the NAAQS for PM and ozone" and that I therefore "could not give meaningful consideration" to comments adverse to the proposed rule. On May 12, 1997, EPA's General Counsel, Jonathan Z. Cannon, sent a letter to WLF regarding the petition. This letter and the WLF petition were then placed in the dockets for the proposed ozone and PM standards pending "consideration and final response in connection with the Agency's final actions."

Contrary to WLF's assertions, I have maintained an open mind throughout these proceedings, and have based today's decisions on the rulemaking record—including consideration of comments opposed to the proposal. The law does not require the Administrator of EPA to disqualify herself merely for expressing views on a proposed regulation; in fact, it is part of my responsibility to engage in the public debate on the proposals. Moreover, the assertions in WLF's petition do not accurately represent my views. The petition takes quotes out of

context and repeatedly misinterprets my statements. For example, WLF quotes a statement that I made at the Children's Environmental Health Network Research Conference as an indication that I had "prejudged the issue." However, my statement that "I will not be swayed" did not refer to adopting the NAAQS as proposed. Instead, as is clear from reviewing the entire speech, I was addressing my broader concern about children's health and the range of EPA standards affecting children's health. I also appeared at several congressional hearings and testified before members of Congress, some of whom were strongly opposed to the proposals. At those hearings, I explained the reasons why I concluded the proposals were appropriate, given the information before me at the time. At the same time, I made clear that I took very seriously my obligation to keep an open mind, and to consider fully and fairly all significant comments that the Agency received. For these reasons and others, as set forth in Mr. Cannon's May 12, 1997 response to WLF, which I adopt in full, I have decided not to recuse myself from any aspect of considering revisions to the NAAQS for ozone and PM. Accordingly, I am hereby denying WLF's petition.

X. References

- (1) Abbey, D.E.; Mills, P.K.; Petersen, F.F.; Beeson, W.L. (1991) Long-term ambient concentrations of total suspended particulates and oxidants as related to incidence of chronic disease in California Seventh-Day Adventists. *Environmental Health Perspectives* 94:43-50.
- (2) Abt Associates (1996a) Proposed Methodology for PM Risk Analyses in Selected Cities (Draft). Prepared by Abt Associates, Inc., Hampden Square, Suite 500, 4800 Montgomery Lane, Bethesda, MD 20814-5341. February 12, 1996.
- (3) Abt Associates (1996b) A Particulate Matter Risk Analysis for Philadelphia and Los Angeles. Prepared by Abt Associates for US EPA, OAQPS, Hampden Square, Suite 500, 4800 Montgomery Lane, Bethesda, MD 20814-5341. July 3, 1996 (Updated November 1996).
- (4) Abt Associates (1997a) Revision of Mortality Incidence Estimates Based on Pope et al. (1995) in the Abt Particulate Matter Risk Assessment Report. Prepared by Abt Associates, Inc., Hampden Square, Suite 500, 4800 Montgomery Lane, Bethesda, MD 29814-5341. June 5, 1997.
- (5) Abt Associates (1997b) Revision of Mortality Incidence Estimates Based on Pope et al. (1995) in the Abt Particulate Matter Risk Assessment Report. Prepared by Abt Associates, Inc., Hampden Square, Suite 500, 4800 Montgomery Lane, Bethesda, MD 29814-5341. June 6, 1997.
- (6) American Industrial Health Council. (1997) Comments on EPA's Proposed Rule for National Ambient Air Quality Standards for Particulate Matter. Docket No. A-95-54, IV-D-2340. March 3, 1997.
- (7) American Petroleum Institute. (1997) Comments of the American Petroleum Institute on the Proposed National Ambient Air Quality Standards for Particulate Matter. Docket No. A-95-54, IV-D-2247. March 12, 1997.
- (8) Borja-Aburto, V.H.; Loomis, D.P.; Bangdiwala, S.I.; Shy, C.M.; Rascon-Pacheco, R.A. (1997) Ozone, suspended particulates, and daily mortality in Mexico City. *American Journal of Epidemiology* 145:258-268.
- (9) Braun-Fahrlander, C.; Ackermann-Liebrich, U.; Schwartz, J.; Gnehm, H.P.; Rutishauser, M.; Wanner, H.U. (1992) Air pollution and respiratory symptoms in preschool children. *American Review of Respiratory Disease* 145:42-47.
- (10) Brown, K. (1997) Predictability of personal exposure to airborne particulate matter from ambient concentrations in four communities. In: Comments of the American Petroleum Institute on the proposed national ambient air quality standards for particulate matter (Appendix F). Docket No. A-95-54, IV-D-2247.
- (11) California Environmental Protection Agency. (1997) Comments on the proposed national ambient air quality standards. Docket No. A-95-54, IV-D-2251. March 11, 1997.
- (12) Chestnut, L.G.; Rowe, R.D. (1990) Preservation values for visibility in the national parks. Washington, DC: U.S. Environmental Protection Agency.
- (13) Chestnut, L.G.; Dennis, R.L.; Latimer, D.A. (1994) Economic benefits of improvements in visibility: acid rain provisions of the 1990 Clean Air Act Amendments. Proceedings of the aerosols and atmospheric optics: radiative balance and visual air quality. Air & Waste Management International Specialty Conference, pp. 791-802.
- (14) Cooper, J.A.; Tawney, C.W. (1996) Comments on Office of Air Quality Planning and Standards recommended PM_{2.5} concentrations equivalent to current PM₁₀ standards. In: Comments of the American Iron and Steel Institute. Docket No. A-95-54, IV-D-2242. March 12, 1997.
- (15) Costa, D.L.; Dreher, K.L. (1997) Bioavailable transition metals in particulate matter mediate cardiopulmonary injury in healthy and compromised animal models. *Environmental Health Perspectives* (In press)
- (16) Damberg, R.; Polkowsky, B. (1996) Methodology for Estimating Visibility Improvements Due to Reductions in Fine Particle Concentrations. Memorandum to the docket for the PM National Ambient Air Quality Standards review. September 1996.
- (17) Davis, J.M.; Sacks, J.; Saltzman, N.; Smith, R.L.; Styer, P. (1996) Airborne particulate matter and daily mortality in Birmingham, Alabama. Technical Report #55, National Institute of Statistical Sciences, P.O. Box 14162, Research Triangle Park, NC 27709.
- (18) Delfino RJ, Murphy-Moulton AM, Burnett RT, Brook JR, Becklake MR. (1997) Effects of air pollution on emergency room visits for respiratory illnesses in Montreal, Quebec. *American Journal of Respiratory and Critical Care Medicine* 155:568-576
- (19) Dickey, J.H. (1997) Letter to President Bill Clinton. Docket No. A-95-54, IV-D-2301. March 12, 1997.
- (20) Dockery, D.W.; Cunningham, J.; Damokosh, A.L.; Neas, L.M.; Spengler, J.D.; Koutrakis, P.; Ware, J.H.; Raizenne, M.; Speizer, F.E. (1996) Health effects of acid aerosols on North American children: respiratory symptoms. *Environmental Health Perspectives* 104:500-505.
- (21) Dockery, D.W.; Pope, C.A., III; Wu, W.; Spengler, J.D.; Ware, J.H.; Fay, M.E.; Ferris, B.G., Jr.; Speizer, F.E. (1993) An association between air pollution and mortality in six U.S. cities. *New England Journal of Medicine* 329:1753-1759.
- (22) Dockery, D.W.; Schwartz, J.; Spengler, J.D. (1992) Air pollution and daily mortality: associations with particulates and acid aerosols. *Environmental Research* 59:362-373.
- (23) Dockery, D.W.; Speizer, F.E.; Stram, D.O.; Ware, J.H.; Spengler, J.D.; Ferris, B.G., Jr. (1989) Effects of inhalable particles on respiratory health of children. *American Review of Respiratory Disease* 139:587-594
- (24) Fairley, D. (1990) The relationship of daily mortality to suspended particulates in Santa Clara County, 1980-86. *Environmental Health Perspectives* 89:159-168.
- (25) Fitz-Simons, T.; Mintz, D.; Wayland, M. (1996) Proposed methodology for predicting PM_{2.5} from PM₁₀ values to assess the impact of alternative forms and levels of the PM National Ambient Air Quality Standards. Document transmitted to members of the Clean Air Act Scientific Advisory Committee on June 26, 1996.
- (26) Freas, W.P. (1997) Memorandum to the files: Ratios of Particulate Matter Annual Arithmetic Mean to Annual Geometric Mean Concentrations. Docket No. A-95-54, IV-B-2. May 29, 1997.
- (27) Friedlander, S.K. (1982) Letter from Sheldon K. Friedlander, Chair, Clean Air Science Advisory Committee to Administrator Anne. M. Gorsuch. Clean Air Scientific Advisory Committee Review and Closure of the Office of Air Quality Planning and Standards Staff Paper for Particulate Matter. January 29, 1982.
- (28) Gamble, J.F.; Lewis, R.J. (1996) Health and respirable particulate (PM₁₀) air pollution: a causal or statistical association? *Environmental Health Perspectives* 104:838-850.
- (29) Grand Canyon Visibility Transport Commission (1996) Recommendations for improving Western vistas. Report of the Grand Canyon Visibility Transport Commission to the U.S. Environmental Protection Agency. June 1996.
- (30) Godleski, J.J.; Sioutas, C.; Katler, M.; Catalano, P.; Koutrakis, P. (1996) Death from inhalation of concentrated ambient air particles in animal models of pulmonary disease. Proceedings of the Second Annual Colloquium on Particulate Air Pollution and Human Health. Lee, J.; Phalen, R.; eds. 4:136-143.
- (31) Gordian, M.E.; Ozkaynak, H.; Xue, J.; Morris, S.S.; Spengler, J.D. (1996) Particulate air pollution and respiratory disease in Anchorage, Alaska. *Environmental Health Perspectives* 104:290-297.
- (32) Hefflin, B.J.; Jalaludin, B.; McClure, E.; Cobb, N.; Johnson, C.A.; Jecha, L.; Etzel, R.A. (1994) Surveillance for dust storms and respiratory diseases in Washington State, 1991. *Archives of Environmental Health* 49:170-174.
- (33) Health Effects Institute. (1997) Particulate Air Pollution and Daily Mortality: Analyses of the Effects of Weather and Multiple Air Pollutants (The Phase I.B Report of the Particle Epidemiology Evaluation Project). Health Effects Institute, Cambridge, MA.
- (34) Health Effects Institute. (1995) Particulate Air Pollution and Daily Mortality: Replication and Validation of Selected Studies (The Phase I.A Report of the Particle Epidemiology Evaluation Project). Health Effects Institute, Cambridge, MA.
- (35) Hill, A.B. (1965) The environment and disease: associations or causation? Proceedings of the Royal Society of Medicine 58:295-300.
- (36) Ito, K.; Kinney, P.L.; Thurston, G.D. (1995) Variations in PM₁₀ concentrations within two metropolitan areas and their implications for health effects analyses. *Inhalation Toxicology* 7:735-745.

- (37) Katsouyanni, K.; Touloumi, G.; Spix, C.; Schwartz, J.; Balducci, F.; Medina, S.; Rossi, G.; Wojtyniak, B.; Sunyer, J.; Bacharova, L.; Schouten, J.P.; Ponka, A.; Anderson, H.R. (1997) Short-term effects of ambient sulphur dioxide and particulate matter on mortality in 12 European cities: results from the APHEA project. *British Medical Journal* (In press)
- (38) Killingsworth, C.R.; Alessandrini, F.; Krishna Murthy, G.G.; Catalano, P.J.; Paulauskis, J.D.; Godleski, J.J. (1997) Inflammation, chemokine expression, and death in monocrotaline-treated rats following fuel oil fly ash inhalation. *Inhalation Toxicology* (In press)
- (39) Koman, P.D. (1996) Memorandum to the files regarding PM_{2.5} Air Quality Values from PM Health Studies. September 30, 1996.
- (40) Koman, P.D. (1997) Supplemental Information Regarding PM_{2.5} Air Quality Values from Key Short-term Fine Particle Exposure Studies. June 30, 1997.
- (41) Li, Y.; Roth, H.D. (1995) Daily mortality analysis by using different regression models in Philadelphia County, 1973–1990. *Inhalation Toxicology* 7:45–58.
- (42) Lipfert, F.W.; Wyzga, R.E. (1997) Air pollution and mortality: the implications of uncertainties in regression modeling and exposure measurement. *Journal of Air & Waste Management* 47:517–523.
- (43) Lipfert, F.W.; Urch, R.B. (1997) Personal exposures of asthmatics to air pollution in Toronto and implications for epidemiological studies. Submitted as attachment to comments on the proposed National Ambient Air Quality Standard for particulate matter by R.E. Wyzga, Docket No. A-95-54, IV-D-2672. March 11, 1997.
- (44) Lipfert, F.W. (1995) Estimating air pollution-mortality risks from cross-sectional studies: prospective vs. ecologic study designs. In: Particulate matter: health and regulatory issues: proceedings of an international specialty conference; April; Pittsburgh, PA. Pittsburgh, PA: Air & Waste Management Association; p. 78–102. (Air & Waste Management Association Publication VIP-49)
- (45) Lipfert, F.W.; Wyzga, R.E. (1995) Air pollution and mortality: issues and uncertainties. *Journal of Air & Waste Management Association* 45:949–966.
- (46) Lippmann, M.; Shy, C.; Stolwijk, J.; Speizer, F. (1996) Letter to Administrator Carol M. Browner. Supplement to the Closure Letter from the Clean Air Scientific Advisory Committee. March 20, 1996.
- (47) Lippman, M. (1986) Letter from Morton Lippmann, Chair, Clean Air Act Scientific Advisory Committee, to Administrator Lee M. Thomas.
- (48) Lipsett, M.; Hurley, S.; Ostro, B. (1997) Air Pollution and emergency room visits for asthma in Santa Clara County, California. *Environmental Health Perspectives* 105(2):216–222
- (49) Lyon, J.L.; Mori, M.; Gao, R. (1995) Is there a causal association between excess mortality and exposure to PM₁₀ air pollution? Additional analyses by location, year, season and cause of death. *Inhalation Toxicology* 7:603–614.
- (50) Martin, A.E.; Bradley, W.H. (1960) Mortality, fog and atmospheric pollution: an investigation during the winter of 1958–1959. Monthly Bulletin of the Minister of Health, Public Health Laboratory Service (GB) 19:56–73.
- (51) Ministry of Health - London - Her Majesty's Stationary Office (1954) Reports on Public Health and Medical Subjects No. 95. Mortality and Morbidity During the London Fog of December 1952.
- (52) Moolgavkar, S.H.; Luebeck, E.G.; Anderson, E.L. (1997) Air pollution and hospital admissions for respiratory causes in Minneapolis-St. Paul and Birmingham. *Epidemiology* 8:364–370.
- (53) Moolgavkar, S.H.; Luebeck, E.G. (1996) Particulate air pollution and mortality: a critical review of the evidence. *Epidemiology* 7:420–428.
- (54) Moolgavkar, S.H.; Luebeck, E.G.; Hall, T.A.; Anderson, E.L. (1995a) Air pollution and daily mortality in Philadelphia. *Epidemiology* 6:476–484.
- (55) Moolgavkar, S.H.; Luebeck, E.G.; Hall, T.A.; Anderson, E.L. (1995b) Particulate air pollution, sulfur dioxide, and daily mortality: a reanalysis of the Steubenville data. *Inhalation Toxicology* 7:35–44.
- (56) Neas L.M.; Dockery D.W.; Koutrakis P.; Tollerud, D.J.; Speizer, F.E. (1995) The association of ambient air pollution with twice daily peak expiratory flow rate measurements in children. *American Journal of Epidemiology* 141:111–122.
- (57) National Mining Association. (1997) Comments of the National Mining Association on the proposed revisions to the national ambient air quality standards for particulate matter. Docket No. A-95-54, IV-D-2158. March 12, 1997.
- (58) Ozkaynak, H.; Spengler, J.D. (1996) The role of outdoor particulate matter in assessing total human exposure. In: Particles in Our Air: Concentrations and Health Effects. Harvard University Press. Wilson, R; Spengler, J.D.; eds.
- (59) Peters, A.; Wichmann, H-E.; Tuch, T.; Heinrich, J.; Heyder, J. (1997) Respiratory effects are associated with the number of ultrafine particles. *American Journal of Respiratory Critical Care Medicine* 155:(In press).
- (60) Pacific Gas and Electric Company (1997) Comments on the proposed PM_{2.5} fine particulate standard. Docket No. A-95-54, IV-D-2183. March 11, 1997.
- (61) Pope, C.A., III; Kalkstein, J.S. (1996) Synoptic weather modeling and estimates of the exposure-response relationship between daily mortality and particulate air pollution. *Environmental Health Perspectives* 104:414–420.
- (62) Pope, C.A., III; Thun, M.J.; Namboori, M.M.; Dockery, D.W.; Evans, J.S.; Speizer, F.E.; Heath, D.W., Jr. (1995) Particulate air pollution as a predictor of mortality in a prospective study of U.S. adults. *American Journal of Respiratory and Critical Care Medicine* 151:669–674.
- (63) Pope, C.A., III; Schwartz, J.; Ransom, M.R. (1992) Daily mortality and PM₁₀ pollution in Utah Valley. *Archives Environmental Health* 47:211–217.
- (64) Pope, C.A., III; Dockery, D.W. (1992) Acute health effects of PM₁₀ pollution on symptomatic and asymptomatic children. *American Review of Respiratory Disease* 145:1123–1128.
- (65) Raizenne, M.; Neas, L.M.; Damokosh, A.I.; Dockery, D.W.; Spengler, J.D.; Koutrakis, P.; Ware, J.H.; Speizer, F.E. (1996) Health effects of acid aerosols on North American children: pulmonary function. *Environmental Health Perspectives* 104:506–514.
- (66) Roth, H.D.; Li, Y. (1997) Analysis of the association between air pollutants with mortality and hospital admissions in Birmingham, Alabama: 1986–1990. (Submitted for publication)
- (67) Roth, H.D. et al. (1997) Analysis of the association between total particulate matter and daily mortality in the Czech Republic: 1986–1994. Submitted as an attachment to comments of R.E. Wyzga, Docket No. A-95-54, IV-D-2672. March 11, 1997.
- (68) Sacks, J.; Karr, A.F.; Smith, R.L.; Davis, J.M. (1997) Comment on Scientific Input to Decision-Making on Airborne Particulate Standards. Docket No. A-95-54, IV-D-14,298. March 12, 1997.
- (69) Samet, J.M.; Zeger, S.L.; Kelsall, J.E.; Xu, J. (1996a) Air pollution and mortality in Philadelphia 1973–1988: Report to the Health Effects Institute on Phase I.B of the Particle Epidemiology Evaluation Project. Health Effects Institute, Cambridge, MA.
- (70) Samet, J.M.; Zeger, S.L.; Kelsall, J.E.; Xu, J.; Kalkstein, L.S. (1996b) Weather, air pollution, and mortality in Philadelphia, 1973–1980: Report to the Health Effects Institute on Phase I.B of the Particle Epidemiology Evaluation Project. Health Effects Institute, Cambridge, MA.
- (71) Samet, J.M.; Zeger, S.L.; Berthane, K. (1995) The association of mortality and particulate air pollution. In: Particulate Air Pollution and Daily Mortality: Replication and Validation of Selected Studies (The Phase I.A Report of the Particle Epidemiology Evaluation Project) pp. 3–104. Health Effects Institute, Cambridge, MA.
- (72) Scarlett, J.F.; Abbott, K.J.; Peacock, J.L.; Strachan, D.P.; Anderson, H.R. (1996) Acute effects of summer air pollution on respiratory function in primary school children in southern England. *Thorax* 51:1109–1114.
- (73) Schulze, W.D.; Brookshire, D.S.; Walther, E.G.; MacFarland, K. K.; Thayer, M.A.; Whitworth, R.L.; Ben-David, S.; Malm, W.; Molenar, Jr. (1983) The economic benefits of preserving visibility in the national parklands of the southwest. *Natural Resources Journal* 23:149–173.
- (74) Schwartz, J.; Dockery, D.W.; Neas, L.M. (1996) Is daily mortality associated specifically with fine particles? *Journal of Air & Waste Management Association* 46:927–939.
- (75) Schwartz, J.; Dockery, D.W.; Neas, L.M.; Wypij, D.; Ware, J.H.; Spengler, J.D.; Koutrakis, P.; Speizer, F.E.; Ferris, Jr., B.G. (1994) Acute effects of summer air pollution on respiratory symptom reporting in children. *American Journal of Respiratory and Critical Care Medicine* 150:1234–1242.
- (76) Schwartz, J. (1994) Air pollution and hospital admissions for the elderly in Birmingham, Alabama. *American Journal of Epidemiology* 139:589–598.
- (77) Schwartz, J. (1993) Air pollution and daily mortality in Birmingham, Alabama. *American Journal of Epidemiology* 137:1136–1147.
- (78) Schwartz, J.; Dockery, D.W. (1992a) Increased mortality in Philadelphia associated with daily air pollution concentrations. *American Review of Respiratory Disease* 145:600–604.
- (79) Schwartz, J.; Dockery, D.W. (1992b) Particulate air pollution and daily mortality in Steubenville, Ohio. *American Journal of Epidemiology* 135:12–19
- (80) Siskler, J.; Malm, W.; Molenar, J.; Gebhardt, K. (1996) Spatial and Seasonal Patterns and Long Term Variability of the Chemical Composition of the Haze in the U.S.: An Analysis of Data from the IMPROVE Network. Fort Collins, CO: Cooperative Institute for Research in the Atmosphere, Colorado State University. July 1996.
- (81) Styer, P.; McMillan, N.; Gao, F.; Davis, J.; Sacks, J. (1995) Effect of outdoor airborne particulate matter on daily death counts. *Environmental Health Perspectives* 103:490–497.
- (82) Swiss EKL. (1996) Report No. 270. Swiss Federal Commission of Air Hygiene (EKL). Docket No. A-95-54, IV-I-59.

(83) Thurston, G.D. (1997) Letter to President William J. Clinton. Docket No. A-95-54, IV-F-97. January 10, 1997.

(84) Thurston, G.D.; Ito, K.; Hayes, C.G.; Bates, D.V.; Lippmann, M. (1994) Respiratory hospital admissions and summertime haze air pollution in Toronto, Ontario: consideration of the role of acid aerosols. *Environmental Research* 55:271-290.

(85) Utility Air Regulatory Group. (1997) Comments on the proposed air quality standards. Docket No. A-95-54, IV-D-2250. March 14, 1997

(86) United Kingdom Department of Environment. (1997) The United Kingdom National Air Quality Strategy. United Kingdom of the Environment. Scottish Office. Docket No. A-95-54, IV-I-58. March 1997.

(87) U.S. Department of Health, Education and Welfare (1964) Smoking and health: report of the Advisory Committee to the Surgeon General of the Public Health Service. Washington, DC: Public Health Service; p. 60.

(88) U.S. Environmental Protection Agency (1996a) Air Quality Criteria for Particulate Matter. Research Triangle Park, NC: National Center for Environmental Assessment. Office of Research and Development. April 12, 1996.

(89) U.S. Environmental Protection Agency (1996b) Review of the National Ambient Air Quality Standards for Particulate Matter: Policy Assessment of Scientific and Technical Information—Office of Air Quality Planning and Standards Staff Paper. Office of Air Quality Planning and Standards. Office of Air and Radiation. July 1996.

(90) U.S. Environmental Protection Agency (1996c) Transcript of the Clean Air Scientific Advisory Committee's Review of the Particulate Matter Staff Paper Meetings held on May 6-7, 1996 in Chapel Hill, NC.

(91) U.S. Environmental Protection Agency (1993) Office of Air Quality Planning and Standards Effects of the 1990 Clean Air Act Amendments on Visibility in Class I Areas: An EPA Report to Congress. Research Triangle Park, NC.

(92) Valdberg, P.A. (1997) Causality has not been demonstrated between outdoor levels of particulate matter (PM) and daily mortality and morbidity. In: Comments of the Engine Manufacturers Association on the proposed revisions to NAAQS for particulate matter and ozone. Docket No. A-95-54, IV-D-2328. March 11, 1997.

(93) Ware, J.H.; Ferris, B.G., Jr.; Dockery, D.W.; Spengler, J.D.; Stram, D.O.; Speizer, F.E. (1986) Effects of ambient sulfur oxides and suspended particles on respiratory health of children. *American Review of Respiratory Disease* 133:834-842.

(94) World Health Organization. (1997) Update and Revision of the WHO Air Quality Guidelines for Europe. European Centre for Environment and Health. (In press). Docket No. A-95-54, IV-I-60.

(95) Wolff, G.T. (1996a) Letter from George T. Wolff, Chair, Clean Air Scientific Advisory Committee, to Administrator Carol M. Browner. Closure letter on draft Air Quality Criteria for Particulate Matter. March 15, 1996.

(96) Wolff, G.T. (1996b) Letter from George T. Wolff, Chair, Clean Air Scientific Advisory Committee, to Administrator Carol M. Browner. Closure letter on draft OAQPS Staff Paper (Review of the National Ambient Air Quality Standards for Particulate Matter: policy Assessment of Scientific and Technical Information). June 13, 1996.

(97) Woodruff, T.J.; Grillo, J.; Schoendorf, K.C.; 1997. The relationship between selected causes of

postneonatal infant mortality and particulate air pollution in the United States. *Environmental Health Perspectives* 105:(In press)

(98) Wordley, J.; Walters, S.; Ayres, J.R. (1997) Short-term variations in hospital admissions and mortality and particulate air pollution. *Occupational and Environmental Medicine* 54:108-116.

(99) Wyzga, R.E.; Lipfert, F.W. (1995) Temperature-pollution interactions with daily mortality in Philadelphia. In: Particulate matter: health and regulatory issues: proceedings of an international specialty conference; April; Pittsburgh, PA. Air & Waste Management Association, Pittsburgh, PA (Air & Waste Management Association Publication VIP-49)

List of Subjects in 40 CFR Part 50

Environmental protection, Air pollution control, Carbon monoxide, Lead, Nitrogen dioxide, Ozone, Particulate matter, Sulfur oxides.

Dated: July 16, 1997.

Carol M. Browner,
Administrator.

Therefore, 40 CFR Chapter I is amended as follows:

PART 50—NATIONAL PRIMARY AND SECONDARY AMBIENT AIR QUALITY STANDARDS

1. The authority citation for part 50 continues to read as follows:

Authority: Secs. 109 and 301(a), Clean Air Act, as amended (42 U.S.C. 7409, 7601(a)).

2. Section 50.3 is revised to read as follows:

§ 50.3 Reference conditions.

All measurements of air quality that are expressed as mass per unit volume (e.g., micrograms per cubic meter) other than for the particulate matter (PM₁₀ and PM_{2.5}) standards contained in § 50.7 shall be corrected to a reference temperature of 25 °C and a reference pressure of 760 millimeters of mercury (1,013.2 millibars). Measurements of PM₁₀ and PM_{2.5} for purposes of comparison to the standards contained in § 50.7 shall be reported based on actual ambient air volume measured at the actual ambient temperature and pressure at the monitoring site during the measurement period.

3. Section 50.6 is amended by revising the section heading and adding paragraph (d) to read as follows:

§ 50.6 National primary and secondary ambient air quality standards for PM₁₀.

* * * * *

(d) The PM₁₀ standards set forth in this section will no longer apply to an area not attaining these standards as of September 16, 1997, once EPA takes final action to promulgate a rule pursuant to section 172(e) of the Clean Air Act, as amended (42 U.S.C. 7472(e)) applicable to the area. The PM₁₀ standards set forth in this section will no

longer apply to an area attaining these standards as of September 16, 1997, once EPA approves a State Implementation Plan (SIP) applicable to the area containing all PM₁₀ control measures adopted and implemented by the state prior to September 16, 1997, and a section 110 SIP implementing the PM standards published on July 18, 1997. SIP approvals are codified in 40 CFR part 52.

4. Section 50.7 is added to read as follows:

§ 50.7 National primary and secondary ambient air quality standards for particulate matter.

(a) The national primary and secondary ambient air quality standards for particulate matter are:

(1) 15.0 micrograms per cubic meter (µg/m³) annual arithmetic mean concentration, and 65 µg/m³ 24-hour average concentration measured in the ambient air as PM_{2.5} (particles with an aerodynamic diameter less than or equal to a nominal 2.5 micrometers) by either:

(i) A reference method based on Appendix L of this part and designated in accordance with part 53 of this chapter; or

(ii) An equivalent method designated in accordance with part 53 of this chapter.

(2) 50 micrograms per cubic meter (µg/m³) annual arithmetic mean concentration, and 150 µg/m³ 24-hour average concentration measured in the ambient air as PM₁₀ (particles with an aerodynamic diameter less than or equal to a nominal 10 micrometers) by either:

(i) A reference method based on Appendix M of this part and designated in accordance with part 53 of this chapter; or

(ii) An equivalent method designated in accordance with part 53 of this chapter.

(b) The annual primary and secondary PM_{2.5} standards are met when the annual arithmetic mean concentration, as determined in accordance with Appendix N of this part, is less than or equal to 15.0 micrograms per cubic meter.

(c) The 24-hour primary and secondary PM_{2.5} standards are met when the 98th percentile 24-hour concentration, as determined in accordance with Appendix N of this part, is less than or equal to 65 micrograms per cubic meter.

(d) The annual primary and secondary PM₁₀ standards are met when the annual arithmetic mean concentration, as determined in accordance with Appendix N of this part, is less than or equal to 50 micrograms per cubic meter.

(e) The 24-hour primary and secondary PM₁₀ standards are met when the 99th percentile 24-hour concentration, as determined in accordance with Appendix N of this part, is less than or equal to 150 micrograms per cubic meter.

5. Appendix K is revised (for conformity with the format of the other appendices in this part) to read as follows:

Appendix K to Part 50—Interpretation of the National Ambient Air Quality Standards for Particulate Matter

1.0 General.

(a) This appendix explains the computations necessary for analyzing particulate matter data to determine attainment of the 24-hour and annual standards specified in 40 CFR 50.6. For the primary and secondary standards, particulate matter is measured in the ambient air as PM₁₀ (particles with an aerodynamic diameter less than or equal to a nominal 10 micrometers) by a reference method based on appendix J of this part and designated in accordance with part 53 of this chapter, or by an equivalent method designated in accordance with part 53 of this chapter. The required frequency of measurements is specified in part 58 of this chapter.

(b) The terms used in this appendix are defined as follows:

Average refers to an arithmetic mean. All particulate matter standards are expressed in terms of expected annual values: Expected number of exceedances per year for the 24-hour standards and expected annual arithmetic mean for the annual standards.

Daily value for PM₁₀ refers to the 24-hour average concentration of PM₁₀ calculated or measured from midnight to midnight (local time).

Exceedance means a daily value that is above the level of the 24-hour standard after rounding to the nearest 10 µg/m³ (i.e., values ending in 5 or greater are to be rounded up).

Expected annual value is the number approached when the annual values from an increasing number of years are averaged, in the absence of long-term trends in emissions or meteorological conditions.

Year refers to a calendar year.

(c) Although the discussion in this appendix focuses on monitored data, the same principles apply to modeling data, subject to EPA modeling guidelines.

2.0 Attainment Determinations.

2.1 24-Hour Primary and Secondary Standards.

(a) Under 40 CFR 50.6(a) the 24-hour primary and secondary standards are attained when the expected number of exceedances per year at each monitoring site is less than or equal to one. In the simplest case, the number of expected exceedances at a site is determined by recording the number of exceedances in each calendar year and then averaging them over the past 3 calendar years. Situations in which 3 years of data are not available and possible adjustments for unusual events or trends are discussed in sections 2.3 and 2.4 of this appendix. Further, when data for a year are incomplete, it is necessary to compute an estimated number of exceedances for that year by adjusting the observed number of exceedances. This procedure, performed by calendar quarter, is described in section 3.0 of this appendix. The expected number of exceedances is then estimated by averaging the individual annual estimates for the past 3 years.

(b) The comparison with the allowable expected exceedance rate of one per year is made in terms of a number rounded to the nearest tenth (fractional values equal to or greater than 0.05 are to be rounded up; e.g., an exceedance rate of 1.05 would be rounded to 1.1, which is the lowest rate for nonattainment).

2.2 *Annual Primary and Secondary Standards.* Under 40 CFR 50.6(b), the annual primary and secondary standards are attained when the expected

annual arithmetic mean PM₁₀ concentration is less than or equal to the level of the standard. In the simplest case, the expected annual arithmetic mean is determined by averaging the annual arithmetic mean PM₁₀ concentrations for the past 3 calendar years. Because of the potential for incomplete data and the possible seasonality in PM₁₀ concentrations, the annual mean shall be calculated by averaging the four quarterly means of PM₁₀ concentrations within the calendar year. The equations for calculating the annual arithmetic mean are given in section 4.0 of this appendix. Situations in which 3 years of data are not available and possible adjustments for unusual events or trends are discussed in sections 2.3 and 2.4 of this appendix. The expected annual arithmetic mean is rounded to the nearest 1 µg/m³ before comparison with the annual standards (fractional values equal to or greater than 0.5 are to be rounded up).

2.3 Data Requirements.

(a) 40 CFR 58.13 specifies the required minimum frequency of sampling for PM₁₀. For the purposes of making comparisons with the particulate matter standards, all data produced by National Air Monitoring Stations (NAMS), State and Local Air Monitoring Stations (SLAMS) and other sites submitted to EPA in accordance with the Part 58 requirements must be used, and a minimum of 75 percent of the scheduled PM₁₀ samples per quarter are required.

(b) To demonstrate attainment of either the annual or 24-hour standards at a monitoring site, the monitor must provide sufficient data to perform the required calculations of sections 3.0 and 4.0 of this appendix. The amount of data required varies with the sampling frequency, data capture rate and the number of years of record. In all cases, 3 years of representative monitoring data that meet the 75 percent criterion of the previous paragraph should be utilized, if available, and would suffice. More than 3 years may be considered, if all additional representative years of data meeting the 75 percent criterion are utilized. Data not meeting these criteria may also suffice to show attainment; however, such exceptions will have to be approved by the appropriate Regional Administrator in accordance with EPA guidance.

(c) There are less stringent data requirements for showing that a monitor has failed an attainment test and thus has recorded a violation of the particulate matter standards. Although it is generally necessary to meet the minimum 75 percent data capture requirement per quarter to use the computational equations described in sections 3.0 and 4.0 of this appendix, this criterion does not apply when less data is sufficient to unambiguously establish nonattainment. The following examples illustrate how nonattainment can be demonstrated when a site fails to meet the completeness criteria. Nonattainment of the 24-hour primary standards can be established by the observed annual number of exceedances (e.g., four observed exceedances in a single year), or by the estimated number of exceedances derived from the observed number of exceedances and the required number of scheduled samples (e.g., two observed exceedances with every other day sampling). Nonattainment of the annual standards can be demonstrated on the basis of quarterly mean concentrations developed from observed data combined with one-half the minimum detectable concentration substituted for missing values. In both cases, expected annual values must exceed the levels allowed by the standards.

2.4 *Adjustment for Exceptional Events and Trends.*

(a) An exceptional event is an uncontrollable event caused by natural sources of particulate matter or an event that is not expected to recur at a given location. Inclusion of such a value in the computation of exceedances or averages could result in inappropriate estimates of their respective expected annual values. To reduce the effect of unusual events, more than 3 years of representative data may be used. Alternatively, other techniques, such as the use of statistical models or the use of historical data could be considered so that the event may be discounted or weighted according to the likelihood that it will recur. The use of such techniques is subject to the approval of the appropriate Regional Administrator in accordance with EPA guidance.

(b) In cases where long-term trends in emissions and air quality are evident, mathematical techniques should be applied to account for the trends to ensure that the expected annual values are not inappropriately biased by unrepresentative data. In the simplest case, if 3 years of data are available under stable emission conditions, this data should be used. In the event of a trend or shift in emission patterns, either the most recent representative year(s) could be used or statistical techniques or models could be used in conjunction with previous years of data to adjust for trends. The use of less than 3 years of data, and any adjustments are subject to the approval of the appropriate Regional Administrator in accordance with EPA guidance.

3.0 Computational Equations for the 24-hour Standards.

3.1 Estimating Exceedances for a Year.

(a) If PM₁₀ sampling is scheduled less frequently than every day, or if some scheduled samples are missed, a PM₁₀ value will not be available for each day of the year. To account for the possible effect of incomplete data, an adjustment must be made to the data collected at each monitoring location to estimate the number of exceedances in a calendar year. In this adjustment, the assumption is made that the fraction of missing values that would have exceeded the standard level is identical to the fraction of measured values above this level. This computation is to be made for all sites that are scheduled to monitor throughout the entire year and meet the minimum data requirements of section 2.3 of this appendix. Because of possible seasonal imbalance, this adjustment shall be applied on a quarterly basis. The estimate of the expected number of exceedances for the quarter is equal to the observed number of exceedances plus an increment associated with the missing data. The following equation must be used for these computations:

Equation 1

$$e_q = v_q + \left[\left(v_q / n_q \right) \times \left(N_q - n_q \right) \right] = v_q \times N_q / n_q$$

where:

e_q = the estimated number of exceedances for calendar quarter q;

v_q = the observed number of exceedances for calendar quarter q;

N_q = the number of days in calendar quarter q;

n_q = the number of days in calendar quarter q with PM₁₀ data; and

q = the index for calendar quarter, q = 1, 2, 3 or 4.

(b) The estimated number of exceedances for a calendar quarter must be rounded to the nearest hundredth (fractional values equal to or greater than 0.005 must be rounded up).

(c) The estimated number of exceedances for the year, e , is the sum of the estimates for each calendar quarter.

Equation 2

$$e = \sum_{q=1}^4 e_q$$

(d) The estimated number of exceedances for a single year must be rounded to one decimal place (fractional values equal to or greater than 0.05 are to be rounded up). The expected number of exceedances is then estimated by averaging the individual annual estimates for the most recent 3 or more representative years of data. The expected number of exceedances must be rounded to one decimal place (fractional values equal to or greater than 0.05 are to be rounded up).

(e) The adjustment for incomplete data will not be necessary for monitoring or modeling data which constitutes a complete record, i.e., 365 days per year.

(f) To reduce the potential for overestimating the number of expected exceedances, the correction for missing data will not be required for a calendar quarter in which the first observed exceedance has occurred if:

(1) There was only one exceedance in the calendar quarter;

(2) Everyday sampling is subsequently initiated and maintained for 4 calendar quarters in accordance with 40 CFR 58.13; and

(3) Data capture of 75 percent is achieved during the required period of everyday sampling. In addition, if the first exceedance is observed in a calendar quarter in which the monitor is already sampling every day, no adjustment for missing data will be made to the first exceedance if a 75 percent data capture rate was achieved in the quarter in which it was observed.

Example 1

a. During a particular calendar quarter, 39 out of a possible 92 samples were recorded, with one observed exceedance of the 24-hour standard. Using Equation 1, the estimated number of exceedances for the quarter is:

$$e_q = 1 \times 92 / 39 = 2.359 \text{ or } 2.36.$$

b. If the estimated exceedances for the other 3 calendar quarters in the year were 2.30, 0.0 and 0.0, then, using Equation 2, the estimated number of exceedances for the year is $2.36 + 2.30 + 0.0 + 0.0$ which equals 4.66 or 4.7. If no exceedances were observed for the 2 previous years, then the expected number of exceedances is estimated by: $(1/3) \times (4.7 + 0 + 0) = 1.57$ or 1.6. Since 1.6 exceeds the allowable number of expected exceedances, this monitoring site would fail the attainment test.

Example 2

In this example, everyday sampling was initiated following the first observed exceedance as required by 40 CFR 58.13. Accordingly, the first observed exceedance would not be adjusted for incomplete sampling. During the next three quarters, 1.2 exceedances were estimated. In this case, the estimated exceedances for the year would be $1.0 + 1.2 + 0.0 + 0.0$ which equals 2.2. If, as before, no exceedances were observed for the two previous years, then the estimated exceedances for the 3-year period would then be $(1/3) \times (2.2 + 0.0 + 0.0) = 0.7$, and the monitoring site would *not* fail the attainment test.

3.2 Adjustments for Non-Scheduled Sampling Days.

(a) If a systematic sampling schedule is used and sampling is performed on days in addition to the days specified by the systematic sampling schedule, e.g., during episodes of high pollution, then an adjustment must be made in the equation for the estimation of exceedances. Such an adjustment is needed to eliminate the bias in the estimate of the quarterly and annual number of exceedances that would occur if the chance of an exceedance is different for scheduled than for non-scheduled days, as would be the case with episode sampling.

(b) The required adjustment treats the systematic sampling schedule as a stratified sampling plan. If the period from one scheduled sample until the day preceding the next scheduled sample is defined as a sampling stratum, then there is one stratum for each scheduled sampling day. An average number of observed exceedances is computed for each of these sampling strata. With nonscheduled sampling days, the estimated number of exceedances is defined as:

Equation 3

$$e_q = \left(N_q / m_q \right) \times \sum_{j=1}^{m_q} \left(v_j / k_j \right)$$

where:

e_q = the estimated number of exceedances for the quarter;

N_q = the number of days in the quarter;

m_q = the number of strata with samples during the quarter;

v_j = the number of observed exceedances in stratum j ; and

k_j = the number of actual samples in stratum j .

(c) Note that if only one sample value is recorded in each stratum, then Equation 3 reduces to Equation 1.

Example 3

A monitoring site samples according to a systematic sampling schedule of one sample every 6 days, for a total of 15 scheduled samples in a quarter out of a total of 92 possible samples. During one 6-day period, potential episode levels of PM_{10} were suspected, so 5 additional samples were taken. One of the regular scheduled samples was missed, so a total of 19 samples in 14 sampling strata were measured. The one 6-day sampling stratum with 6 samples recorded 2 exceedances. The remainder of the quarter with one sample per stratum recorded zero exceedances. Using Equation 3, the estimated number of exceedances for the quarter is:

$$e_q = (92/14) \times (2/6 + 0 + \dots + 0) = 2.19.$$

4.0 Computational Equations for Annual Standards.

4.1 Calculation of the Annual Arithmetic Mean.

(a) An annual arithmetic mean value for PM_{10} is determined by averaging the quarterly means for the 4 calendar quarters of the year. The following equation is to be used for calculation of the mean for a calendar quarter:

Equation 4

$$\bar{x}_q = \left(1/n_q \right) \times \sum_{i=1}^{n_q} x_i$$

where:

\bar{x}_q = the quarterly mean concentration for quarter q , $q=1, 2, 3, \text{ or } 4$,

n_q = the number of samples in the quarter, and x_i = the i th concentration value recorded in the quarter.

(b) The quarterly mean, expressed in $\mu\text{g}/\text{m}^3$, must be rounded to the nearest tenth (fractional values of 0.05 should be rounded up).

(c) The annual mean is calculated by using the following equation:

Equation 5

$$\bar{x} = \left(1/4 \right) \times \sum_{q=1}^4 \bar{x}_q$$

where:

\bar{x} = the annual mean; and

\bar{x}_q = the mean for calendar quarter q .

(d) The average of quarterly means must be rounded to the nearest tenth (fractional values of 0.05 should be rounded up).

(e) The use of quarterly averages to compute the annual average will not be necessary for monitoring or modeling data which results in a complete record, i.e., 365 days per year.

(f) The expected annual mean is estimated as the average of three or more annual means. This multi-year estimate, expressed in $\mu\text{g}/\text{m}^3$, shall be rounded to the nearest integer for comparison with the annual standard (fractional values of 0.5 should be rounded up).

Example 4

Using Equation 4, the quarterly means are calculated for each calendar quarter. If the quarterly means are 52.4, 75.3, 82.1, and 63.2 $\mu\text{g}/\text{m}^3$, then the annual mean is:

$$\bar{x} = (1/4) \times (52.4 + 75.3 + 82.1 + 63.2) = 68.25 \text{ or } 68.3.$$

4.2 Adjustments for Non-scheduled Sampling Days.

(a) An adjustment in the calculation of the annual mean is needed if sampling is performed on days in addition to the days specified by the systematic sampling schedule. For the same reasons given in the discussion of estimated exceedances, under section 3.2 of this appendix, the quarterly averages would be calculated by using the following equation:

Equation 6

$$\bar{x}_q = \left(1/m_q \right) \times \sum_{j=1}^{m_q} \sum_{i=1}^{k_j} \left(x_{ij} / k_j \right)$$

where:

\bar{x}_q = the quarterly mean concentration for quarter q , $q=1, 2, 3, \text{ or } 4$;

x_{ij} = the i th concentration value recorded in stratum j ;

k_j = the number of actual samples in stratum j ; and

m_q = the number of strata with data in the quarter.

(b) If one sample value is recorded in each stratum, Equation 6 reduces to a simple arithmetic average of the observed values as described by Equation 4.

Example 5

a. During one calendar quarter, 9 observations were recorded. These samples were distributed among 7 sampling strata, with 3 observations in one stratum. The concentrations of the 3 observations in the single stratum were 202, 242, and 180 $\mu\text{g}/\text{m}^3$. The remaining 6 observed

concentrations were 55, 68, 73, 92, 120, and 155 $\mu\text{g}/\text{m}^3$. Applying the weighting factors specified in Equation 6, the quarterly mean is:

$$\bar{x}_q = (1/7) \times [(1/3) \times (202 + 242 + 180) + 155 + 68 + 73 + 92 + 120 + 155] = 110.1$$

b. Although 24-hour measurements are rounded to the nearest 10 $\mu\text{g}/\text{m}^3$ for determinations of exceedances of the 24-hour standard, note that these values are rounded to the nearest 1 $\mu\text{g}/\text{m}^3$ for the calculation of means.

6. Appendix L is added to read as follows:

Appendix L to Part 50—Reference Method For the Determination of Fine Particulate Matter as $\text{PM}_{2.5}$ in the Atmosphere

1.0 Applicability.

1.1 This method provides for the measurement of the mass concentration of fine particulate matter having an aerodynamic diameter less than or equal to a nominal 2.5 micrometers ($\text{PM}_{2.5}$) in ambient air over a 24-hour period for purposes of determining whether the primary and secondary national ambient air quality standards for fine particulate matter specified in § 50.6 of this part are met. The measurement process is considered to be nondestructive, and the $\text{PM}_{2.5}$ sample obtained can be subjected to subsequent physical or chemical analyses. Quality assessment procedures are provided in part 58, Appendix A of this chapter, and quality assurance guidance are provided in references 1, 2, and 3 in section 13.0 of this appendix.

1.2 This method will be considered a reference method for purposes of part 58 of this chapter only if:

(a) The associated sampler meets the requirements specified in this appendix and the applicable requirements in part 53 of this chapter, and

(b) The method and associated sampler have been designated as a reference method in accordance with part 53 of this chapter.

1.3 $\text{PM}_{2.5}$ samplers that meet nearly all specifications set forth in this method but have minor deviations and/or modifications of the reference method sampler will be designated as "Class I" equivalent methods for $\text{PM}_{2.5}$ in accordance with part 53 of this chapter.

2.0 Principle.

2.1 An electrically powered air sampler draws ambient air at a constant volumetric flow rate into a specially shaped inlet and through an inertial particle size separator (impactor) where the suspended particulate matter in the $\text{PM}_{2.5}$ size range is separated for collection on a polytetrafluoroethylene (PTFE) filter over the specified sampling period. The air sampler and other aspects of this reference method are specified either explicitly in this appendix or generally with reference to other applicable regulations or quality assurance guidance.

2.2 Each filter is weighed (after moisture and temperature conditioning) before and after sample collection to determine the net gain due to collected $\text{PM}_{2.5}$. The total volume of air sampled is determined by the sampler from the measured flow rate at actual ambient temperature and pressure and the sampling time. The mass concentration of $\text{PM}_{2.5}$ in the ambient air is computed as the total mass of collected particles in the $\text{PM}_{2.5}$ size range divided by the actual volume of air sampled, and is expressed in micrograms per cubic meter of air ($\mu\text{g}/\text{m}^3$).

3.0 $\text{PM}_{2.5}$ Measurement Range.

3.1 *Lower concentration limit.* The lower detection limit of the mass concentration

measurement range is estimated to be approximately 2 $\mu\text{g}/\text{m}^3$, based on noted mass changes in field blanks in conjunction with the 24 m^3 nominal total air sample volume specified for the 24-hour sample.

3.2 *Upper concentration limit.* The upper limit of the mass concentration range is determined by the filter mass loading beyond which the sampler can no longer maintain the operating flow rate within specified limits due to increased pressure drop across the loaded filter. This upper limit cannot be specified precisely because it is a complex function of the ambient particle size distribution and type, humidity, the individual filter used, the capacity of the sampler flow rate control system, and perhaps other factors. Nevertheless, all samplers are estimated to be capable of measuring 24-hour $\text{PM}_{2.5}$ mass concentrations of at least 200 $\mu\text{g}/\text{m}^3$ while maintaining the operating flow rate within the specified limits.

3.3 *Sample period.* The required sample period for $\text{PM}_{2.5}$ concentration measurements by this method shall be 1,380 to 1500 minutes (23 to 25 hours). However, when a sample period is less than 1,380 minutes, the measured concentration (as determined by the collected $\text{PM}_{2.5}$ mass divided by the actual number of minutes in the sample period and divided by 1,440, may be used as if it were a valid concentration measurement for the specific purpose of determining a violation of the NAAQS. This value assumes that the $\text{PM}_{2.5}$ concentration is zero for the remaining portion of the sample period and therefore represents the minimum concentration that could have been measured for the full 24-hour sample period. Accordingly, if the value thus calculated is high enough to be an exceedance, such an exceedance would be a valid exceedance for the sample period. When reported to AIRS, this data value should receive a special code to identify it as not to be commingled with normal concentration measurements or used for other purposes.

4.0 Accuracy.

4.1 Because the size and volatility of the particles making up ambient particulate matter vary over a wide range and the mass concentration of particles varies with particle size, it is difficult to define the accuracy of $\text{PM}_{2.5}$ measurements in an absolute sense. The accuracy of $\text{PM}_{2.5}$ measurements is therefore defined in a relative sense, referenced to measurements provided by this reference method. Accordingly, accuracy shall be defined as the degree of agreement between a subject field $\text{PM}_{2.5}$ sampler and a collocated $\text{PM}_{2.5}$ reference method audit sampler operating simultaneously at the monitoring site location of the subject sampler and includes both random (precision) and systematic (bias) errors. The requirements for this field sampler audit procedure are set forth in part 58, Appendix A of this chapter.

4.2 Measurement system bias. Results of collocated measurements where the duplicate sampler is a reference method sampler are used to assess a portion of the measurement system bias according to the schedule and procedure specified in part 58, Appendix A of this chapter.

4.3 Audits with reference method samplers to determine system accuracy and bias. According to the schedule and procedure specified in part 58, Appendix A of this chapter, a reference method sampler is required to be located at each of selected $\text{PM}_{2.5}$ SLAMS sites as a duplicate sampler. The results from the primary sampler and the duplicate reference method sampler are used to calculate accuracy of the primary sampler on a quarterly basis, bias of the primary sampler on an annual

basis, and bias of a single reporting organization on an annual basis. Reference 2 in section 13.0 of this appendix provides additional information and guidance on these reference method audits.

4.4 Flow rate accuracy and bias. Part 58, Appendix A of this chapter requires that the flow rate accuracy and bias of individual $\text{PM}_{2.5}$ samplers used in SLAMS monitoring networks be assessed periodically via audits of each sampler's operational flow rate. In addition, part 58, Appendix A of this chapter requires that flow rate bias for each reference and equivalent method operated by each reporting organization be assessed quarterly and annually. Reference 2 in section 13.0 of this appendix provides additional information and guidance on flow rate accuracy audits and calculations for accuracy and bias.

5.0 *Precision.* A data quality objective of 10 percent coefficient of variation or better has been established for the operational precision of $\text{PM}_{2.5}$ monitoring data.

5.1 Tests to establish initial operational precision for each reference method sampler are specified as a part of the requirements for designation as a reference method under § 53.58 of this chapter.

5.2 Measurement System Precision. Collocated sampler results, where the duplicate sampler is not a reference method sampler but is a sampler of the same designated method as the primary sampler, are used to assess measurement system precision according to the schedule and procedure specified in part 58, Appendix A of this chapter. Part 58, Appendix A of this chapter requires that these collocated sampler measurements be used to calculate quarterly and annual precision estimates for each primary sampler and for each designated method employed by each reporting organization. Reference 2 in section 13.0 of this appendix provides additional information and guidance on this requirement.

6.0 *Filter for $\text{PM}_{2.5}$ Sample Collection.* Any filter manufacturer or vendor who sells or offers to sell filters specifically identified for use with this $\text{PM}_{2.5}$ reference method shall certify that the required number of filters from each lot of filters offered for sale as such have been tested as specified in this section 6.0 and meet all of the following design and performance specifications.

6.1 *Size.* Circular, 46.2 mm diameter ± 0.25 mm.

6.2 *Medium.* Polytetrafluoroethylene (PTFE Teflon), with integral support ring.

6.3 *Support ring.* Polymethylpentene (PMP) or equivalent inert material, 0.38 ± 0.04 mm thick, outer diameter 46.2 mm ± 0.25 mm, and width of 3.68 mm (± 0.00 , -0.51 mm).

6.4 *Pore size.* 2 μm as measured by ASTM F 316-94.

6.5 *Filter thickness.* 30 to 50 μm .

6.6 *Maximum pressure drop (clean filter).* 30 cm H_2O column @ 16.67 L/min clean air flow.

6.7 *Maximum moisture pickup.* Not more than 10 μg weight increase after 24-hour exposure to air of 40 percent relative humidity, relative to weight after 24-hour exposure to air of 35 percent relative humidity.

6.8 *Collection efficiency.* Greater than 99.7 percent, as measured by the DOP test (ASTM D 2986-91) with 0.3 μm particles at the sampler's operating face velocity.

6.9 *Filter weight stability.* Filter weight loss shall be less than 20 μg , as measured in each of the following two tests specified in sections 6.9.1 and 6.9.2 of this appendix. The following conditions apply to both of these tests: Filter weight loss shall be the average difference between the initial and the final filter weights of a random sample of test

filters selected from each lot prior to sale. The number of filters tested shall be not less than 0.1 percent of the filters of each manufacturing lot, or 10 filters, whichever is greater. The filters shall be weighed under laboratory conditions and shall have had no air sample passed through them, i.e., filter blanks. Each test procedure must include initial conditioning and weighing, the test, and final conditioning and weighing. Conditioning and weighing shall be in accordance with sections 8.0 through 8.2 of this appendix and general guidance provided in reference 2 of section 13.0 of this appendix.

6.9.1 *Test for loose, surface particle contamination.* After the initial weighing, install each test filter, in turn, in a filter cassette (Figures L-27, L-28, and L-29 of this appendix) and drop the cassette from a height of 25 cm to a flat hard surface, such as a particle-free wood bench. Repeat two times, for a total of three drop tests for each test filter. Remove the test filter from the cassette and weigh the filter. The average change in weight must be less than 20 µg.

6.9.2 *Test for temperature stability.* After weighing each filter, place the test filters in a drying oven set at 40 °C ± 2 °C for not less than 48 hours. Remove, condition, and reweigh each test filter. The average change in weight must be less than 20 µg.

6.10 *Alkalinity.* Less than 25 microequivalents/gram of filter, as measured by the guidance given in reference 2 in section 13.0 of this appendix.

6.11 *Supplemental requirements.* Although not required for determination of PM_{2.5} mass concentration under this reference method, additional specifications for the filter must be developed by users who intend to subject PM_{2.5} filter samples to subsequent chemical analysis. These supplemental specifications include background chemical contamination of the filter and any other filter parameters that may be required by the method of chemical analysis. All such supplemental filter specifications must be compatible with and secondary to the primary filter specifications given in this section 6.0 of this appendix.

7.0 PM_{2.5} Sampler.

7.1 *Configuration.* The sampler shall consist of a sample air inlet, downtube, particle size separator (impactor), filter holder assembly, air pump and flow rate control system, flow rate measurement device, ambient and filter temperature monitoring system, barometric pressure measurement system, timer, outdoor environmental enclosure, and suitable mechanical, electrical, or electronic control capability to meet or exceed the design and functional performance as specified in this section 7.0 of this appendix. The performance specifications require that the sampler:

- (a) Provide automatic control of sample volumetric flow rate and other operational parameters.
- (b) Monitor these operational parameters as well as ambient temperature and pressure.
- (c) Provide this information to the sampler operator at the end of each sample period in digital form, as specified in Table L-1 of section 7.4.19 of this appendix.

7.2 *Nature of specifications.* The PM_{2.5} sampler is specified by a combination of design and performance requirements. The sample inlet, downtube, particle size discriminator, filter cassette, and the internal configuration of the filter holder assembly are specified explicitly by design figures and associated mechanical dimensions, tolerances, materials, surface finishes, assembly

instructions, and other necessary specifications. All other aspects of the sampler are specified by required operational function and performance, and the design of these other aspects (including the design of the lower portion of the filter holder assembly) is optional, subject to acceptable operational performance. Test procedures to demonstrate compliance with both the design and performance requirements are set forth in subpart E of part 53 of this chapter.

7.3 *Design specifications.* Except as indicated in this section 7.3 of this appendix, these components must be manufactured or reproduced exactly as specified, in an ISO 9001-registered facility, with registration initially approved and subsequently maintained during the period of manufacture. See § 53.1(t) of this chapter for the definition of an ISO-registered facility. Minor modifications or variances to one or more components that clearly would not affect the aerodynamic performance of the inlet, downtube, impactor, or filter cassette will be considered for specific approval. Any such proposed modifications shall be described and submitted to the EPA for specific individual acceptability either as part of a reference or equivalent method application under part 53 of this chapter or in writing in advance of such an intended application under part 53 of this chapter.

7.3.1 *Sample inlet assembly.* The sample inlet assembly, consisting of the inlet, downtube, and impactor shall be configured and assembled as indicated in Figure L-1 of this appendix and shall meet all associated requirements. A portion of this assembly shall also be subject to the maximum overall sampler leak rate specification under section 7.4.6 of this appendix.

7.3.2 *Inlet.* The sample inlet shall be fabricated as indicated in Figures L-2 through L-18 of this appendix and shall meet all associated requirements.

7.3.3 *Downtube.* The downtube shall be fabricated as indicated in Figure L-19 of this appendix and shall meet all associated requirements.

7.3.4 *Impactor.*

7.3.4.1 The impactor (particle size separator) shall be fabricated as indicated in Figures L-20 through L-24 of this appendix and shall meet all associated requirements. Following the manufacture and finishing of each upper impactor housing (Figure L-21 of this appendix), the dimension of the impaction jet must be verified by the manufacturer using Class ZZ go/no-go plug gauges that are traceable to NIST.

7.3.4.2 *Impactor filter specifications:*

- (a) Size. Circular, 35 to 37 mm diameter.
- (b) Medium. Borosilicate glass fiber, without binder.
- (c) Pore size. 1 to 1.5 micrometer, as measured by ASTM F 316-80.
- (d) Thickness. 300 to 500 micrometers.

7.3.4.3 *Impactor oil specifications:*

- (a) Composition. Tetramethyltetraphenyltrisiloxane, single-compound diffusion oil.
- (b) Vapor pressure. Maximum 2 x 10⁻⁸ mm Hg at 25 °C.
- (c) Viscosity. 36 to 40 centistokes at 25 °C.
- (d) Density. 1.06 to 1.07 g/cm³ at 25 °C.
- (e) Quantity. 1 mL ± 0.1 mL.

7.3.5 *Filter holder assembly.* The sampler shall have a sample filter holder assembly to adapt and seal to the down tube and to hold and seal the specified filter, under section 6.0 of this appendix, in the sample air stream in a horizontal position below the downtube such that the sample air passes

downward through the filter at a uniform face velocity. The upper portion of this assembly shall be fabricated as indicated in Figures L-25 and L-26 of this appendix and shall accept and seal with the filter cassette, which shall be fabricated as indicated in Figures L-27 through L-29 of this appendix.

(a) The lower portion of the filter holder assembly shall be of a design and construction that:

- (1) Mates with the upper portion of the assembly to complete the filter holder assembly,
- (2) Completes both the external air seal and the internal filter cassette seal such that all seals are reliable over repeated filter changings, and
- (3) Facilitates repeated changing of the filter cassette by the sampler operator.

(b) Leak-test performance requirements for the filter holder assembly are included in section 7.4.6 of this appendix.

(c) If additional or multiple filters are stored in the sampler as part of an automatic sequential sample capability, all such filters, unless they are currently and directly installed in a sampling channel or sampling configuration (either active or inactive), shall be covered or (preferably) sealed in such a way as to:

- (1) Preclude significant exposure of the filter to possible contamination or accumulation of dust, insects, or other material that may be present in the ambient air, sampler, or sampler ventilation air during storage periods either before or after sampling; and
- (2) To minimize loss of volatile or semi-volatile PM sample components during storage of the filter following the sample period.

7.3.6 *Flow rate measurement adapter.* A flow rate measurement adapter as specified in Figure L-30 of this appendix shall be furnished with each sampler.

7.3.7 *Surface finish.* All internal surfaces exposed to sample air prior to the filter shall be treated electrolytically in a sulfuric acid bath to produce a clear, uniform anodized surface finish of not less than 1000 mg/ft² (1.08 mg/cm²) in accordance with military standard specification (mil. spec.) 8625F, Type II, Class 1 in reference 4 of section 13.0 of this appendix. This anodic surface coating shall not be dyed or pigmented. Following anodization, the surfaces shall be sealed by immersion in boiling deionized water for not less than 15 minutes. Section 53.51(d)(2) of this chapter should also be consulted.

7.3.8 *Sampling height.* The sampler shall be equipped with legs, a stand, or other means to maintain the sampler in a stable, upright position and such that the center of the sample air entrance to the inlet, during sample collection, is maintained in a horizontal plane and is 2.0 ± 0.2 meters above the floor or other horizontal supporting surface. Suitable bolt holes, brackets, tie-downs, or other means should be provided to facilitate mechanically securing the sample to the supporting surface to prevent toppling of the sampler due to wind.

7.4 *Performance specifications.*

7.4.1 *Sample flow rate.* Proper operation of the impactor requires that specific air velocities be maintained through the device. Therefore, the design sample air flow rate through the inlet shall be 16.67 L/min (1.000 m³/hour) measured as actual volumetric flow rate at the temperature and pressure of the sample air entering the inlet.

7.4.2 *Sample air flow rate control system.* The sampler shall have a sample air flow rate control system which shall be capable of providing a sample air volumetric flow rate within the specified range, under section 7.4.1 of this appendix, for the

specified filter, under section 6.0 of this appendix, at any atmospheric conditions specified, under section 7.4.7 of this appendix, at a filter pressure drop equal to that of a clean filter plus up to 75 cm water column (55 mm Hg), and over the specified range of supply line voltage, under section 7.4.15.1 of this appendix. This flow control system shall allow for operator adjustment of the operational flow rate of the sampler over a range of at least ± 15 percent of the flow rate specified in section 7.4.1 of this appendix.

7.4.3 *Sample flow rate regulation.* The sample flow rate shall be regulated such that for the specified filter, under section 6.0 of this appendix, at any atmospheric conditions specified, under section 7.4.7 of this appendix, at a filter pressure drop equal to that of a clean filter plus up to 75 cm water column (55 mm Hg), and over the specified range of supply line voltage, under section 7.4.15.1 of this appendix, the flow rate is regulated as follows:

7.4.3.1 The volumetric flow rate, measured or averaged over intervals of not more than 5 minutes over a 24-hour period, shall not vary more than ± 5 percent from the specified 16.67 L/min flow rate over the entire sample period.

7.4.3.2 The coefficient of variation (sample standard deviation divided by the mean) of the flow rate, measured over a 24-hour period, shall not be greater than 2 percent.

7.4.3.3 The amplitude of short-term flow rate pulsations, such as may originate from some types of vacuum pumps, shall be attenuated such that they do not cause significant flow measurement error or affect the collection of particles on the particle collection filter.

7.4.4 *Flow rate cut off.* The sampler's sample air flow rate control system shall terminate sample collection and stop all sample flow for the remainder of the sample period in the event that the sample flow rate deviates by more than 10 percent from the sampler design flow rate specified in section 7.4.1 of this appendix for more than 60 seconds. However, this sampler cut-off provision shall not apply during periods when the sampler is inoperative due to a temporary power interruption, and the elapsed time of the inoperative period shall not be included in the total sample time measured and reported by the sampler, under section 7.4.13 of this appendix.

7.4.5 *Flow rate measurement.*

7.4.5.1 The sampler shall provide a means to measure and indicate the instantaneous sample air flow rate, which shall be measured as volumetric flow rate at the temperature and pressure of the sample air entering the inlet, with an accuracy of ± 2 percent. The measured flow rate shall be available for display to the sampler operator at any time in either sampling or standby modes, and the measurement shall be updated at least every 30 seconds. The sampler shall also provide a simple means by which the sampler operator can manually start the sample flow temporarily during non-sampling modes of operation, for the purpose of checking the sample flow rate or the flow rate measurement system.

7.4.5.2 During each sample period, the sampler's flow rate measurement system shall automatically monitor the sample volumetric flow rate, obtaining flow rate measurements at intervals of not greater than 30 seconds.

(a) Using these interval flow rate measurements, the sampler shall determine or calculate the following flow-related parameters, scaled in the specified engineering units:

(1) The instantaneous or interval-average flow rate, in L/min.

(2) The value of the average sample flow rate for the sample period, in L/min.

(3) The value of the coefficient of variation (sample standard deviation divided by the average) of the sample flow rate for the sample period, in percent.

(4) The occurrence of any time interval during the sample period in which the measured sample flow rate exceeds a range of ± 5 percent of the average flow rate for the sample period for more than 5 minutes, in which case a warning flag indicator shall be set.

(5) The value of the integrated total sample volume for the sample period, in m^3 .

(b) Determination or calculation of these values shall properly exclude periods when the sampler is inoperative due to temporary interruption of electrical power, under section 7.4.13 of this appendix, or flow rate cut off, under section 7.4.4 of this appendix.

(c) These parameters shall be accessible to the sampler operator as specified in Table L-1 of section 7.4.19 of this appendix. In addition, it is strongly encouraged that the flow rate for each 5-minute interval during the sample period be available to the operator following the end of the sample period.

7.4.6 *Leak test capability.*

7.4.6.1 *External leakage.* The sampler shall include an external air leak-test capability consisting of components, accessory hardware, operator interface controls, a written procedure in the associated Operation/Instruction Manual, under section 7.4.18 of this appendix, and all other necessary functional capability to permit and facilitate the sampler operator to conveniently carry out a leak test of the sampler at a field monitoring site without additional equipment. The sampler components to be subjected to this leak test include all components and their interconnections in which external air leakage would or could cause an error in the sampler's measurement of the total volume of sample air that passes through the sample filter.

(a) The suggested technique for the operator to use for this leak test is as follows:

(1) Remove the sampler inlet and installs the flow rate measurement adapter supplied with the sampler, under section 7.3.6 of this appendix.

(2) Close the valve on the flow rate measurement adapter and use the sampler air pump to draw a partial vacuum in the sampler, including (at least) the impactor, filter holder assembly (filter in place), flow measurement device, and interconnections between these devices, of at least 55 mm Hg (75 cm water column), measured at a location downstream of the filter holder assembly.

(3) Plug the flow system downstream of these components to isolate the components under vacuum from the pump, such as with a built-in valve.

(4) Stop the pump.

(5) Measure the trapped vacuum in the sampler with a built-in pressure measuring device.

(6) (i) Measure the vacuum in the sampler with the built-in pressure measuring device again at a later time at least 10 minutes after the first pressure measurement.

(ii) **Caution:** Following completion of the test, the adaptor valve should be opened slowly to limit the flow rate of air into the sampler. Excessive air flow rate may blow oil out of the impactor.

(7) Upon completion of the test, open the adaptor valve, remove the adaptor and plugs, and restore the sampler to the normal operating configuration.

(b) The associated leak test procedure shall require that for successful passage of this test, the

difference between the two pressure measurements shall not be greater than the number of mm of Hg specified for the sampler by the manufacturer, based on the actual internal volume of the sampler, that indicates a leak of less than 80 mL/min.

(c) Variations of the suggested technique or an alternative external leak test technique may be required for samplers whose design or configuration would make the suggested technique impossible or impractical. The specific proposed external leak test procedure, or particularly an alternative leak test technique, proposed for a particular candidate sampler may be described and submitted to the EPA for specific individual acceptability either as part of a reference or equivalent method application under part 53 of this chapter or in writing in advance of such an intended application under part 53 of this chapter.

7.4.6.2 *Internal, filter bypass leakage.* The sampler shall include an internal, filter bypass leak-check capability consisting of components, accessory hardware, operator interface controls, a written procedure in the Operation/Instruction Manual, and all other necessary functional capability to permit and facilitate the sampler operator to conveniently carry out a test for internal filter bypass leakage in the sampler at a field monitoring site without additional equipment. The purpose of the test is to determine that any portion of the sample flow rate that leaks past the sample filter without passing through the filter is insignificant relative to the design flow rate for the sampler.

(a) The suggested technique for the operator to use for this leak test is as follows:

(1) Carry out an external leak test as provided under section 7.4.6.1 of this appendix which indicates successful passage of the prescribed external leak test.

(2) Install a flow-impervious membrane material in the filter cassette, either with or without a filter, as appropriate, which effectively prevents air flow through the filter.

(3) Use the sampler air pump to draw a partial vacuum in the sampler, downstream of the filter holder assembly, of at least 55 mm Hg (75 cm water column).

(4) Plug the flow system downstream of the filter holder to isolate the components under vacuum from the pump, such as with a built-in valve.

(5) Stop the pump.

(6) Measure the trapped vacuum in the sampler with a built-in pressure measuring device.

(7) Measure the vacuum in the sampler with the built-in pressure measuring device again at a later time at least 10 minutes after the first pressure measurement.

(8) Remove the flow plug and membrane and restore the sampler to the normal operating configuration.

(b) The associated leak test procedure shall require that for successful passage of this test, the difference between the two pressure measurements shall not be greater than the number of mm of Hg specified for the sampler by the manufacturer, based on the actual internal volume of the portion of the sampler under vacuum, that indicates a leak of less than 80 mL/min.

(c) Variations of the suggested technique or an alternative internal, filter bypass leak test technique may be required for samplers whose design or configuration would make the suggested technique impossible or impractical. The specific proposed internal leak test procedure, or particularly an alternative internal leak test technique proposed for a particular candidate sampler may be described

and submitted to the EPA for specific individual acceptability either as part of a reference or equivalent method application under part 53 of this chapter or in writing in advance of such intended application under part 53 of this chapter.

7.3.5 Filter holder assembly. The sampler shall have a sample filter holder assembly to adapt and seal to the down tube and to hold and seal the specified filter, under section 6.0 of this appendix, in the sample air stream in a horizontal position below the downtube such that the sample air passes downward through the filter at a uniform face velocity. The upper portion of this assembly shall be fabricated as indicated in Figures L-25 and L-26 of this appendix and shall accept and seal with the filter cassette, which shall be fabricated as indicated in Figures L-27 through L-29 of this appendix.

(a) The lower portion of the filter holder assembly shall be of a design and construction that:

(1) Mates with the upper portion of the assembly to complete the filter holder assembly,

(2) Completes both the external air seal and the internal filter cassette seal such that all seals are reliable over repeated filter changings, and

(3) Facilitates repeated changing of the filter cassette by the sampler operator.

(b) Leak-test performance requirements for the filter holder assembly are included in section 7.4.6 of this appendix.

(c) If additional or multiple filters are stored in the sampler as part of an automatic sequential sample capability, all such filters, unless they are currently and directly installed in a sampling channel or sampling configuration (either active or inactive), shall be covered or (preferably) sealed in such a way as to:

(1) Preclude significant exposure of the filter to possible contamination or accumulation of dust, insects, or other material that may be present in the ambient air, sampler, or sampler ventilation air during storage periods either before or after sampling; and

(2) To minimize loss of volatile or semi-volatile PM sample components during storage of the filter following the sample period.

7.3.6 Flow rate measurement adapter. A flow rate measurement adapter as specified in Figure L-30 of this appendix shall be furnished with each sampler.

7.3.7 Surface finish. All internal surfaces exposed to sample air prior to the filter shall be treated electrolytically in a sulfuric acid bath to produce a clear, uniform anodized surface finish of not less than 1000 mg/ft² (1.08 mg/cm²) in accordance with military standard specification (mil. spec.) 8625F, Type II, Class 1 in reference 4 of section 13.0 of this appendix. This anodic surface coating shall not be dyed or pigmented. Following anodization, the surfaces shall be sealed by immersion in boiling deionized water for not less than 15 minutes. Section 53.51(d)(2) of this chapter should also be consulted.

7.3.8 Sampling height. The sampler shall be equipped with legs, a stand, or other means to maintain the sampler in a stable, upright position and such that the center of the sample air entrance to the inlet, during sample collection, is maintained in a horizontal plane and is 2.0 ±0.2 meters above the floor or other horizontal supporting surface. Suitable bolt holes, brackets, tie-downs, or other means should be provided to facilitate mechanically securing the sample to the supporting surface to prevent toppling of the sampler due to wind.

7.4 Performance specifications.

7.4.1 Sample flow rate. Proper operation of the impactor requires that specific air velocities be

maintained through the device. Therefore, the design sample air flow rate through the inlet shall be 16.67 L/min (1.000 m³/hour) measured as actual volumetric flow rate at the temperature and pressure of the sample air entering the inlet.

7.4.2 Sample air flow rate control system. The sampler shall have a sample air flow rate control system which shall be capable of providing a sample air volumetric flow rate within the specified range, under section 7.4.1 of this appendix, for the specified filter, under section 6.0 of this appendix, at any atmospheric conditions specified, under section 7.4.7 of this appendix, at a filter pressure drop equal to that of a clean filter plus up to 75 cm water column (55 mm Hg), and over the specified range of supply line voltage, under section 7.4.15.1 of this appendix. This flow control system shall allow for operator adjustment of the operational flow rate of the sampler over a range of at least ±15 percent of the flow rate specified in section 7.4.1 of this appendix.

7.4.3 Sample flow rate regulation. The sample flow rate shall be regulated such that for the specified filter, under section 6.0 of this appendix, at any atmospheric conditions specified, under section 7.4.7 of this appendix, at a filter pressure drop equal to that of a clean filter plus up to 75 cm water column (55 mm Hg), and over the specified range of supply line voltage, under section 7.4.15.1 of this appendix, the flow rate is regulated as follows:

7.4.3.1 The volumetric flow rate, measured or averaged over intervals of not more than 5 minutes over a 24-hour period, shall not vary more than ±5 percent from the specified 16.67 L/min flow rate over the entire sample period.

7.4.3.2 The coefficient of variation (sample standard deviation divided by the mean) of the flow rate, measured over a 24-hour period, shall not be greater than 2 percent.

7.4.3.3 The amplitude of short-term flow rate pulsations, such as may originate from some types of vacuum pumps, shall be attenuated such that they do not cause significant flow measurement error or affect the collection of particles on the particle collection filter.

7.4.4 Flow rate cut off. The sampler's sample air flow rate control system shall terminate sample collection and stop all sample flow for the remainder of the sample period in the event that the sample flow rate deviates by more than 10 percent from the sampler design flow rate specified in section 7.4.1 of this appendix for more than 60 seconds. However, this sampler cut-off provision shall not apply during periods when the sampler is inoperative due to a temporary power interruption, and the elapsed time of the inoperative period shall not be included in the total sample time measured and reported by the sampler, under section 7.4.13 of this appendix.

7.4.5 Flow rate measurement.

7.4.5.1 The sampler shall provide a means to measure and indicate the instantaneous sample air flow rate, which shall be measured as volumetric flow rate at the temperature and pressure of the sample air entering the inlet, with an accuracy of ±2 percent. The measured flow rate shall be available for display to the sampler operator at any time in either sampling or standby modes, and the measurement shall be updated at least every 30 seconds. The sampler shall also provide a simple means by which the sampler operator can manually start the sample flow temporarily during non-sampling modes of operation, for the purpose of checking the sample flow rate or the flow rate measurement system.

7.4.5.2 During each sample period, the sampler's flow rate measurement system shall automatically monitor the sample volumetric flow rate, obtaining flow rate measurements at intervals of not greater than 30 seconds.

(a) Using these interval flow rate measurements, the sampler shall determine or calculate the following flow-related parameters, scaled in the specified engineering units:

(1) The instantaneous or interval-average flow rate, in L/min.

(2) The value of the average sample flow rate for the sample period, in L/min.

(3) The value of the coefficient of variation (sample standard deviation divided by the average) of the sample flow rate for the sample period, in percent.

(4) The occurrence of any time interval during the sample period in which the measured sample flow rate exceeds a range of ±5 percent of the average flow rate for the sample period for more than 5 minutes, in which case a warning flag indicator shall be set.

(5) The value of the integrated total sample volume for the sample period, in m³.

(b) Determination or calculation of these values shall properly exclude periods when the sampler is inoperative due to temporary interruption of electrical power, under section 7.4.13 of this appendix, or flow rate cut off, under section 7.4.4 of this appendix.

(c) These parameters shall be accessible to the sampler operator as specified in Table L-1 of section 7.4.19 of this appendix. In addition, it is strongly encouraged that the flow rate for each 5-minute interval during the sample period be available to the operator following the end of the sample period.

7.4.6 Leak test capability.

7.4.6.1 External leakage. The sampler shall include an external air leak-test capability consisting of components, accessory hardware, operator interface controls, a written procedure in the associated Operation/Instruction Manual, under section 7.4.18 of this appendix, and all other necessary functional capability to permit and facilitate the sampler operator to conveniently carry out a leak test of the sampler at a field monitoring site without additional equipment. The sampler components to be subjected to this leak test include all components and their interconnections in which external air leakage would or could cause an error in the sampler's measurement of the total volume of sample air that passes through the sample filter.

(a) The suggested technique for the operator to use for this leak test is as follows:

(1) Remove the sampler inlet and installs the flow rate measurement adapter supplied with the sampler, under section 7.3.6 of this appendix.

(2) Close the valve on the flow rate measurement adapter and use the sampler air pump to draw a partial vacuum in the sampler, including (at least) the impactor, filter holder assembly (filter in place), flow measurement device, and interconnections between these devices, of at least 55 mm Hg (75 cm water column), measured at a location downstream of the filter holder assembly.

(3) Plug the flow system downstream of these components to isolate the components under vacuum from the pump, such as with a built-in valve.

(4) Stop the pump.

(5) Measure the trapped vacuum in the sampler with a built-in pressure measuring device.

(6) (i) Measure the vacuum in the sampler with the built-in pressure measuring device again at a

later time at least 10 minutes after the first pressure measurement.

(i) **Caution:** Following completion of the test, the adaptor valve should be opened slowly to limit the flow rate of air into the sampler. Excessive air flow rate may blow oil out of the impactor.

(7) Upon completion of the test, open the adaptor valve, remove the adaptor and plugs, and restore the sampler to the normal operating configuration.

(b) The associated leak test procedure shall require that for successful passage of this test, the difference between the two pressure measurements shall not be greater than the number of mm of Hg specified for the sampler by the manufacturer, based on the actual internal volume of the sampler, that indicates a leak of less than 80 mL/min.

(c) Variations of the suggested technique or an alternative external leak test technique may be required for samplers whose design or configuration would make the suggested technique impossible or impractical. The specific proposed external leak test procedure, or particularly an alternative leak test technique, proposed for a particular candidate sampler may be described and submitted to the EPA for specific individual acceptability either as part of a reference or equivalent method application under part 53 of this chapter or in writing in advance of such an intended application under part 53 of this chapter.

7.4.6.2 Internal, filter bypass leakage. The sampler shall include an internal, filter bypass leak-check capability consisting of components, accessory hardware, operator interface controls, a written procedure in the Operation/Instruction Manual, and all other necessary functional capability to permit and facilitate the sampler operator to conveniently carry out a test for internal filter bypass leakage in the sampler at a field monitoring site without additional equipment. The purpose of the test is to determine that any portion of the sample flow rate that leaks past the sample filter without passing through the filter is insignificant relative to the design flow rate for the sampler.

(a) The suggested technique for the operator to use for this leak test is as follows:

(1) Carry out an external leak test as provided under section 7.4.6.1 of this appendix which indicates successful passage of the prescribed external leak test.

(2) Install a flow-impervious membrane material in the filter cassette, either with or without a filter, as appropriate, which effectively prevents air flow through the filter.

(3) Use the sampler air pump to draw a partial vacuum in the sampler, downstream of the filter holder assembly, of at least 55 mm Hg (75 cm water column).

(4) Plug the flow system downstream of the filter holder to isolate the components under vacuum from the pump, such as with a built-in valve.

(5) Stop the pump.

(6) Measure the trapped vacuum in the sampler with a built-in pressure measuring device.

(7) Measure the vacuum in the sampler with the built-in pressure measuring device again at a later time at least 10 minutes after the first pressure measurement.

(8) Remove the flow plug and membrane and restore the sampler to the normal operating configuration.

(b) The associated leak test procedure shall require that for successful passage of this test, the difference between the two pressure measurements shall not be greater than the number of mm of Hg specified for the sampler by the manufacturer,

based on the actual internal volume of the portion of the sampler under vacuum, that indicates a leak of less than 80 mL/min.

(c) Variations of the suggested technique or an alternative internal, filter bypass leak test technique may be required for samplers whose design or configuration would make the suggested technique impossible or impractical. The specific proposed internal leak test procedure, or particularly an alternative internal leak test technique proposed for a particular candidate sampler may be described and submitted to the EPA for specific individual acceptability either as part of a reference or equivalent method application under part 53 of this chapter or in writing in advance of such intended application under part 53 of this chapter.

7.4.7 Range of operational conditions. The sampler is required to operate properly and meet all requirements specified in this appendix over the following operational ranges.

7.4.7.1 Ambient temperature. -30 to +45 °C (Note: Although for practical reasons, the temperature range over which samplers are required to be tested under part 53 of this chapter is -20 to +40 °C, the sampler shall be designed to operate properly over this wider temperature range.).

7.4.7.2 Ambient relative humidity. 0 to 100 percent.

7.4.7.3 Barometric pressure range. 600 to 800 mm Hg.

7.4.8 Ambient temperature sensor. The sampler shall have capability to measure the temperature of the ambient air surrounding the sampler over the range of -30 to +45 °C, with a resolution of 0.1 °C and accuracy of ±2.0 °C, referenced as described in reference 3 in section 13.0 of this appendix, with and without maximum solar insolation.

7.4.8.1 The ambient temperature sensor shall be mounted external to the sampler enclosure and shall have a passive, naturally ventilated sun shield. The sensor shall be located such that the entire sun shield is at least 5 cm above the horizontal plane of the sampler case or enclosure (disregarding the inlet and downtube) and external to the vertical plane of the nearest side or protuberance of the sampler case or enclosure. The maximum temperature measurement error of the ambient temperature measurement system shall be less than 1.6 °C at 1 m/s wind speed and 1000 W/m² solar radiation intensity.

7.4.8.2 The ambient temperature sensor shall be of such a design and mounted in such a way as to facilitate its convenient dismounting and immersion in a liquid for calibration and comparison to the filter temperature sensor, under section 7.4.11 of this appendix.

7.4.8.3 This ambient temperature measurement shall be updated at least every 30 seconds during both sampling and standby (non-sampling) modes of operation. A visual indication of the current (most recent) value of the ambient temperature measurement, updated at least every 30 seconds, shall be available to the sampler operator during both sampling and standby (non-sampling) modes of operation, as specified in Table L-1 of section 7.4.19 of this appendix.

7.4.8.4 This ambient temperature measurement shall be used for the purpose of monitoring filter temperature deviation from ambient temperature, as required by section 7.4.11 of this appendix, and may be used for purposes of effecting filter temperature control, under section 7.4.10 of this appendix, or computation of volumetric flow rate, under sections 7.4.1 to 7.4.5 of this appendix, if appropriate.

7.4.8.5 Following the end of each sample period, the sampler shall report the maximum, minimum, and average temperature for the sample period, as specified in Table L-1 of section 7.4.19 of this appendix.

7.4.9 Ambient barometric sensor. The sampler shall have capability to measure the barometric pressure of the air surrounding the sampler over a range of 600 to 800 mm Hg referenced as described in reference 3 in section 13.0 of this appendix; also see part 53, subpart E of this chapter. This barometric pressure measurement shall have a resolution of 5 mm Hg and an accuracy of ±10 mm Hg and shall be updated at least every 30 seconds. A visual indication of the value of the current (most recent) barometric pressure measurement, updated at least every 30 seconds, shall be available to the sampler operator during both sampling and standby (non-sampling) modes of operation, as specified in Table L-1 of section 7.4.19 of this appendix. This barometric pressure measurement may be used for purposes of computation of volumetric flow rate, under sections 7.4.1 to 7.4.5 of this appendix, if appropriate. Following the end of a sample period, the sampler shall report the maximum, minimum, and mean barometric pressures for the sample period, as specified in Table L-1 of section 7.4.19 of this appendix.

7.4.10 Filter temperature control (sampling and post-sampling). The sampler shall provide a means to limit the temperature rise of the sample filter (all sample filters for sequential samplers), from insolation and other sources, to no more 5 °C above the temperature of the ambient air surrounding the sampler, during both sampling and post-sampling periods of operation. The post-sampling period is the non-sampling period between the end of the active sampling period and the time of retrieval of the sample filter by the sampler operator.

7.4.11 Filter temperature sensor(s).

7.4.11.1 The sampler shall have the capability to monitor the temperature of the sample filter (all sample filters for sequential samplers) over the range of -30 to +45 °C during both sampling and non-sampling periods. While the exact location of this temperature sensor is not explicitly specified, the filter temperature measurement system must demonstrate agreement, within 1 °C, with a test temperature sensor located within 1 cm of the center of the filter downstream of the filter during both sampling and non-sampling modes, as specified in the filter temperature measurement test described in part 53, subpart E of this chapter. This filter temperature measurement shall have a resolution of 0.1 °C and accuracy of ±1.0 °C, referenced as described in reference 3 in section 13.0 of this appendix. This temperature sensor shall be of such a design and mounted in such a way as to facilitate its reasonably convenient dismounting and immersion in a liquid for calibration and comparison to the ambient temperature sensor under section 7.4.8 of this appendix.

7.4.11.2 The filter temperature measurement shall be updated at least every 30 seconds during both sampling and standby (non-sampling) modes of operation. A visual indication of the current (most recent) value of the filter temperature measurement, updated at least every 30 seconds, shall be available to the sampler operator during both sampling and standby (non-sampling) modes of operation, as specified in Table L-1 of section 7.4.19 of this appendix.

7.4.11.3 For sequential samplers, the temperature of each filter shall be measured individually unless it can be shown, as specified in the filter

temperature measurement test described in § 53.57 of this chapter, that the temperature of each filter can be represented by fewer temperature sensors.

7.4.11.4 The sampler shall also provide a warning flag indicator following any occurrence in which the filter temperature (any filter temperature for sequential samplers) exceeds the ambient temperature by more than 5 °C for more than 30 consecutive minutes during either the sampling or post-sampling periods of operation, as specified in Table L-1 of section 7.4.19 of this appendix, under section 10.12 of this appendix, regarding sample validity when a warning flag occurs. It is further recommended (not required) that the sampler be capable of recording the maximum differential between the measured filter temperature and the ambient temperature and its time and date of occurrence during both sampling and post-sampling (non-sampling) modes of operation and providing for those data to be accessible to the sampler operator following the end of the sample period, as suggested in Table L-1 of section 7.4.19 of this appendix.

7.4.12 Clock/timer system.

(a) The sampler shall have a programmable real-time clock timing/control system that:

(1) Is capable of maintaining local time and date, including year, month, day-of-month, hour, minute, and second to an accuracy of ± 1.0 minute per month.

(2) Provides a visual indication of the current system time, including year, month, day-of-month, hour, and minute, updated at least each minute, for operator verification.

(3) Provides appropriate operator controls for setting the correct local time and date.

(4) Is capable of starting the sample collection period and sample air flow at a specific, operator-settable time and date, and stopping the sample air flow and terminating the sampler collection period 24 hours (1440 minutes) later, or at a specific, operator-settable time and date.

(b) These start and stop times shall be readily settable by the sampler operator to within ± 1.0 minute. The system shall provide a visual indication of the current start and stop time settings, readable to ± 1.0 minute, for verification by the operator, and the start and stop times shall also be available via the data output port, as specified in Table L-1 of section 7.4.19 of this appendix. Upon execution of a programmed sample period start, the sampler shall automatically reset all sample period information and warning flag indications pertaining to a previous sample period. Refer also to section 7.4.15.4 of this appendix regarding retention of current date and time and programmed start and stop times during a temporary electrical power interruption.

7.4.13 *Sample time determination.* The sampler shall be capable of determining the elapsed sample collection time for each PM_{2.5} sample, accurate to within ± 1.0 minute, measured as the time between the start of the sampling period, under section 7.4.12 of this appendix and the termination of the sample period, under section 7.4.12 of this appendix or section 7.4.4 of this appendix. This elapsed sample time shall not include periods when the sampler is inoperative due to a temporary interruption of electrical power, under section 7.4.15.4 of this appendix. In the event that the

elapsed sample time determined for the sample period is not within the range specified for the required sample period in section 3.3 of this appendix, the sampler shall set a warning flag indicator. The date and time of the start of the sample period, the value of the elapsed sample time for the sample period, and the flag indicator status shall be available to the sampler operator following the end of the sample period, as specified in Table L-1 of section 7.4.19 of this appendix.

7.4.14 *Outdoor environmental enclosure.* The sampler shall have an outdoor enclosure (or enclosures) suitable to protect the filter and other non-weatherproof components of the sampler from precipitation, wind, dust, extremes of temperature and humidity; to help maintain temperature control of the filter (or filters, for sequential samplers); and to provide reasonable security for sampler components and settings.

7.4.15 Electrical power supply.

7.4.15.1 The sampler shall be operable and function as specified herein when operated on an electrical power supply voltage of 105 to 125 volts AC (RMS) at a frequency of 59 to 61 Hz. Optional operation as specified at additional power supply voltages and/or frequencies shall not be precluded by this requirement.

7.4.15.2 The design and construction of the sampler shall comply with all applicable National Electrical Code and Underwriters Laboratories electrical safety requirements.

7.4.15.3 The design of all electrical and electronic controls shall be such as to provide reasonable resistance to interference or malfunction from ordinary or typical levels of stray electromagnetic fields (EMF) as may be found at various monitoring sites and from typical levels of electrical transients or electronic noise as may often or occasionally be present on various electrical power lines.

7.4.15.4 In the event of temporary loss of electrical supply power to the sampler, the sampler shall not be required to sample or provide other specified functions during such loss of power, except that the internal clock/timer system shall maintain its local time and date setting within ± 1 minute per week, and the sampler shall retain all other time and programmable settings and all data required to be available to the sampler operator following each sample period for at least 7 days without electrical supply power. When electrical power is absent at the operator-set time for starting a sample period or is interrupted during a sample period, the sampler shall automatically start or resume sampling when electrical power is restored, if such restoration of power occurs before the operator-set stop time for the sample period.

7.4.15.5 The sampler shall have the capability to record and retain a record of the year, month, day-of-month, hour, and minute of the start of each power interruption of more than 1 minute duration, up to 10 such power interruptions per sample period. (More than 10 such power interruptions shall invalidate the sample, except where an exceedance is measured, under section 3.3 of this appendix.) The sampler shall provide for these power interruption data to be available to the sampler operator following the end of the sample period, as specified in Table L-1 of section 7.4.19 of this appendix.

7.4.16 Control devices and operator interface.

The sampler shall have mechanical, electrical, or electronic controls, control devices, electrical or electronic circuits as necessary to provide the timing, flow rate measurement and control, temperature control, data storage and computation, operator interface, and other functions specified. Operator-accessible controls, data displays, and interface devices shall be designed to be simple, straightforward, reliable, and easy to learn, read, and operate under field conditions. The sampler shall have provision for operator input and storage of up to 64 characters of numeric (or alphanumeric) data for purposes of site, sampler, and sample identification. This information shall be available to the sampler operator for verification and change and for output via the data output port along with other data following the end of a sample period, as specified in Table L-1 of section 7.4.19 of this appendix. All data required to be available to the operator following a sample collection period or obtained during standby mode in a post-sampling period shall be retained by the sampler until reset, either manually by the operator or automatically by the sampler upon initiation of a new sample collection period.

7.4.17 *Data output port requirement.* The sampler shall have a standard RS-232C data output connection through which digital data may be exported to an external data storage or transmission device. All information which is required to be available at the end of each sample period shall be accessible through this data output connection. The information that shall be accessible through this output port is summarized in Table L-1 of section 7.4.19 of this appendix. Since no specific format for the output data is provided, the sampler manufacturer or vendor shall make available to sampler purchasers appropriate computer software capable of receiving exported sampler data and correctly translating the data into a standard spreadsheet format and optionally any other formats as may be useful to sampler users. This requirement shall not preclude the sampler from offering other types of output connections in addition to the required RS-232C port.

7.4.18 *Operation/instruction manual.* The sampler shall include an associated comprehensive operation or instruction manual, as required by part 53 of this chapter, which includes detailed operating instructions on the setup, operation, calibration, and maintenance of the sampler. This manual shall provide complete and detailed descriptions of the operational and calibration procedures prescribed for field use of the sampler and all instruments utilized as part of this reference method. The manual shall include adequate warning of potential safety hazards that may result from normal use or malfunction of the method and a description of necessary safety precautions. The manual shall also include a clear description of all procedures pertaining to installation, operation, periodic and corrective maintenance, and troubleshooting, and shall include parts identification diagrams.

7.4.19 *Data reporting requirements.* The various information that the sampler is required to provide and how it is to be provided is summarized in the following Table L-1.

TABLE L-1.—SUMMARY OF INFORMATION TO BE PROVIDED BY THE SAMPLER

Information to be provided	Appendix L section reference	Availability				Format	
		Anytime ¹	End of period ²	Visual display ³	Data output ⁴	Digital reading ⁵	Units
Flow rate, 30-second maximum interval.	7.4.5.1	✓	✓	*	XX.X	L/min
Flow rate, average for the sample period.	7.4.5.2	*	✓	*	✓	XX.X	L/min
Flow rate, CV, for sample period.	7.4.5.2	*	✓	*	✓●	XX.X	%
Flow rate, 5-min. average out of spec. (FLAG ⁶).	7.4.5.2	✓	✓	✓	✓●	On/Off	
Sample volume, total	7.4.5.2	*	✓	✓	✓●	XX.X	m ³
Temperature, ambient, 30-second interval.	7.4.8	✓	✓	XX.X	°C
Temperature, ambient, min., max., average for the sample period.	7.4.8	*	✓	✓	✓●	XX.X	°C
Baro pressure, ambient, 30-second interval.	7.4.9	✓	✓	XXX	mm Hg
Baro pressure, ambient, min., max., average for the sample period.	7.4.9	*	✓	✓	✓●	XXX	mm Hg
Filter temperature, 30-second interval.	7.4.11	✓	✓	XX.X	°C
Filter temperature differential, 30-second interval, out of spec. (FLAG ⁶).	7.4.11	*	✓	✓	✓●	On/Off	
Filter temperature, maximum differential from ambient, date, time of occurrence.	7.4.11	*	*	*	*	X.X, YY/MM/DD HH:mm.	°C, Yr./Mon./Day Hrs. min
Date and time	7.4.12	✓	✓	YY/MM/DD HH:mm	Yr./Mon./Day Hrs. min
Sample start and stop time settings.	7.4.12	✓	✓	✓	✓	YY/MM/DD HH:mm	Yr./Mon./Day Hrs. min
Sample period start time.	7.4.12	✓	✓	✓●	YYYY/MM/DD HH:mm	Yr./Mon./Day Hrs. min
Elapsed sample time	7.4.13	*	✓	✓	✓●	HH:mm	Hrs. min
Elapsed sample time, out of spec. (FLAG ⁶).	7.4.13	✓	✓	✓●	On/Off	
Power interruptions >1 min., start time of first 10.	7.4.15.5	*	✓	*	✓	1HH:mm, 2HH:mm, etc	Hrs. min
User-entered information, such as sampler and site identification.	7.4.16	✓	✓	✓	✓●	As entered	

✓ Provision of this information is required.

Provision of this information is optional. If information related to the entire sample period is optionally provided prior to the end of the sample period, the value provided should be the value calculated for the portion of the sampler period completed up to the time the information is provided.

● Indicates that this information is also required to be provided to the AIRS data bank; see §§ 58.26 and 58.35 of this chapter.

¹ Information is required to be available to the operator at any time the sampler is operating, whether sampling or not.

² Information relates to the entire sampler period and must be provided following the end of the sample period until reset manually by the operator or automatically by the sampler upon the start of a new sample period.

³ Information shall be available to the operator visually.

⁴ Information is to be available as digital data at the sampler's data output port specified in section 7.4.16 of this appendix following the end of the sample period until reset manually by the operator or automatically by the sampler upon the start of a new sample period.

⁵ Digital readings, both visual and data output, shall have not less than the number of significant digits and resolution specified.

⁶ Flag warnings may be displayed to the operator by a single-flag indicator or each flag may be displayed individually. Only a set (on) flag warning must be indicated; an off (unset) flag may be indicated by the absence of a flag warning. Sampler users should refer to section 10.12 of this appendix regarding the validity of samples for which the sampler provided an associated flag warning.

8.0 *Filter Weighing.* See reference 2 in section 13.0 of this appendix, for additional, more detailed guidance.

8.1 *Analytical balance.* The analytical balance used to weigh filters must be suitable for weighing the type and size of filters specified, under section 6.0 of this appendix, and have a readability of ±1

µg. The balance shall be calibrated as specified by the manufacturer at installation and recalibrated immediately prior to each weighing session. See

US EPA ARCHIVE DOCUMENT

reference 2 in section 13.0 of this appendix for additional guidance.

8.2 *Filter conditioning.* All sample filters used shall be conditioned immediately before both the pre- and post-sampling weighings as specified below. See reference 2 in section 13.0 of this appendix for additional guidance.

8.2.1 *Mean temperature.* 20 - 23 °C.

8.2.2 *Temperature control.* ± 2 °C over 24 hours.

8.2.3 *Mean humidity.* Generally, 30–40 percent relative humidity; however, where it can be shown that the mean ambient relative humidity during sampling is less than 30 percent, conditioning is permissible at a mean relative humidity within ± 5 relative humidity percent of the mean ambient relative humidity during sampling, but not less than 20 percent.

8.2.4 *Humidity control.* ± 5 relative humidity percent over 24 hours.

8.2.5 *Conditioning time.* Not less than 24 hours.

8.3 *Weighing procedure.*

8.3.1 New filters should be placed in the conditioning environment immediately upon arrival and stored there until the pre-sampling weighing. See reference 2 in section 13.0 of this appendix for additional guidance.

8.3.2 The analytical balance shall be located in the same controlled environment in which the filters are conditioned. The filters shall be weighed immediately following the conditioning period without intermediate or transient exposure to other conditions or environments.

8.3.3 Filters must be conditioned at the same conditions (humidity within ± 5 relative humidity percent) before both the pre- and post-sampling weighings.

8.3.4 Both the pre- and post-sampling weighings should be carried out on the same analytical balance, using an effective technique to neutralize static charges on the filter, under reference 2 in section 13.0 of this appendix. If possible, both weighings should be carried out by the same analyst.

8.3.5 The pre-sampling (tare) weighing shall be within 30 days of the sampling period.

8.3.6 The post-sampling conditioning and weighing shall be completed within 240 hours (10 days) after the end of the sample period, unless the filter sample is maintained at 4 °C or less during the entire time between retrieval from the sampler and the start of the conditioning, in which case the period shall not exceed 30 days. Reference 2 in section 13.0 of this appendix has additional guidance on transport of cooled filters.

8.3.7 *Filter blanks.*

8.3.7.1 New field blank filters shall be weighed along with the pre-sampling (tare) weighing of each lot of PM_{2.5} filters. These blank filters shall be transported to the sampling site, installed in the sampler, retrieved from the sampler without sampling, and reweighed as a quality control check.

8.3.7.2 New laboratory blank filters shall be weighed along with the pre-sampling (tare) weighing of each set of PM_{2.5} filters. These laboratory blank filters should remain in the laboratory in protective containers during the field sampling and should be reweighed as a quality control check.

8.3.8 Additional guidance for proper filter weighing and related quality assurance activities is provided in reference 2 in section 13.0 of this appendix.

9.0 *Calibration.* Reference 2 in section 13.0 of this appendix contains additional guidance.

9.1 *General requirements.*

9.1.1 Multipoint calibration and single-point verification of the sampler's flow rate measurement

device must be performed periodically to establish and maintain traceability of subsequent flow measurements to a flow rate standard.

9.1.2 An authoritative flow rate standard shall be used for calibrating or verifying the sampler's flow rate measurement device with an accuracy of ± 2 percent. The flow rate standard shall be a separate, stand-alone device designed to connect to the flow rate measurement adapter, Figure L-30 of this appendix. This flow rate standard must have its own certification and be traceable to a National Institute of Standards and Technology (NIST) primary standard for volume or flow rate. If adjustments to the sampler's flow rate measurement system calibration are to be made in conjunction with an audit of the sampler's flow measurement system, such adjustments shall be made following the audit. Reference 2 in section 13.0 of this appendix contains additional guidance.

9.1.3 The sampler's flow rate measurement device shall be re-calibrated after electromechanical maintenance or transport of the sampler.

9.2 *Flow rate calibration/verification procedure.*

9.2.1 PM_{2.5} samplers may employ various types of flow control and flow measurement devices. The specific procedure used for calibration or verification of the flow rate measurement device will vary depending on the type of flow rate controller and flow rate measurement employed. Calibration shall be in terms of actual ambient volumetric flow rates (Q^a), measured at the sampler's inlet downtube. The generic procedure given here serves to illustrate the general steps involved in the calibration of a PM_{2.5} sampler. The sampler operation/instruction manual required under section 7.4.18 of this appendix and the Quality Assurance Handbook in reference 2 in section 13.0 of this appendix provide more specific and detailed guidance for calibration.

9.2.2 The flow rate standard used for flow rate calibration shall have its own certification and be traceable to a NIST primary standard for volume or flow rate. A calibration relationship for the flow rate standard, e.g., an equation, curve, or family of curves relating actual flow rate (Q_a) to the flow rate indicator reading, shall be established that is accurate to within 2 percent over the expected range of ambient temperatures and pressures at which the flow rate standard may be used. The flow rate standard must be re-calibrated or re-verified at least annually.

9.2.3 The sampler flow rate measurement device shall be calibrated or verified by removing the sampler inlet and connecting the flow rate standard to the sampler's downtube in accordance with the operation/instruction manual, such that the flow rate standard accurately measures the sampler's flow rate. The sampler operator shall first carry out a sampler leak check and confirm that the sampler passes the leak test and then verify that no leaks exist between the flow rate standard and the sampler.

9.2.4 The calibration relationship between the flow rate (in actual L/min) indicated by the flow rate standard and by the sampler's flow rate measurement device shall be established or verified in accordance with the sampler operation/instruction manual. Temperature and pressure corrections to the flow rate indicated by the flow rate standard may be required for certain types of flow rate standards. Calibration of the sampler's flow rate measurement device shall consist of at least three separate flow rate measurements (multipoint calibration) evenly spaced within the range of -10 percent to +10 percent of the sampler's operational flow rate, section 7.4.1 of this

appendix. Verification of the sampler's flow rate shall consist of one flow rate measurement at the sampler's operational flow rate. The sampler operation/instruction manual and reference 2 in section 13.0 of this appendix provide additional guidance.

9.2.5 If during a flow rate verification the reading of the sampler's flow rate indicator or measurement device differs by ± 2 percent or more from the flow rate measured by the flow rate standard, a new multipoint calibration shall be performed and the flow rate verification must then be repeated.

9.2.6 Following the calibration or verification, the flow rate standard shall be removed from the sampler and the sampler inlet shall be reinstalled. Then the sampler's normal operating flow rate (in L/min) shall be determined with a clean filter in place. If the flow rate indicated by the sampler differs by ± 2 percent or more from the required sampler flow rate, the sampler flow rate must be adjusted to the required flow rate, under section 7.4.1 of this appendix.

9.3 Periodic calibration or verification of the calibration of the sampler's ambient temperature, filter temperature, and barometric pressure measurement systems is also required. Reference 3 of section 13.0 of this appendix contains additional guidance.

10.0 *PM_{2.5} Measurement Procedure* The detailed procedure for obtaining valid PM_{2.5} measurements with each specific sampler designated as part of a reference method for PM_{2.5} under part 53 of this chapter shall be provided in the sampler-specific operation or instruction manual required by section 7.4.18 of this appendix. Supplemental guidance is provided in section 2.12 of the Quality Assurance Handbook listed in reference 2 in section 13.0 of this appendix. The generic procedure given here serves to illustrate the general steps involved in the PM_{2.5} sample collection and measurement, using a PM_{2.5} reference method sampler.

10.1 The sampler shall be set up, calibrated, and operated in accordance with the specific, detailed guidance provided in the specific sampler's operation or instruction manual and in accordance with a specific quality assurance program developed and established by the user, based on applicable supplementary guidance provided in reference 2 in section 13.0 of this appendix.

10.2 Each new sample filter shall be inspected for correct type and size and for pinholes, particles, and other imperfections. Unacceptable filters should be discarded. A unique identification number shall be assigned to each filter, and an information record shall be established for each filter. If the filter identification number is not or cannot be marked directly on the filter, alternative means, such as a number-identified storage container, must be established to maintain positive filter identification.

10.3 Each filter shall be conditioned in the conditioning environment in accordance with the requirements specified in section 8.2 of this appendix.

10.4 Following conditioning, each filter shall be weighed in accordance with the requirements specified in section 8.0 of this appendix and the presampling weight recorded with the filter identification number.

10.5 A numbered and preweighed filter shall be installed in the sampler following the instructions provided in the sampler operation or instruction manual.

10.6 The sampler shall be checked and prepared for sample collection in accordance with

instructions provided in the sampler operation or instruction manual and with the specific quality assurance program established for the sampler by the user.

10.7 The sampler's timer shall be set to start the sample collection at the beginning of the desired sample period and stop the sample collection 24 hours later.

10.8 Information related to the sample collection (site location or identification number, sample date, filter identification number, and sampler model and serial number) shall be recorded and, if appropriate, entered into the sampler.

10.9 The sampler shall be allowed to collect the PM_{2.5} sample during the set 24-hour time period.

10.10 Within 96 hours of the end of the sample collection period, the filter, while still contained in the filter cassette, shall be carefully removed from the sampler, following the procedure provided in the sampler operation or instruction manual and the quality assurance program, and placed in a protective container. This protective container shall be made of metal and contain no loose material that could be transferred to the filter. The protective container shall hold the filter cassette securely such that the cover shall not come in contact with the filter's surfaces. Reference 2 in section 13.0 of this appendix contains additional information.

10.11 The total sample volume in actual m³ for the sampling period and the elapsed sample time shall be obtained from the sampler and recorded in accordance with the instructions provided in the sampler operation or instruction manual. All sampler warning flag indications and other information required by the local quality assurance program shall also be recorded.

10.12 All factors related to the validity or representativeness of the sample, such as sampler tampering or malfunctions, unusual meteorological conditions, construction activity, fires or dust storms, etc. shall be recorded as required by the local quality assurance program. The occurrence of a flag warning during a sample period shall not

necessarily indicate an invalid sample but rather shall indicate the need for specific review of the QC data by a quality assurance officer to determine sample validity.

10.13 After retrieval from the sampler, the exposed filter containing the PM_{2.5} sample should be transported to the filter conditioning environment as soon as possible ideally to arrive at the conditioning environment within 24 hours for conditioning and subsequent weighing. During the period between filter retrieval from the sampler and the start of the conditioning, the filter shall be maintained as cool as practical and continuously protected from exposure to temperatures over 25 °C. See section 8.3.6 of this appendix regarding time limits for completing the post-sampling weighing. See reference 2 in section 13.0 of this appendix for additional guidance on transporting filter samplers to the conditioning and weighing laboratory.

10.14. The exposed filter containing the PM_{2.5} sample shall be re-conditioned in the conditioning environment in accordance with the requirements specified in section 8.2 of this appendix.

10.15. The filter shall be reweighed immediately after conditioning in accordance with the requirements specified in section 8.0 of this appendix, and the postsampling weight shall be recorded with the filter identification number.

10.16 The PM_{2.5} concentration shall be calculated as specified in section 12.0 of this appendix.

11.0 *Sampler Maintenance*

The sampler shall be maintained as described by the sampler's manufacturer in the sampler-specific operation or instruction manual required under section 7.4.18 of this appendix and in accordance with the specific quality assurance program developed and established by the user based on applicable supplementary guidance provided in reference 2 in section 13.0 of this appendix.

12.0 *Calculations*

12.1 (a) The PM_{2.5} concentration is calculated as:

$$PM_{2.5} = (W_f - W_i)/V_a$$

where:

PM_{2.5} = mass concentration of PM_{2.5}, µg/m³;

W_f, W_i = final and initial weights, respectively, of the filter used to collect the PM_{2.5} particle sample, µg;

V_a = total air volume sampled in actual volume units, as provided by the sampler, m³.

(b) Note: Total sample time must be between 1,380 and 1,500 minutes (23 and 25 hrs) for a fully valid PM_{2.5} sample; however, see also section 3.3 of this appendix.

13.0 *References*

1. Quality Assurance Handbook for Air Pollution Measurement Systems, Volume I, Principles. EPA/600/R-94/038a, April 1994. Available from CERL, ORD Publications, U.S. Environmental Protection Agency, 26 West Martin Luther King Drive, Cincinnati, Ohio 45268.

2. Copies of section 2.12 of the Quality Assurance Handbook for Air Pollution Measurement Systems, Volume II, Ambient Air Specific Methods, EPA/600/R-94/038b, are available from Department E (MD-77B), U.S. EPA, Research Triangle Park, NC 27711.

3. Quality Assurance Handbook for Air Pollution Measurement Systems, Volume IV: Meteorological Measurements, (Revised Edition) EPA/600/R-94/038d, March, 1995. Available from CERL, ORD Publications, U.S. Environmental Protection Agency, 26 West Martin Luther King Drive, Cincinnati, Ohio 45268.

4. Military standard specification (mil. spec.) 8625F, Type II, Class 1 as listed in Department of Defense Index of Specifications and Standards (DODISS), available from DODSSP-Customer Service, Standardization Documents Order Desk, 700 Robbins Avenue, Building 4D, Philadelphia, PA 1911-5094.

14.0 *Figures L-1 through L-30 to Appendix L.*

FIGURE L-1. PM2.5 SAMPLER, ASSEMBLY

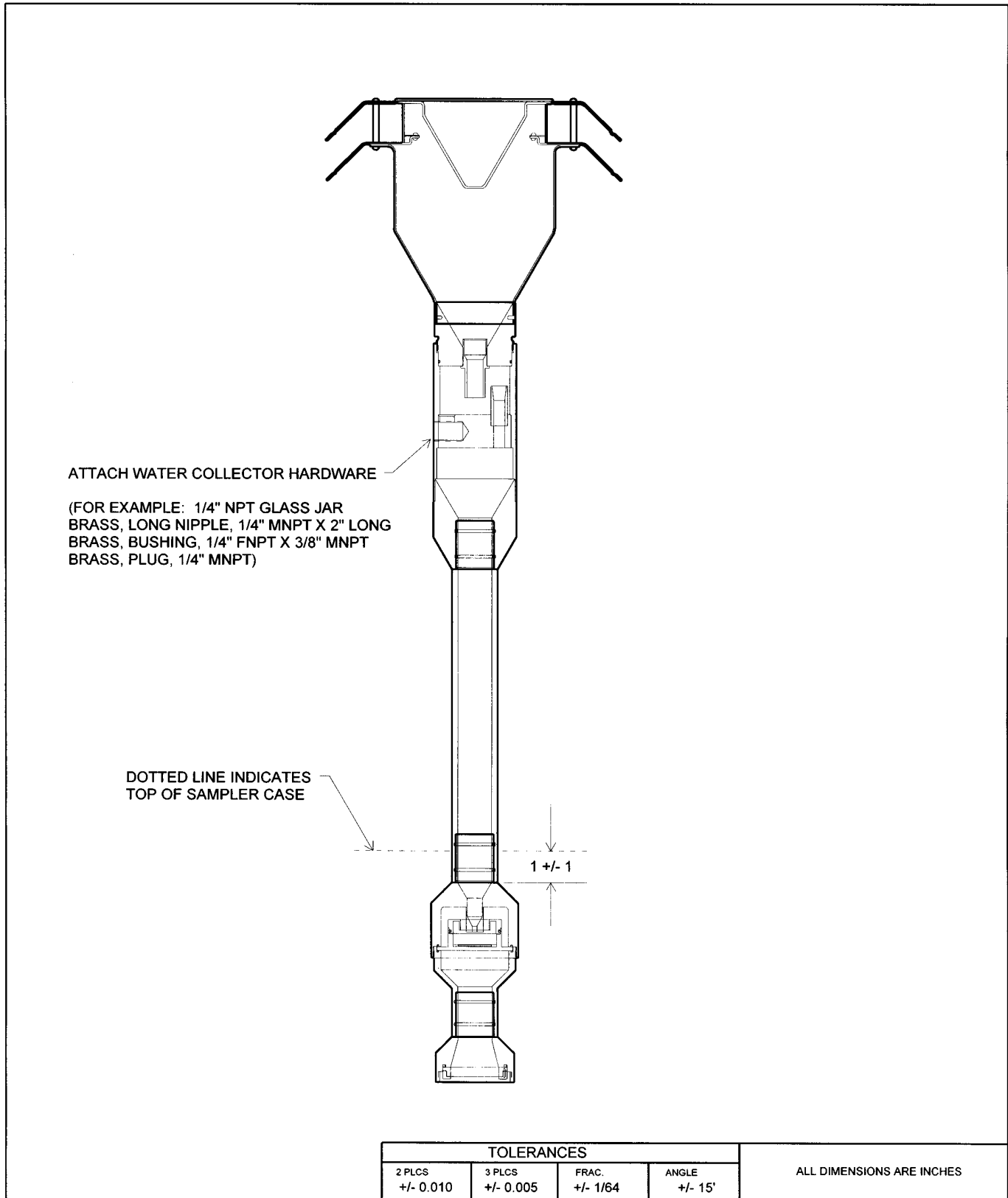

FIGURE L-2. 10-MICRON INLET, ASSEMBLY

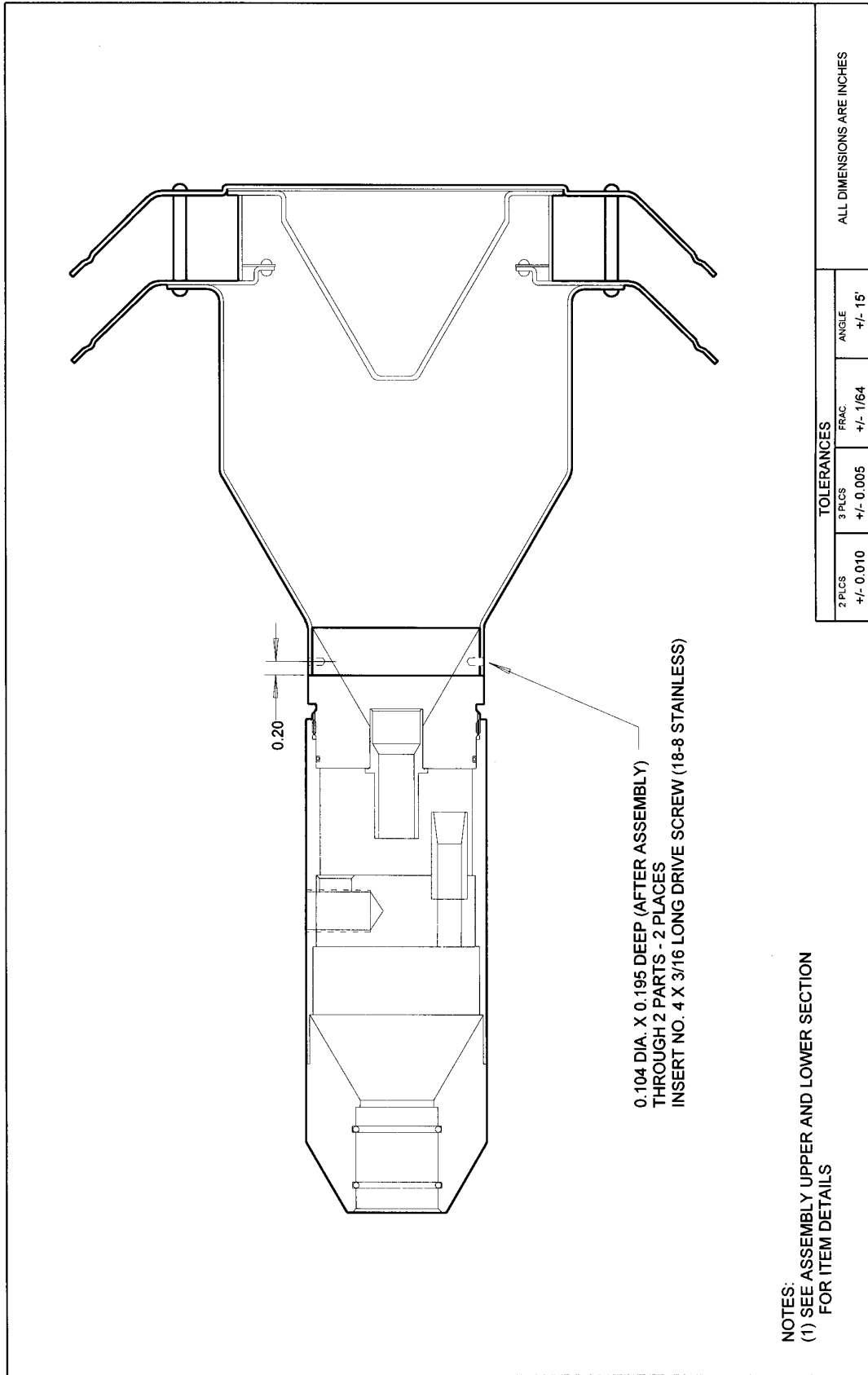
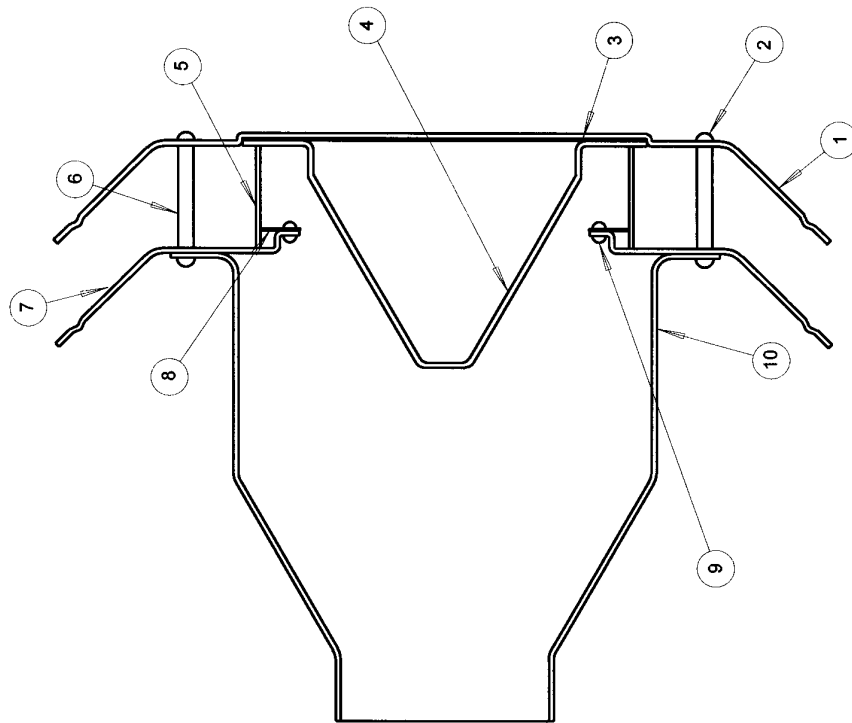

FIGURE L-3. 10-MICRON ASSEMBLY, UPPER SECTION

ITEM	DESCRIPTION	QTY.
1	10-MICRON INLET, TOP (FIGURE L-5)	1
2	6-32 X 3/8 RD. HEAD SCREW	8
3	10-MICRON GASKET (FIGURE L-6)	1
4	10-MICRON WIND DEFLECTOR (FIGURE L-7)	1
5	10-MICRON SCREEN (FIGURE L-8)	1
6	10-MICRON SPACER (FIGURE L-9)	4
7	10-MICRON INLET, LOWER (FIGURE L-11)	1
8	10-MICRON RAIN DEFLECTOR (FIGURE L-10)	1
9	1/8 D/A. RIVET	6
10	10-MICRON NOZZLE ENTRY SECT. (FIGURE L-12)	1



NOTES:

- (1) AFFIX ITEM 3 (10-MICRON GASKET) TO ITEMS 1 (10-MICRON INLET, TOP) AND 4 (10-MICRON WIND DEFLECTOR) USING APPROPRIATE ADHESIVE

TOLERANCES		
2 PLCS	3 PLCS	ANGLE
+/- 0.010	+/- 1/64	+/- 15'

ALL DIMENSIONS ARE INCHES

FIGURE L-4. 10-MICRON ASSEMBLY, LOWER SECTION

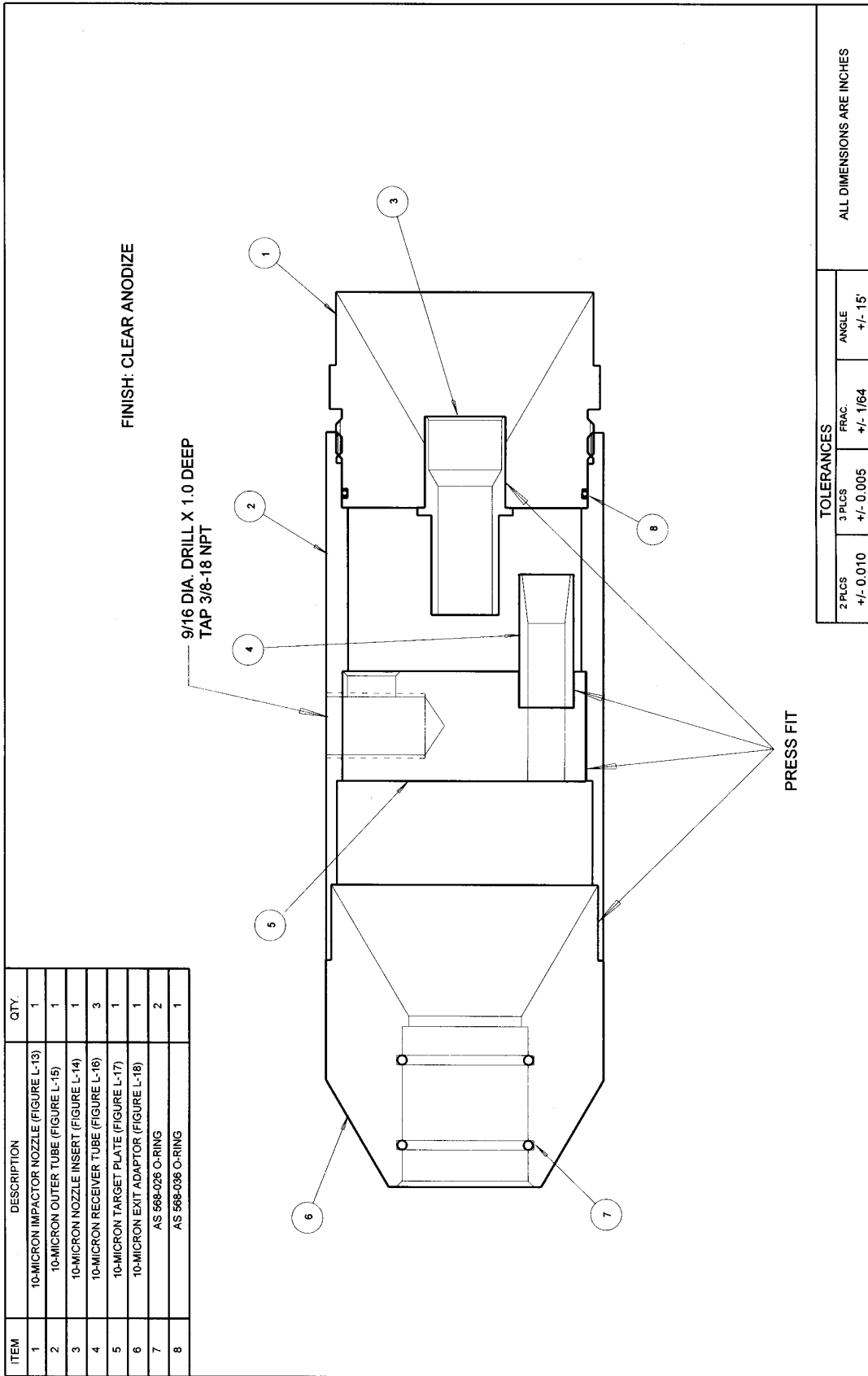

FIGURE L-5. 10-MICRON INLET, TOP

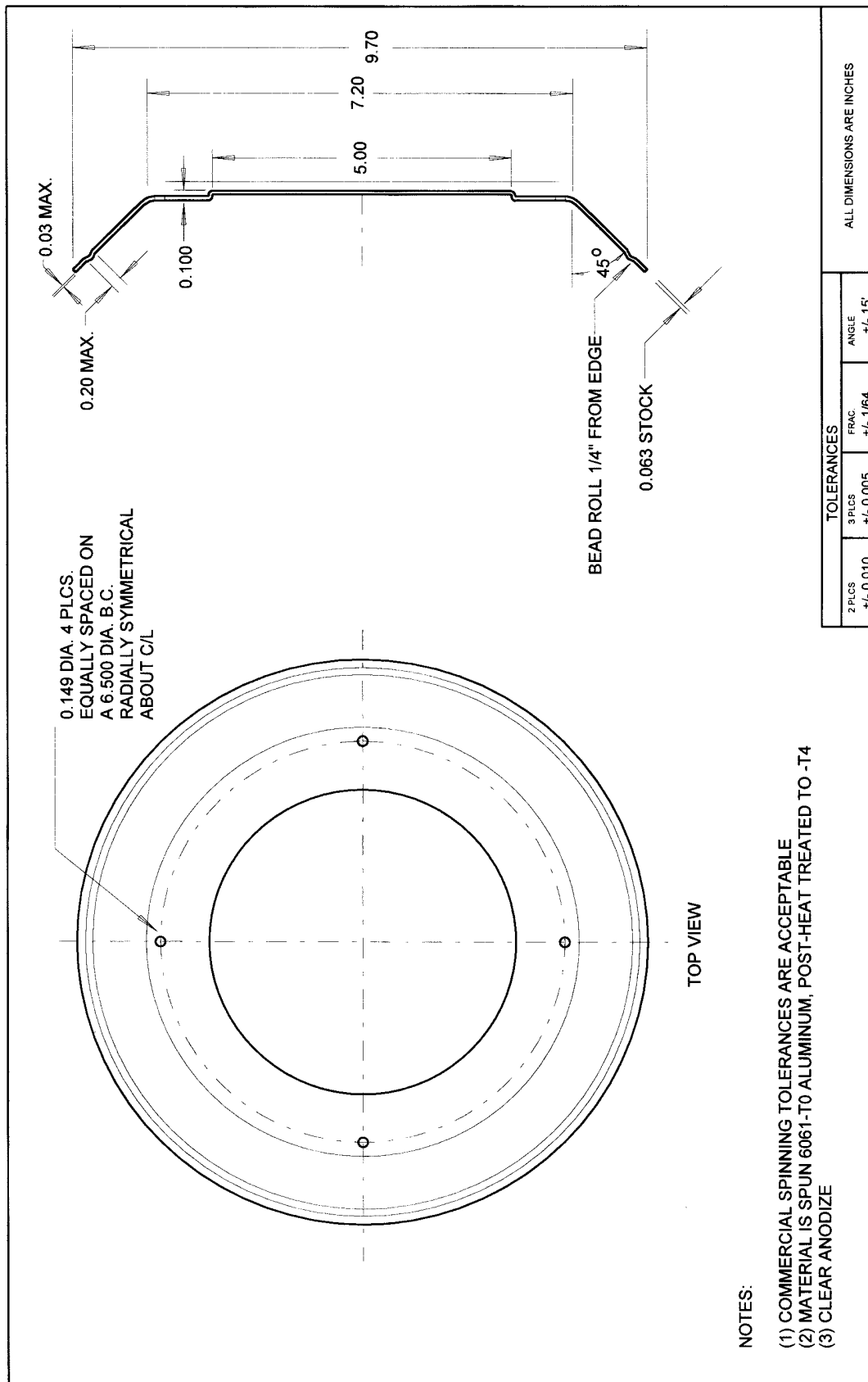

FIGURE L-6. 10-MICRON GASKET

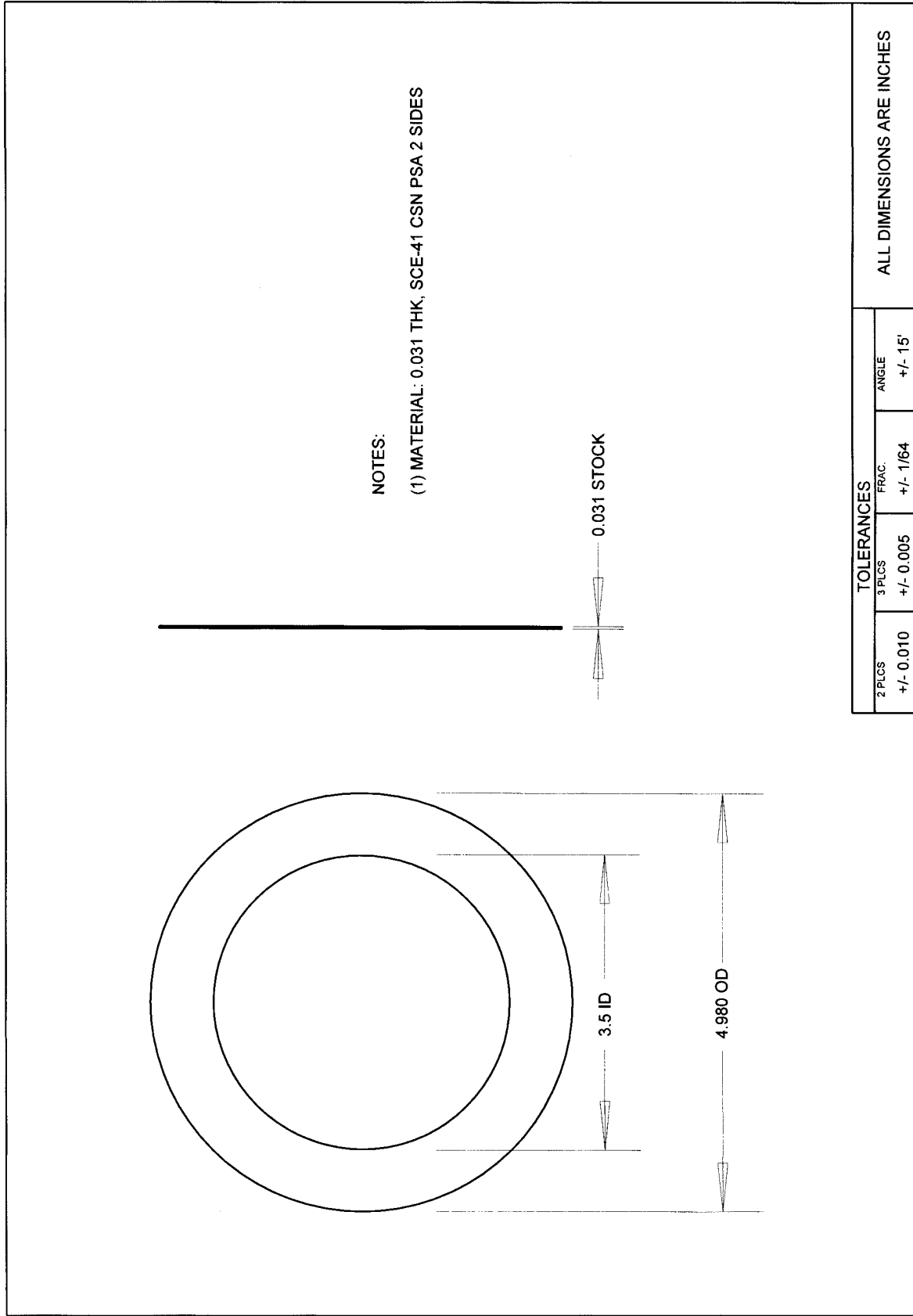

FIGURE L-7. 10-MICRON WIND DEFLECTOR

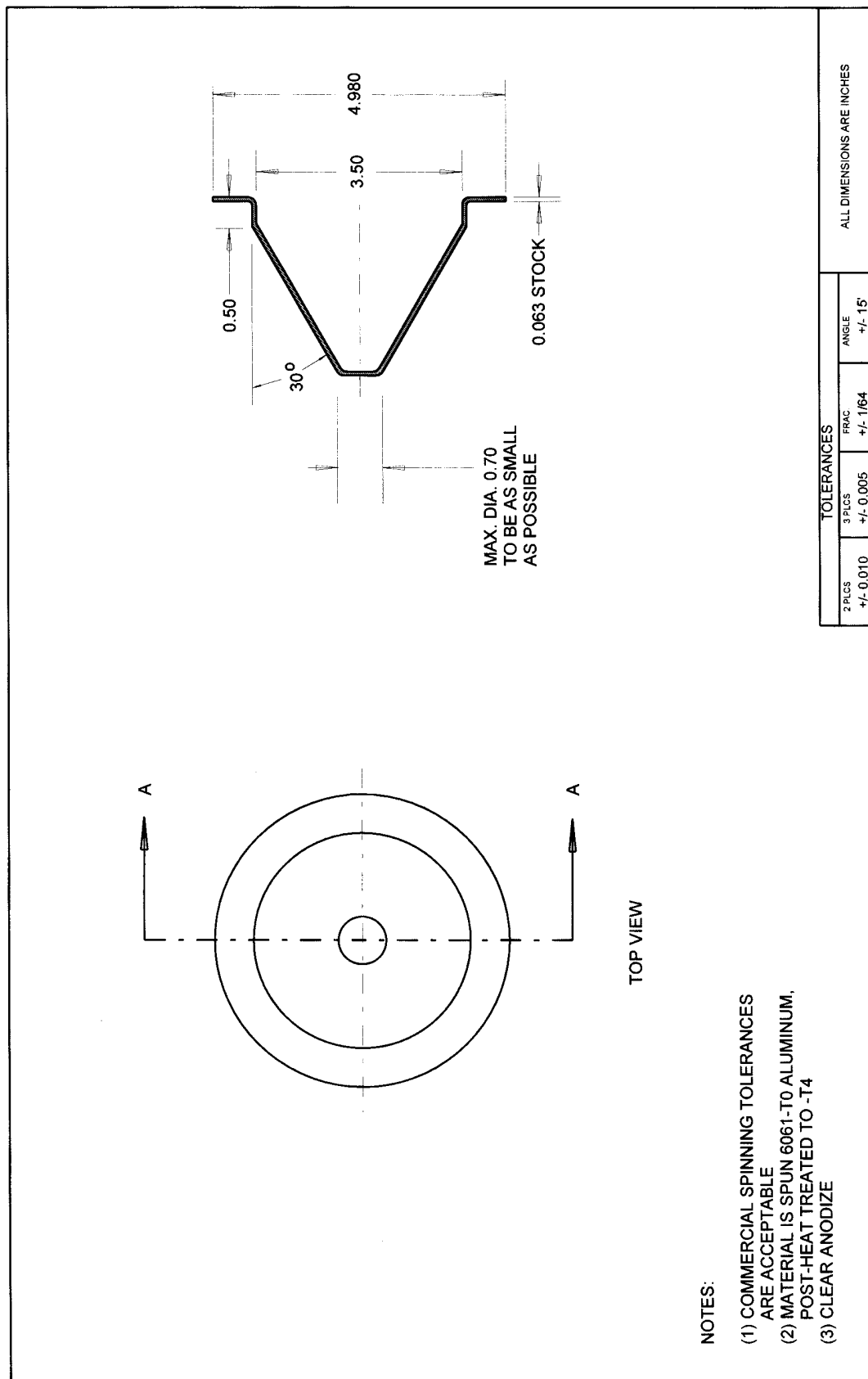
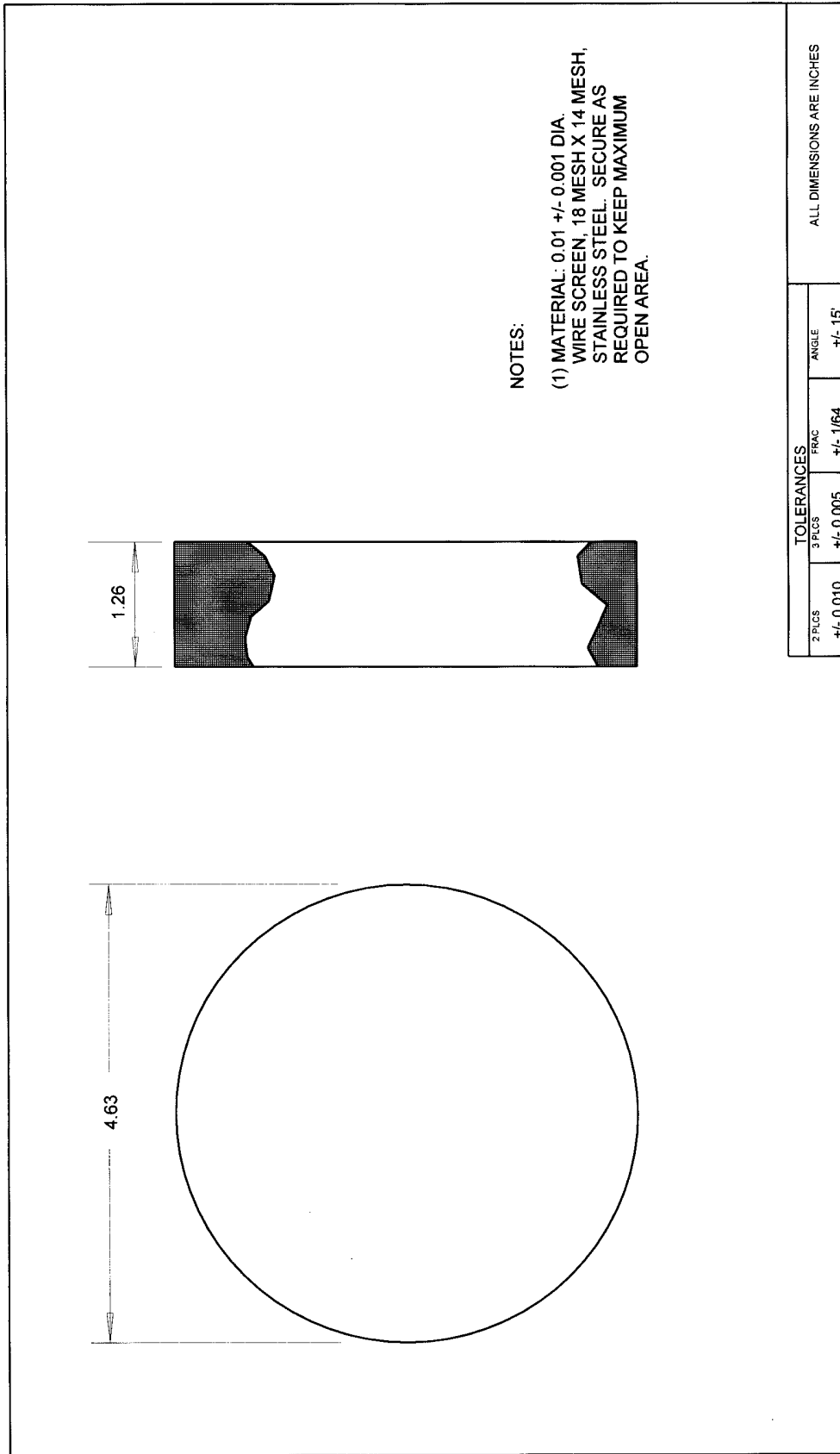

FIGURE L-8. 10-MICRON SCREEN



NOTES:

- (1) MATERIAL: 0.01 +/- 0.001 DIA. WIRE SCREEN, 18 MESH X 14 MESH, STAINLESS STEEL. SECURE AS REQUIRED TO KEEP MAXIMUM OPEN AREA.

TOLERANCES		ALL DIMENSIONS ARE INCHES	
2 PLCS	3 PLCS	FRAC	ANGLE
+/- 0.010	+/- 0.005	+/- 1/64	+/- 15'

FIGURE L-9. 10-MICRON SPACER

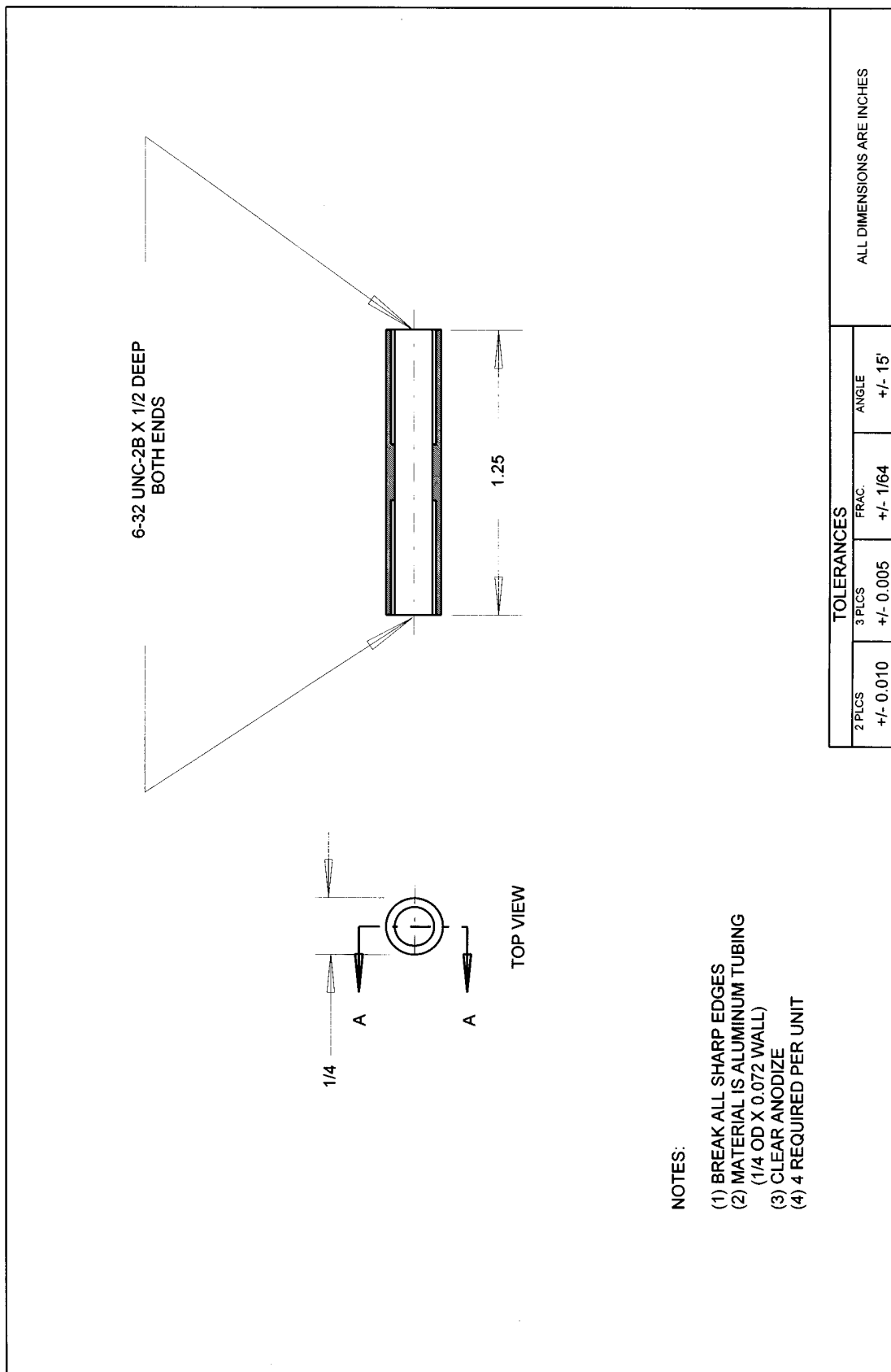

FIGURE L-10. 10-MICRON RAIN DEFLECTOR

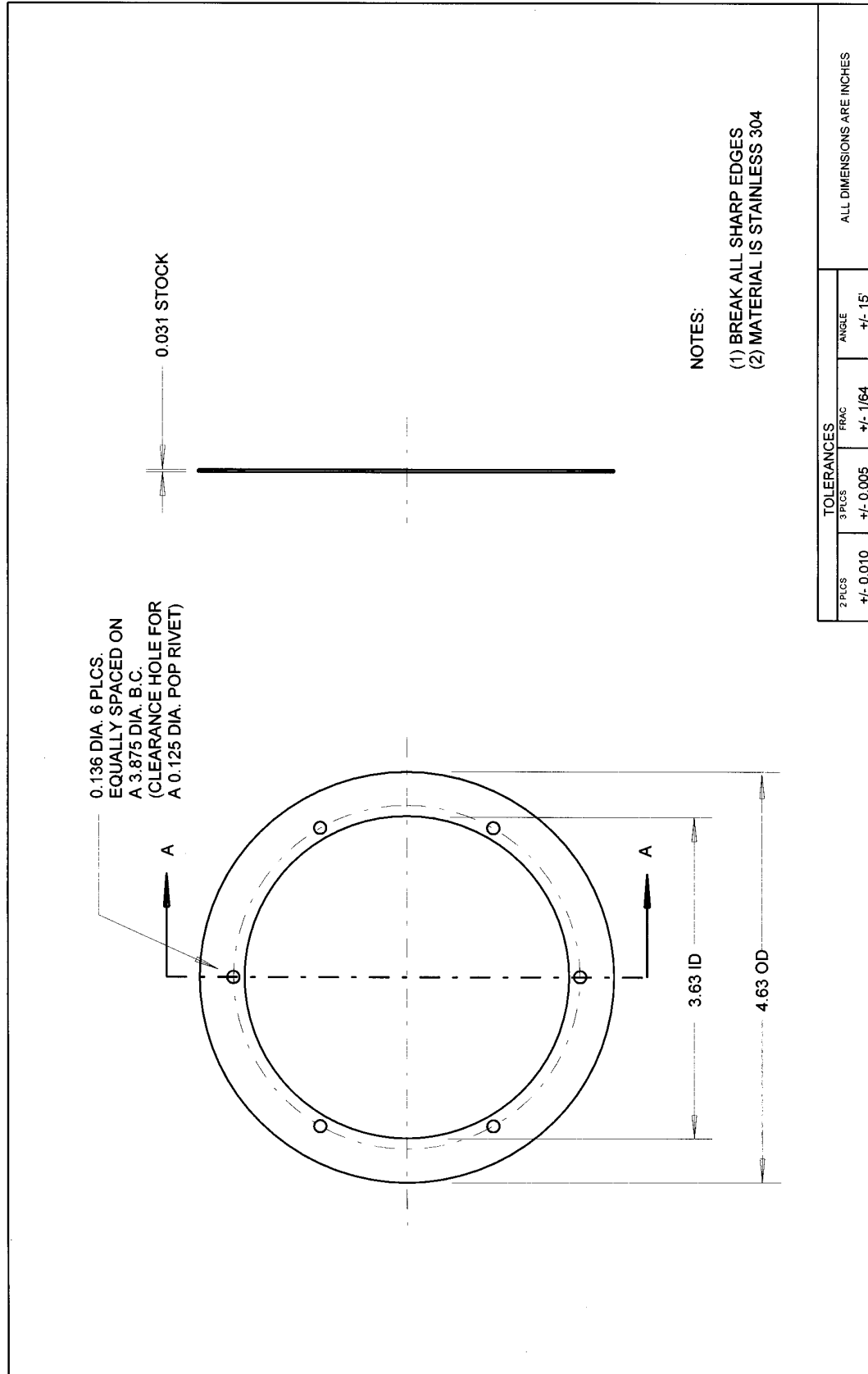

FIGURE L-11. 10-MICRON INLET, LOWER

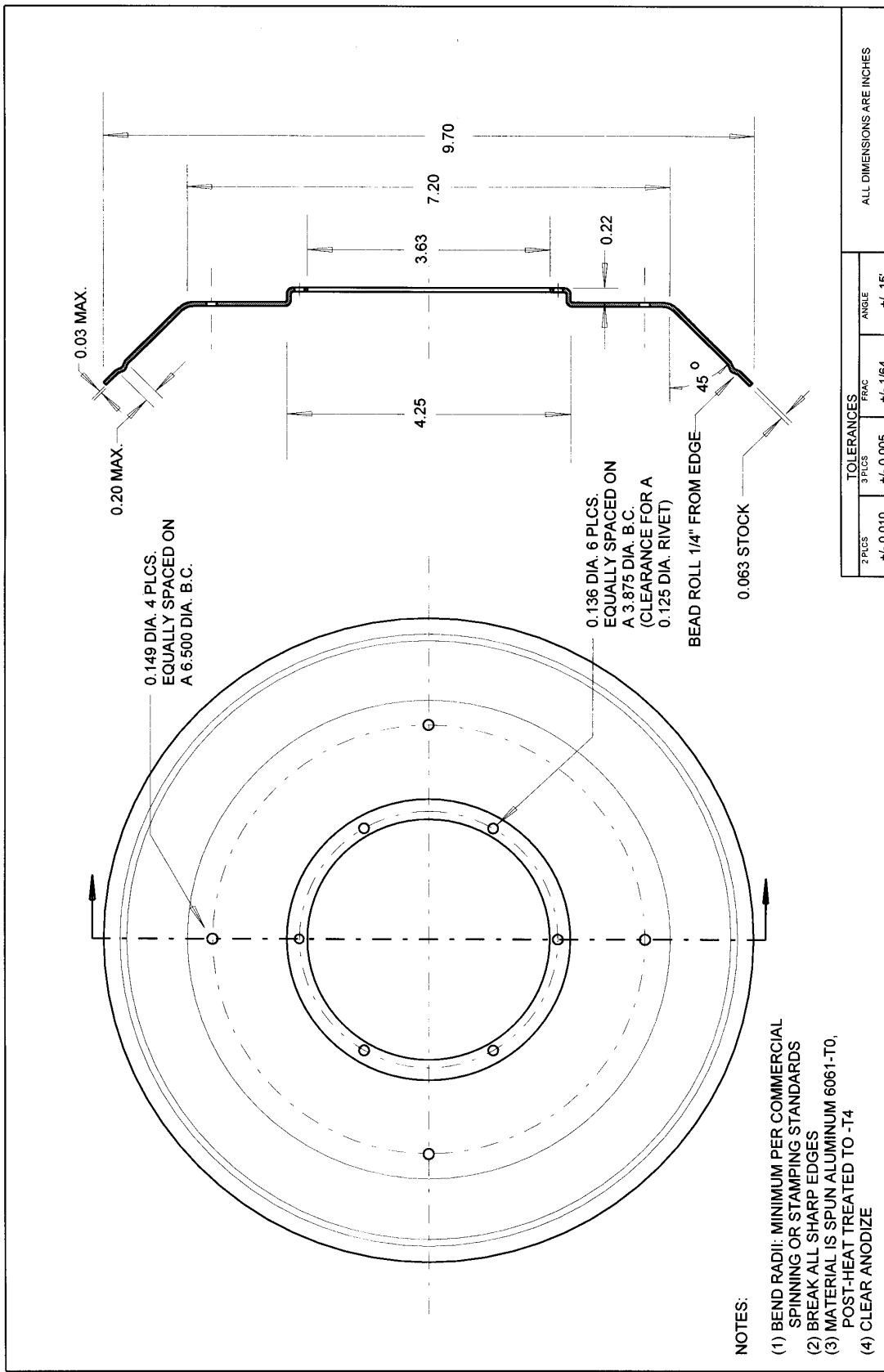

FIGURE L-12. 10-MICRON NOZZLE ENTRY SECTION

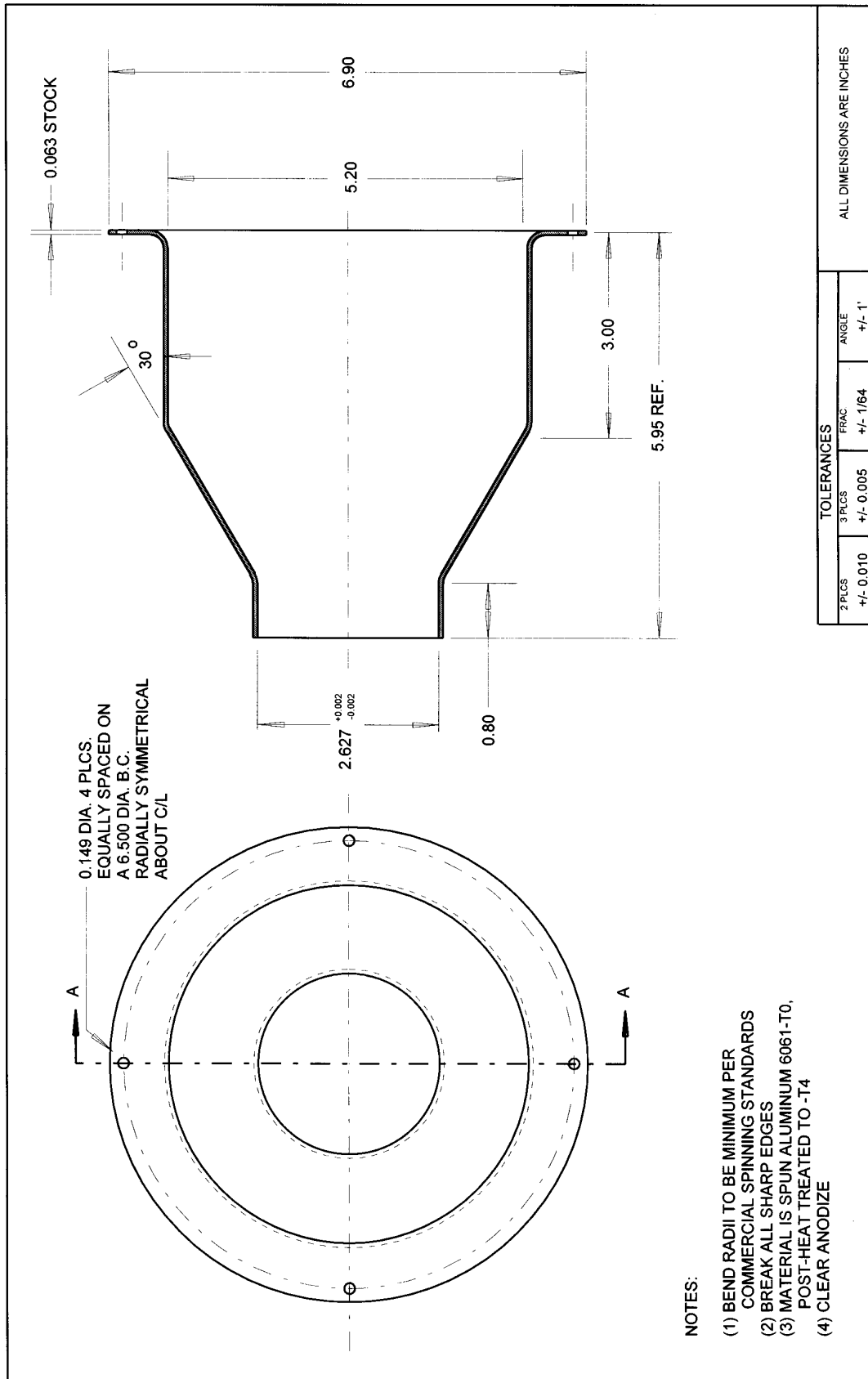

FIGURE L-13. 10-MICRON IMPACTOR NOZZLE

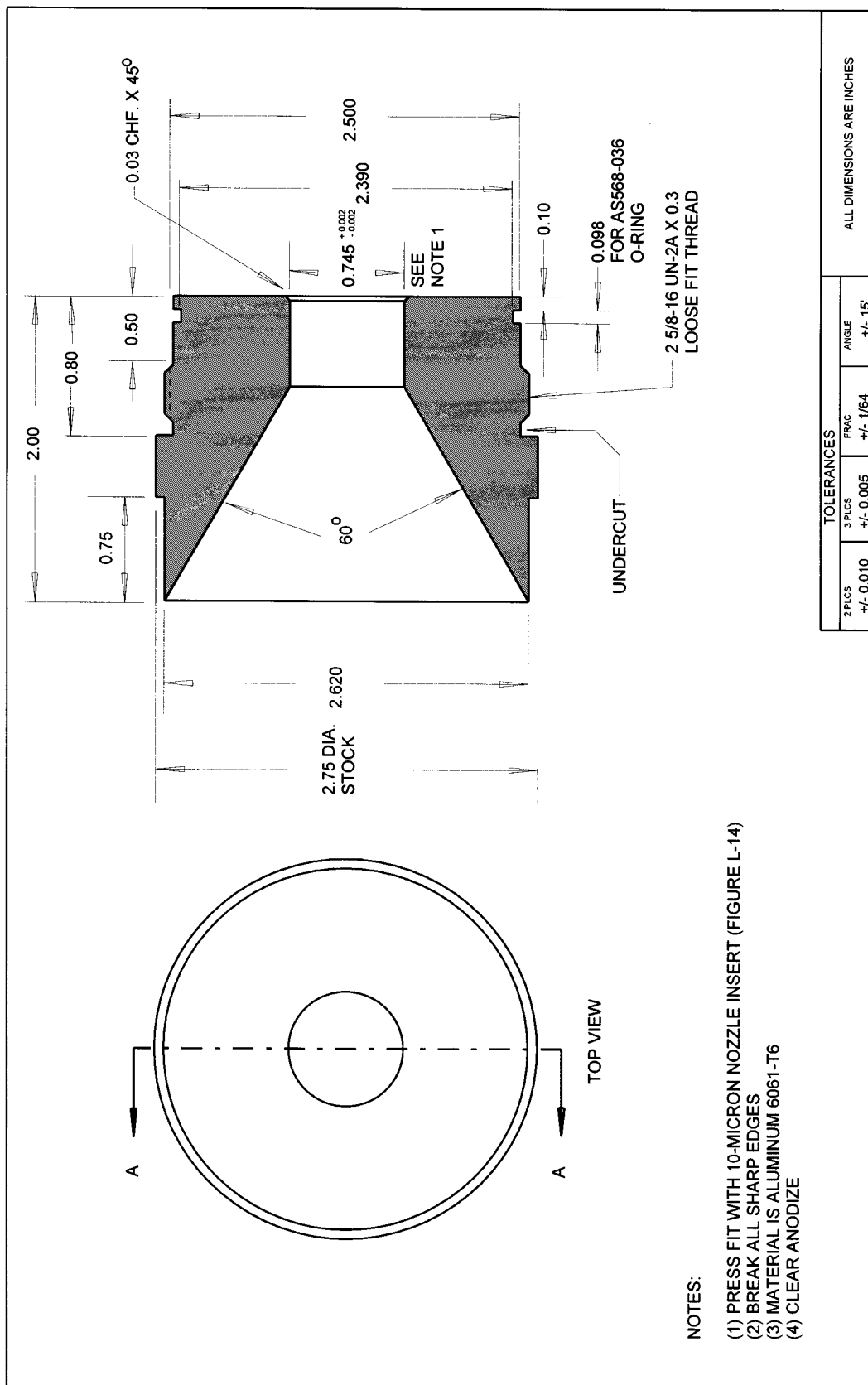
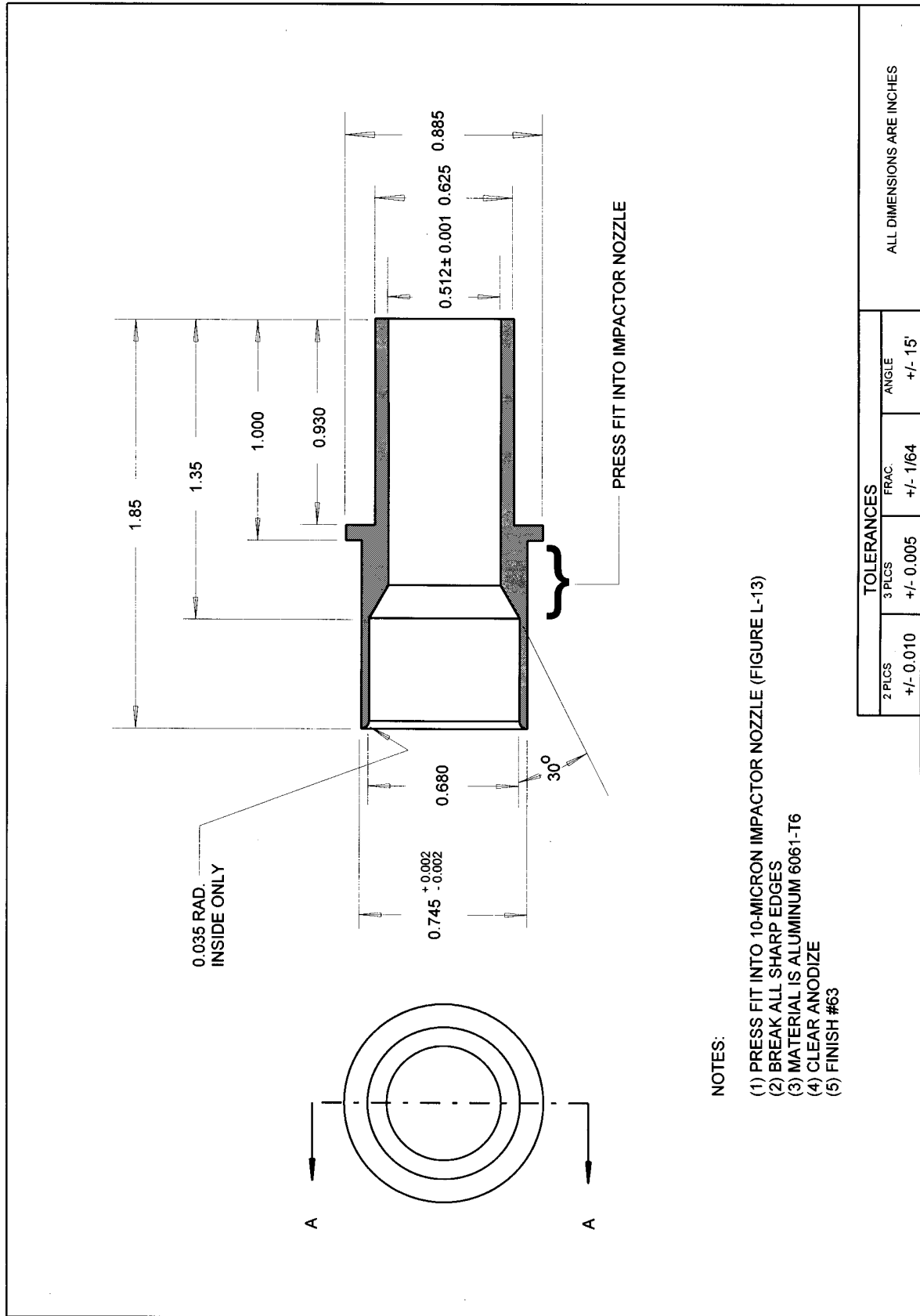

FIGURE L-14. 10-MICRON NOZZLE INSERT



NOTES:

- (1) PRESS FIT INTO 10-MICRON IMPACTOR NOZZLE (FIGURE L-13)
- (2) BREAK ALL SHARP EDGES
- (3) MATERIAL IS ALUMINUM 6061-T6
- (4) CLEAR ANODIZE
- (5) FINISH #63

TOLERANCES		
2 PLCS	3 PLCS	ANGLE
+/- 0.010	+/- 0.005	+/- 15'
	FRAC.	
	+/- 1/64	

ALL DIMENSIONS ARE INCHES

FIGURE L-15. 10-MICRON OUTER TUBE

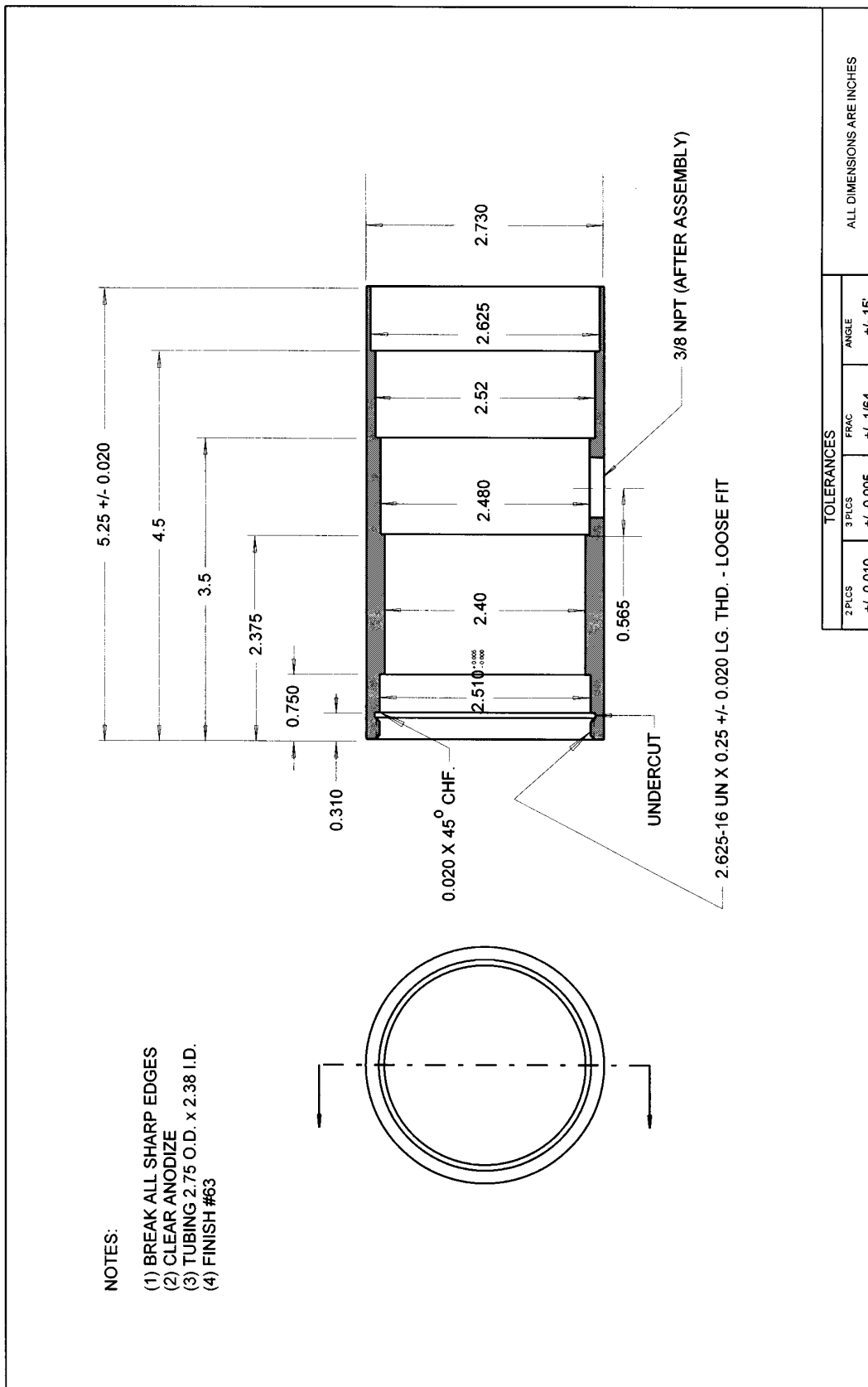

FIGURE L-16. 10-MICRON RECEIVER TUBE

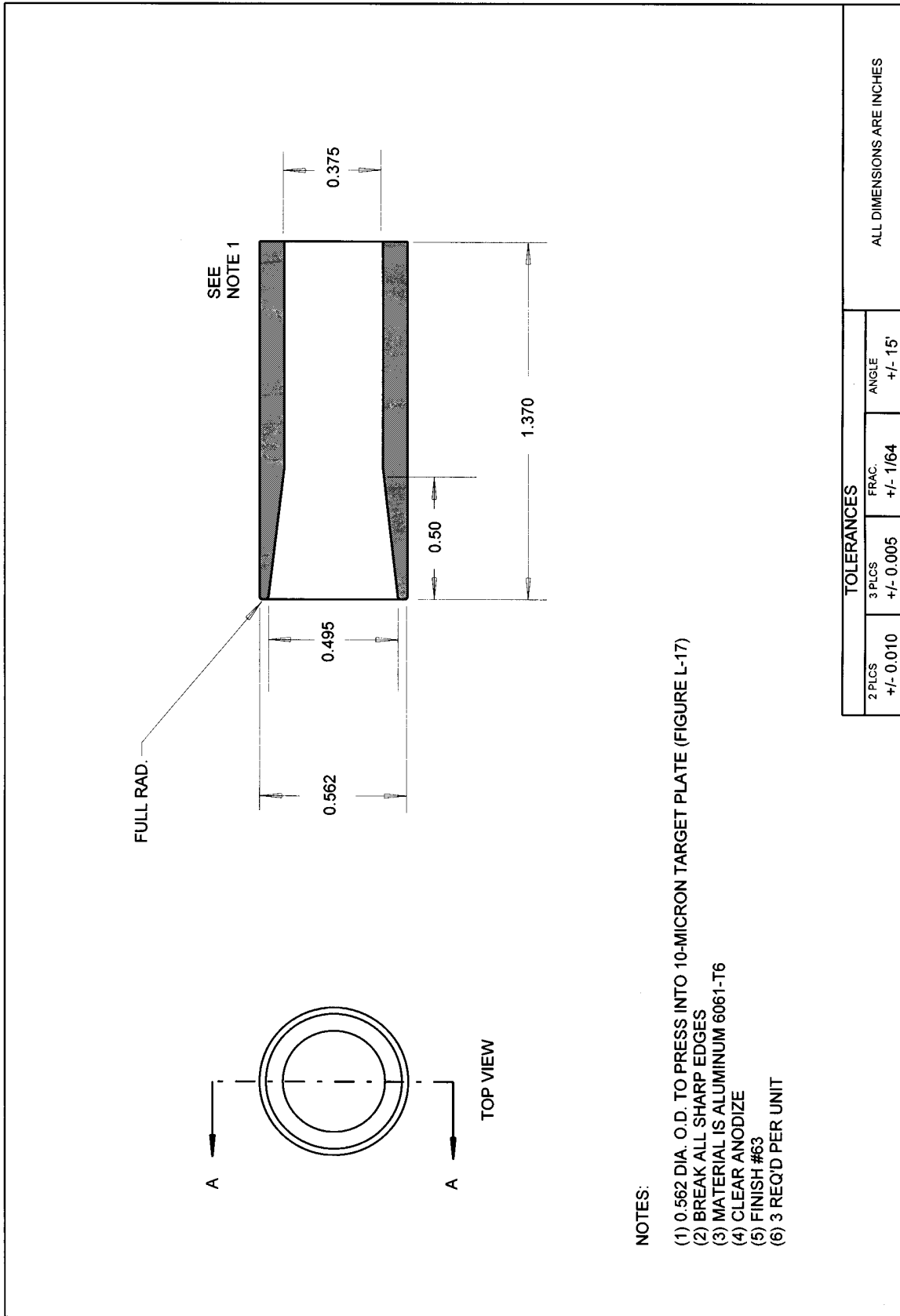

FIGURE L-17. 10-MICRON TARGET PLATE

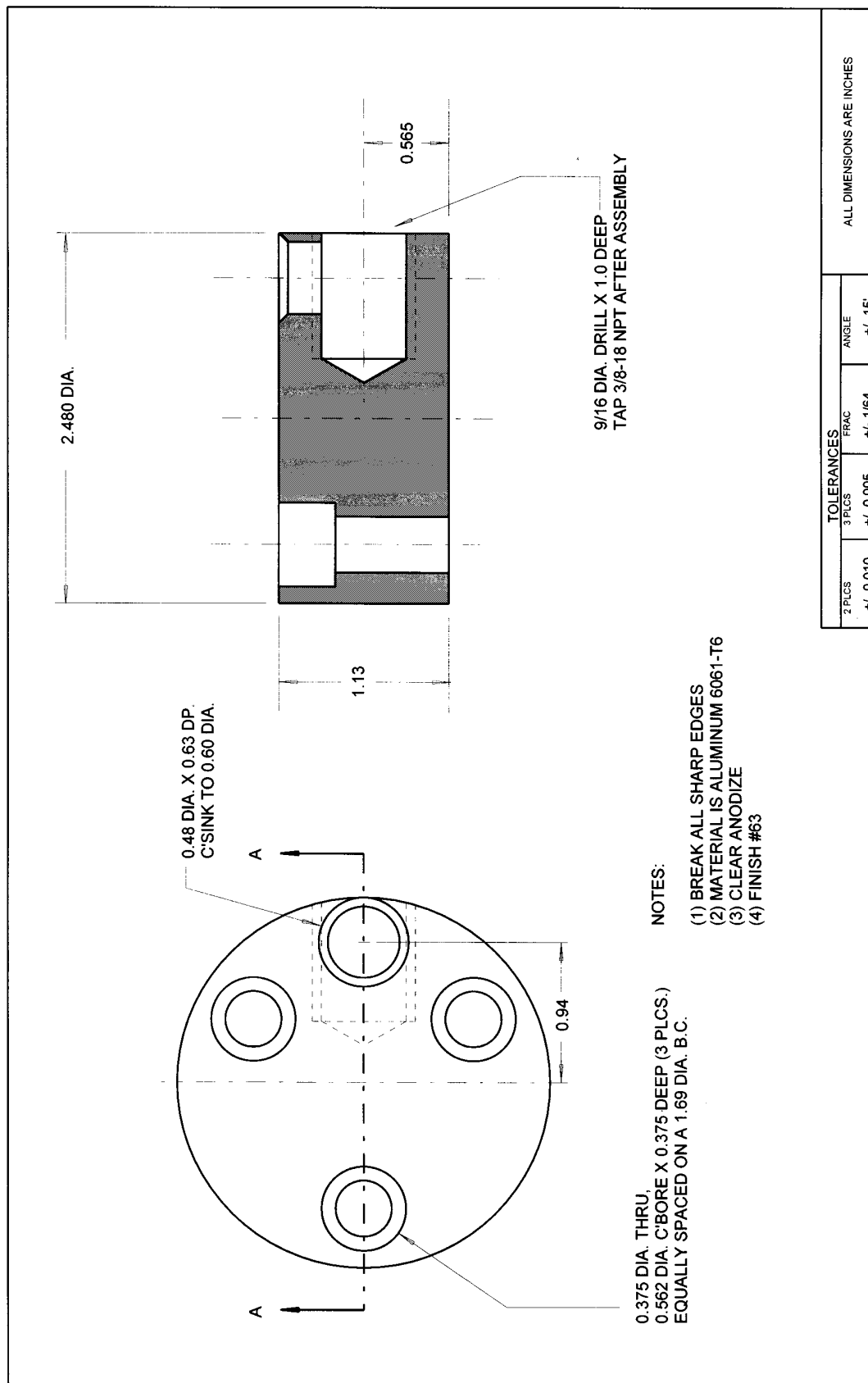

FIGURE L-18. 10-MICRON EXIT ADAPTOR

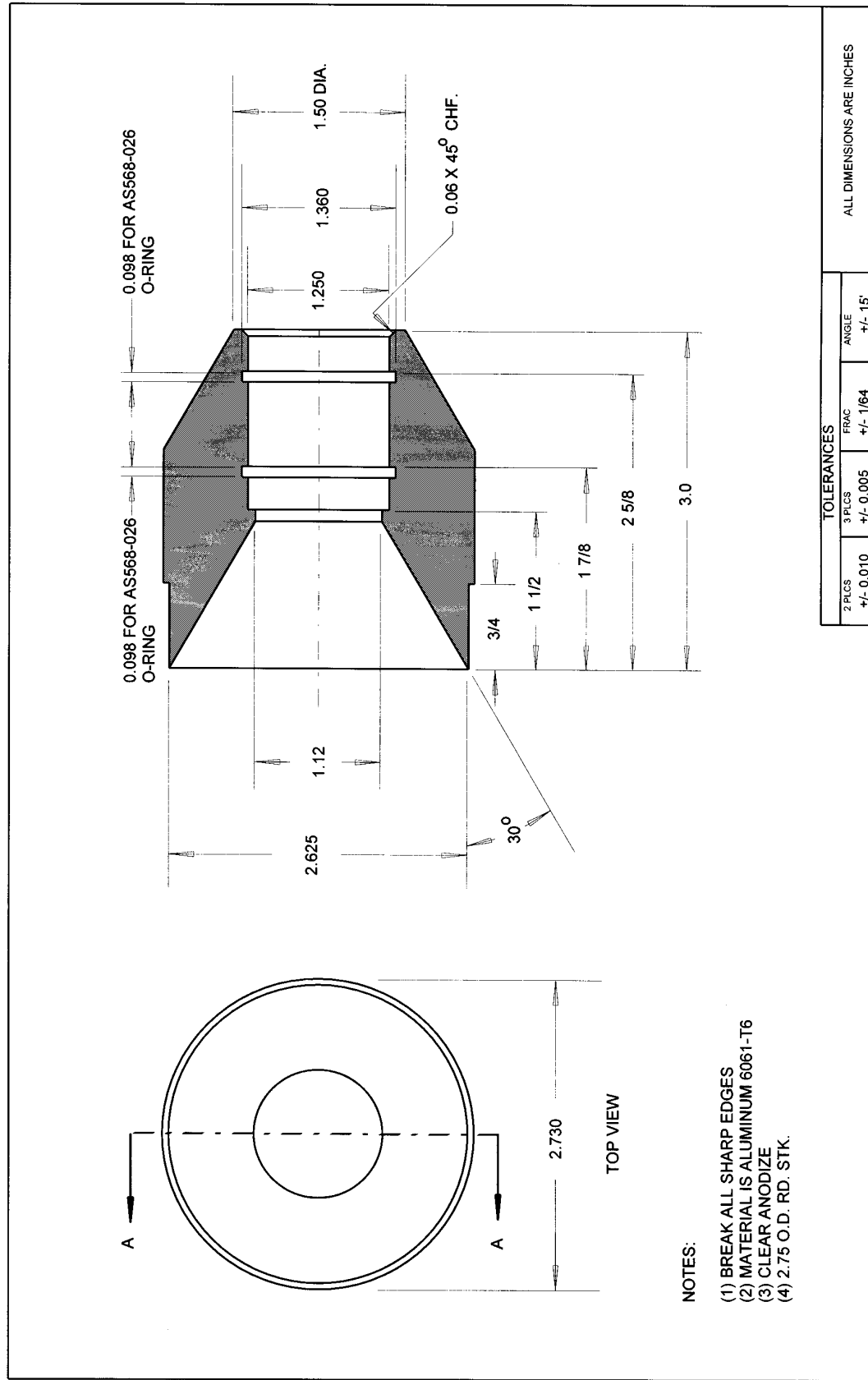

FIGURE L-19. 10-MICRON DOWN TUBE

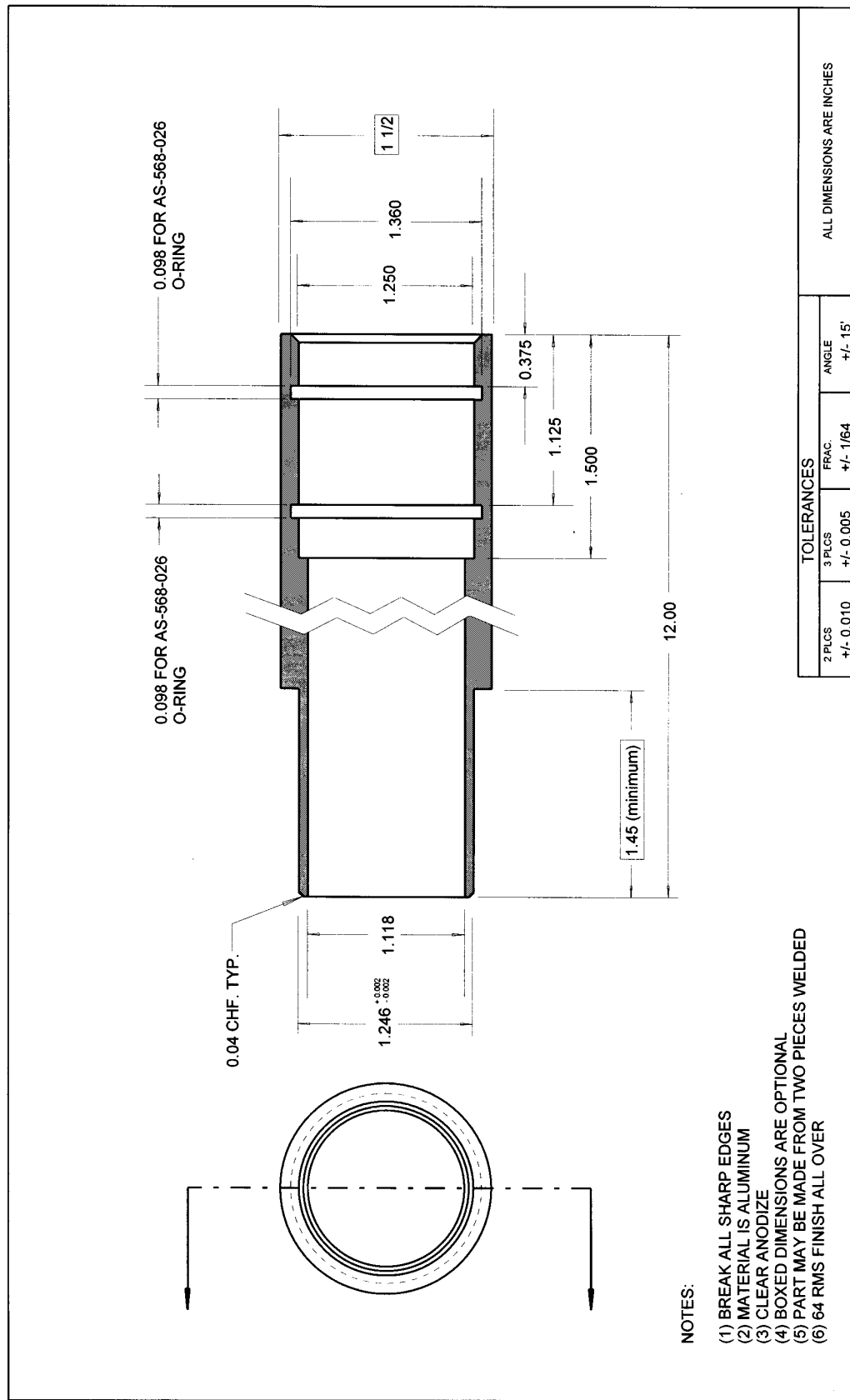

FIGURE L-20. 2.5-MICRON IMPACTOR ASSEMBLY

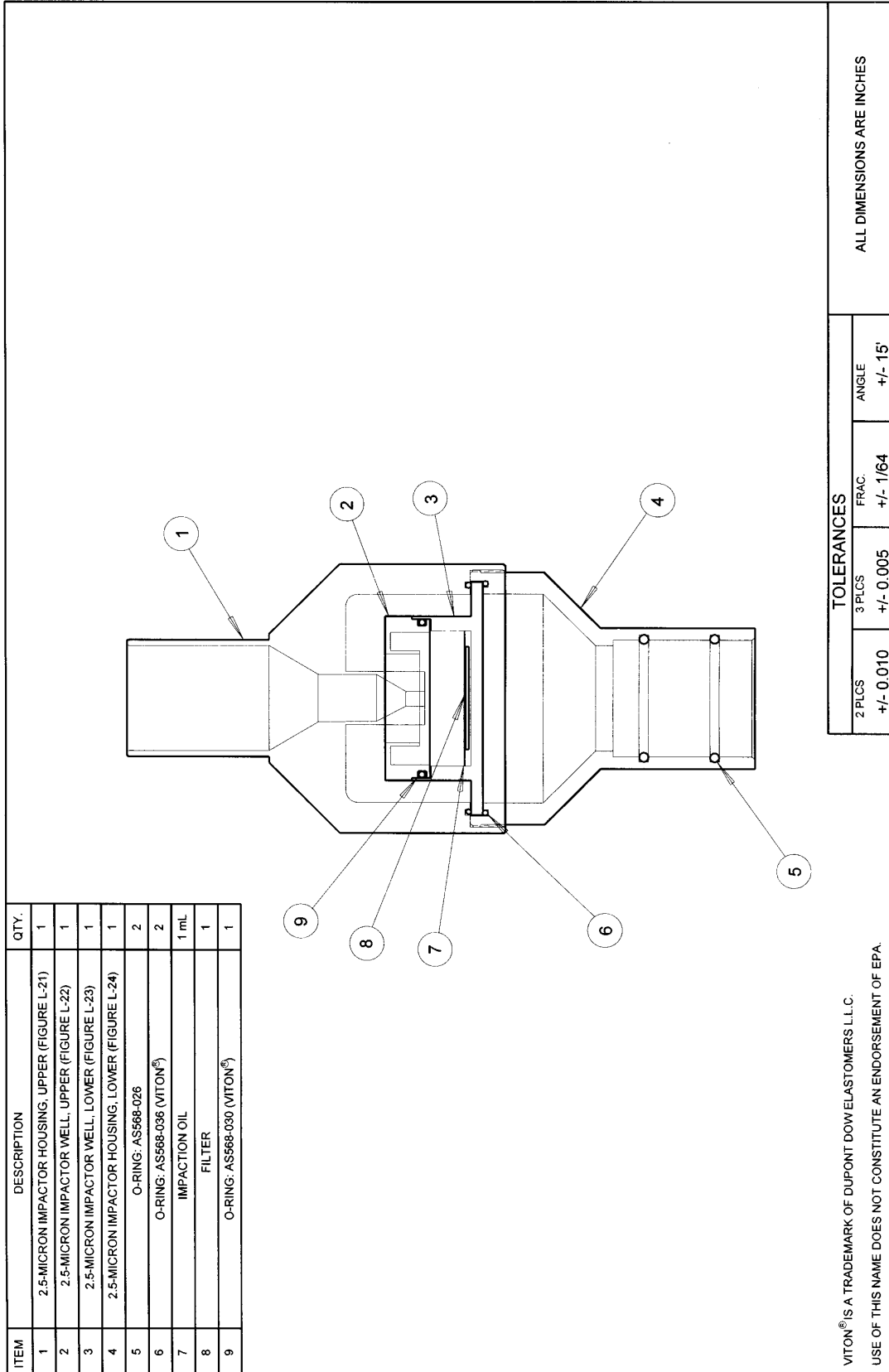

FIGURE L-21. 2.5-MICRON IMPACTOR HOUSING, UPPER

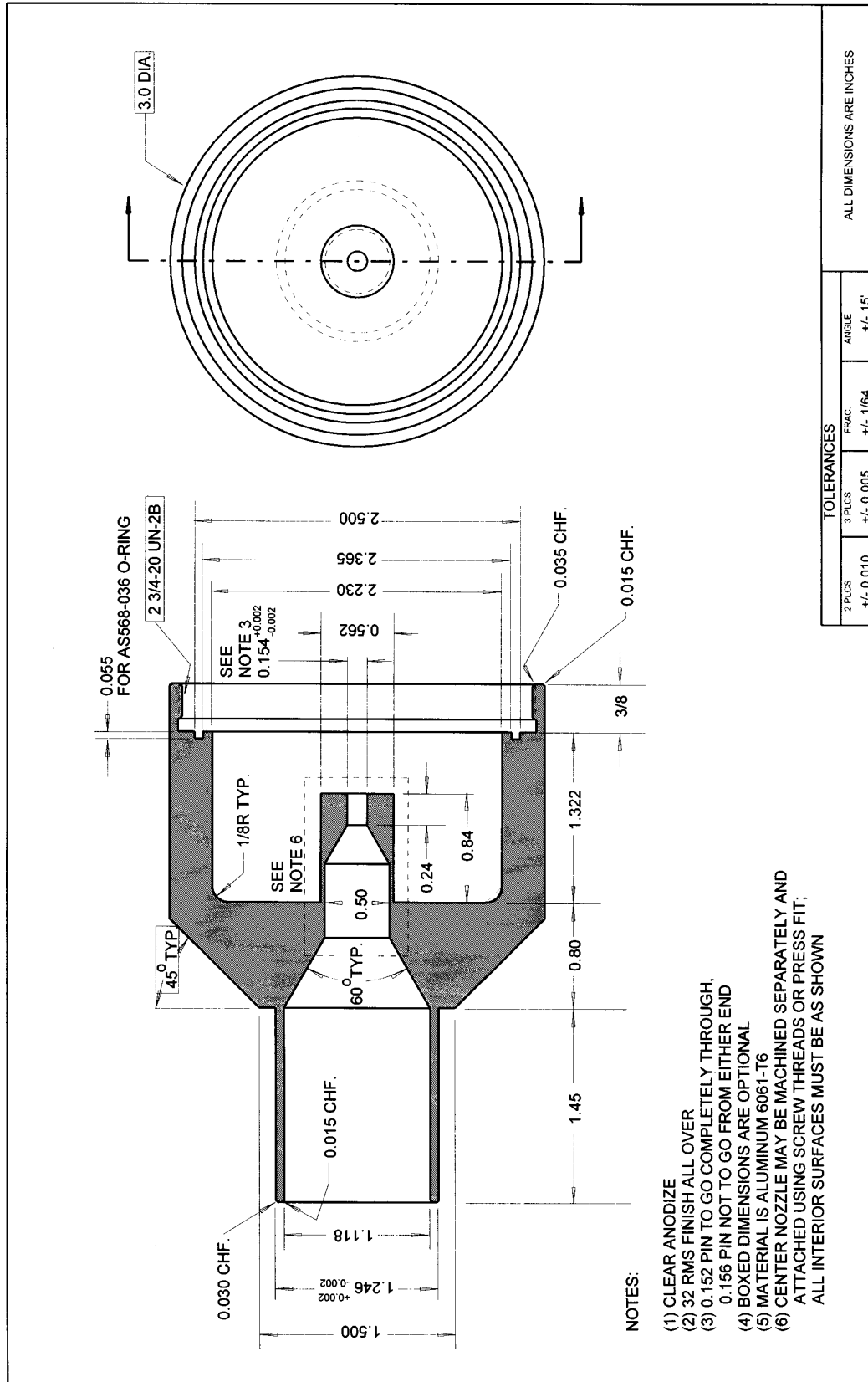

FIGURE L-22. 2.5-MICRON IMPACTOR WELL, UPPER SECTION

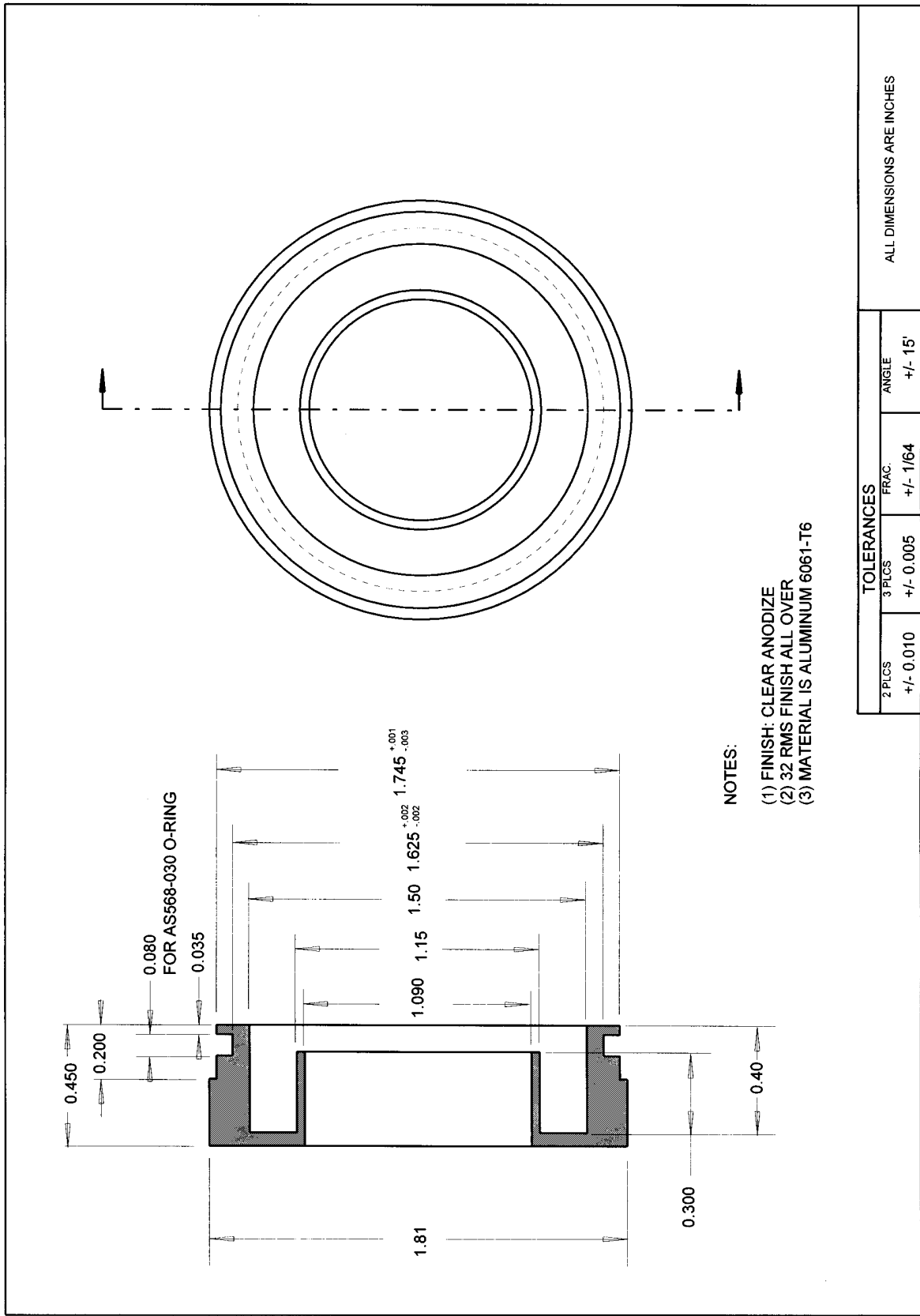

FIGURE L-23. 2.5-MICRON IMPACTOR WELL, LOWER SECTION

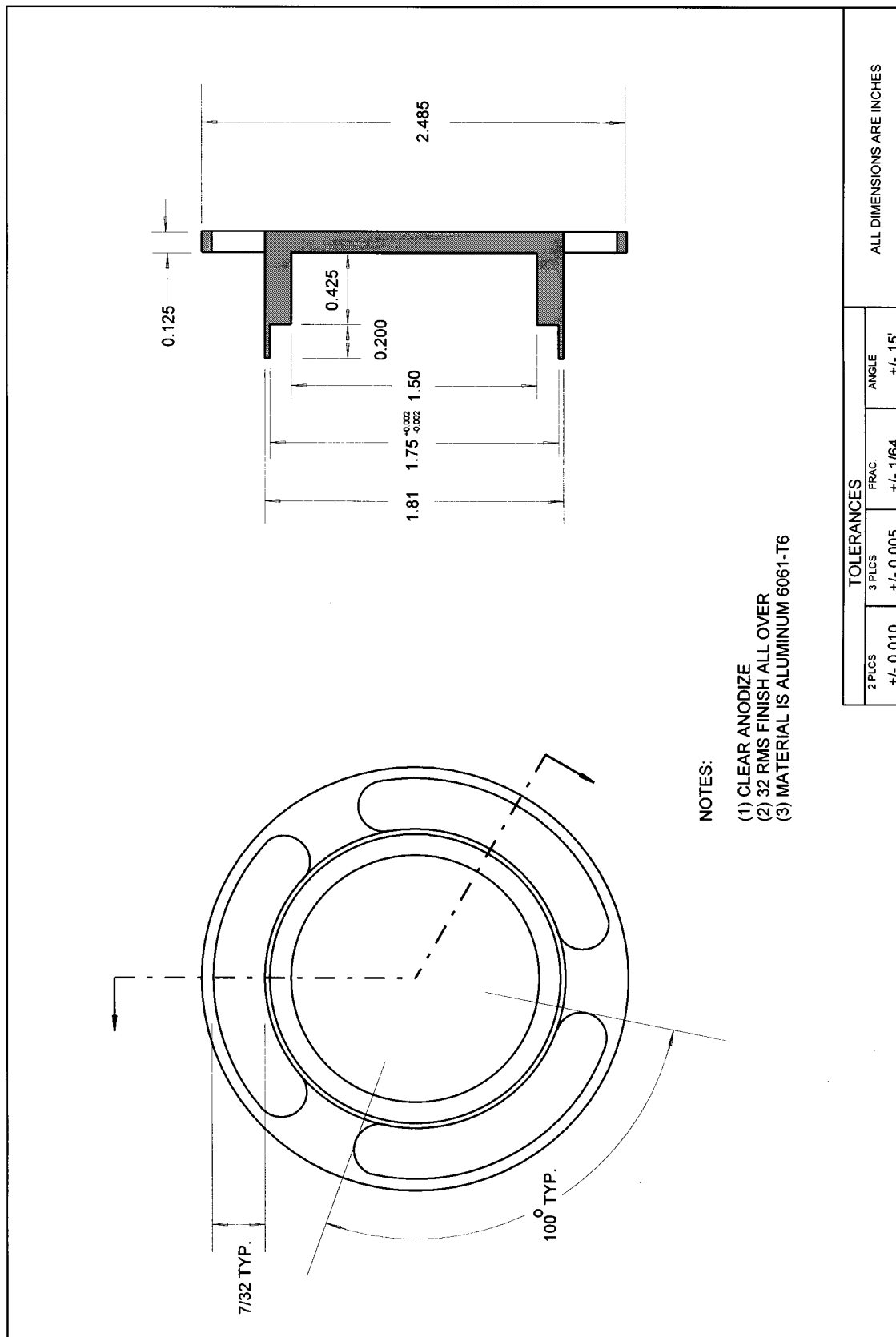

FIGURE L-24. 2.5-MICRON IMPACTOR HOUSING, LOWER

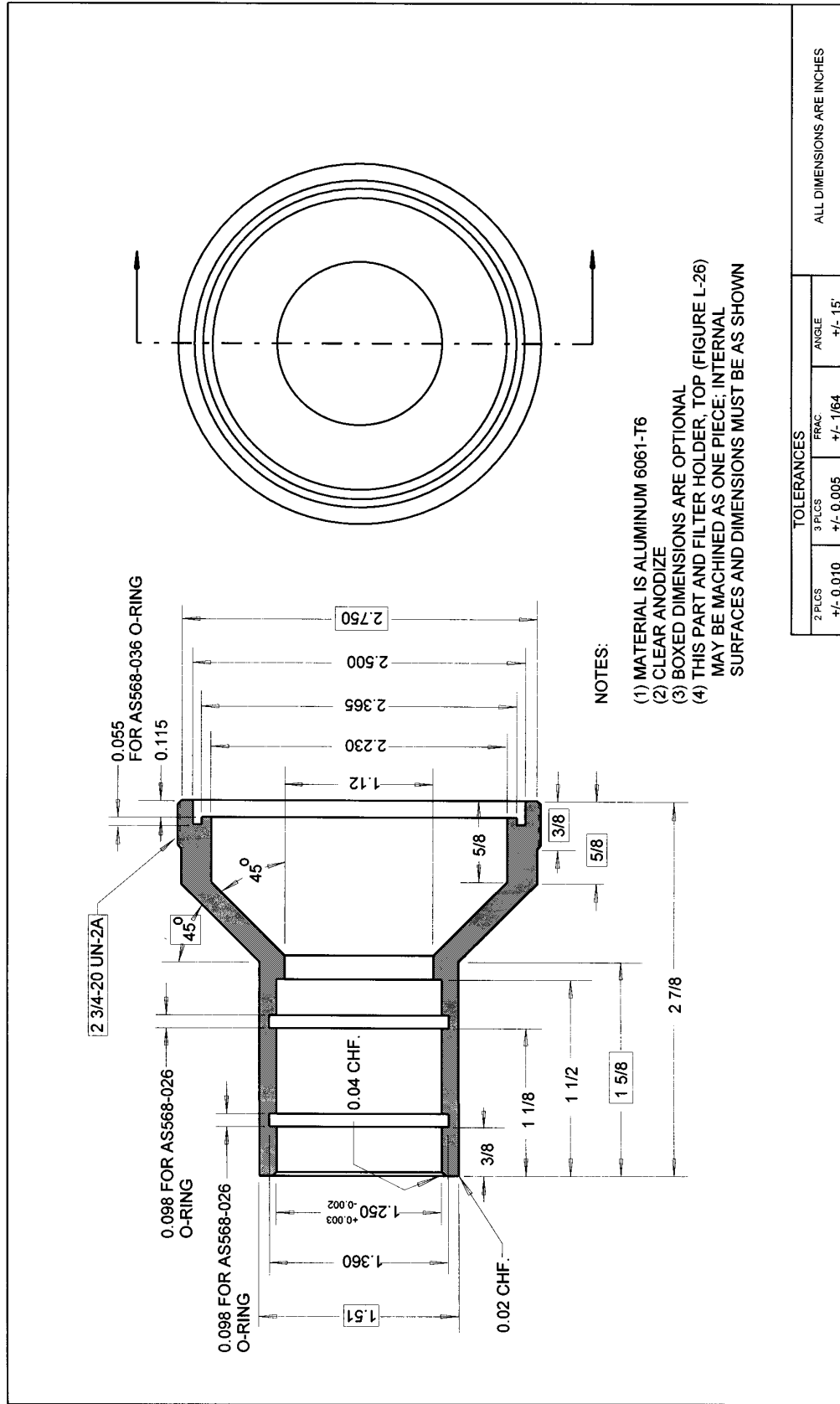
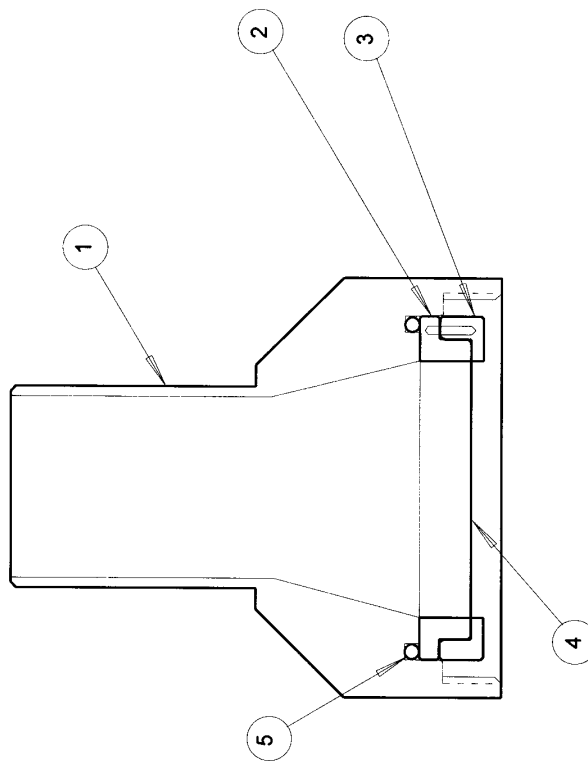

FIGURE L-25. FILTER HOLDER, ASSEMBLY

ITEM	DESCRIPTION	QTY.
1	FILTER HOLDER, TOP (FIGURE L-26)	1
2	FILTER CASSETTE, UPPER (FIGURE L-27)	1
3	FILTER CASSETTE, LOWER (FIGURE L-28)	1
4	FILTER SCREEN (FIGURE L-28) AND FILTER	1
5	O-RING: AS568-135	1



TOLERANCES			
2 PLCS	3 PLCS	ANGLE	
+/- 0.010	+/- 0.005	+/- 1/64	+/- .15'

ALL DIMENSIONS ARE INCHES

FIGURE L-26. FILTER HOLDER, TOP

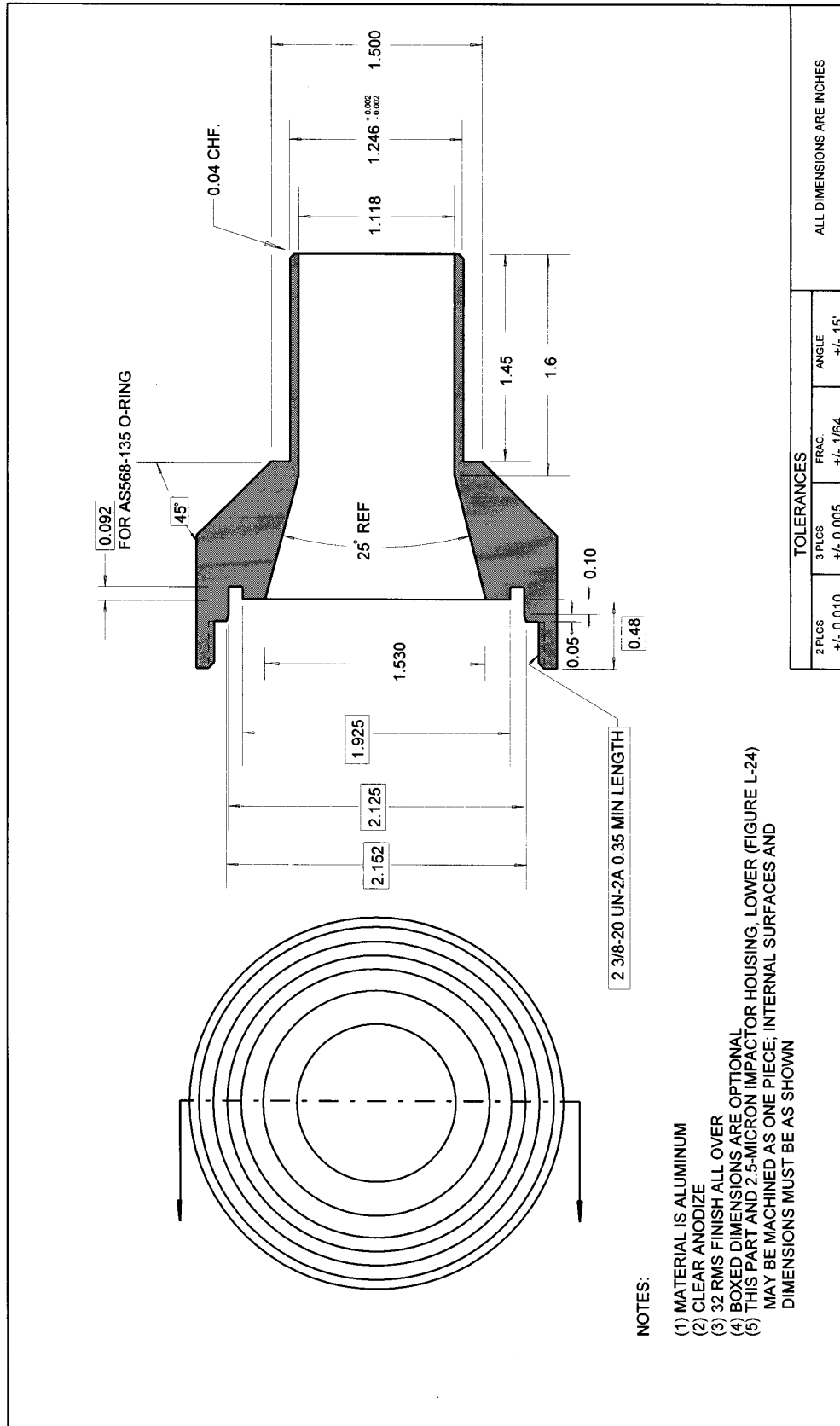

FIGURE L-27. FILTER CASSETTE, UPPER SECTION

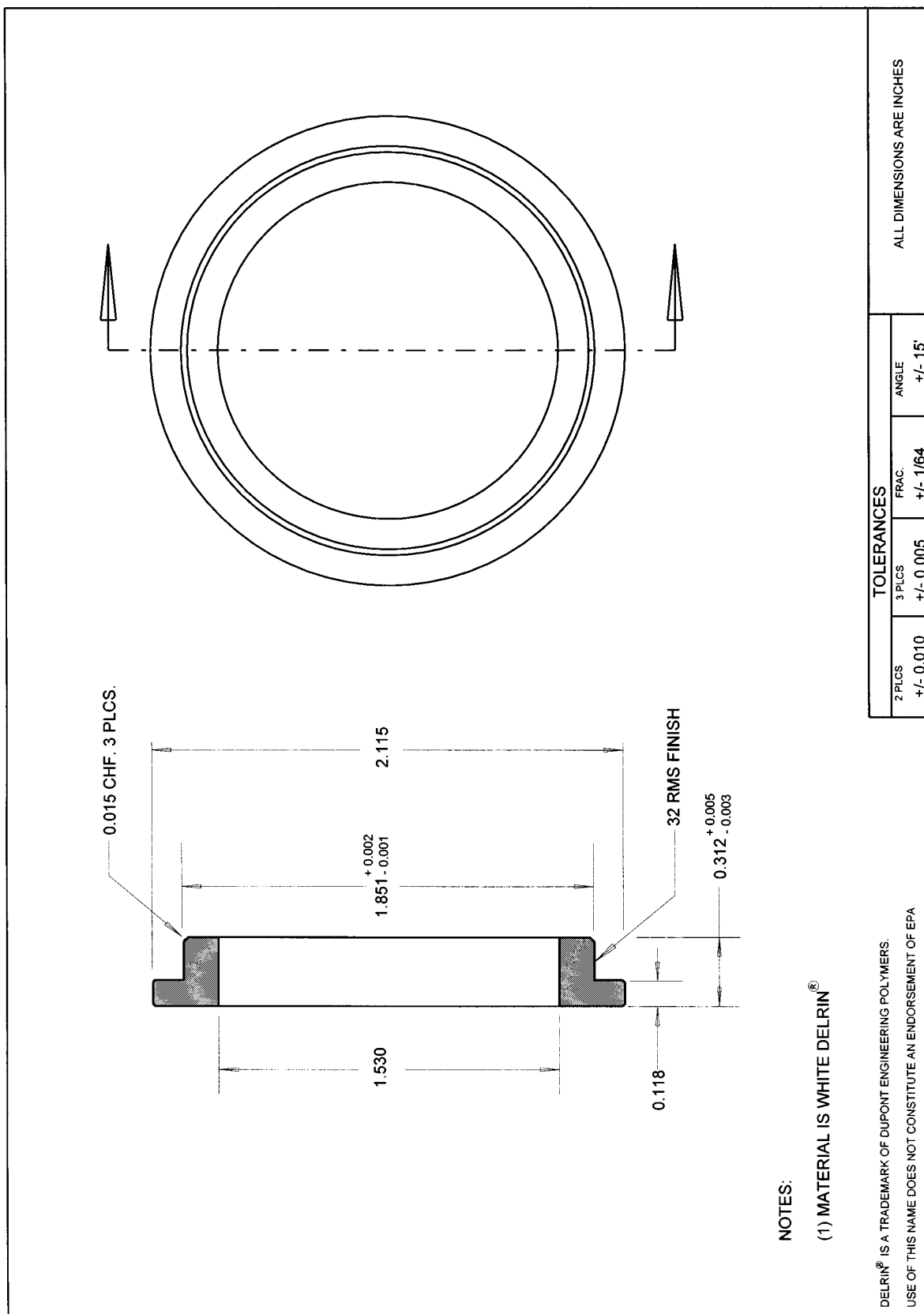

FIGURE L-28. FILTER SCREEN

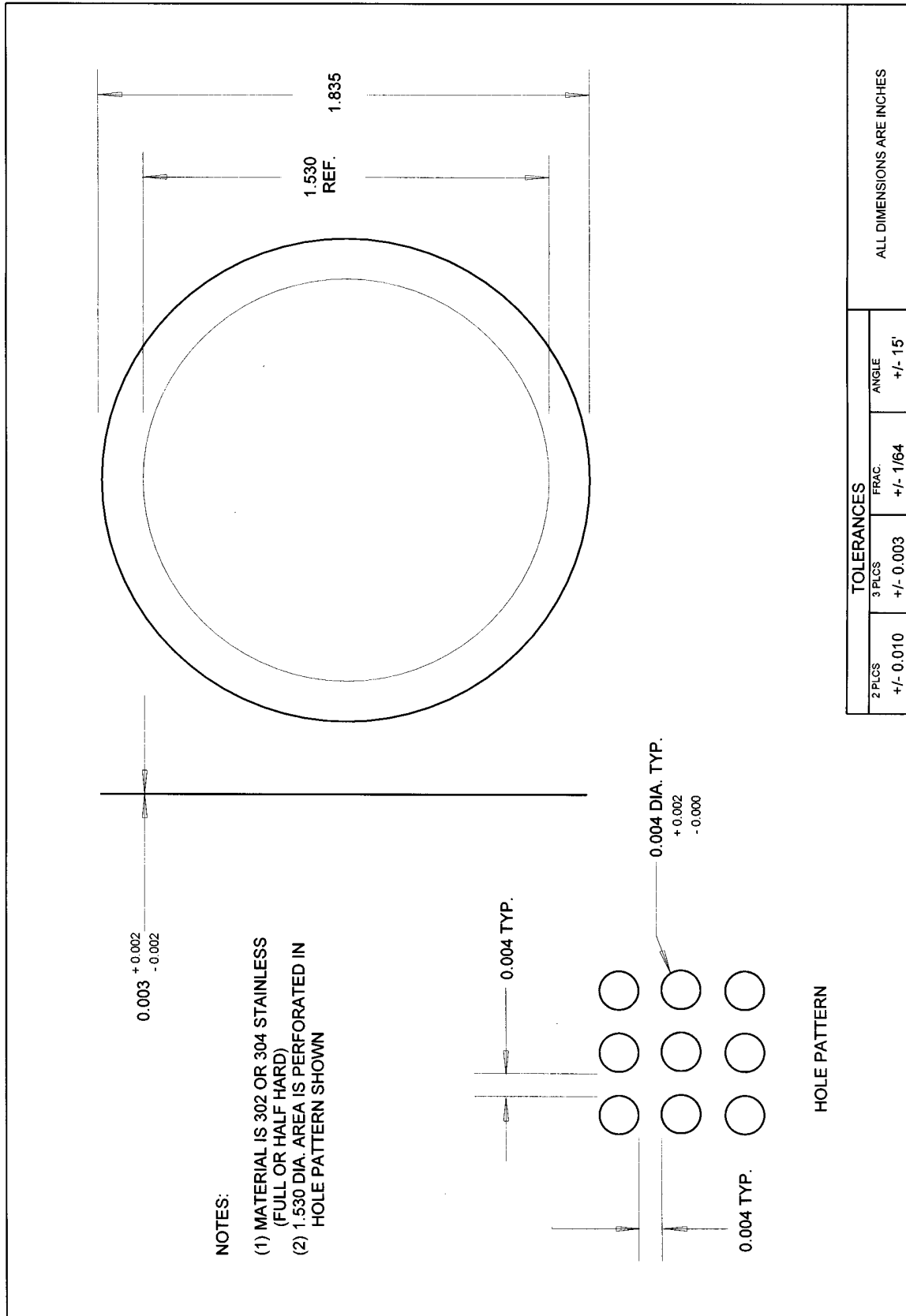

FIGURE L-29. FILTER CASSETTE, LOWER SECTION

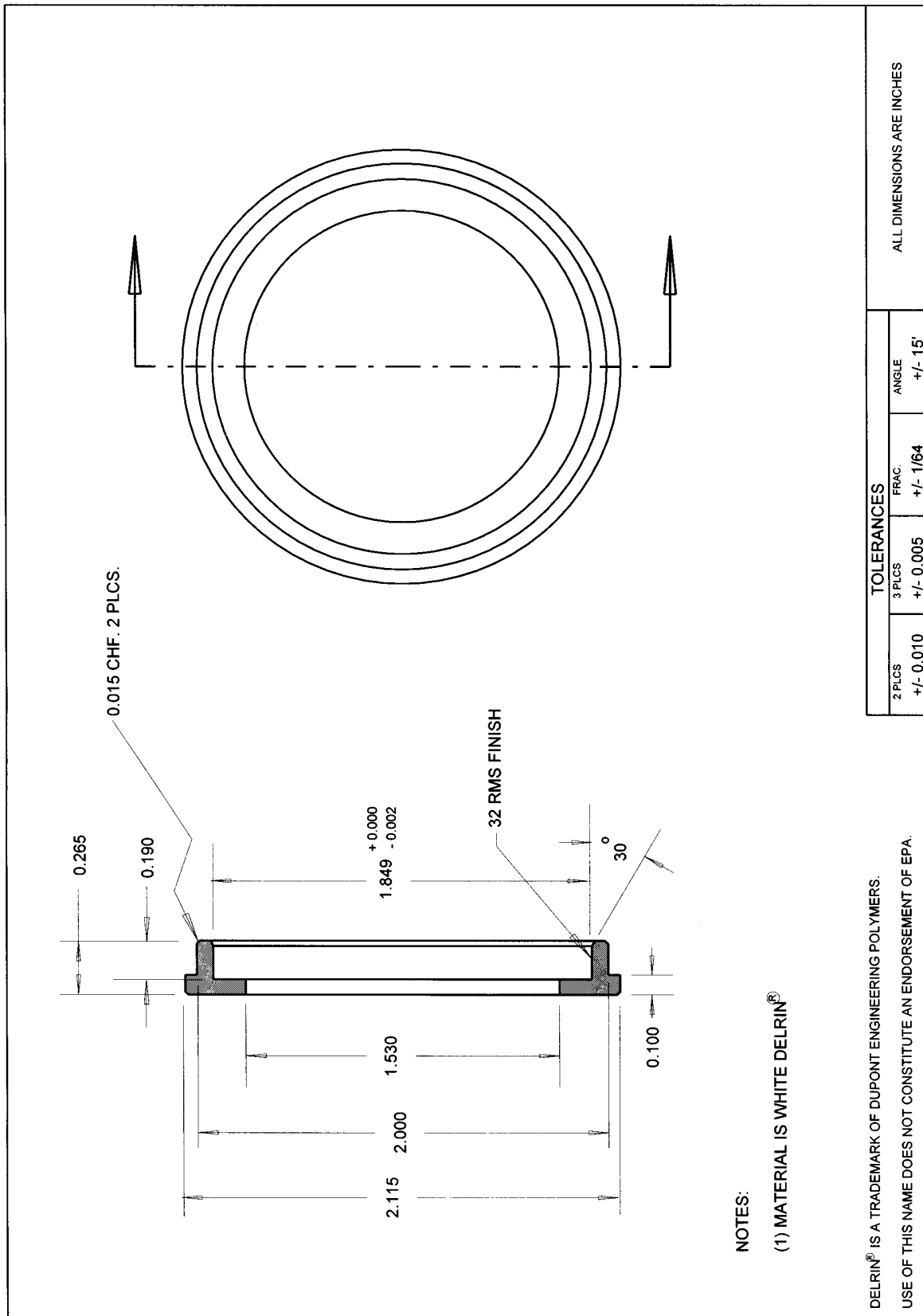
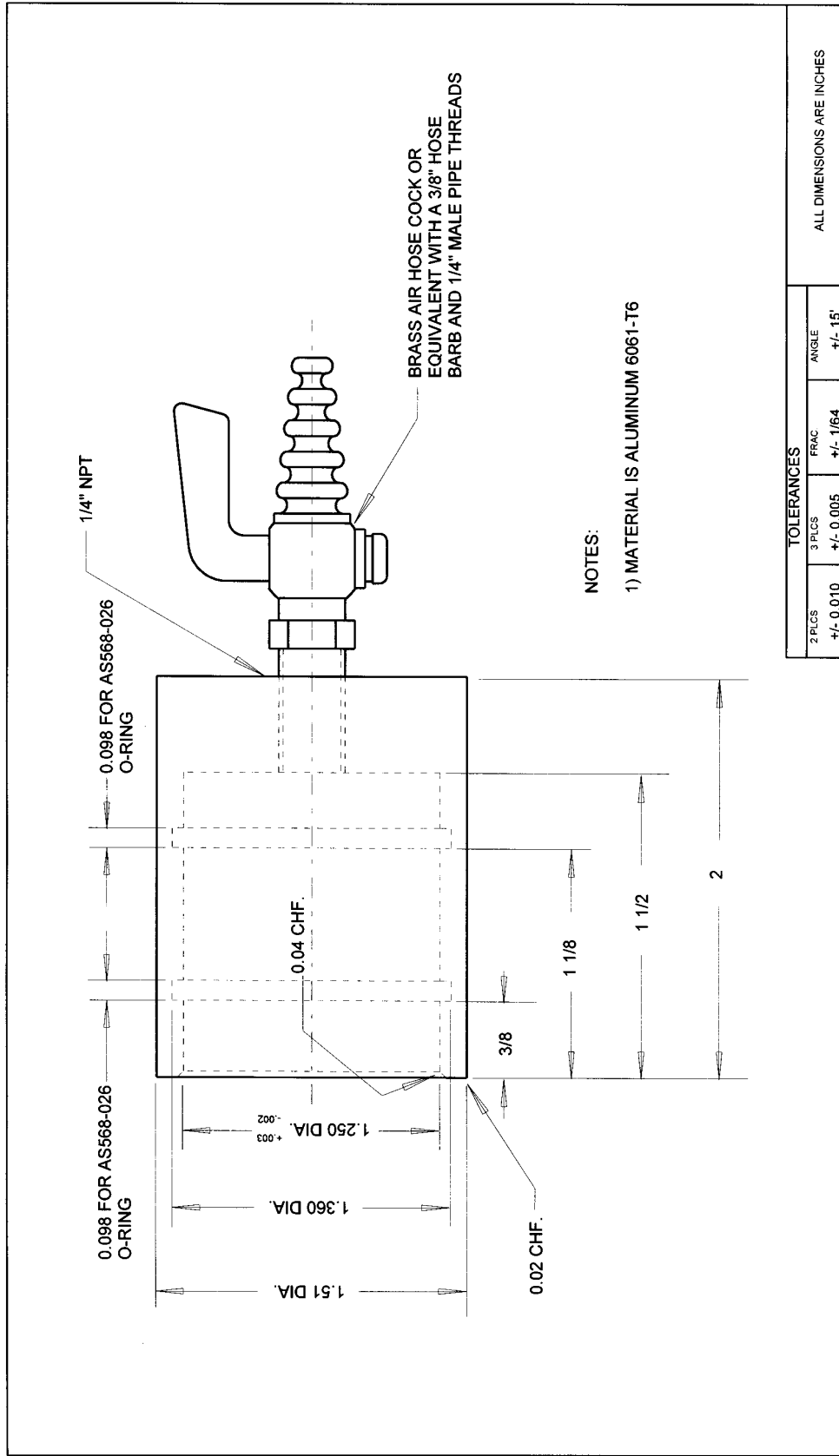

FIGURE L-30. FLOW RATE MEASUREMENT ADAPTER



7. Appendix M is added to read as follows:

Appendix M to Part 50—Reference Method for the Determination of Particulate Matter as PM₁₀ in the Atmosphere

1.0 Applicability.

1.1 This method provides for the measurement of the mass concentration of particulate matter with an aerodynamic diameter less than or equal to a nominal 10 micrometers (PM₁₀) in ambient air over a 24-hour period for purposes of determining attainment and maintenance of the primary and secondary national ambient air quality standards for particulate matter specified in § 50.6 of this chapter. The measurement process is nondestructive, and the PM₁₀ sample can be subjected to subsequent physical or chemical analyses. Quality assurance procedures and guidance are provided in part 58, Appendices A and B of this chapter and in references 1 and 2 of section 12.0 of this appendix.

2.0 Principle.

2.1 An air sampler draws ambient air at a constant flow rate into a specially shaped inlet where the suspended particulate matter is inertially separated into one or more size fractions within the PM₁₀ size range. Each size fraction in the PM₁₀ size range is then collected on a separate filter over the specified sampling period. The particle size discrimination characteristics (sampling effectiveness and 50 percent cutpoint) of the sampler inlet are prescribed as performance specifications in part 53 of this chapter.

2.2 Each filter is weighed (after moisture equilibration) before and after use to determine the net weight (mass) gain due to collected PM₁₀. The total volume of air sampled, measured at the actual ambient temperature and pressure, is determined from the measured flow rate and the sampling time. The mass concentration of PM₁₀ in the ambient air is computed as the total mass of collected particles in the PM₁₀ size range divided by the volume of air sampled, and is expressed in micrograms per actual cubic meter (µg/m³).

2.3 A method based on this principle will be considered a reference method only if the associated sampler meets the requirements specified in this appendix and the requirements in part 53 of this chapter, and the method has been designated as a reference method in accordance with part 53 of this chapter.

3.0 Range.

3.1 The lower limit of the mass concentration range is determined by the repeatability of filter tare weights, assuming the nominal air sample volume for the sampler. For samplers having an automatic filter-changing mechanism, there may be no upper limit. For samplers that do not have an automatic filter-changing mechanism, the upper limit is determined by the filter mass loading beyond which the sampler no longer maintains the operating flow rate within specified limits due to increased pressure drop across the loaded filter. This upper limit cannot be specified precisely because it is a complex function of the ambient particle size distribution and type, humidity, filter type, and perhaps other factors. Nevertheless, all samplers should be capable of measuring 24-hour PM₁₀ mass concentrations of at least 300 µg/m³ while maintaining the operating flow rate within the specified limits.

4.0 Precision.

4.1 The precision of PM₁₀ samplers must be 5 µg/m³ for PM₁₀ concentrations below 80 µg/m³ and 7 percent for PM₁₀ concentrations above 80 µg/m³, as required by part 53 of this chapter, which

prescribes a test procedure that determines the variation in the PM₁₀ concentration measurements of identical samplers under typical sampling conditions. Continual assessment of precision via collocated samplers is required by part 58 of this chapter for PM₁₀ samplers used in certain monitoring networks.

5.0 Accuracy.

5.1 Because the size of the particles making up ambient particulate matter varies over a wide range and the concentration of particles varies with particle size, it is difficult to define the absolute accuracy of PM₁₀ samplers. Part 53 of this chapter provides a specification for the sampling effectiveness of PM₁₀ samplers. This specification requires that the expected mass concentration calculated for a candidate PM₁₀ sampler, when sampling a specified particle size distribution, be within ±10 percent of that calculated for an ideal sampler whose sampling effectiveness is explicitly specified. Also, the particle size for 50 percent sampling effectiveness is required to be 10±0.5 micrometers. Other specifications related to accuracy apply to flow measurement and calibration, filter media, analytical (weighing) procedures, and artifact. The flow rate accuracy of PM₁₀ samplers used in certain monitoring networks is required by part 58 of this chapter to be assessed periodically via flow rate audits.

6.0 Potential Sources of Error.

6.1 *Volatile Particles.* Volatile particles collected on filters are often lost during shipment and/or storage of the filters prior to the post-sampling weighing³. Although shipment or storage of loaded filters is sometimes unavoidable, filters should be reweighed as soon as practical to minimize these losses.

6.2 *Artifacts.* Positive errors in PM₁₀ concentration measurements may result from retention of gaseous species on filters^{4,5}. Such errors include the retention of sulfur dioxide and nitric acid. Retention of sulfur dioxide on filters, followed by oxidation to sulfate, is referred to as artifact sulfate formation, a phenomenon which increases with increasing filter alkalinity⁶. Little or no artifact sulfate formation should occur using filters that meet the alkalinity specification in section 7.2.4 of this appendix. Artifact nitrate formation, resulting primarily from retention of nitric acid, occurs to varying degrees on many filter types, including glass fiber, cellulose ester, and many quartz fiber filters^{5,7,8,9,10}. Loss of true atmospheric particulate nitrate during or following sampling may also occur due to dissociation or chemical reaction. This phenomenon has been observed on Teflon[®] filters⁸ and inferred for quartz fiber filters^{11,12}. The magnitude of nitrate artifact errors in PM₁₀ mass concentration measurements will vary with location and ambient temperature; however, for most sampling locations, these errors are expected to be small.

6.3 *Humidity.* The effects of ambient humidity on the sample are unavoidable. The filter equilibration procedure in section 9.0 of this appendix is designed to minimize the effects of moisture on the filter medium.

6.4 *Filter Handling.* Careful handling of filters between presampling and postsampling weighings is necessary to avoid errors due to damaged filters or loss of collected particles from the filters. Use of a filter cartridge or cassette may reduce the magnitude of these errors. Filters must also meet the integrity specification in section 7.2.3 of this appendix.

6.5 *Flow Rate Variation.* Variations in the sampler's operating flow rate may alter the particle

size discrimination characteristics of the sampler inlet. The magnitude of this error will depend on the sensitivity of the inlet to variations in flow rate and on the particle distribution in the atmosphere during the sampling period. The use of a flow control device, under section 7.1.3 of this appendix, is required to minimize this error.

6.6 *Air Volume Determination.* Errors in the air volume determination may result from errors in the flow rate and/or sampling time measurements. The flow control device serves to minimize errors in the flow rate determination, and an elapsed time meter, under section 7.1.5 of this appendix, is required to minimize the error in the sampling time measurement.

7.0 Apparatus.

7.1 PM₁₀ Sampler.

7.1.1 The sampler shall be designed to:

(a) Draw the air sample into the sampler inlet and through the particle collection filter at a uniform face velocity.

(b) Hold and seal the filter in a horizontal position so that sample air is drawn downward through the filter.

(c) Allow the filter to be installed and removed conveniently.

(d) Protect the filter and sampler from precipitation and prevent insects and other debris from being sampled.

(e) Minimize air leaks that would cause error in the measurement of the air volume passing through the filter.

(f) Discharge exhaust air at a sufficient distance from the sampler inlet to minimize the sampling of exhaust air.

(g) Minimize the collection of dust from the supporting surface.

7.1.2 The sampler shall have a sample air inlet system that, when operated within a specified flow rate range, provides particle size discrimination characteristics meeting all of the applicable performance specifications prescribed in part 53 of this chapter. The sampler inlet shall show no significant wind direction dependence. The latter requirement can generally be satisfied by an inlet shape that is circularly symmetrical about a vertical axis.

7.1.3 The sampler shall have a flow control device capable of maintaining the sampler's operating flow rate within the flow rate limits specified for the sampler inlet over normal variations in line voltage and filter pressure drop.

7.1.4 The sampler shall provide a means to measure the total flow rate during the sampling period. A continuous flow recorder is recommended but not required. The flow measurement device shall be accurate to ±2 percent.

7.1.5 A timing/control device capable of starting and stopping the sampler shall be used to obtain a sample collection period of 24 ±1 hr (1,440 ±60 min). An elapsed time meter, accurate to within ±15 minutes, shall be used to measure sampling time. This meter is optional for samplers with continuous flow recorders if the sampling time measurement obtained by means of the recorder meets the ±15 minute accuracy specification.

7.1.6 The sampler shall have an associated operation or instruction manual as required by part 53 of this chapter which includes detailed instructions on the calibration, operation, and maintenance of the sampler.

7.2 Filters.

7.2.1 *Filter Medium.* No commercially available filter medium is ideal in all respects for all samplers. The user's goals in sampling

determine the relative importance of various filter characteristics, e.g., cost, ease of handling, physical and chemical characteristics, etc., and, consequently, determine the choice among acceptable filters. Furthermore, certain types of filters may not be suitable for use with some samplers, particularly under heavy loading conditions (high mass concentrations), because of high or rapid increase in the filter flow resistance that would exceed the capability of the sampler's flow control device. However, samplers equipped with automatic filter-changing mechanisms may allow use of these types of filters. The specifications given below are minimum requirements to ensure acceptability of the filter medium for measurement of PM₁₀ mass concentrations. Other filter evaluation criteria should be considered to meet individual sampling and analysis objectives.

7.2.2 *Collection Efficiency.* ≥99 percent, as measured by the DOP test (ASTM-2986) with 0.3 μm particles at the sampler's operating face velocity.

7.2.3 *Integrity.* ±5 μg/m³ (assuming sampler's nominal 24-hour air sample volume). Integrity is measured as the PM₁₀ concentration equivalent corresponding to the average difference between the initial and the final weights of a random sample of test filters that are weighed and handled under actual or simulated sampling conditions, but have no air sample passed through them, i.e., filter blanks. As a minimum, the test procedure must include initial equilibration and weighing, installation on an inoperative sampler, removal from the sampler, and final equilibration and weighing.

7.2.4 *Alkalinity.* <25 microequivalents/gram of filter, as measured by the procedure given in reference 13 of section 12.0 of this appendix following at least two months storage in a clean environment (free from contamination by acidic gases) at room temperature and humidity.

7.3 *Flow Rate Transfer Standard.* The flow rate transfer standard must be suitable for the sampler's operating flow rate and must be calibrated against a primary flow or volume standard that is traceable to the National Institute of Standard and Technology (NIST). The flow rate transfer standard must be capable of measuring the sampler's operating flow rate with an accuracy of ±2 percent.

7.4 *Filter Conditioning Environment.*

7.4.1 *Temperature range.* 15 to 30 C.

7.4.2 *Temperature control.* ±3 C.

7.4.3 *Humidity range.* 20% to 45% RH.

7.4.4 *Humidity control.* ±5% RH.

7.5 *Analytical Balance.* The analytical balance must be suitable for weighing the type and size of filters required by the sampler. The range and sensitivity required will depend on the filter tare weights and mass loadings. Typically, an analytical balance with a sensitivity of 0.1 mg is required for high volume samplers (flow rates >0.5 m³/min). Lower volume samplers (flow rates <0.5 m³/min) will require a more sensitive balance.

8.0 *Calibration.*

8.1 *General Requirements.*

8.1.1 Calibration of the sampler's flow measurement device is required to establish traceability of subsequent flow measurements to a primary standard. A flow rate transfer standard calibrated against a primary flow or volume standard shall be used to calibrate or verify the accuracy of the sampler's flow measurement device.

8.1.2 Particle size discrimination by inertial separation requires that specific air velocities be

maintained in the sampler's air inlet system. Therefore, the flow rate through the sampler's inlet must be maintained throughout the sampling period within the design flow rate range specified by the manufacturer. Design flow rates are specified as actual volumetric flow rates, measured at existing conditions of temperature and pressure (Q_a).

8.2 *Flow Rate Calibration Procedure.*

8.2.1 PM₁₀ samplers employ various types of flow control and flow measurement devices. The specific procedure used for flow rate calibration or verification will vary depending on the type of flow controller and flow rate indicator employed. Calibration is in terms of actual volumetric flow rates (Q_a) to meet the requirements of section 8.1 of this appendix. The general procedure given here serves to illustrate the steps involved in the calibration. Consult the sampler manufacturer's instruction manual and reference 2 of section 12.0 of this appendix for specific guidance on calibration. Reference 14 of section 12.0 of this appendix provides additional information on various other measures of flow rate and their interrelationships.

8.2.2 Calibrate the flow rate transfer standard against a primary flow or volume standard traceable to NIST. Establish a calibration relationship, e.g., an equation or family of curves, such that traceability to the primary standard is accurate to within 2 percent over the expected range of ambient conditions, i.e., temperatures and pressures, under which the transfer standard will be used. Recalibrate the transfer standard periodically.

8.2.3 Following the sampler manufacturer's instruction manual, remove the sampler inlet and connect the flow rate transfer standard to the sampler such that the transfer standard accurately measures the sampler's flow rate. Make sure there are no leaks between the transfer standard and the sampler.

8.2.4 Choose a minimum of three flow rates (actual m³/min), spaced over the acceptable flow rate range specified for the inlet, under section 7.1.2 of the appendix, that can be obtained by suitable adjustment of the sampler flow rate. In accordance with the sampler manufacturer's instruction manual, obtain or verify the calibration relationship between the flow rate (actual m³/min) as indicated by the transfer standard and the sampler's flow indicator response. Record the ambient temperature and barometric pressure. Temperature and pressure corrections to subsequent flow indicator readings may be required for certain types of flow measurement devices. When such corrections are necessary, correction on an individual or daily basis is preferable. However, seasonal average temperature and average barometric pressure for the sampling site may be incorporated into the sampler calibration to avoid daily corrections. Consult the sampler manufacturer's instruction manual and reference 2 in section 12.0 of this appendix for additional guidance.

8.2.5 Following calibration, verify that the sampler is operating at its design flow rate (actual m³/min) with a clean filter in place.

8.2.6 Replace the sampler inlet.

9.0 *Procedure.*

9.1 The sampler shall be operated in accordance with the specific guidance provided in the sampler manufacturer's instruction manual and in reference 2 in section 12.0 of this appendix. The general procedure given here assumes that the sampler's flow rate calibration is based on flow rates at ambient conditions (Q_a) and serves to illustrate the steps involved in the operation of a PM₁₀ sampler.

9.2 Inspect each filter for pinholes, particles, and other imperfections. Establish a filter information record and assign an identification number to each filter.

9.3 Equilibrate each filter in the conditioning environment (see 7.4) for at least 24 hours.

9.4 Following equilibration, weigh each filter and record the presampling weight with the filter identification number.

9.5 Install a preweighed filter in the sampler following the instructions provided in the sampler manufacturer's instruction manual.

9.6 (a) Turn on the sampler and allow it to establish run-temperature conditions. Record the flow indicator reading and, if needed, the ambient temperature and barometric pressure. Determine the sampler flow rate (actual m³/min) in accordance with the instructions provided in the sampler manufacturer's instruction manual.

(b) Note: No onsite temperature or pressure measurements are necessary if the sampler's flow indicator does not require temperature or pressure corrections or if seasonal average temperature and average barometric pressure for the sampling site are incorporated into the sampler calibration, under section 8.2.4 of this appendix. If individual or daily temperature and pressure corrections are required, ambient temperature and barometric pressure can be obtained by on-site measurements or from a nearby weather station. Barometric pressure readings obtained from airports must be station pressure, not corrected to sea level, and may need to be corrected for differences in elevation between the sampling site and the airport.

9.7 If the flow rate is outside the acceptable range specified by the manufacturer, check for leaks, and if necessary, adjust the flow rate to the specified setpoint. Stop the sampler.

9.8 Set the timer to start and stop the sampler at appropriate times. Set the elapsed time meter to zero or record the initial meter reading.

9.9 Record the sample information (site location or identification number, sample date, filter identification number, and sampler model and serial number).

9.10 Sample for 24±1 hours.

9.11 Determine and record the average flow rate (Q_a) in actual m³/min for the sampling period in accordance with the instructions provided in the sampler manufacturer's instruction manual. Record the elapsed time meter final reading and, if needed, the average ambient temperature and barometric pressure for the sampling period, in note following section 9.6 of this appendix.

9.12 Carefully remove the filter from the sampler, following the sampler manufacturer's instruction manual. Touch only the outer edges of the filter.

9.13 Place the filter in a protective holder or container, e.g., petri dish, glassine envelope, or manila folder.

9.14 Record any factors such as meteorological conditions, construction activity, fires or dust storms, etc., that might be pertinent to the measurement on the filter information record.

9.15 Transport the exposed sample filter to the filter conditioning environment as soon as possible for equilibration and subsequent weighing.

9.16 Equilibrate the exposed filter in the conditioning environment for at least 24 hours under the same temperature and humidity conditions used for presampling filter equilibration (see section 9.3 of this appendix).

9.17 Immediately after equilibration, reweigh the filter and record the postsampling weight with the filter identification number.

10.0 *Sampler Maintenance.*

10.1 The PM₁₀ sampler shall be maintained in strict accordance with the maintenance procedures specified in the sampler manufacturer's instruction manual.

11.0 *Calculations.*

11.1 Calculate the total volume of air sampled as:

$$V = Q_a t$$

where:

V = total air sampled, at ambient temperature and pressure, m³;

Q_a = average sample flow rate at ambient temperature and pressure, m³/min; and

t = sampling time, min.

11.2 (a) Calculate the PM₁₀ concentration as:

$$PM_{10} = (W_f - W_i) \times 10^6 / V$$

where:

PM₁₀ = mass concentration of PM₁₀, μg/m³;

W_f, W_i = final and initial weights of filter collecting PM₁₀ particles, g; and

10⁶ = conversion of g to μg.

(b) Note: If more than one size fraction in the PM₁₀ size range is collected by the sampler, the sum of the net weight gain by each collection filter [$\sum(W_f - W_i)$] is used to calculate the PM₁₀ mass concentration.

12.0 *References.*

1. Quality Assurance Handbook for Air Pollution Measurement Systems, Volume I, Principles. EPA-600/9-76-005, March 1976. Available from CERL, ORD Publications, U.S. Environmental Protection Agency, 26 West St. Clair Street, Cincinnati, OH 45268.

2. Quality Assurance Handbook for Air Pollution Measurement Systems, Volume II, Ambient Air Specific Methods. EPA-600/4-77-027a, May 1977. Available from CERL, ORD Publications, U.S. Environmental Protection Agency, 26 West St. Clair Street, Cincinnati, OH 45268.

3. Clement, R.E., and F.W. Karasek. Sample Composition Changes in Sampling and Analysis of Organic Compounds in Aerosols. *Int. J. Environ. Analyt. Chem.*, 7:109, 1979.

4. Lee, R.E., Jr., and J. Wagman. A Sampling Anomaly in the Determination of Atmospheric Sulfate Concentration. *Amer. Ind. Hyg. Assoc. J.*, 27:266, 1966.

5. Appel, B.R., S.M. Wall, Y. Tokiwa, and M. Haik. Interference Effects in Sampling Particulate Nitrate in Ambient Air. *Atmos. Environ.*, 13:319, 1979.

6. Coutant, R.W. Effect of Environmental Variables on Collection of Atmospheric Sulfate. *Environ. Sci. Technol.*, 11:873, 1977.

7. Spicer, C.W., and P. Schumacher. Interference in Sampling Atmospheric Particulate Nitrate. *Atmos. Environ.*, 11:873, 1977.

8. Appel, B.R., Y. Tokiwa, and M. Haik. Sampling of Nitrates in Ambient Air. *Atmos. Environ.*, 15:283, 1981.

9. Spicer, C.W., and P.M. Schumacher. Particulate Nitrate: Laboratory and Field Studies of Major Sampling Interferences. *Atmos. Environ.*, 13:543, 1979.

10. Appel, B.R. Letter to Larry Purdue, U.S. EPA, Environmental Monitoring and Support Laboratory. March 18, 1982, Docket No. A-82-37, II-1-1.

11. Pierson, W.R., W.W. Brachaczek, T.J. Korniski, T.J. Truex, and J.W. Butler. Artifact

Formation of Sulfate, Nitrate, and Hydrogen Ion on Backup Filters: Allegheny Mountain Experiment. *J. Air Pollut. Control Assoc.*, 30:30, 1980.

12. Dunwoody, C.L. Rapid Nitrate Loss From PM₁₀ Filters. *J. Air Pollut. Control Assoc.*, 36:817, 1986.

13. Harrell, R.M. Measuring the Alkalinity of Hi-Vol Air Filters. EMSL/RTP-SOP-QAD-534, October 1985. Available from the U.S. Environmental Protection Agency, EMSL/QAD, Research Triangle Park, NC 27711.

14. Smith, F., P.S. Wohlschlegel, R.S.C. Rogers, and D.J. Mulligan. Investigation of Flow Rate Calibration Procedures Associated With the High Volume Method for Determination of Suspended Particulates. EPA-600/4-78-047, U.S. Environmental Protection Agency, Research Triangle Park, NC 27711, 1978.

8. Appendix N is added to read as follows:

Appendix N to Part 50—Interpretation of the National Ambient Air Quality Standards for Particulate Matter

1.0 *General.*

(a) This appendix explains the data handling conventions and computations necessary for determining when the annual and 24-hour primary and secondary national ambient air quality standards for PM specified in § 50.7 of this chapter are met. Particulate matter is measured in the ambient air as PM₁₀ and PM_{2.5} (particles with an aerodynamic diameter less than or equal to a nominal 10 and 2.5 micrometers, respectively) by a reference method based on Appendix M of this part for PM₁₀ and on Appendix L of this part for PM_{2.5}, as applicable, and designated in accordance with part 53 of this chapter, or by an equivalent method designated in accordance with part 53 of this chapter. Data handling and computation procedures to be used in making comparisons between reported PM₁₀ and PM_{2.5} concentrations and the levels of the PM standards are specified in the following sections.

(b) Data resulting from uncontrollable or natural events, for example structural fires or high winds, may require special consideration. In some cases, it may be appropriate to exclude these data because they could result in inappropriate values to compare with the levels of the PM standards. In other cases, it may be more appropriate to retain the data for comparison with the level of the PM standards and then allow the EPA to formulate the appropriate regulatory response. Whether to exclude, retain, or make adjustments to the data affected by uncontrollable or natural events is subject to the approval of the appropriate Regional Administrator.

(c) The terms used in this appendix are defined as follows:

Average and *mean* refer to an arithmetic mean.

Daily value for PM refers to the 24-hour average concentration of PM calculated or measured from midnight to midnight (local time) for PM₁₀ or PM_{2.5}.

Designated monitors are those monitoring sites designated in a State PM Monitoring Network Description for spatial averaging in areas opting for spatial averaging in accordance with part 58 of this chapter.

98th percentile (used for PM_{2.5}) means the daily value out of a year of monitoring data below which 98 percent of all values in the group fall.

99th percentile (used for PM₁₀) means the daily value out of a year of monitoring data below which 99 percent of all values in the group fall.

Year refers to a calendar year.

(d) Sections 2.1 and 2.5 of this appendix contain data handling instructions for the option of using a spatially averaged network of monitors for the annual standard. If spatial averaging is not considered for an area, then the spatial average is equivalent to the annual average of a single site and is treated accordingly in subsequent calculations. For example, paragraph (a)(3) of section 2.1 of this appendix could be eliminated since the spatial average would be equivalent to the annual average.

2.0 *Comparisons with the PM_{2.5} Standards.*

2.1 *Annual PM_{2.5} Standard.*

(a) The annual PM_{2.5} standard is met when the 3-year average of the spatially averaged annual means is less than or equal to 15.0 μg/m³. The 3-year average of the spatially averaged annual means is determined by averaging quarterly means at each monitor to obtain the annual mean PM_{2.5} concentrations at each monitor, then averaging across all designated monitors, and finally averaging for 3 consecutive years. The steps can be summarized as follows:

(1) Average 24-hour measurements to obtain quarterly means at each monitor.

(2) Average quarterly means to obtain annual means at each monitor.

(3) Average across designated monitoring sites to obtain an annual spatial mean for an area (this can be one site in which case the spatial mean is equal to the annual mean).

(4) Average 3 years of annual spatial means to obtain a 3-year average of spatially averaged annual means.

(b) In the case of spatial averaging, 3 years of spatial averages are required to demonstrate that the standard has been met. Designated sites with less than 3 years of data shall be included in spatial averages for those years that data completeness requirements are met. For the annual PM_{2.5} standard, a year meets data completeness requirements when at least 75 percent of the scheduled sampling days for each quarter have valid data. However, years with high concentrations and more than a minimal amount of data (at least 11 samples in each quarter) shall not be ignored just because they are comprised of quarters with less than complete data. Thus, in computing annual spatially averaged means, years containing quarters with at least 11 samples but less than 75 percent data completeness shall be included in the computation if the resulting spatially averaged annual mean concentration (rounded according to the conventions of section 2.3 of this appendix) is greater than the level of the standard.

(c) Situations may arise in which there are compelling reasons to retain years containing quarters which do not meet the data completeness requirement of 75 percent or the minimum number of 11 samples. The use of less than complete data is subject to the approval of the appropriate Regional Administrator.

(d) The equations for calculating the 3-year average annual mean of the PM_{2.5} standard are given in section 2.5 of this appendix.

2.2 *24-Hour PM_{2.5} Standard.*

(a) The 24-hour PM_{2.5} standard is met when the 3-year average of the 98th percentile values at each monitoring site is less than or equal to 65 μg/m³. This comparison shall be based on 3 consecutive, complete years of air quality data. A year meets data completeness requirements when at least 75 percent of the scheduled sampling days for each quarter have valid data. However, years with high concentrations shall not be ignored just because they are comprised of quarters with less than complete data. Thus, in computing the 3-year

average 98th percentile value, years containing quarters with less than 75 percent data completeness shall be included in the computation if the annual 98th percentile value (rounded according to the conventions of section 2.3 of this appendix) is greater than the level of the standard.

(b) Situations may arise in which there are compelling reasons to retain years containing quarters which do not meet the data completeness requirement. The use of less than complete data is subject to the approval of the appropriate Regional Administrator.

(c) The equations for calculating the 3-year average of the annual 98th percentile values is given in section 2.6 of this appendix.

2.3 Rounding Conventions. For the purposes of comparing calculated values to the applicable level of the standard, it is necessary to round the final results of the calculations described in sections 2.5 and 2.6 of this appendix. For the annual PM_{2.5} standard, the 3-year average of the spatially averaged annual means shall be rounded to the nearest 0.1 μg/m³ (decimals 0.05 and greater are rounded up to the next 0.1, and any decimal lower than 0.05 is rounded down to the nearest 0.1). For the 24-hour PM_{2.5} standard, the 3-year average of the annual 98th percentile values shall be rounded to the nearest 1 μg/m³ (decimals 0.5 and greater are rounded up to nearest whole number, and any decimal lower than 0.5 is rounded down to the nearest whole number).

2.4 Monitoring Considerations.

(a) Section 58.13 of this chapter specifies the required minimum frequency of sampling for PM_{2.5}. Exceptions to the specified sampling frequencies, such as a reduced frequency during a season of expected low concentrations, are subject to the approval of the appropriate Regional Administrator. Section 58.14 of 40 CFR part 58 and section 2.8 of Appendix D of 40 CFR part 58, specify which monitors are eligible for making comparisons with the PM standards. In determining a spatial mean using two or more monitoring sites operating in a given year, the annual mean for an individual site may be included in the spatial mean if and only if the mean for that site meets the criterion specified in § 2.8 of Appendix D of 40 CFR part 58. In the event data from an otherwise eligible site is excluded from being averaged with data from other sites on the basis of this criterion, then the 3-year mean from that site shall be compared directly to the annual standard.

(b) For the annual PM_{2.5} standard, when designated monitors are located at the same site and

are reporting PM_{2.5} values for the same time periods, and when spatial averaging has been chosen, their concentrations shall be averaged before an area-wide spatial average is calculated. Such monitors will then be considered as one monitor.

2.5 Equations for the Annual PM_{2.5} Standard.

(a) An annual mean value for PM_{2.5} is determined by first averaging the daily values of a calendar quarter:

Equation 1

$$\bar{x}_{q,y,s} = \frac{1}{n_q} \sum_{i=1}^{n_q} x_{i,q,y,s}$$

where:

$\bar{x}_{q,y,s}$ = the mean for quarter q of year y for site s;

n_q = the number of monitored values in the quarter; and

$x_{i,q,y,s}$ = the ith value in quarter q for year y for site s.

(b) The following equation is then to be used for calculation of the annual mean:

Equation 2

$$\bar{x}_{y,s} = \frac{1}{4} \sum_{q=1}^4 \bar{x}_{q,y,s}$$

where:

$\bar{x}_{y,s}$ = the annual mean concentration for year y (y = 1, 2, or 3) and for site s; and

$\bar{x}_{q,y,s}$ = the mean for quarter q of year y for site s.

(c) (1) The spatially averaged annual mean for year y is computed by first calculating the annual mean for each site designated to be included in a spatial average, $\bar{x}_{y,s}$, and then computing the average of these values across sites:

Equation 3

$$\bar{x}_y = \frac{1}{n_s} \sum_{s=1}^{n_s} \bar{x}_{y,s}$$

where:

\bar{x}_y = the spatially averaged mean for year y;

$\bar{x}_{y,s}$ = the annual mean for year y and site s; and

n_s = the number of sites designated to be averaged.

(2) In the event that an area designated for spatial averaging has two or more sites at the same location producing data for the same time periods, the sites are averaged together before using Equation 3 by:

Equation 4

$$\bar{x}_{y,s^*} = \frac{1}{n_c} \sum_{s=1}^{n_c} \bar{x}_{y,s}$$

where:

\bar{x}_{y,s^*} = the annual mean for year y for the sites at the same location (which will now be considered one site);

n_c = the number of sites at the same location designated to be included in the spatial average; and

$\bar{x}_{y,s}$ = the annual mean for year y and site s.

(d) The 3-year average of the spatially averaged annual means is calculated by using the following equation:

Equation 5

$$\bar{x} = \frac{1}{3} \sum_{y=1}^3 \bar{x}_y$$

where:

\bar{x} = the 3-year average of the spatially averaged annual means; and

\bar{x}_y = the spatially averaged annual mean for year y.

Example 1—Area Designated for Spatial Averaging That Meets the Primary Annual PM_{2.5} Standard.

a. In an area designated for spatial averaging, four designated monitors recorded data in at least 1 year of a particular 3-year period. Using Equations 1 and 2, the annual means for PM_{2.5} at each site are calculated for each year. The following table can be created from the results. Data completeness percentages for the quarter with the fewest number of samples are also shown.

Table 1.—Results from Equations 1 and 2

		Site #1	Site #2	Site #3	Site #4	Spatial mean
Year 1	Annual mean (μg/m ³)	12.7	12.7
	% data completeness	80	0	0	0
Year 2	Annual mean (μg/m ³)	12.6	17.5	15.2	15.05
	% data completeness	90	63	38	0
Year 3	Annual mean (μg/m ³)	12.5	18.5	14.1	16.9	15.50
	% data completeness	90	80	85	50
3-year mean		14.42

b. The data from these sites are averaged in the order described in section 2.1 of this appendix. Note that the annual mean from site #3 in year 2 and the annual mean from site #4 in year 3 do not meet the 75 percent data completeness criteria. Assuming the 38 percent data completeness represents a quarter with fewer than 11 samples, site #3 in year 2 does not meet the minimum data

completeness requirement of 11 samples in each quarter. The site is therefore excluded from the calculation of the spatial mean for year 2. However, since the spatial mean for year 3 is above the level of the standard and the minimum data requirement of 11 samples in each quarter has been met, the annual mean from site #4 in year 3 is included in the calculation of the spatial mean for year 3 and

in the calculation of the 3-year average. The 3-year average is rounded to 14.4 μg/m³, indicating that this area meets the annual PM_{2.5} standard.

Example 2—Area With Two Monitors at the Same Location That Meets the Primary Annual PM_{2.5} Standard.

a. In an area designated for spatial averaging, six designated monitors, with two monitors at the same

location (#5 and #6), recorded data in a particular 3-year period. Using Equations 1 and 2, the annual means for PM_{2.5} are calculated for each year. The following table can be created from the results.

Table 2.—Results From Equations 1 and 2

Annual mean (µg/m ³)	Site #1	Site #2	Site #3	Site #4	Site #5	Site #6	Average of #5 and #6	Spatial mean
Year 1	12.9	9.9	12.6	11.1	14.5	14.6	14.55	12.21
Year 2	14.5	13.3	12.2	10.9	16.1	16.0	16.05	13.39
Year 3	14.4	12.4	11.5	9.7	12.3	12.1	12.20	12.04
3-Year mean	12.55

b. The annual means for sites #5 and #6 are averaged together using Equation 4 before the spatial average is calculated using Equation 3 since they are in the same location. The 3-year mean is rounded to 12.6 µg/m³, indicating that this area meets the annual PM_{2.5} standard.

Example 3—Area With a Single Monitor That Meets the Primary Annual PM_{2.5} Standard.

a. Given data from a single monitor in an area, the calculations are as follows. Using Equations 1 and 2, the annual means for PM_{2.5} are calculated

for each year. If the annual means are 10.28, 17.38, and 12.25 µg/m³, then the 3-year mean is:

$$\bar{x} = (1/3) \times (10.28 + 17.38 + 12.25) = 13.303 \mu\text{g}/\text{m}^3.$$

b. This value is rounded to 13.3, indicating that this area meets the annual PM_{2.5} standard.

2.6 Equations for the 24-Hour PM_{2.5} Standard.

(a) When the data for a particular site and year meet the data completeness requirements in section 2.2 of this appendix, calculation of the 98th percentile is accomplished by the following steps. All the daily values from a particular site and year comprise a series of values (x₁, x₂, x₃, ..., x_n), that can be sorted into a series where each number is equal to or larger than the preceding number (x_[1], x_[2], x_[3], ..., x_[n]). In this case, x_[1] is the smallest number and x_[n] is the largest value. The 98th percentile is found from the sorted series of daily values which is ordered from the lowest to the highest number. Compute (0.98) × (n) as the number “i.d”, where “i” is the integer part of the result and “d” is the decimal part of the result. The 98th percentile value for year y, P_{0.98, y}, is given by Equation 6:

Equation 6

$$P_{0.98,y} = X_{[i+1]}$$

where:

P_{0.98,y} = 98th percentile for year y;

x_[i+1] = the (i+1)th number in the ordered series of numbers; and

i = the integer part of the product of 0.98 and n.

(b) The 3-year average 98th percentile is then calculated by averaging the annual 98th percentiles:

Equation 7

$$P_{0.98} = \frac{\sum_{y=1}^3 P_{0.98,y}}{3}$$

(c) The 3-year average 98th percentile is rounded according to the conventions in section 2.3 of this appendix before a comparison with the standard is made.

Example 4—Ambient Monitoring Site With Everyday Sampling That Meets the Primary 24-Hour PM_{2.5} Standard.

a. In each year of a particular 3 year period, varying numbers of daily PM_{2.5} values (e.g., 281, 304, and 296) out of a possible 365 values were recorded at a particular site with the following ranked values (in µg/m³):

Table 3.—Ordered Monitoring Data For 3 Years

Year 1		Year 2		Year 3	
j rank	X _j value	j rank	X _j value	j rank	X _j value
275	57.9	296	54.3	290	66.0
276	59.0	297	57.1	291	68.4
277	62.2	298	63.0	292	69.8

b. Using Equation 6, the 98th percentile values for each year are calculated as follows:

$$0.98 \times 281 = 275.38 \Rightarrow i + 1 = 276 \Rightarrow P_{0.98,1} = X_{[276]} = 59.0 \mu\text{g}/\text{m}^3$$

$$0.98 \times 304 = 297.92 \Rightarrow i + 1 = 298 \Rightarrow P_{0.98,2} = X_{[298]} = 63.0 \mu\text{g}/\text{m}^3$$

US EPA ARCHIVE DOCUMENT

$$0.98 \times 296 = 290.07 \Rightarrow i + 1 = 291 \Rightarrow P_{0.98,3} = X_{[291]} = 68.4 \mu\text{g} / \text{m}^3$$

c. 1. Using Equation 7, the 3-year average 98th percentile is calculated as follows:

$$P_{0.98} = \frac{59.0 + 63.0 + 68.4}{3} = 63.46 \mu\text{g} / \text{m}^3, \text{ which rounds to } 63 \mu\text{g} / \text{m}^3.$$

2. Therefore, this site meets the 24-hour $\text{PM}_{2.5}$ standard.

3.0 Comparisons with the PM_{10} Standards.

3.1 Annual PM_{10} Standard.

(a) The annual PM_{10} standard is met when the 3-year average of the annual mean PM_{10} concentrations at each monitoring site is less than or equal to $50 \mu\text{g}/\text{m}^3$. The 3-year average of the annual means is determined by averaging quarterly means to obtain annual mean PM_{10} concentrations for 3 consecutive, complete years at each monitoring site. The steps can be summarized as follows:

(1) Average 24-hour measurements to obtain a quarterly mean.

(2) Average quarterly means to obtain an annual mean.

(3) Average annual means to obtain a 3-year mean.

(b) For the annual PM_{10} standard, a year meets data completeness requirements when at least 75 percent of the scheduled sampling days for each quarter have valid data. However, years with high concentrations and more than a minimal amount of data (at least 11 samples in each quarter) shall not be ignored just because they are comprised of quarters with less than complete data. Thus, in computing the 3-year average annual mean concentration, years containing quarters with at least 11 samples but less than 75 percent data completeness shall be included in the computation if the annual mean concentration (rounded according to the conventions of section 2.3 of this appendix) is greater than the level of the standard.

(c) Situations may arise in which there are compelling reasons to retain years containing quarters which do not meet the data completeness requirement of 75 percent or the minimum number of 11 samples. The use of less than complete data is subject to the approval of the appropriate Regional Administrator.

(d) The equations for calculating the 3-year average annual mean of the PM_{10} standard are given in section 3.5 of this appendix.

3.2 24-Hour PM_{10} Standard.

(a) The 24-hour PM_{10} standard is met when the 3-year average of the annual 99th percentile values at each monitoring site is less than or equal to 150

$\mu\text{g}/\text{m}^3$. This comparison shall be based on 3 consecutive, complete years of air quality data. A year meets data completeness requirements when at least 75 percent of the scheduled sampling days for each quarter have valid data. However, years with high concentrations shall not be ignored just because they are comprised of quarters with less than complete data. Thus, in computing the 3-year average of the annual 99th percentile values, years containing quarters with less than 75 percent data completeness shall be included in the computation if the annual 99th percentile value (rounded according to the conventions of section 2.3 of this appendix) is greater than the level of the standard.

(b) Situations may arise in which there are compelling reasons to retain years containing quarters which do not meet the data completeness requirement. The use of less than complete data is subject to the approval of the appropriate Regional Administrator.

(c) The equation for calculating the 3-year average of the annual 99th percentile values is given in section 2.6 of this appendix.

3.3 *Rounding Conventions.* For the annual PM_{10} standard, the 3-year average of the annual PM_{10} means shall be rounded to the nearest $1 \mu\text{g}/\text{m}^3$ (decimals 0.5 and greater are rounded up to the next whole number, and any decimal less than 0.5 is rounded down to the nearest whole number). For the 24-hour PM_{10} standard, the 3-year average of the annual 99th percentile values of PM_{10} shall be rounded to the nearest $10 \mu\text{g}/\text{m}^3$ ($155 \mu\text{g}/\text{m}^3$ and greater would be rounded to $160 \mu\text{g}/\text{m}^3$ and $154 \mu\text{g}/\text{m}^3$ and less would be rounded to $150 \mu\text{g}/\text{m}^3$).

3.4 *Monitoring Considerations.* Section 58.13 of this chapter specifies the required minimum frequency of sampling for PM_{10} . Exceptions to the specified sampling frequencies, such as a reduced frequency during a season of expected low concentrations, are subject to the approval of the appropriate Regional Administrator. For making comparisons with the PM_{10} NAAQS, all sites meeting applicable requirements in part 58 of this chapter would be used.

3.5 Equations for the Annual PM_{10} Standard.

(a) An annual arithmetic mean value for PM_{10} is determined by first averaging the 24-hour values of a calendar quarter using the following equation:

Equation 8

$$\bar{x}_{q,y} = \frac{1}{n_q} \sum_{i=1}^{n_q} x_{i,q,y}$$

where:

$\bar{x}_{q,y}$ = the mean for quarter q of year y;

n_q = the number of monitored values in the quarter; and

$x_{i,q,y}$ = the ith value in quarter q for year y.

(b) The following equation is then to be used for calculation of the annual mean:

Equation 9

$$\bar{x}_y = \frac{1}{4} \sum_{q=1}^4 \bar{x}_{q,y}$$

where:

\bar{x}_y = the annual mean concentration for year y, (y=1, 2, or 3); and

$x_{q,y}$ = the mean for a quarter q of year y.

(c) The 3-year average of the annual means is calculated by using the following equation:

Equation 10

$$\bar{x} = \frac{1}{3} \sum_{y=1}^3 \bar{x}_y$$

where:

\bar{x} = the 3-year average of the annual means; and

\bar{x}_y = the annual mean for calendar year y.

Example 5—Ambient Monitoring Site That Does Not Meet the Annual PM_{10} Standard.

a. Given data from a PM_{10} monitor and using Equations 8 and 9, the annual means for PM_{10} are calculated for each year. If the annual means are 52.42, 82.17, and $63.23 \mu\text{g}/\text{m}^3$, then the 3-year average annual mean is:

$$\bar{x} = (1/3) \times (52.42 + 82.17 + 63.23) = 65.94, \text{ which is rounded to } 66 \mu\text{g} / \text{m}^3.$$

b. Therefore, this site does not meet the annual PM_{10} standard.

3.6 Equation for the 24-Hour PM_{10} Standard.

(a) When the data for a particular site and year meet the data completeness requirements in section 3.2 of this appendix, calculation of the 99th percentile is accomplished by the following steps. All the daily values from a particular site and year comprise a series of values ($x_1, x_2, x_3, \dots, x_n$) that can be sorted into a series where each number is

equal to or larger than the preceding number ($x_{[1]}, x_{[2]}, x_{[3]}, \dots, x_{[n]}$). In this case, $x_{[1]}$ is the smallest number and $x_{[n]}$ is the largest value. The 99th percentile is found from the sorted series of daily values which is ordered from the lowest to the highest number. Compute $(0.99) \times (n)$ as the number "i.d", where "i" is the integer part of the result and "d" is the decimal part of the result. The 99th percentile value for year y, $P_{0.99,y}$, is given by Equation 11:

Equation 11

$$P_{0.99,y} = X_{[i+1]}$$

where:

$P_{0.99,y}$ = the 99th percentile for year y;

$x_{[i+1]}$ = the $(i+1)$ th number in the ordered series of numbers; and

i = the integer part of the product of 0.99 and n .

(b) The 3-year average 99th percentile value is then calculated by averaging the annual 99th percentiles:

Equation 12

$$P_{0.99} = \frac{\sum_{y=1}^3 P_{0.99,y}}{3}$$

(c) The 3-year average 99th percentile is rounded according to the conventions in section 3.3 of this appendix before a comparison with the standard is made.

Example 6—Ambient Monitoring Site With Sampling Every Sixth Day That Meets the Primary 24-Hour PM₁₀ Standard.

a. In each year of a particular 3 year period, varying numbers of PM₁₀ daily values (e.g., 110, 98, and 100) out of a possible 121 daily values were recorded at a particular site with the following ranked values (in $\mu\text{g}/\text{m}^3$):

Table 4.—Ordered Monitoring Data For 3 Years

Year 1		Year 2		Year 3	
j rank	X_j value	j rank	X_j value	j rank	X_j value
108	120	96	143	98	140
109	128	97	148	99	144
110	130	98	150	100	147

b. Using Equation 11, the 99th percentile values for each year are calculated as follows:

$$0.99 \times 110 = 108.9 \Rightarrow i + 1 = 109 \Rightarrow P_{0.99,1} = X_{[109]} = 128 \mu\text{g} / \text{m}^3$$

$$0.99 \times 98 = 97.02 \Rightarrow i + 1 = 98 \Rightarrow P_{0.99,2} = X_{[98]} = 150 \mu\text{g} / \text{m}^3$$

$$0.99 \times 100 = 99 \Rightarrow i + 1 = 100 \Rightarrow P_{0.99,3} = X_{[100]} = 147 \mu\text{g} / \text{m}^3$$

c. 1. Using Equation 12, the 3-year average 99th percentile is calculated as follows:

$$\frac{128 + 150 + 147}{3} = 141.7 \mu\text{g} / \text{m}^3 \text{ rounds to } 140 \mu\text{g} / \text{m}^3.$$

2. Therefore, this site meets the 24-hour PM₁₀ standard.

[FR Doc. 97-18577 Filed 7-17-97; 8:45 am]

BILLING CODE 6560-50-F