

US EPA ARCHIVE DOCUMENT

# Environmental Technology Verification Report

The Protectoseal Company  
Pin-Tech™ Bubble Tight < 500 ppm  
Relief Vent

Prepared by:

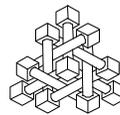

**Southern Research Institute**



Under a Cooperative Agreement With  
U.S. Environmental Protection Agency

US EPA ARCHIVE DOCUMENT

ET ✓ ET ✓ ET ✓

**EPA REVIEW NOTICE**

This report has been peer and administratively reviewed by the U.S. Environmental Protection Agency, and approved for publication. Mention of trade names or commercial products does not constitute endorsement or recommendation for use.



**Greenhouse Gas Technology Verification Center**  
A U.S. EPA Sponsored Environmental Technology Verification Organization

**The Protectoseal Company**  
**Pin-Tech™**  
**Bubble Tight < 500 ppm Relief Vent**

**Technology Verification Report**

**Prepared By:**  
Southern Research Institute  
Greenhouse Gas Technology Verification Center  
PO Box 13825  
Research Triangle Park, NC 27709 USA

Under EPA Cooperative Agreement CR 826311-01-0

U.S. Environmental Protection Agency  
Office of Research and Development  
National Risk Management Research Laboratory  
Air Pollution Prevention and Control Division  
Research Triangle Park, NC 27711 USA

EPA Project Officer: David A. Kirchgessner

TABLE OF CONTENTS

	<u>Page</u>
ACKNOWLEDGMENTS .....	iv
<b>1.0 BACKGROUND AND INTRODUCTION .....</b>	<b>1-1</b>
<b>2.0 TECHNOLOGY DESCRIPTION AND VERIFICATION APPROACH .....</b>	<b>2-1</b>
2.1 TECHNOLOGY DESCRIPTION .....	2-1
2.2 VERIFICATION APPROACH.....	2-3
2.2.1 Laboratory Selection .....	2-3
2.2.2 Test Methods and Set-up .....	2-4
2.2.3 Leak Tightness (Non-Venting Mode) .....	2-6
2.2.4 Set Pressure Accuracy .....	2-7
2.2.5 Repeated Pin Stress Impact .....	2-8
<b>3.0 RESULTS .....</b>	<b>3-1</b>
3.1 LEAK TIGHTNESS RESULTS IN NON-VENT MODE .....	3-1
3.2 SET PRESSURE ACCURACY .....	3-3
3.3 REPEATED PIN STRESS IMPACTS .....	3-4
<b>4.0 SAMPLING AND QC/QA PROCEDURES.....</b>	<b>4-1</b>
4.1 CONCENTRATION MEASUREMENT PERFORMANCE OF THE AUTOFIM II .....	4-1
4.2 PRESSURE MEASUREMENT PERFORMANCE .....	4-4
4.3 TEST COMPLETENESS .....	4-6
4.4 TEST GAS CERTIFICATION .....	4-6
<b>5.0 REFERENCES.....</b>	<b>5-1</b>

**LIST OF APPENDICES**

APPENDIX A .....	Leak Tightness Data for Conventional PRVs.....	<u>Page</u> A-1
------------------	--	--------------------

**LIST OF FIGURES**

Figure 2-1 .....	Cross-Sectional View of a Pin-Tech Device When .....	<u>Page</u> 2-1
	In Non-Vent and Vent Mode	
Figure 2-2.....	The Two Types of Pin-Tech Devices .....	2-2
Figure 2-3.....	Test Apparatus .....	2-5
Figure 3-1 .....	Pin-Tech Performance .....	3-2
Figure 3-2.....	Sample Screening Test Data.....	3-2
Figure 3-3.....	Pin Stressing for 2 in. Direct Acting Pin-Tech .....	3-5
Figure 4-1 .....	Calibration Results for the 0 to 30 psig Pressure Gauge .....	4-5

**LIST OF TABLES**

Table 2-1 .....	PRV Specifications and Test Settings .....	<u>Page</u> 2-6
Table 3-1 .....	Leak Tightness Results (Non-Vent Mode) .....	3-1
Table 3-2 .....	Pressure Relief for Pin-Tech Devices.....	3-4
Table 4-1 .....	Overview of Important Data Quality Indicators .....	4-1
Table 4-2 .....	Performance Criteria for Method 21 Measuring Instruments .....	4-2
Table 4-3 .....	QA Records and Checks.....	4-3
Table 4-4 .....	Test Completeness (runs) .....	4-6

## ACKNOWLEDGMENTS

The Greenhouse Gas Technology Verification Center wishes to thank John Stelling of Stelling Engineering for his assistance in developing the test plan and the test report. Thanks are also extended to Keith Barnett of the U.S. EPA Office of Air Quality Planning and Standards and to the EPA Office of Research and Development's QA team, lead by Nancy Adams. Finally, a special thanks to the Center's Oil and Natural Gas Industry Stakeholder Group, especially Andy Shah of Conoco, Brian Shannon of ARCO Technology, and John Alderman of Cornerstone Environmental for reviewing the test plan and/or the verification report.

## 1.0 BACKGROUND AND INTRODUCTION

The Environmental Technology Verification (ETV) program was established by the United States Environmental Protection Agency (EPA) in response to the belief that there are many viable environmental technologies which are not being used for lack of credible third-party performance evaluation. With the performance data developed under the program, technology procurement and permitting personnel in the United States and abroad will be better equipped to make informed purchasing decisions about environmental technology. In late 1997, EPA selected Southern Research Institute to manage the Greenhouse Gas Technology Verification Center (the Center), which is one of 12 ETV verification organizations. Eleven other ETV verification organizations are currently operating throughout the United States conducting third-party verifications in a wide range of environmental media and industries.

In March of 1998, the Center met with members of the Executive Stakeholder Group. In that meeting, it was decided that the oil and gas industries were good candidates for third-party verification of methane mitigation and monitoring technologies. As a consequence, in June 1998 the Center hosted a meeting in Houston, Texas, with operators and vendors in the oil and natural gas industries. The objectives of the meeting were to gauge the need for verification testing in these industries, identify specific technology testing priorities, identify broadly acceptable verification and testing strategies, and recruit industry specific stakeholders. Since the Houston meeting, a 19 member Oil and Gas Industry Stakeholder Group has been formed, vendors of greenhouse gas (GHG) mitigation devices have been solicited in several technology areas, and verification testing of several compressor leak mitigation devices has been started and completed.

In March of 1999, The Protectoseal Company (Protectoseal) requested independent verification to be conducted on their pressure relief vent technology. Protectoseal's Pin-Tech™ Bubble Tight < 500 ppm Relief Vent (Pin-Tech) is designed to reduce "fugitive" emissions (i.e., emissions from the relief valve under non-venting conditions) from low-pressure storage vessels, such as crude petroleum storage tanks at refineries. The Pin-Tech device differs from conventional PRVs in that a rigid pin is used to hold the sealing piston securely in place during non-venting conditions. The pin is designed to buckle at the relief pressure, allowing the valve to vent when tank safety requires it.

The background information supporting development of the National Emissions Standards for Hazardous Air Pollutants (NESHAP) from petroleum refineries estimated that 9,779 storage tanks are in operation in the United States, with 922 in crude oil service (Radian 1992). These tanks release volatile constituents contained in the crude oil such as methane, ethane, and hydrogen sulfide. If the relief device does not completely seal the tank from the atmosphere, significant amounts of methane and other regulated compounds (e.g., benzene, xylene, and toluene) can be emitted.

Refineries in the United States are subject to state and local emission regulations, and may be subject to certain federal regulations governing emissions from new or modified sources (New Source Performance Standards or NSPS) and emissions of hazardous air pollutants (NESHAP), and Maximum Achievable Control Technology (MACT) Standards, (40 CFR Part 63, Subpart H). These regulations require pressure relief devices to operate in a condition of no detectable emissions when in the normal non-venting mode. That is, having a maximum volatile organic compound (VOC) concentration at the leak interface of less than 500 ppmv (40 CFR Part 60, Subpart GGG).

In keeping with this, the primary goal for this test was to verify that the Pin-Tech device does not allow emissions sufficient to produce a concentration of 500 ppmv at the leak interface during non-venting conditions. A small number of conventional weight-loaded PRVs were tested in the same manner to establish emission reductions, but it was later discovered that this could not be done (to be discussed later). The performance of the Pin-Tech device was also assessed by verifying what the actual relief pressure is compared to that of the design set point and by examining the effect of stressing, or bending the pin as the relief point is approached. These goals resulted in the specification of three verification parameters:

- Leak Tightness: Verify emission performance when the Pin-Tech is in the non-vent mode and that emissions do not exceed the 500 ppmv limit
- Set Pressure Accuracy: Verify the difference between the actual Pin-Tech relief pressure and the design set point
- Repeated Pin Stress Impact: Assess the effect of stressing the pin as the relief point is repeatedly approached

In the original testing strategy, one of the verification goals was to determine potential GHG reductions for Pin-Techs by measuring emission rates for Pin-Tech and subtracting from a determined baseline emission rate for conventional PRVs. Some leak-tightness testing of baseline conventional PRVs was conducted to support this goal, but it was determined that the Center could not determine credible emission rates and emission reductions with the test plan developed to assess the three verification parameters listed above. Some data on leak tightness associated with baseline technologies were collected, and are presented in this report.

Section 2 of this report presents a description of the Pin-Tech device and its operational characteristics, and outlines the test methods used for the verification of each verification parameter. Detailed test methods and procedures are presented in the Testing and Quality Assurance Plan (SRI 1999) for this test. Section 3 presents the test results for each verification parameter. Section 4 presents data quality indicators and assesses overall data quality for the test.

## 2.0 TECHNOLOGY DESCRIPTION AND VERIFICATION APPROACH

### 2.1 TECHNOLOGY DESCRIPTION

The Pin-Tech device is designed for use on any type of low-pressure (< 15 psig) storage tank. Similar to any PRV, its function is to protect the tank from becoming damaged from over-pressurization.

The Pin-Tech device differs from conventional PRVs in that a rigid pin is used to hold the sealing piston securely in place during non-venting conditions. The pin is designed to buckle at the relief pressure, allowing the tank to vent. Figure 2-1 shows the Pin-Tech device in normal service (upper portion of figure) and in the relief condition (lower portion of figure).

**Figure 2-1. Cross-Sectional View of a Pin-Tech Device When in Non-Vent and Vent Mode**  
**Upper View: Device in Non-vent Mode**  
**Lower View: Device in Vent Mode**

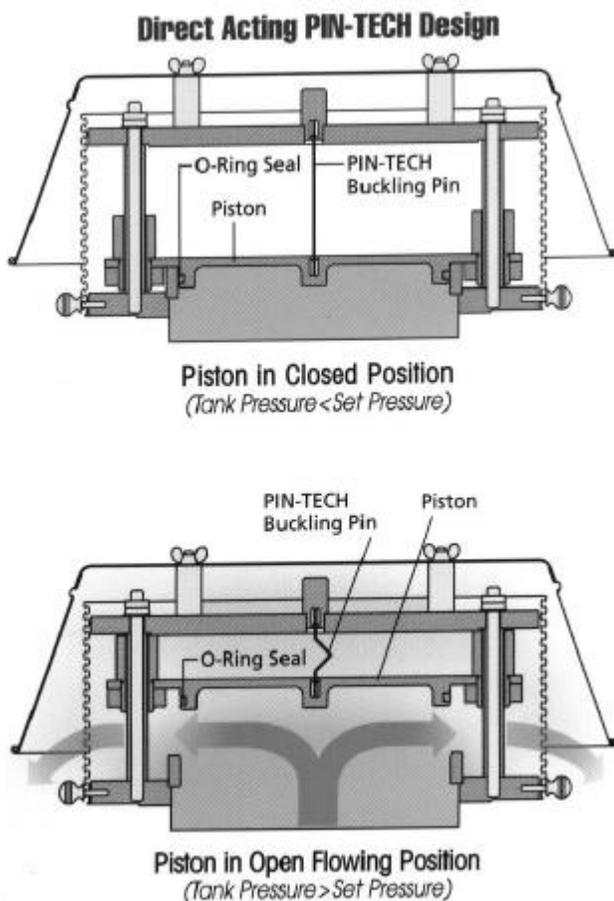

The pins are sized according to the desired relief pressure and are typically constructed of aircraft grade stainless steel (other metals are available). Protectoseal states that the Pin-Tech design provides positive sealing of the tank vapors from the atmosphere if the device has not relieved.

Once the valve has relieved, the pin must be manually replaced before the valve can resume leak-tight performance. Although the piston may return to a closed position after the over-pressurization subsides, only the weight of the piston acts to prevent leaking. There is no pin to ensure a leak-tight seal. This enables the contents in the tank to be vented when the pressure rises sufficiently to lift the piston. The lack of a leak-tight seal is similar to the use of a rupture disk, which is destroyed when the operating pressure reaches a predetermined pressure. A rupture disk is generally applicable to the same low-pressure range as the Pin-Tech design. Also, in both cases, the device will need maintenance before it resumes proper operation. The replacement of the pin for the Pin-Tech design, however, is a simpler and quicker repair than the replacement of the rupture disk. This enables the Pin-Tech device to be back “on-line” more quickly than the rupture disk. For a conventional weight-loaded or spring-loaded PRV, the valve will re-seat after an overpressurization event and no maintenance is necessary, although the valve must be checked to ensure that it has re-seated properly. Limited test results indicate that the sealing capabilities of weight-loaded and spring-loaded PRVs may not prevent emissions in excess of the 500 ppmv limit in the non-vent mode.

Sealing performance of the Pin-Tech device after the pin has buckled was not assessed in this verification since standard operating practice would include inspection and maintenance of the Pin-Tech device after an overpressure event. These devices can be configured with either visible or electronic alarms to indicate that the pin has buckled.

The two types of Pin-Tech devices are the direct-acting (Figure 2-2, foreground) and the diaphragm-assisted (Figure 2-2, background). Both types operate on the same principle; however, the diaphragm-assisted device is used for very low-release set pressures where there may be insufficient pressure in the vessel to buckle the pin. The diaphragm focuses the small pressure increase in the vessel, generating sufficient force to buckle the pin and lift the piston. The performance of both types of devices was assessed in the test.

**Figure 2-2. The Two Types of Pin-Tech Devices**



## 2.2 VERIFICATION APPROACH

As stated in the introduction, the three verification parameters for this test are:

- **Leak Tightness:** Verification of emission performance when the Pin-Tech PRVs are in the non-vent mode and that emissions do not exceed the 500 ppmv screening concentration
- **Set-Pressure Accuracy:** Verification of the difference between the actual Pin-Tech relief pressure and the design set point
- **Repeated Pin Stress Impact:** Assessment of the effect of stressing the pin on the screening value as the relief point is approached

In the original testing strategy, one of the verification goals planned was to determine emission rates, then to determine emission reductions for Pin-Tech PRVs by subtracting Pin-Tech PRV emission rates from baseline emission rates. Baseline emission rates were determined to be those associated with industry standard PRVs used in low-pressure tank applications, such as crude oil storage tanks. Based on EPA data sources, this was determined to be conventional weight-loaded PRVs.

Some leak-tightness testing of baseline conventional PRVs was conducted to support this goal, but it was determined that the Center could not determine credible emission rates and emission reductions with the test plan developed to assess the three verification parameters listed above. The mechanisms effecting long-term emission rates from PRVs are complex, and the Center could not realistically simulate and characterize these mechanisms with the laboratory setting and tank cycles planned for use here. For example, emissions from PRVs can occur when in the non-venting mode (the seals leak), when the tank pressure approaches the relief pressure and the PRV begins to “chatter” (intermittent “burping” of the tank), after overpressurization has occurred and the valve reseats poorly, and through other mechanisms. It was determined that to characterize PRV emission mechanisms for Pin-Tech and baseline (conventional) technologies adequately, more representative tank pressure cycles were needed, longer-term testing would be required, and a large population of conventional PRVs should be tested. Some data on leak tightness associated with baseline technologies were collected, and are presented in Section 3.

In this section, the test approach and test methods used to verify each of the parameters are described. The first parameter, leak tightness, is a regulatory compliance evaluation. The second parameter, set pressure accuracy, is process and procedure oriented. Finally, the impact of repeated pin stressing is an evaluation of the mechanical properties of the components of the Pin-Tech equipment.

### 2.2.1 Laboratory Selection

Field testing at actual tanks was first considered for the verification of relief valves typically used on crude oil tanks. As an alternate to field testing, use of laboratory equipment to simulate tank pressure cycles was also considered. Field testing at actual tank farms was deemed problematic owing to the long tank pressure cycles expected, and the unpredictable nature of tank operations subject to external ambient conditions. Thus, laboratory equipment that could simulate the

appropriate tank pressures was chosen to allow for predictable operations and to ensure that specific valve relief pressures could be achieved numerous times.

Most manufacturing sites that have equipment operating in liquid or vapor phases have pressure relief equipment for safety and insurance purposes. Accordingly, those sites often have calibration and test equipment for PRVs brought on site to facilitate routine relief valve testing. To work around the needs of these manufacturing sites, outside firms provide this important service to manufacturing sites. Mobile testing trailers can be dispatched to the site where the PRVs are tested.

The firm selected for this verification was Southeastern Valve, Inc. of Charlotte, NC. Southeastern Valve, Inc. is an independent firm that services relief valves for process industries. They have calibration and test equipment both at their stationary laboratory in Charlotte and in their mobile calibration trailers. The firm was selected because:

- They have experience in calibrating relief valves, calibrating over 5,000 valves per year,
- They have equipment that can accommodate the gas vapor concentrations typically found in a crude oil storage tank,
- Their equipment is well maintained and their pressure gauges are calibrated to NIST standards within 1 month of the test, and
- They have never conducted work directly for Protectoseal or any other manufacturer of PRVs, eliminating potential conflict of interest concerns.

### **2.2.2 Test Methods and Set-up**

Method 21 (40 CFR 60, Appendix A) is the testing method specified by standards of performance for equipment leaks to determine the need for maintenance, or to assess conformance with the “no detectable emissions” requirement of federally promulgated equipment leak regulations. Method 21 was born from early research efforts to characterize the potential for emissions from fugitive sources (also known as equipment leaks) in the petroleum and chemical process industries. This method was applied to all the PRVs tested as the pressure that they were subjected to was incrementally increased until the device under test relieved.

To apply Method 21 to the valves that were tested, model tank characteristics were specified to represent a typical storage tank that might exist in the crude oil industry. This model considered factors such as tank dimensions, color, and crude oil composition. The model used was based on the stable oil tank model of the Production Tank Emissions Model (GRI 1997).

The Pin-Tech evaluation was conducted in a mobile laboratory designed and equipped for testing pressure relief valves. The laboratory setting allowed the tests to be more effectively controlled than if the tests were conducted in the field on actual tanks. Using a laboratory arrangement, the Center was able to evaluate the performance of the valves under a wider range of pressures under controlled conditions than would be achievable in the field. The test apparatus consisted of a gas

cylinder, pressure regulator, pressure gauge, and receiving tank. The device to be tested was bolted to a fitting on top of the receiving tank. Figure 2-3 shows the test apparatus, and illustrates the concentration measurement technique (known as screening). The gas placed under pressure in the receiving tank was 1.5 percent methane in nitrogen. This concentration was selected using the Production Tank Emissions Model, which estimates the vapor composition in the head space of a typical crude oil storage tank. A range of 3,300 to 22,900 ppmv total hydrocarbon was predicted. Based on this a maximum methane concentration of 15,000 ppmv (1.5 percent) was selected as the target value for testing. The test plan contains details of the modeling.

**Figure 2-3. Test Apparatus**



The tank pressure cycle developed for this series of evaluations involves a low-pressure (0 to 15 psig) process, simulating the storage of crude oil at a petroleum refinery. The equipment tested, accordingly, must be designed to function within these absolute pressure ranges. The Pin-Tech equipment is designed for these operating pressures. Not all conventional equipment, however, is designed to operate in the lower pressure ranges. For example, a spring-actuated relief valve would not normally be selected for such low pressure, but a weight-loaded valve relief would be selected. Thus, the test program considered Pin-Tech valves and weight-loaded PRVs.

The pressure sensors on the test apparatus were critical to this verification test. Because the verification was conducted for valves with fairly widely divergent set points (1 oz/in.<sup>2</sup> up to 15 psig), two different pressure instruments were used. The test contractor supplied a 0 to 30 psig pressure gauge, which is used for routine applications in the mobile laboratory. This device was calibrated at seven points (5 psig increments) within 1 month prior to the test. To handle the lower pressure range, a new U.S. Gauge SEV-2 pressure gauge was acquired from Buffalo Gauge, Inc. This device was calibrated to within 0.2 oz/in.<sup>2</sup> for the entire 0 to 20 oz/in.<sup>2</sup> range by Buffalo Gauge within 1 week of the test.

**2.2.3 Leak Tightness (Non-Venting Mode)**

The Pin-Tech device is intended to reduce overall emissions by maintaining “no detectable emissions” (i.e., having a screening concentration value < 500 ppmv) in the non-venting mode. The goal is to verify that the device operates with no detectable emissions during normal tank operations. The original plan for the verification included assessment of emission rates from Pin-Tech design relief valves and conventional relief valves (weight-loaded only). During testing and analysis, it became clear that emission rate determinations were problematic. To obtain meaningful emission rates, sampling must be done on populations of valves under a range of representative operating conditions. Instead, the measurements were targeted toward compliance with the regulatory requirement, namely the ability to achieve and maintain a condition of no detectable emissions.

Four different Pin-Tech devices were tested. Two were direct-acting and two were diaphragm-assisted. Table 2-1 lists the size of the attachment flange, the valve type, and the set pressure of the devices tested. These valves represent the range of the Protectoseal Pin-Tech product line. Two conventional, weight-loaded PRVs, which had been acquired to conduct the emission rate comparisons, were evaluated for their performance with respect to no detectable emissions over the tank test cycle.

<b>Table 2-1. PRV Specifications and Test Settings</b>			
<b>Device</b>	<b>Size, in.</b>	<b>Pressure set point</b>	<b>Incremental Settings</b>
Pin-Tech #1 (direct-acting)	2	15 psig (240 oz/in. <sup>2</sup> )	Start at ~7 psig and increase by 0.5 psig
Pin-Tech #2 (direct-acting)	24	8.6 psig (138 oz/in. <sup>2</sup> )	Start at ~4 psig and increase by 0.5 psig
Pin-Tech #3 (diaphragm-assisted)	2	2 in. water column (1.15 oz/in. <sup>2</sup> )	Start at 1 in. water column and increase by 1 in.
Pin-Tech #4 (diaphragm-assisted)	24	3 in. water column (1.725 oz/in. <sup>2</sup> )	Start at 1 in. water column and increase by 1 in.

Each PRV was tested by incrementally increasing the pressure on each valve as shown in Table 2-1 until the valve relieved. Hydrocarbon concentration measurements (screening values) were obtained at the leak interface at each pressure set point. The initial pressure was approximately half of the relief set point. The pressure increments were approximately 0.5 psig for the higher pressure valves and approximately 1 in. water column (~0.5 oz/in.<sup>2</sup>) for the low-pressure valves. Screening values were obtained in accordance with EPA Method 21 procedures (40 CFR Part 60, Appendix A). An AutoFim II portable flame ionization detector (FID), was used to measure the screening values. It has a lower detection limit of 0.05 ppmv. This device met all Method 21 performance criteria for leak screening (Section 4.0). In addition to the screening data, the actual relief pressure for each valve was recorded for comparison to the design set pressure.

This procedure represents a departure from the original test plan. The test plan proposed a set of tests based on a pressure range and pressure increments representative of conditions (derived from modeling) for a single representative tank (15 psig set pressure). However, the valves obtained from the vendor represented a variety of sizes and set pressures. The test was modified to accommodate this wider range of conditions. However, due to limitations in the test apparatus (the smallest pressure increment achievable was approximately 0.5 oz/in.<sup>2</sup>), fewer points were collected with the low-pressure devices tested. These and other changes in the original test plan are described in this chapter.

Each test commenced with the valve's being mounted onto Southeastern Valve's testing vessel and establishing a testing start pressure. The test vessel consisted of a small receiving tank that the working gas from a cylinder could slowly be allowed to fill, raising the pressure to a known level. The valve leak interface was then screened using the Autofim II portable FID monitor, making sure to measure concentrations 360 degrees around the valve, perpendicular to the interface. Although the readings were taken at the actual interface for most of the screenings, when the valve was nearing its relief pressure, the probe was not placed on the interface for fear that, when the valve springs open, it could crush the probe tip. For this purpose, there was a 1 in. wire spacer at the end of the probe, which ensured that readings were never being taken more than 1 in. from the valve leak interface.

During valve leak interface testing, the Autofim's digital readout can indicate increasing and decreasing trends, allowing the reader to be sure when the unit has stabilized. If the value on the Autofim begins to increase, the sampler slows the sweep to ensure that the maximum value is captured. In general, the 360 degree sweep takes approximately 3 to 5 minutes to perform for the larger diameter valves and about 1 to 2 minutes for the smaller diameter valves. The readings on the Autofim are called out aloud and were confirmed by personnel from both Southern Research Institute and Southeastern Valve prior to recording. If conflicting values were reached, nothing was recorded and that run was repeated.

As the pressure was set for each device, Southeastern personnel would establish the pressure, announce it to be recorded, and then screening would occur. At the new pressure the interface was re-screened and the maximum value was recorded. This process continued until the device relieved.

Each test run consisted of multiple pressure increments between the starting pressure and relief of the valve. For lower-pressure devices, only two or three pressure increments were possible for the test run. The pressure increments themselves were small, and the absolute set pressure is comparably small, allowing only a limited number of pressure increments. For the higher-pressure devices, the test run consisted of eight to ten pressure increments. Two test runs were planned for each valve. Additional test runs were conducted only if there was not agreement in the results of the first two test runs.

#### **2.2.4 Set Pressure Accuracy**

Each Pin-Tech device was tested to determine how close to the manufacturer's set point the device actually relieved as a test of the set pressure accuracy. For this verification, the pressure to the relief valve was increased stepwise until the valve released. The magnitude of the pressure step was dependent upon the set pressure of the valve, as described below. Each test run began at approximately half the design set point. The pressure in the test equipment was increased very slowly by gradually opening a valve on the supply gas (after the pressure regulator which reduced

the supply pressure to an operable range) to where the valve released; 0.5 psig increase for higher-pressure valves and 0.5 oz increase for lower-pressure valves. The regulator would be opened, the pressure increased to the new level, then the valve of the regulator was closed, and the pressure was read from the gauge. When the valve was heard to open, this was called the relief pressure; this release pressure was then recorded. This procedure was repeated at least three times for each Pin-Tech device. These tests were conducted as part of each of the test runs conducted for the first verification parameter (leak tightness).

In tests on the low-pressure valves, the laboratory's pressure regulation system lacked sufficient control precision to accurately pinpoint the pressure at which buckling occurred. For this reason, a range of estimated relief pressures is given for the low set-pressure devices tested. The range consists of a lower value, the last pressure increment established and recorded before relief; and an upper value, the observed pressure at relief. Because the pressure regulation system could not deliver small incremental pressure increases, when increases occurred, the valve was exposed to a large pressure surge relative to its low set pressure. Given the configuration of the testing system, and the observations of the Center staff during testing, it is likely that the actual relief pressure is below the last pressure increment recorded. It is believed that gas continued to flow into the vessel to a point above the relief pressure momentarily, before the valve opened and relieved, thus giving a higher reading than the actual. The Center is confident that the actual relief pressure is between the upper and lower ends of the range, and use of a range should not be interpreted as a deficiency in the Pin-Tech device. Rather, it represents an inadequacy in the testing equipment used.

### **2.2.5 Repeated Pin Stress Impact**

Contrasted with a spring or weight in a conventional relief valve, the Pin-Tech device uses a metal pin as the operative element for ensuring a secure seal. The pin is designed to fail at the relieving pressure. As with any mechanical device, however, the pin can be deflected at or near the design set pressure of the device. This verification evaluation was designed to assess the performance and the leak tightness of the valve under repeated stressing of the pin. The evaluation of leak tightness at continuous or chronic operation near the design set pressure of the relief valve is also compliance related. For conventional valves (spring-loaded or weight-loaded), operation at or near the set pressure can lead to semi-continuous raising and lowering of the valve piston, commonly known as chattering from the noise made by the rattling of the valve plug on the seat. Relief valves operating in chattering mode yield greater concentrations of emissions than those operating with the piston seated in the proper non-venting position. This verification, therefore, assessed concentrations at the potential leak interface for the Pin-Tech valves when the pin was stressed repeatedly, simulating operation at or near the set pressure of the valve.

From observations during testing of the Pin-Tech devices used in this program, the pin begins to bend or deflect at approximately 70 percent of the design set pressure.

Repeated pin stress tests were planned for all Pin-Tech designs. However, only a single set of four tests was performed on the 2 in. direct-acting Pin-Tech device because deflection was most clearly noticed for the size of the pin for this valve. The pin size for the other PRVs were either too large or too small to see variations in the degree of deflection in the pin. Specifically, the operating pressure range for the diaphragm-assisted relief valves (less than 20 oz/in.<sup>2</sup>) was so small as to render the repeated pin stress testing moot; the pin would fail (as designed) before the pressure could be throttled down to a normal operating pressure. Also, the valve operating at a

greater pressure was larger in diameter and shorter, effectively mitigating the ability to detect deflections with the naked eye.

Each test started at half the design relief pressure. The pressure was increased in approximately 0.5 psig increments, with screening concentration measurements made at each step. After the pin showed deflection, the pressure in the test equipment was returned to half the design pressure, and the test cycle was repeated. Three levels of deflection were noted: **slight** (slight cocking bend), **moderate** (more pronounced bend starting to bow), and **great** (visible bow in the middle). An entire test consisted of achieving all three levels of deflection and then backing the pressure off each time.

Because the characterizations of the deflections were subjective, each observation was recorded only with the agreement of the two personnel from the contract laboratory and one representative from Southern Research Institute who were present during the entire testing program. It was not practical to measure precise deflections. Thus, the subjective scales were selected based on the observations of multiple observers.

### 3.0 RESULTS

Based on the verification tests conducted, the Pin-Tech relief valves were shown to operate leak tight during the non-vent mode and during repeated pin stressing. The direct-acting valves were shown to relieve within 5 percent of the design set pressure, but the actual relief pressures of the diaphragm-assisted relief valves were greater than 5 percent different of the design set pressures. Discussion of the test results follow. Using as an industry wide baseline some of the most widely used PRV designs, the leak tightness of the Pin-Tech design may provide greater emission reduction. A more detailed assessment is needed to verify the actual reductions compared to baseline technologies, and was not a focus of this verification test.

#### 3.1 LEAK TIGHTNESS RESULTS IN NON-VENT MODE

Results of the verification tests for leak tightness (non-vent mode) are summarized in Table 3-1. Because the test runs assessed screening concentrations at each incremental pressure, only the greatest screening concentration obtained is reported for each valve for pressures less than the set pressure of the valve. A valve is considered leak tight if it exhibits the characteristics of no detectable emissions (i.e. has a maximum screening concentration of less than 500 ppmv).

<b>Table 3-1. Leak Tightness Results (Non-Vent Mode)</b>				
<b>Device</b>	<b>Size, in.</b>	<b>Pressure set point</b>	<b>Number of Runs*</b>	<b>Highest reading, ppmv (below pressure set point)</b>
Pin-Tech #1 (direct-acting)	2	15 psig	4	25
Pin-Tech #2 (direct-acting)	24	8.6 psig	2	13
Pin-Tech #3 (diaphragm-assisted)	2	2 in. H <sub>2</sub> O (1.15 oz/in. <sup>2</sup> )	2	0**
Pin-Tech #4 (diaphragm-assisted)	24	3 in. H <sub>2</sub> O (1.73 oz/in. <sup>2</sup> )	2	1
* Each run for the lower-pressure devices consisted of 2 to 3 pressure increments. Each run for the higher-pressure devices consisted of 8 to 10 pressure increments.				
** Indicates that the readings from the valve were at or below the background levels of gas.				

All of the Pin-Tech devices were leak tight up to their set pressure. The greatest screening concentration recorded for any Pin-Tech device during the entire testing cycle was 25 ppmv, which is 5 percent of the screening concentration that defines “no detectable emissions” for PRVs in the non-venting mode. Thus, these test results verify that the Pin-Tech devices operated with “no detectable emissions” over the tank pressure cycles simulated.

Figure 3-1 shows the maximum screening concentrations measured for each test run for each of the Pin-Tech devices. Most screening concentrations are much less than the 25 ppmv maximum value obtained from the series of tests on the 2 in. direct-acting valve designed for 15 psig relief. All values shown demonstrate outstanding leak tightness over the range of pressures evaluated. Figure 3-2 shows screening concentrations for a typical test run on the Pin-Tech 2 in. direct-

acting PRV. Although a slight increase in the screening concentration at 12 psig might be viewed as abnormal behavior, in the context of the instrumentation and equipment leak regulation, there is little substantive difference between a 10 and 15 ppmv screening concentration.

**Figure 3-1. Pin-Tech Performance**

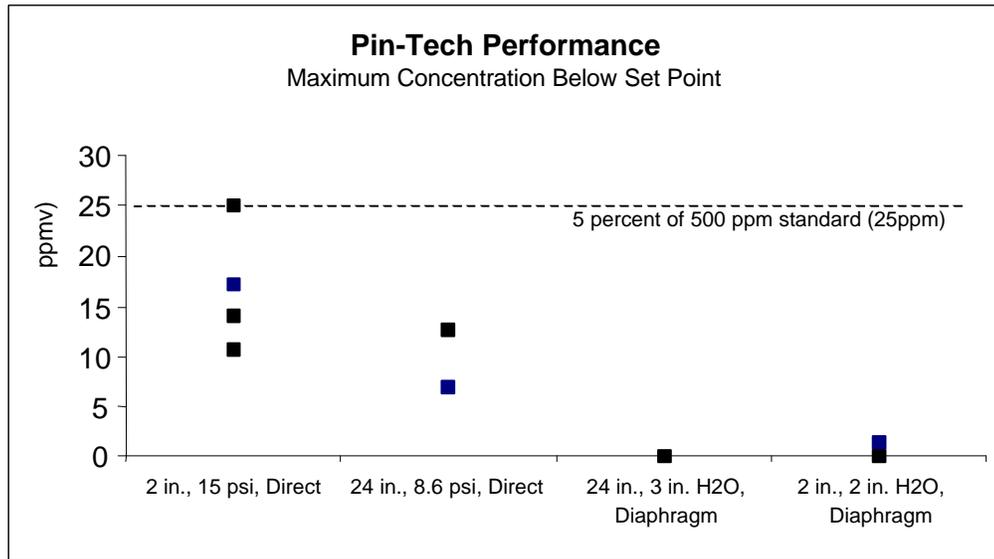

**Figure 3-2. Sample Screening Test Data**

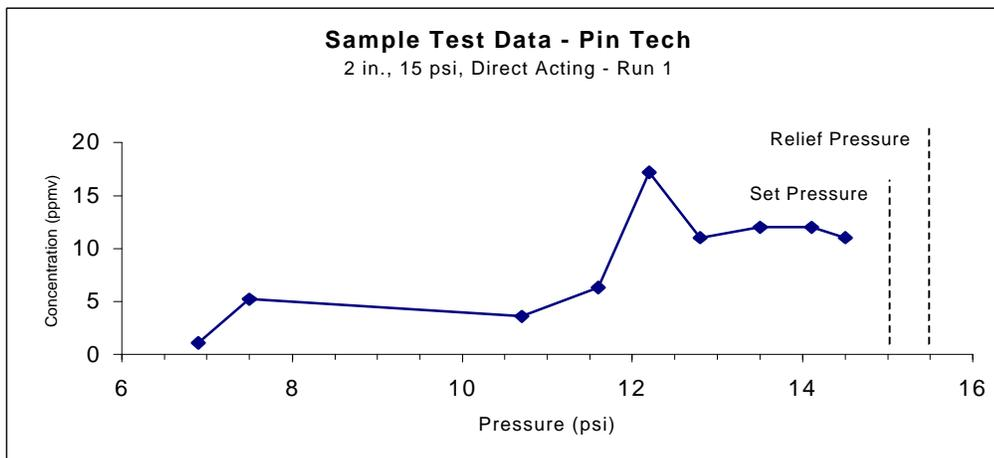

The evaluation of emission rates and reductions relative to the baseline or from conventional relief valves was to be included in this assessment. However, it was determined that to characterize PRV emissions for the baseline (conventional) technologies adequately, more representative tank pressure cycles were needed, longer-term testing would be required, and a large population of conventional PRVs would need to be tested. The screening verification was conducted for two conventional weight-loaded relief valves. In both cases, the screening concentrations for the conventional valves were greater than 1,000 ppmv before the design set pressure was achieved (Appendix A).

The physical operating mechanism for the Pin-Tech device is different from that for conventional valves (spring-loaded or weight-loaded). The Pin-Tech device relies upon the failure of a mechanical pin when exposed to a certain design stress. The size of the pin (length and diameter) and the mechanical properties of the material selected for fabrication of the pin (e.g., tensile strength) result in a pin that remains intact right up to the point of mechanical (tensile) failure.

Conventional valves (spring-loaded or weight-loaded) operate on the principle that relates elongation (e.g., of a spring) directly to the mass (or force) applied. A little force is going to compress the spring or lift the weight a little, the greater the force, the more the weight or spring will move. This is not the case with the Pin-Tech design; it will not release until the pin buckles. Accordingly, a conventional valve, especially at the lower pressure regions that were the subject of this study, would be expected to begin lifting as greater pressure is placed on the valve. Stated another way, the conventional valve is designed to relieve at the necessary rate at the set pressure. It is understandable that it would begin to unseat (partially if not wholly) before the set pressure was achieved to ensure that it would sufficiently open for proper and full relieving at the set pressure. This explanation is consistent with the observations from the testing and the results.

### 3.2 SET PRESSURE ACCURACY

The verification test results show that the Pin-Tech direct-acting devices operating in the 8 to 15 psig range performed within a 5 percent range of the design set point. (Table 3-2.) The results of testing of the diaphragm-assisted PRVs were not within this percent range. Because these pressure settings were on the low end, the pressure regulator did not have the sensitivity to allow the pressurized gas to flow into the receiving tank at a slow enough rate to observe the actual pressure at which the valve relieved. For this reason, the relief pressures for the diaphragm assisted Pin-Tech devices are given as ranges. The lower number in the range represents the average value where the Pin-Tech was still tight. The greater number is the observed relief pressure. The actual relief pressure lies between those two numbers. The percent differences between actual relief pressure and design set pressure for these two units were 195 percent for the 2 in. model and 40 percent for the 24 in. model.

**Table 3-2. Pressure Relief for Pin-Tech Devices**

Pin-Tech Device	Design Set Pressure	Actual Relief Pressure (averaged)	Pressure Difference	Average Difference (%)**	Number of Runs
2 in. direct-acting	15 psig	15.7 psig	+ 0.7 psig	4.7	4
24 in. direct-acting	8.6 psig	8.8 psig	+ 0.2 psig	2.3	3
2 in. diaphragm-assisted	2 in. H <sub>2</sub> O (1.15 oz/in. <sup>2</sup> )	4.8 to 5.9* in. H <sub>2</sub> O (2.7 to 3.4 oz/in. <sup>2</sup> )	+ 2.8 to + 3.9 in. H <sub>2</sub> O (+ 1.65 to +2.25 oz/in. <sup>2</sup> )	138 to 195	3
24 in. diaphragm-assisted	3 in. H <sub>2</sub> O (1.73 oz/in. <sup>2</sup> )	3.0 to 4.2* in. H <sub>2</sub> O (1.7 to 2.4oz/in. <sup>2</sup> )	0 to + 1.2 in. H <sub>2</sub> O (0 to + 0.67 oz/in. <sup>2</sup> )	0 to 40	5

\* Lower number is average value where Pin-Tech was still tight. Larger number is the observed relief pressure.  
 \*\*100\* [(actual relief pressure – design set pressure)/design set pressure].

Another possible explanation for the lack of conformance with the design goal of 5 percent for the lower-pressure diaphragm-assisted valves is the pins used for the equipment. Factory-milled pins were not prepared for this testing program to meet the test schedule. The pins arrived as long strands of wire that were cut, using standard wire cutters, to approximate the proper length by on-site Protectoseal personnel. It is possible that the pins could have been cut to the wrong length, affecting the relief pressure. Also, the wire cutters crimped the ends of the pin, which may have had some effect on the relief pressure. If the wire had been milled, the ends of the wire would have been square and better fitted to the mounting hardware on the relief valve. Because the diaphragm mechanism magnifies the force on the pin, a small error in any of these instances could have a significant effect on the relief pressure.

### 3.3 REPEATED PIN STRESS IMPACTS

The leak tightness of the Pin-Tech device was examined when the pin was subjected to repeated pressure swings. To perform this evaluation, the pressure was varied to deflect the pin visibly. The pin was stressed to three visible levels of deflection (Figure 3-3), with screening values being made at each level of deflection. The pressure was backed off to allow the pin to straighten and then the pressure was increased to the next level of deflection. This was done four times, and the screening concentrations from the four runs for the repeated pin stress evaluation are shown against the pressure used in the test equipment (Figure 3-3). All of the runs were done on the 2 in. direct-acting device. For simplicity, the pressure is shown as a percentage of the 15 psig design set pressure. The description of the pin stressing is shown for perspective. A cursory observation of the results might indicate that there was significant variability in the screening concentrations during the pin stress evaluations. At no time, however, did the screening concentration exceed 20 ppmv, even after repeated stressing. The actual screening concentrations are much less than the 500 ppmv definition of “detectable emissions.” The variability in the screening concentrations is consistent with the variability of screening concentrations determined

from previous equipment leak studies for the chemical and petroleum industries. Further, at this screening concentration level, the differences between 10 and 15 ppmv are not statistically or instrumentally significant (i.e., to meet the 500 ppmv limit, the difference between 10 and 15 ppmv is insignificant).

**Figure 3-3. Pin Stressing for 2 in. Direct Acting Pin-Tech  
(4 separate runs shown)**

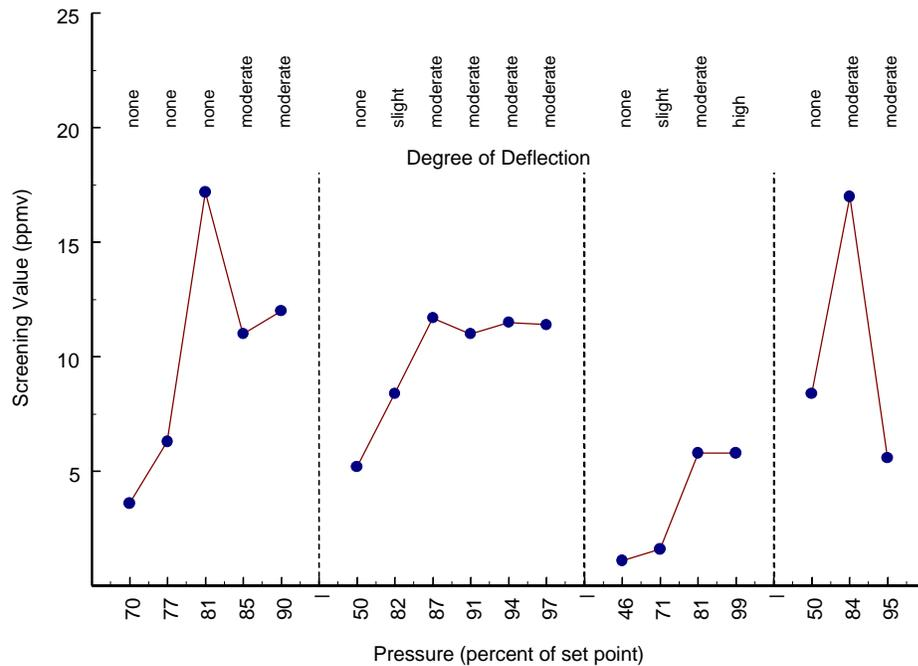

**4.0 SAMPLING AND QC/QA PROCEDURES**

Specific quality control and quality assurance (QC/QA) procedures were adhered to during this test program to help ensure the collection of useful and valid data, and the development of supportable conclusions for each verification parameter. The QC/QA goals, checks, and procedures are integral to the methods and test equipment used, and represent a vital part of the overall verification process.

Key elements of this verification test, from a sampling and analytical perspective, are (1) the testing methods and equipment used to determine screening concentrations, and (2) the equipment used to measure pressure, particularly the pressure at which a valve opens or relieves. For each of the three verification parameters characterized in this report, Table 4-1 lists the critical measurements collected, the performance or data quality goals set for each measurement, and the minimum number of individual tests planned. These represent important indicators of data quality for each verification parameter characterized, and based on calibration and other data collected, are quantified later in this section. A goal of this section is to allow users to place the verification results reported for each Pin-Tech valve into context based on values presented for the data quality indicators listed in Table 4-1. Section 4.1 addresses methane concentration data quality indicators, while Sections 4.2 and 4.3 address pressure measurement error and the number of tests completed (completeness), respectively.

**Table 4-1. Overview of Important Data Quality Indicators**

Verification Parameter	Critical Measurements		Minimum Number of Tests Planned
	Measured Value	Data Quality Indicator & Indicator Goal	
Leak Tightness	Methane Concentration *	Instrument Response Time: 30 Seconds Calibration Precision: 10% Calibration Drift: 10%	2 per valve tested
Set-Point Accuracy	Pressure at Relief	0.5% error at the relief pressure	2 per valve tested
Repeated Pin Stress	Pressure at Relief	0.5% error at the relief pressure	2

\* As measured at the leak interface between the PRV and the Tank.

**4.1 CONCENTRATION MEASUREMENT PERFORMANCE OF THE AUTOFIM II**

Method 21 prescribes performance criteria to be met by the hydrocarbon analyzer used to obtain screening concentrations (Table 4-2). The monitoring instrument selected for this program must meet these criteria.

**Table 4-2. Performance Criteria for Method 21 Measuring Instruments**

<b>Performance Parameter</b>	<b>Acceptable Maximum</b>
Response Time	30 seconds
Calibration Precision	10 percent of calibration gas value
Calibration Drift	10 percent

QA checks include a response time test, a calibration precision test, and frequent drift tests. The Autofim II analyzer met the Method 21 performance requirements for response time, calibration precision, and calibration drift (Table 4-3).

- The response time test measures the ability of the analyzer to measure the concentration of the specified compound (in this case, a methane in air calibration gas) within a preset amount of time. A minimum of 90 percent of the actual gas concentration must be detected within less than 30 seconds to satisfy Method 21 requirements. The analyzer probe was exposed to a bag of gas with a known concentration (524 ppmv of methane in air). Because the instrument response was rapid, the concentration values displayed on the instrument changed quickly upon initial exposure to the calibration gas. This made it difficult to read concentration values initially, and made it impossible to identify the time at which exactly 90 percent of the concentration was recorded. Thus, the measured response times reported in Table 4-3 correspond to the first concentration values above 90 percent that could be clearly read and recorded. These concentration values, shown in Table 4-3, were always well above 90 percent of the calibration gas concentration. This procedure was repeated three times. At a maximum of 9 seconds, the Autofim's response time was substantially faster than required.
- The calibration precision test determines if the analyzer can repeatedly measure a known concentration (524 ppmv methane in air). The probe was exposed to the known concentration and the final value recorded. The probe was then exposed to zero concentration gas to clear the unit and the precision test was repeated. A total of three repetitions were conducted. At a maximum calibration precision of 3.2 percent, the Autofim was well within the 10 percent acceptance criterion. Based on these replicate measurements, the standard deviation in the measured concentrations was 3.2 ppmv. The standard deviation relative to the average concentration measured was calculated to be 0.6 percent.
- The drift test is not part of Method 21, but is included as good scientific practice to ensure that the data remain accurate over the entire sampling period. A 10 percent acceptance criterion is chosen. Drift tests were performed by withdrawing a gas of known concentration (524 ppmv methane in air) and recording the final concentration (after approximately 15 seconds). Drift tests were made after each test run. At the post-test check for 8/4/99, a percent error of -10.3 was obtained, resulting from a nearly empty bag of calibration gas. The runs made this day were repeated 8/5/99. After

refilling the bag with calibration gas and re-performing the drift test, it was within 10 percent. In addition, if the percent error was approaching the maximum 10 percent, an additional drift test was performed.

<b>Table 4-3. QA Records and Checks</b>					
<b>Response Time Test: 8/4/99; 1:35pm, analyst: B. Phillips</b>					
Test Number	Calibration Concentration (ppmv)	Concentration When Response Time Was Recorded * (ppmv)	Response Time (sec.)	< 30 sec.?	
1	524	512	4	Yes	
2	524	502	9	Yes	
3	524	521	5	Yes	
Average	524	512	6	Yes	
<b>Calibration Precision Test: 8/4/99;1:50pm, analyst: B. Phillips</b>					
Test Number	Calibration Concentration (ppmv)	Instrument Meter Reading (ppmv)	Difference (ppmv)	Difference (%)	Passed?
1	524	536	12	2.3	Yes
2	524	541	17	3.2	Yes
3	524	535	11	2.1	Yes
Average	524	537	13	2.5	Yes

\* To execute the response time determination properly, this concentration value must be at least 90% of the calibration concentration. (continued)

**Table 4-3. QA Records and Checks (continued)**

<b>Drift Test</b>					
<b>Instrument ID: Autofim II</b>					
<b>Analyst name: B. Phillips</b>					
<b>Nominal Gas Concentration: 524 ppmv</b>					
Run Number	Device	Date	Time	Concentration (ppmv)	Difference (%)
1	2 in. Pin-Tech Dir. Act.	8/4	1400	536	2.3
2	2 in. Pin-Tech Dir. Act.	8/4	1600	531	1.3
3	2 in. Pin-Tech Dir. Act.	8/4	1730	470	-10.3*
4	2 in. Pin-Tech Dir. Act.	8/5	850	529	0.1
5	24 in. Pin-Tech Dir. Act.	8/5	1005	526	0.4
6	24 in. Pin-Tech Dir. Act.	8/5	1030	474	-9.5
7	24 in. Pin-Tech Dia. Ass't.	8/5	1045	494	-5.7
8	24 in. Pin-Tech Dia. Ass't.	8/5	1105	478	-8.8
9	2 in. Pin-Tech Dia. Ass't.	8/5	1430	538	2.7
10	2 in. Conventional	8/5	1530	550	5.0
11	12 in. Conventional	8/5	1605	537	2.5

\*10.3 percent is out of range. This run was repeated on 8/5/99 with less drift. For 8/5/99, the daytime high temperature was 93° F, and barometric pressure was 29.95 mm Hg.

The test plan noted that a hydrocarbon analyzer would be used for the test program. In the plan a Foxboro OVA-128 was initially specified, but was abandoned because an electrical short prevented proper operation. The Autofim II meets the performance criteria, and was used instead of the Foxboro unit.

**4.2 PRESSURE MEASUREMENT PERFORMANCE**

Two different digital pressure gauges were used to monitor pressure in the tank upon which each valve was placed for testing. A gauge with a range of 0 to 30 psig was used to monitor pressure during tests on the direct acting valves (the higher set pressure valves), while a gauge with a range of 0 to 20 oz/in.<sup>2</sup> was used to monitor pressure during the diaphragm-assisted valve tests (lower set pressure). The data quality objective established for pressure measurement was to

collect pressure readings that contained no more error than 0.5 percent of the pressure recorded at the point of valve relief.

The two pressure gauges were provided by Southeastern Valve, Inc., and each was calibrated prior to testing against a NIST traceable standard. Calibration of the 0 to 30 psig gauge was performed on 7/8/99 while calibration of the 0 to 20 oz/in.<sup>2</sup> gauge was performed on 8/10/99. A multi-point calibration was performed on each gauge over its entire range, and a plot of pressure gauge error, the difference between the gauge pressure and NIST standard pressure, is shown in Figure 4-1 for the 0 to 30 psig gauge. Attempts to determine trends in these results using linear regression and polynomial curve fitting techniques failed to identify clear performance tendencies, so the data points are simply connected with straight lines in the figure.

Using actual relief pressures measured for each valve (see Table 3-2), this plot was used to select an estimated error for the pressure value measured at the point each of the higher pressure direct-acting valves relieved. Dividing this error by the actual relief pressure measured yields an estimate of the percent error experienced for each valve relief test. For the direct acting valves tested, estimated pressure measurement errors ranged from 0.54 to 0.45 percent; close to the data quality goal of 0.5 percent. Calibration results for the 0 to 20 oz/in.<sup>2</sup> pressure gauge used on the diaphragm-assisted valves could not be used to specify test-specific pressure measurement accuracy values. A five-point calibration was done, but more calibration points at the low end of the meters range would be needed to reliably determine test-specific accuracies. The average accuracy of the gauge over the instrument's range is used to assess pressure measurement accuracy for the pressure tests conducted on diaphragm-assisted valves. The value is 1.15 percent, which is about 0.6 percent higher than the original goal.

Both instrumental and human factors can impact the overall error in the pressure measurements collected, and methods chosen for interpreting the calibration plots above can impact the calculation of percent error values. As such, the estimated errors discussed above are intended to provide an approximation of pressure measurement error, and should be used accordingly.

**Figure 4-1. Calibration Results for the 0 to 30 psig Pressure Gauge**

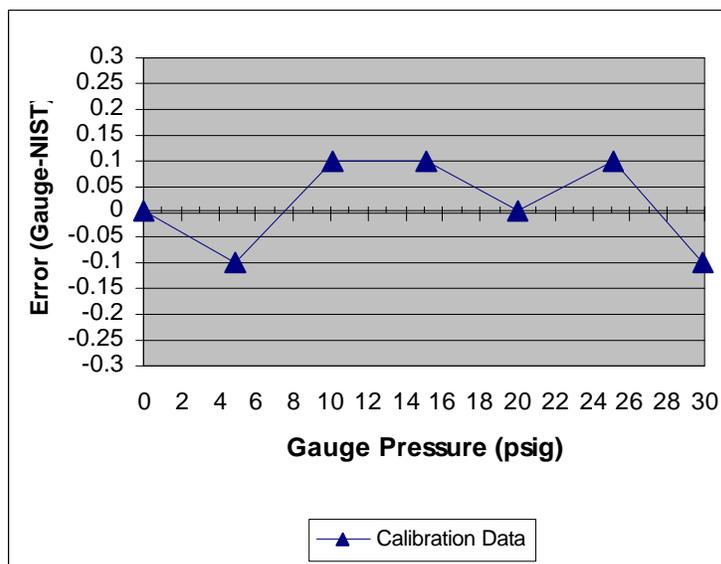

**4.3 TEST COMPLETENESS**

Four different Pin-Tech devices were tested representing the range of such devices available. All planned tests were successfully completed, with at least two runs successfully completed for each test (Table 4-4).

<b>Table 4-4. Test Completeness (runs)</b>					
<b>Number Completed</b>					
<b>Test</b>	<b>Minimum Number of Tests Planned</b>	<b>2 in. Direct Acting</b>	<b>24 in. Direct Acting</b>	<b>2 in. Diaphragm Assisted</b>	<b>24 in. Diaphragm Assisted</b>
Leak Tightness	2	4	2	2	2
Set Point Accuracy	2	4	3	3	5
Repeated Pin Stress Impact	2	4	---	---	---

**4.4 TEST GAS CERTIFICATION**

All gases used to perform the QC checks were certified by the vendor, Air Products and Chemicals, Inc. The gases used in this test include the calibration gas (524 ppmv methane in air  $\pm$  2 percent), the zero concentration gas (< 10 ppmv hydrocarbons), and the gas placed under pressure in the receiving tank (1.46 percent methane in nitrogen). Copies of these certifications from the vendor are on file.

## 5.0 REFERENCES

40 CFR Part 60, Subpart GGG. Standards of Performance for Equipment Leaks of VOC in Petroleum Refineries; Title 40 of the Code of Federal Regulations Part 60, Subpart GGG, 1999.

40 CFR Part 63, Subpart H. National Emission Standards for Organic Hazardous Air Pollutants for Equipment Leaks, Title 40 of the Code of Federal Regulations Part 63, Subpart H, July 1, 1994.

GRI 1997. *Production Tank Emissions Model (E&P TANK Version 1.0), Report and User's Manual. A Program for Estimating Emissions from Hydrocarbon Production Tanks.* Software No. 4660. American Petroleum Institute and Gas Research Institute. (Prepared by DB Robinson Research Ltd.), October 1997.

Method 21 - Determination of Volatile Organic Compounds Leaks. Code of Federal Regulations, Title 40, Part 60, Appendix A, February 9, 1993.

Radian 1992. Letter to James Durham, EPA-OAQPS, from Marco Zarate, Radian Corporation. Transmittal of Section 114 storage tank data summary report for petroleum refineries, March 3, 1992 (EPA-OAQPS Docket No. A-93-48-II-B-1).

SRI 1999. *Testing and Quality Assurance QA Plan for The Protectoseal Company's Pin-Tech Pressure Relief Valves.* SRI/USEPA-GHG-QAP-06, Greenhouse Gas Technology Verification Center, Southern Research Institute, Research Triangle Park, NC, July 1999.

**APPENDIX A**

**Leak Tightness Data for Conventional PRVs**

**TABLE A-1. Leak Tightness Data for Conventional PRVs**

Device	Size (in.)	Pressure set point (oz/in. <sup>2</sup> )	Number of Runs	Highest reading ppmv (below pressure set point)
Conventional PRV #1	2	1	2	>1000 (0.75 oz/in. <sup>2</sup> )
Conventional PRV #2	12	1	2	>1000 (0.5 oz/in. <sup>2</sup> )