

US EPA ARCHIVE DOCUMENT

Test and Quality Assurance Plan

Electric Power and Heat Production Using Renewable Biogas at Patterson Farms

Prepared by:



Greenhouse Gas Technology Center

Operated by

Southern Research Institute



Under a Cooperative Agreement With
U.S. Environmental Protection Agency

and



Under Agreement With
New York State Energy Research and Development Authority

ETV ✓ ETV ✓ ETV ✓

EPA REVIEW NOTICE

This report has been peer and administratively reviewed by the U.S. Environmental Protection Agency, and approved for publication. Mention of trade names or commercial products does not constitute endorsement or recommendation for use.

Greenhouse Gas Technology Center

A U.S. EPA Sponsored Environmental Technology Verification (ETV) Organization



Test and Quality Assurance Plan

Electric Power and Heat Production Using Renewable Biogas at Patterson Farms

Prepared by:
Greenhouse Gas Technology Center
Southern Research Institute
PO Box 13825
Research Triangle Park, NC 27709 USA
Telephone: 919/806-3456

Reviewed by:
New York State Energy Research and Development Authority
The Patterson Farm
U.S. EPA Office of Research and Development QA Team

indicates comments are integrated into TQAP

(this page intentionally left blank)



Greenhouse Gas Technology Center
 A U.S. EPA Sponsored Environmental Technology Verification (ETV) Organization

**Electric Power and Heat Production Using Renewable Biogas
 at Patterson Farms**

This Test and Quality Assurance Plan has been reviewed and approved by the Greenhouse Gas Technology Center Project Manager and Center Director, the U.S. EPA APPCD Project Officer, and the U.S. EPA APPCD Quality Assurance Manager.

Signed by Richard Adamson
 Richard Adamson
 Director
 Greenhouse Gas Technology Center
 Southern Research Institute

11/07
 Date

Signed by David Kirchgessner
 David Kirchgessner
 APPCD Project Officer
 U.S. EPA

11/20/07
 Date

Signed by William Chatterton
 William Chatterton
 Project Manager
 Greenhouse Gas Technology Center
 Southern Research Institute

11/07
 Date

Signed by Robert Wright
 Robert Wright
 APPCD Quality Assurance Manager
 U.S. EPA

11/20/07
 Date

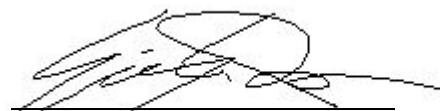
 Eric Ringler
 Quality Assurance Manager
 Greenhouse Gas Technology Center
 Southern Research Institute

04/07
 Date

TQAP Final: April 2007

TABLE OF CONTENTS

	<u>Page</u>
APPENDICES	ii
LIST OF FIGURES	ii
LIST OF TABLES	ii
DISTRIBUTION LIST	iii
1.0 INTRODUCTION	1-1
1.1 BACKGROUND	1-1
1.2 PATTERSON FARMS DG/CHP SYSTEM DESCRIPTION	1-2
1.3 ORGANIZATION AND RESPONSIBILITIES	1-3
1.4 SCHEDULE	1-5
2.0 VERIFICATION APPROACH.....	2-1
2.1 SYSTEM BOUNDARY	2-1
2.2 VERIFICATION PARAMETERS	2-2
2.2.1 Electrical Performance (GVP §2.0)	2-3
2.2.2 Electrical Efficiency (GVP §3.0)	2-3
2.2.3 CHP Thermal Performance (GVP §4.0)	2-4
2.2.4 Emissions Performance (GVP §5.0)	2-4
2.2.5 Field Test Procedures and Site Specific Instrumentation.....	2-5
2.2.6 Estimated NO _x and CO ₂ Emission Offsets	2-8
3.0 DATA QUALITY OBJECTIVES.....	3-9
4.0 DATA ACQUISITION, VALIDATION, AND REPORTING.....	4-1
4.1 DATA ACQUISITION AND DOCUMENTATION	4-1
4.1.1 Corrective Action and Assessment Reports	4-1
4.2 DATA REVIEW, VALIDATION, AND VERIFICATION.....	4-2
4.3 INSPECTION/ACCEPTANCE OF SUPPLIES, CONSUMABLES, AND SERVICES.....	4-2
4.4 DATA QUALITY OBJECTIVES RECONCILIATION.....	4-3
4.5 ASSESSMENTS AND RESPONSE ACTIONS	4-3
4.5.1 Project Reviews	4-3
4.5.2 Test/QA Plan Implementation Assessment.....	4-4
4.5.3 Audit of Data Quality.....	4-4
4.6 VERIFICATION REPORT AND STATEMENT	4-4
4.7 TRAINING AND QUALIFICATIONS	4-5
4.8 HEALTH AND SAFETY REQUIREMENTS	4-5
5.0 REFERENCES	5-1

APPENDICES

APPENDIX A Electric Power System Emissions Reduction Estimates **Page** A-1

LIST OF FIGURES

Figure 1-1. Patterson Farms in Auburn, New York 1-3
Figure 1-2. Project Organization..... 1-4
Figure 2-1. The Patterson Farm DG/CHP System Boundary Diagram 2-2
Figure 2-2. Position of Test Instrumentation for SUT Electrical System 2-7
Figure 2-3. Location of Test Instrumentation for SUT Thermal System..... 2-7
Figure B-1. Example Aggregated Emissions Introductory Screen B-2
Figure B-2. Example EPS Emission Rates for 2000..... B-2
Figure B-3. Nationwide Emission Rates..... B-3

LIST OF TABLES

Table 2-1. Site Specific Instrumentation for Patterson Farms DG/CHP System Verification..... 2-6
Table B-1. Example Fuel Cell Emissions Offsets Estimates B-3
Table B-2. Example CHP Emissions Offsets Estimates B-4

US EPA ARCHIVE DOCUMENT

DISTRIBUTION LIST

New York State Energy Research and Development Authority

Richard Drake

James Foster

Ed Kear

Patterson Farms

Connie Patterson

John Patterson

U.S. EPA – Office of Research and Development

David Kirchgessner

Robert Wright

Southern Research Institute (GHG Center)

Richard Adamson

William Chatterton

Eric Ringler

1.0 INTRODUCTION

1.1 BACKGROUND

The U.S. Environmental Protection Agency's Office of Research and Development (EPA-ORD) operates the Environmental Technology Verification (ETV) program to facilitate the deployment of innovative technologies through performance verification and information dissemination. The goal of the ETV program is to further environmental protection by substantially accelerating the acceptance and use of improved and innovative environmental technologies. Congress funds ETV in response to the belief that there are many viable environmental technologies that are not being used for the lack of credible third-party performance data. With performance data developed under this program, technology buyers, financiers, and permittees in the United States and abroad will be better equipped to make informed decisions regarding environmental technology purchase and use.

The Greenhouse Gas Technology Center (GHG Center) is one of six verification organizations operating under the ETV program. The GHG Center is managed by EPA's partner verification organization, Southern Research Institute (Southern), which conducts verification testing of promising GHG mitigation and monitoring technologies. The GHG Center's verification process consists of developing verification protocols, conducting field tests, collecting and interpreting field and other data, obtaining independent peer-review input, and reporting findings. Performance evaluations are conducted according to externally reviewed verification Test and Quality Assurance Plans (TQAPs) and established protocols for quality assurance (QA).

The GHG Center is guided by volunteer groups of stakeholders. The GHG Center's Executive Stakeholder Group consists of national and international experts in the areas of climate science and environmental policy, technology, and regulation. It also includes industry trade organizations, environmental technology finance groups, governmental organizations, and other interested groups. The GHG Center's activities are also guided by industry specific stakeholders who provide guidance on the verification testing strategy related to their area of expertise and peer-review key documents prepared by the GHG Center.

In recent years, a primary area of interest to GHG Center stakeholders has been distributed electrical power generation systems. Distributed generation (DG) refers to equipment, typically ranging from 5 to 1,000 kilowatts (kW) that provide electric power at a site closer to customers than central station generation. A DG unit can be connected directly to the customer or to a utility's transmission and distribution system. Examples of technologies available for DG includes internal combustion engine generators, photovoltaics, wind turbines, fuel cells, and microturbines. DG technologies provide customers one or more of the following main services: standby generation, peak shaving generation, baseload generation, or cogeneration. DG systems that utilize renewable energy sources can provide even greater environmental and economic benefits.

Since 2002, the GHG Center and the New York State Energy Research and Development Authority (NYSERDA) have collaborated and shared the cost of verifying several new DG technologies throughout the state of New York under NYSERDA-sponsored programs. The verification described in this document will evaluate the performance of one such DG system: a Caterpillar Model G379 internal combustion engine and generator - combined heat and power (CHP) system manufactured by Martin Machinery and fueled with biogas generated at a dairy farm. The system is owned and operated by

Patterson Farms near Auburn, New York. The GHG Center will be evaluating the performance of this system in collaboration with NYSERDA.

In September 2005 the GHG Center published the Generic Verification Protocol (GVP) for Distributed Generation and Combined Heat and Power Field Testing [1]. The GVP is designed specifically for microturbine and IC engine based CHP systems. This document is the site specific TQAP for this performance verification. This TQAP does not repeat the rationale for the selection of verification parameters, the verification approach, data quality objectives (DQOs), and Quality Assurance/Quality Control (QA/QC) procedures specified in the GVP. Instead, this plan includes descriptions of the Patterson Farms DG/CHP system, its integration at the farm, site specific measurements and instrumentation, and site specific exceptions to the GVP. This performance verification will include evaluation of the following parameters:

- electrical performance
- electrical efficiency
- CHP performance
- atmospheric emissions
- NO_x and CO₂ emission offsets

This TQAP has been reviewed by NYSERDA, Patterson Farms representatives, and the EPA QA team. As evidenced by the signature sheet at the front of this document, it meets the requirements of the GHG Center's Quality Management Plan (QMP) and thereby satisfies the ETV QMP requirements for environmental testing. This TQAP has been prepared to guide implementation of the test and to document planned test operations. Once testing is completed, the GHG Center will prepare a Technology Verification Report and Verification Statement, which will first be reviewed by NYSERDA and Patterson Farms. Once all comments are addressed, the report will be reviewed by the EPA QA team. Once completed, the GHG Center Director and the EPA Laboratory Director will sign the Verification Statement, and the final Report will be posted on the Web sites maintained by the GHG Center (www.sri-ntp.com) and ETV program (www.epa.gov/etv).

1.2 PATTERSON FARMS DG/CHP SYSTEM DESCRIPTION

The Patterson Farm, shown in Figure 1-1, is a dairy farm in upstate New York housing approximately 1,725 cows and heifers. Farm operations generate approximately 50,000 gallons per day of manure and process water. This waste is collected and pumped to a solids removal system where solids are separated and composted. Composted solids are later used as animal bedding, and separated liquids are pumped to a complete mix anaerobic digester designed by RCM Digesters of Berkeley, California. The digester's dimensions are approximately 135 by 125 by 16 feet deep with a total waste capacity of approximately 270,000 cubic feet.

In addition to farm waste, operators also feed cheese whey waste generated off-site into the digester. The anaerobic digestion system produces biogas that is typically about 60 percent methane and has an average lower heating value (LHV) of approximately 600 Btu/cf. Approximately 4,800 cfh of the biogas is used to fuel an on-site DG/CHP system, and the remainder is flared.

The DG/CHP system consists of a Caterpillar Model 379, 200 kW engine-generator set with integrated heat recovery capability.



Figure 1-1. Patterson Farms in Auburn, New York

Prior to being used as fuel, the wet biogas is passed through two Filtration Systems, Inc. Model G82308 water filtration units arranged in series to remove moisture from the gas. Dry biogas is then metered and delivered to the engine. During normal farm operations, the engine generates nominal 187 kW power at an electrical efficiency of approximately 22 percent. The facility is equipped with net power metering so that excess power generated on-site can be exported to the grid and credited. The engine is equipped with a heat recovery system that recovers approximately 800 to 1,400 thousand Btu per hour (MBtu/hr) during full load operations and also cools the engine. Water with trace amounts of rust inhibitor is used as the heat transfer fluid. Of the heat recovered, approximately 200 to 500 MBtu/hr is used to warm the digester during summer months and approximately 400 to 800 MBtu/hr during colder months. The remaining excess heat is dissipated through a radiator. The farm has plans to expanded engine heat use by supplying hot water to the milking parlor in the future.

1.3 ORGANIZATION AND RESPONSIBILITIES

Figure 1-2 presents the project organization chart. The following section discusses functions, responsibilities, and lines of communications for the verification test participants.

Southern's GHG Center has overall responsibility for planning and ensuring the successful implementation of this verification test. The GHG Center will ensure that effective coordination occurs, schedules are developed and adhered to, effective planning occurs, and high-quality independent testing and reporting occur.

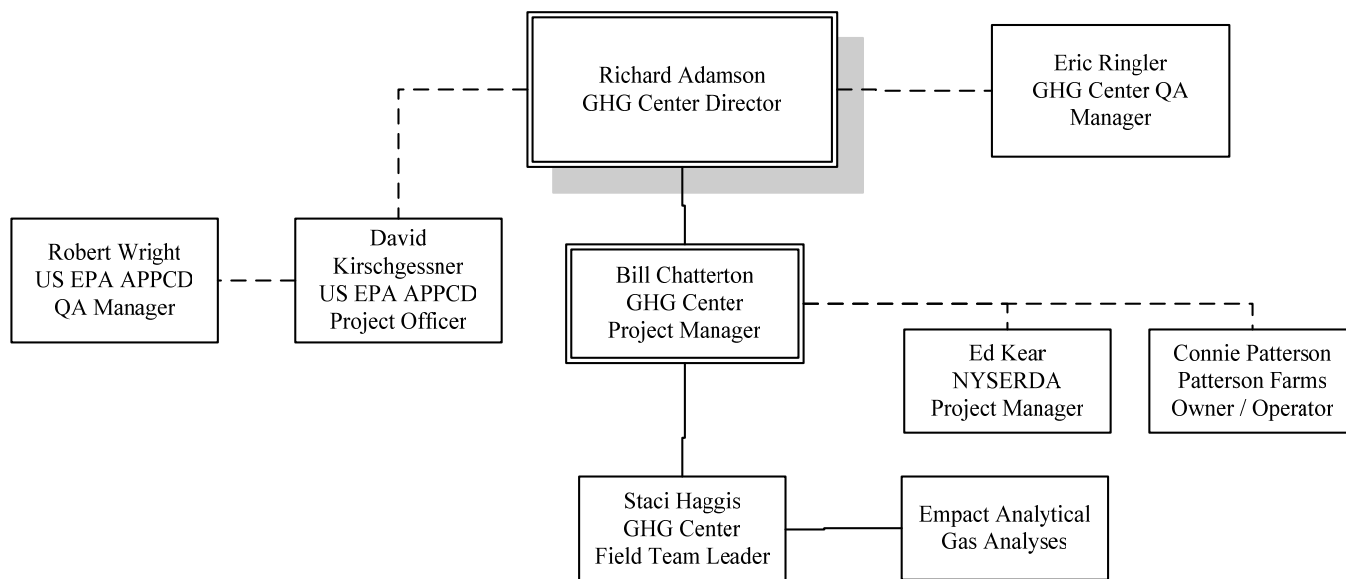

Figure 1-2. Project Organization

Richard Adamson is the GHG Center Director. He will ensure the staff and resources are available to complete this verification as defined in this TQAP. He will review the TQAP and Report to ensure they are consistent with ETV operating principles. He will oversee the activities of the GHG Center staff, and provide management support where needed. Mr. Adamson will sign the Verification Statement, along with the EPA-ORD Laboratory Director.

Bill Chatterton will serve as the Project Manager for the GHG Center. His responsibilities include:

- drafting the TQAP and verification report;
- overseeing the field team leader’s data collection activities, and
- ensuring that data quality objectives are met prior to completion of testing.

The project manager will have full authority to suspend testing should a situation arise that could affect the health or safety of any personnel. He will also have the authority to suspend testing if the data quality indicator goals are not being met. He may resume testing when problems are resolved in both cases. He will be responsible for maintaining communication with Patterson Farms, NYSERDA, and EPA. He also oversees and manages subcontractor activities and submittals.

Staci Haggis will serve as the Field Team Leader. Ms. Haggis will provide field support for activities related to all measurements and data collected. She will install and operate the measurement instruments, supervise and document activities conducted by the emissions testing contractor, collect gas samples and coordinate sample analysis with the laboratory, and ensure that QA/QC procedures outlined in this TQAP are followed, including QA requirements for subcontractors (in this case, the analytical laboratory). She will submit all results to the Project Manager, such that it can be determined that the DQOs are met.

Southern’s QA Manager, Eric Ringler, is responsible for ensuring that all verification tests are performed in compliance with the QA requirements of the GHG Center QMP, the GVP, and this TQAP. He has reviewed and is familiar with each of these documents. He will also review the verification test results

and ensure that applicable internal assessments are conducted as described in these documents. He will reconcile the DQOs at the conclusion of testing and will conduct or supervise an audit of data quality. He is also responsible for review and validation of subcontractor activities, review of subcontractor generated data, and confirmation that subcontractor QA/QC requirements are met. Mr. Ringler will report all internal reviews, DQO reconciliation, the audit of data quality, and any corrective action results directly to the GHG Center Director, who will provide copies to the project manager for corrective action as applicable and citation in the final verification report. He will review and approve the final verification report and statement. He is administratively independent from the GHG Center Director and maintains stop work authority.

Connie Patterson of Patterson Farms and Ed Kear of NYSERDA will serve as the primary contact persons for the verification team. They will provide technical assistance, assist in the installation of measurement instruments, and coordinate operation of the cogeneration system at the test site. They will ensure the units are available and accessible to the GHG Center for the duration of the test. They will also review the TQAP and Reports and provide written comments.

EPA-ORD will provide oversight and QA support for this verification. The APPCD Project Officer, Dr. David Kirchgessner, is responsible for obtaining final approval of the TQAP and Report. The APPCD QA Manager reviews and approves the TQAP and the final Report to ensure they meet the GHG Center QMP requirements and represent sound scientific practices.

1.4 SCHEDULE

The tentative schedule of activities for testing is:

Verification TQAP Development

GHG Center Internal Draft Development	October, 2006
NYSERDA and Patterson Farms Review/Revision	December, 2006
EPA Review/Revision	January, 2007
Final TQAP Posted	April, 2007

Verification Testing and Analysis

Measurement Instrument Installation/Shakedown	May, 2007
Field Testing	May, 2007
Data Validation and Analysis	May, 2007

Verification Report Development

GHG Center Internal Draft Development	June, 2007
NYSERDA and Patterson Farms Review/Revision	July, 2007
EPA Review/Revision	July, 2007
Final Report Posted	August, 2007

2.0 VERIFICATION APPROACH

This performance verification will be conducted following the guidelines and procedures specified in the GVP. This TQAP includes site-specific information including the following:

- Definition of the system under test (SUT) boundary for this verification - §2.1,
- Summary of the Patterson Farms verification parameters and references to the applicable measurements, procedures, and calculations from the GVP - §2.2, and
- Site specific instrumentation - §2.3.

Following the GVP, the verification will include evaluation of the Patterson Farms system performance over a series of controlled test periods. The GVP specifies controlled tests be conducted at three different loads including 100, 75, and 50 percent of capacity. Following these specifications, the electrical load on the generator will be modulated such that tests will be conducted at nominal power outputs of 200, 150, and 100 kW. Procedures related to the load tests are summarized in §2.2.6 of this TQAP and detailed in §7.1 through §7.4 of the GVP. In addition to the controlled test periods, the GHG Center will collect sufficient data to characterize the system's performance over normal facility operations. This will include up to 1 week of continuous monitoring of fuel consumption, power generation, power quality, and heat recovery rates.

2.1 SYSTEM BOUNDARY

The Patterson Farms verification will be limited to the performance of the system under test (SUT) within a defined system boundary. Figure 2-1 illustrates the SUT boundary for this verification.

The figure indicates two distinct boundaries. The device under test (DUT) or product boundary includes the Caterpillar engine and generator set, and the heat recovery system and all of its internal components. The SUT includes the DUT as well as parasitic loads present in this application: the water circulation pump, the gas filtration system, and the radiator fan motor. Following the GVP, this verification will incorporate the system boundary into the performance evaluation. The parasitic loads will be verified to determine the overall system electrical and thermal efficiency for this installation.

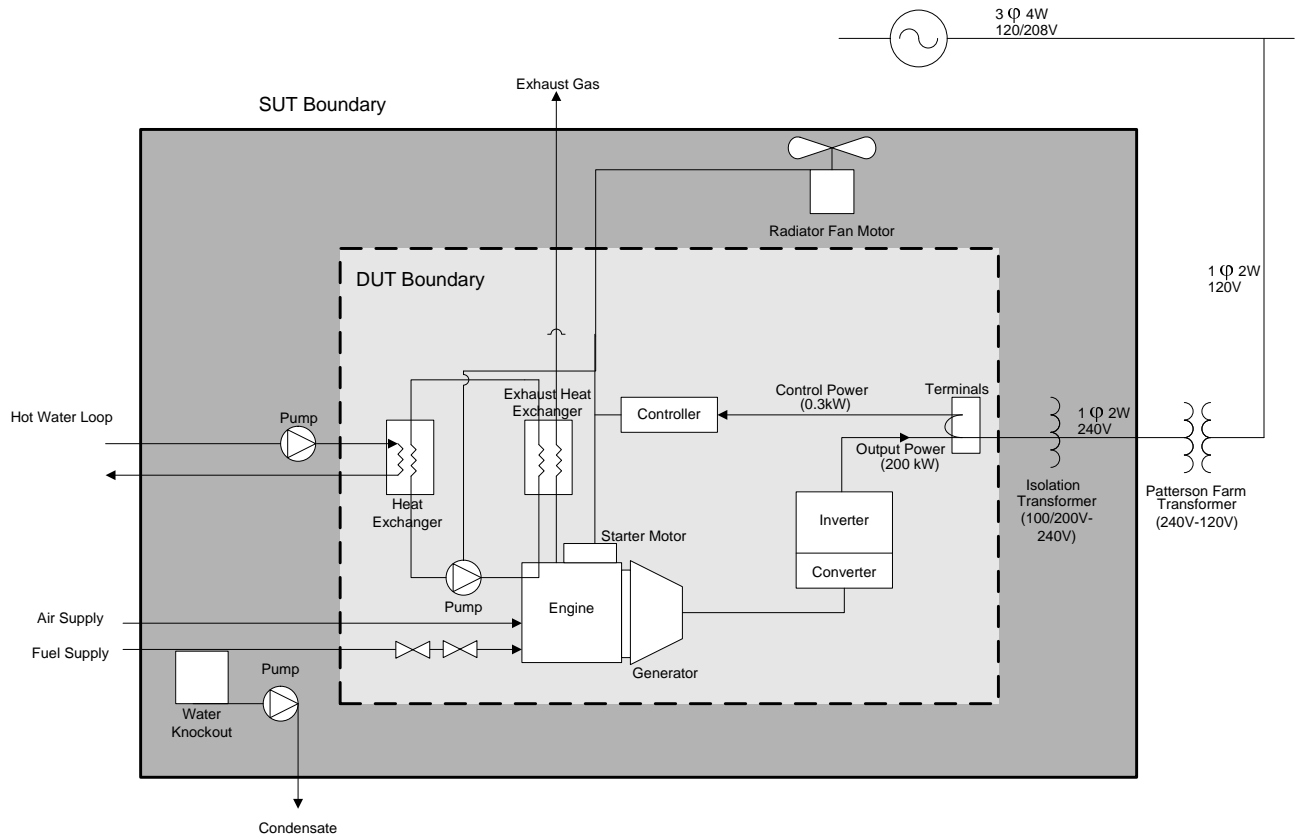

Figure 2-1. The Patterson Farm DG/CHP System Boundary Diagram

2.2 VERIFICATION PARAMETERS

The defined SUT will be tested to determine performance for the following verification parameters:

- Electrical Performance
- Electrical Efficiency
- CHP Thermal Performance
- Emissions Performance
- NO_x and CO₂ Emission Offsets

The test sequences and durations will follow the guidelines specified in GVP §1.3. There will be three separate one-hour test runs conducted at each of the specified operating points. Permissible measurement variability criteria for IC engines presented in GVP §2.2.1 will apply to this testing. In addition to these verification parameters, this verification will also include estimation of NO_x and greenhouse gas (CO₂) emissions reductions realized through use of the digester and cogeneration system at this test location. The approach and methodology for these estimations are provided in §2.2.4 and Appendix A of this test plan.

The following sections identify the sections of the protocol that are applicable to the verification parameters for this test, identify site specific instrumentation for each (Table 2-1), and specify any exceptions or deviations.

2.2.1 Electrical Performance (GVP §2.0)

Determination of electrical performance will be conducted following §2.0 and Appendix D1.0 of the GVP. The following parameters will be measured:

- Real power, kW
- Apparent power, kVA
- Reactive power, kVAR
- Power factor, %
- Voltage total harmonic distortion, %
- Current total harmonic distortion, %
- Frequency, Hz
- Voltage, V
- Current, A

The verification parameters will be measured with a digital power meter manufactured by Power Measurements Ltd. (Model 7500 or 7600 ION). The meter scans all power parameters once per second and computes and records one-minute averages. Test personnel will install the power meter on the cogeneration unit. The meter will operate continuously, unattended, and will not require further adjustments after installation. The rated accuracy of the power meter is ± 0.1 percent, and the rated accuracy of the current transformers (CTs) needed to employ the meter at this site is ± 0.5 percent. Overall power measurement error is then ± 0.5 percent.

2.2.2 Electrical Efficiency (GVP §3.0)

Determination of electrical efficiency will be conducted following §3.0 and Appendix D2.0 of the GVP. The following parameters will be measured:

- Real power production, kW
- External parasitic load power consumption, kW
- Ambient temperature, °F
- Ambient barometric pressure, psia
- Fuel LHV, Btu/scf
- Fuel consumption, scfh

Real power production and external parasitic load consumption will be measured by the Power Measurements Ltd. Digital power meter, as described in §2.2.1 above. Ambient temperature will be recorded on the datalogger from a single Class A 4-wire RTD. The specified accuracy of the RTD will be ± 0.6 °F. Ambient barometric pressure will be measured by a Setra Model 280E ambient pressure sensor with a full scale (FS) of 0 – 25 psia and an accuracy of $\pm 1\%$ FS.

Gas flow will be measured by a Model 5M175 Series B3 Roots Meter manufactured by Dresser Measurement with a specified accuracy of $\pm 1\%$. Gas temperature will be measured by a Class A 4-wire platinum resistance temperature detector (RTD). The specified accuracy of the RTD is ± 0.6 °F. Gas pressure will be measured by an Omega Model PX205 Pressure Transducer. The specified accuracy of

the pressure transducer is $\pm 0.25\%$ of reading over a range of 0 – 30 psia. At least three gas samples will be collected in 500 ml stainless steel canisters and shipped to subcontractor Empact Analytical of Brighton, Colorado for LHV analysis according to ASTM Method 1945. The QA Manager will confirm that the subcontractor satisfies the required QA elements of the method.

The external parasitic loads introduced by the heat transfer circulation pump, the gas filtration system, and the radiator fan motor will be verified using a Fluke Model 336 clamp on power meter. The meter has rated accuracies of 2 percent of reading for current and 1% of reading for voltage.

2.2.3 CHP Thermal Performance (GVP §4.0)

Determination of CHP thermal performance will be conducted following §4.0 and Appendix D3.0 of the GVP. The following parameters will be quantified:

- Thermal performance in heating service, Btu/h
- Thermal efficiency in heating service, %
- Actual SUT efficiency in heating service as the sum of electrical and thermal efficiencies, %

To quantify these parameters, heat recovery rate from the DUT will be measured on the heat transfer loop and defined as the heat delivered to the facility. This verification does not include quantification of the heat recovered by the heat transfer fluid to hot water heat exchanger. This verification will employ a Sparling Economag Model FM618 Electromagnetic Flowmeter with a nominal linear range of 0 to 40 gpm. Accuracy of this meter is $\pm 1.0\%$ of reading. Class A 4-wire platinum resistance temperature detectors (RTDs) will be used to determine the transfer fluid supply and return temperatures. The specified accuracy of the RTDs is $\pm 0.6\text{ }^\circ\text{F}$. Pretest calibrations will document the RTD performance. Following Section 4.2 of the GVP, CHP performance determinations also require heat transfer fluid density (ρ) and specific heat (c_p). These values may be obtained from standard tables for water.

2.2.4 Emissions Performance (GVP §5.0)

Determination of emissions performance will be conducted following §5.0 and Appendix D4.0 of the GVP. Consistent with all of the DG/CHP verifications conducted for NYSERDA, this verification will include only emissions of NO_x , CO, CO_2 , and THC. Emissions testing will be performed by GHG Center Personnel using a portable emissions monitoring system (PEMS). The PEMS is an Horiba OBS-2200 system, which is essentially a miniaturized laboratory analyzer bench which has been optimized for portable use. The instrument meets or exceeds Title 40 CFR 1065 requirements for in-use field testing of engine emissions.

This PEMS is suitable for testing a wide variety of stationary sources as well as the mobile sources for which it is intended. Accuracy for all analytes is better than $\pm 2.5\%$ full scale (FS), while linearity is better than $\pm 1.0\%$ FS. Exhaust gas concentrations must be integrated with exhaust gas flow rates to yield mass emission rates or brake-specific emissions. EPA Method 2 will be used to determine exhaust gas volumetric flow rates.

Response times for all OBS-2200 analyzers are approximately 2 seconds alone and 5 seconds with the heated umbilical in the sample line. Test personnel establish exact analyzer response times prior to testing. Software algorithms then align analyzer data outputs with other sensor signals, such as exhaust gas flow and engine control module data. Resolution depends on the analyzer range setting, but is between 4 and 5 significant digits.

The OBS-2200 measures CO and CO₂ with non-dispersive infra-red (NDIR) detectors. The OBS-2200 does not require a separate moisture removal system for the CO and CO₂ NDIR detectors. The NO_x analyzer section consists of a chemiluminescence detector with a NO₂/NO converter. This is the kind of system specified in Title 40 CFR 60, Appendix A, Method 7E, "Determination of Nitrogen Oxides Emissions from Stationary Sources", which is a reference method for NO_x.

The OBS-2200 measures THC with a FID. This method corresponds to the system specified in Title 40 CFR 60 Appendix A, Method 25, "Determination of Total Gaseous Non-methane Organic Emissions as Carbon", which is a reference method for THC.

The PEMS sample pump conveys all samples through a heated umbilical directly to heated analyzer sections which eliminates the need to remove moisture and eliminates possible moisture scavenging.

Proposed calibration ranges for the gas analyzers are listed in Table 2-1. Results for each pollutant will be reported in units of ppm, ppm corrected to 15% O₂, lb/h, and lb/kWh.

2.2.5 Field Test Procedures and Site Specific Instrumentation

Field test procedures will follow the guidelines and procedures detailed in the following sections of the GVP:

- Electrical performance - §7.1
- Electrical efficiency - §7.2
- CHP thermal performance - §7.3
- Emissions performance - §7.4

Load tests will be conducted as three one-hour test replicates at cogeneration power commands of approximately 200, 150, and 100 kW. In addition to the controlled tests, system performance will be monitored continuously for a period of approximately one month while the unit operates under normal farm operations. Continuous measurements will be recorded during the entire period including:

- Power output,
- Power quality parameters,
- Fuel consumption (gas flow, pressure, and temperature),
- Heat recovery rate (transfer fluid flow, supply temperature, and return temperature),
- Heat transfer fluid circulation pump power consumption, and
- Ambient conditions (temperature and pressure).

Using these data, the GHG Center can evaluate DG/CHP system performance and usage rates for Patterson Farms under typical facility operations.

Site specific measurement instrumentation is summarized in Table 2-1. The location of the instrumentation relative to the SUT is illustrated in Figures 2-2 and 2-3. All measurement instrumentation meets the GVP specifications.

Table 2-1. Site Specific Instrumentation for Patterson Farms DG/CHP System Verification

Verification Parameter	Supporting Measurement	Expected Range of Measurement	Instrument	Instrument Range	Instrument Accuracy
Electrical Performance	Real power	0.0 – 200 kW	Power Measurements Ltd. ION power meter (Model 7600 or 7500)	0 – 260 kW	± 0.1% of reading
	Power factor	90 – 100 %		0 – 100 %	± 0.5% of reading
	Voltage THD	0 – 100 %		0 – 100 %	± 1% FS
	Current THD	0 – 100 %		0 – 100 %	± 1% FS
	Frequency	58 – 62 Hz		57 – 63 Hz	± 0.01% of reading
	Voltage	240 V		0 – 600 V	± 0.11% of reading
	Current	300 - 600 A		0 – 400 A	± 0.11% of reading
	Ambient temperature	20 – 40 °F	Omega Class A 4-wire RTD	0 – 250 °F	± 0.6 °F
	Barometric pressure	14.5 – 15.0 psia	Setra Model 280E	0 – 25 psia	± 0.1% FS
	Parasitic loads	1000 W	Fluke Model 336 portable power meter	0 – 260 kW	± 2% of reading
Electrical Efficiency	Gas flow	2400 - 4800 cfh	Model 5M175 Roots Meter	0 – 5000 cfh	± 1% of reading
	Gas pressure	5 – 20 in. w.c.	Omega PX205 Pressure Transducer	0-30 psia	± 0.25% of reading
	Gas temperature	50 – 90 °F	Omega Class A 4-wire RTD	0 – 250 °F	± 0.6 °F
CHP Thermal Performance	Heat tranfer loop flow	10 – 20 gpm	Sparling Economag Model FM618	0 – 40 gpm	± 1.0% of reading
	Heat tranfer supply temp.	180 – 200 °F	Omega Class A 4-wire RTD	0 – 250 °F	± 0.6 °F
	Heat tranfer return temp.	170 – 190 °F	Omega Class A 4-wire RTD	0 – 250 °F	± 0.6 °F
Emissions Performance	NO _x concentration	100 – 300 ppmv	Chemiluminescence	0 – 1000 ppmv	± 2% FS
	CO concentration	100 – 300 ppmv	(NDIR)-gas filter correlation	0 – 1000 ppmv	± 2% FS
	CO ₂ concentration	5 – 10 %	NDIR	0 – 20 %	± 2% FS
	O ₂ concentration	8 – 15 %	Electrochemical cell	0 – 25 %	± 2% FS
	THC concentration	100 – 300 ppmv	Flame ionization detector (FID)	0 – 1000 ppmv	± 2% FS

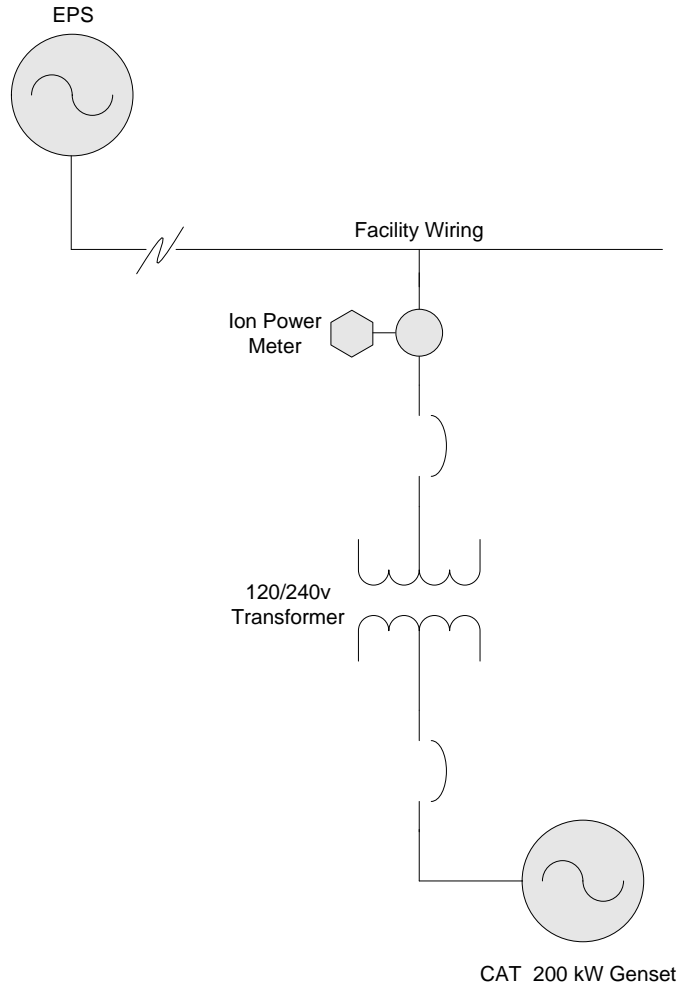

Figure 2-2. Position of Test Instrumentation for SUT Electrical System

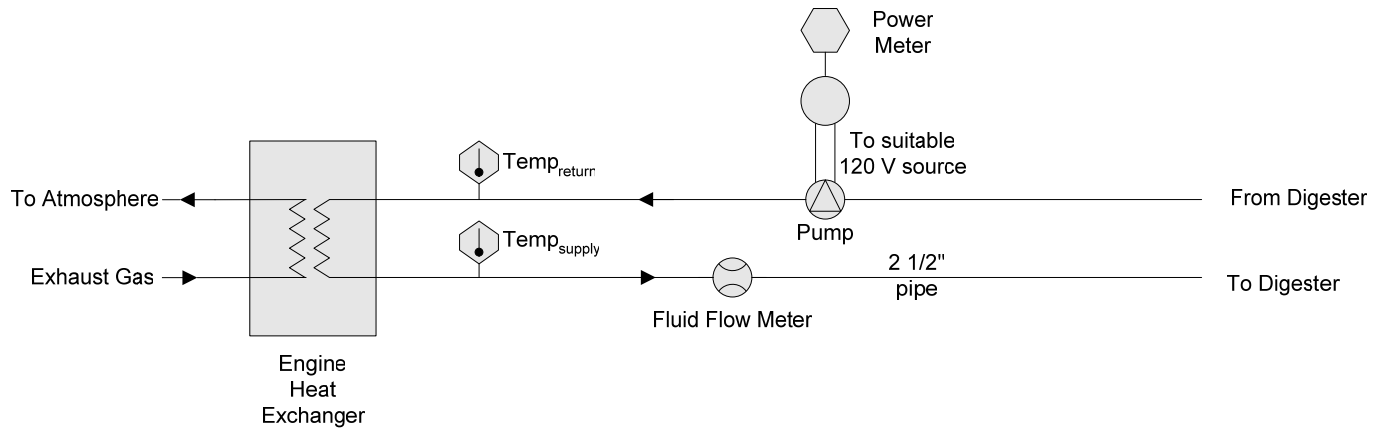

Figure 2-3. Location of Test Instrumentation for SUT Thermal System

2.2.6 Estimated NO_x and CO₂ Emission Offsets

This verification parameter is not included in the GVP, so the approach and procedures to be used in this verification are described here. Use of the DG/CHP cogeneration system at this facility will change the NO_x and CO₂ emission rates associated with the operation of the Patterson Farms facility. Annual emission offsets for these pollutants will be estimated and reported by subtracting emissions of the on-site CHP unit from emissions associated with baseline electrical power generation technology. Appendix A provides the procedure for estimating emission reductions resulting from electrical generation. The procedure correlates the estimated annual electricity savings in MWh with New York and nationwide electric power system emission rates in lb/MWh. For this verification, analysts will assume that the Patterson Farms DG/CHP system generates power at a rate similar to that recorded during the 1 week verification monitoring period throughout the entire year.

Since the heat recovered is currently only used to warm the digester, there is no real baseline emissions offset associated with heat production. Should the capacity to warm the milking parlor with CHP recovered heat be added at a later date, then additional emissions offset are likely at this site due to the reduction of utility provided energy in the parlor. Emission reductions associated with use of farm waste as fuel will not be conducted, as this process requires baseline GHG emission assessments of standard waste management practices. Due to the significant resources required to do this, this analysis is beyond the scope of this project, and therefore this verification includes emission reductions from electricity generation only.

3.0 DATA QUALITY OBJECTIVES

Under the ETV program, the GHG Center specifies data quality objectives (DQOs) for each verification parameter before testing commences as a statement of data quality. The DQOs for this verification were developed based on past DG/CHP verifications conducted by the GHG Center, input from EPA’s ETV QA reviewers, and input from both the GHG Centers’ executive stakeholders groups and industry advisory committees. As such, test results meeting the DQOs will provide an acceptable level of data quality for technology users and decision makers. The DQOs for electrical and CHP performances are quantitative, as determined using a series of measurement quality objectives (MQOs) for each of the measurements that contribute to the parameter determination:

<u>Verification Parameter</u>	<u>DQO (relative uncertainty)</u>
Electrical Performance	±2.0 %
Electrical Efficiency	±3.0 %
CHP Thermal Efficiency	±3.5 %

Each test measurement that contributes to the determination of a verification parameter has stated MQOs, which, if met, ensure achievement of that parameter’s DQO. This verification is based on the GVP which contains MQOs including instrument calibrations, QA/QC specifications, and QC checks for each measurement used to support the verification parameters being evaluated. Details regarding the measurement MQOs are provided in the following sections of the GVP:

- § 7.1 Electrical Performance Data Validation
- § 7.2 Electrical Efficiency Data Validation
- § 7.3 CHP Performance Data Validation

The DQO for emissions is qualitative in that the verification will produce emission rate data that satisfies the QC requirements contained in the EPA Reference Methods specified for each pollutant. The verification report will provide sufficient documentation of the QA/QC checks to evaluate whether the qualitative DQO was met. Details regarding the measurement MQOs for emissions are provided in the following section of the GVP:

- § 7.4 Emissions Data Validation

Completeness goals for this verification is to obtain valid data for 90 percent of the test periods (controlled test period and extended monitoring).

4.0 DATA ACQUISITION, VALIDATION, AND REPORTING

4.1 DATA ACQUISITION AND DOCUMENTATION

Test personnel will acquire the following electronic data and generate the following documentation during the verification:

Electronic Data

Electronic data will be monitored for the following measurements:

- power output and power quality parameters
- fuel flow, pressure, and temperature
- transfer fluid flow, supply temperature, and return temperature
- ambient temperature and barometric pressure

The ION power meter will poll their sensors once per second. They will then calculate and record one-minute averages throughout all tests. The field team leader will download the one-minute data directly to a laptop computer during the short-term tests. GHG Center personnel will download the data by telephone during the long term monitoring period.

An Agilent / HP Model 34970A datalogger will record all of the temperature, pressure, and flow meter data once every 5 seconds. The field team leader will download the data directly during short-term tests while GHG Center will download the data by telephone during the long term monitoring period. Analysts will use Excel spreadsheet routines to calculate one-minute averages from the 5-second snapshots.

The electronically-recorded one-minute averages (except for the manually-logged water system pressure data) will be the source data for all calculated results.

Documentation

Printed or written documentation will be recorded on the log forms provided in Appendix B of the GVP and will include:

- Daily test log, including water system pressure data, starting and ending times for test runs, notes, etc.
- GVP Appendix A forms which show the results of QA / QC checks
- Copies of calibrations and manufacturers' certificates

The GHG Center will archive all electronic data, paper files, analyses, and reports at their Research Triangle Park, NC office in accordance with their quality management plan.

4.1.1 Corrective Action and Assessment Reports

A corrective action will occur if audits or QA / QC checks produce unsatisfactory results or upon major deviations from this TQAP. Immediate corrective action will enable quick response to improper procedures, malfunctioning equipment, or suspicious data. The corrective action process involves the field team leader, project manager, and QA Manager. The GHG Center QMP requires that test personnel submit a written corrective action request to document each corrective action.

The field team leader will most frequently identify the need for corrective actions. In such cases, he or she will immediately notify the project manager. The field team leader, project manager, QA Manager and other project personnel, will collaborate to take and document the appropriate actions.

Note that the project manager is responsible for project activities. He is authorized to halt work upon determining that a serious problem exists. The field team leader is responsible for implementing corrective actions identified by the project manager and is authorized to implement any procedures to prevent a problem's recurrence.

4.2 DATA REVIEW, VALIDATION, AND VERIFICATION

The project manager will initiate the data review, validation, and analysis process. At this stage, analysts will classify all collected data as valid, suspect, or invalid. The GHG Center will employ the QA/QC criteria specified in Section 3.0 and the associated tables. Source materials for data classification include factory and on-site calibrations, maximum calibration and other errors, subcontractor deliverables, etc.

In general, valid data results from measurements which:

- meet the specified QA/QC checks, including subcontractor requirements,
- were collected when an instrument was verified as being properly calibrated, and
- are consistent with reasonable expectations (e.g., manufacturers' specifications, professional judgment).

The report will incorporate all valid data. Analysts may or may not consider suspect data, or it may receive special treatment as will be specifically indicated. If the DQO cannot be met, the project manager will decide to continue the test, collect additional data, or terminate the test and report the data obtained.

Data review and validation will primarily occur at the following stages:

- on site -- by the field team leader,
- upon receiving subcontractor deliverables,
- before writing the draft report -- by the project manager, and
- during draft report QA review and audits -- by the GHG Center QA Manager.

The field team leader's primary on-site functions will be to install and operate the test equipment. He will review, verify, and validate certain data (QA / QC check results, etc.) during testing. The log forms in Appendix B of the GVP provide the detailed information he will gather.

The QA Manager will use this TQAP and documented test methods as references with which to review and validate the data and the draft report. He will review and audit the data in accordance with the GHG Center's quality management plan. For example, the QA Manager will randomly select raw data, including data generated and submitted by subcontractors, and independently calculate the verification parameters. The comparison of these calculations with the results presented in the draft report will yield an assessment of the GHG Center's QA/QC procedures.

4.3 INSPECTION/ACCEPTANCE OF SUPPLIES, CONSUMABLES, AND SERVICES

The procurement of purchased items and services that directly affect the quality of environmental programs defined by this TQAP will be planned and controlled to ensure that the quality of the items and

services is known, documented, and meets the technical requirements and acceptance criteria herein. For this verification, this includes services provided by Empact Analytical for fuel analyses and O'Brien & Gere, Inc. for emissions testing services.

Procurement documents shall contain information clearly describing the item or service needed and the associated technical and quality requirements. The procurement documents will specify the quality system elements of the GVP for which the supplier is responsible and how the supplier's conformity to the customer's requirements will be verified.

Procurement documents shall be reviewed for accuracy and completeness by the project manager and QA manager as noted in Sections 1.4 and 4.2. Changes to procurement documents will receive the same level of review and approval as the original documents. Appropriate measures will be established to ensure that the procured items and services satisfy all stated requirements and specifications.

4.4 DATA QUALITY OBJECTIVES RECONCILIATION

A fundamental component of all verifications is the reconciliation of the collected data with its DQO. In this case, the DQO assessment consists of evaluation of whether the stated methods were followed, MQOs achieved, and overall accuracy is as specified in the GVP. The field team leader and project manager will initially review the collected data to ensure that they are valid and are consistent with expectations. They will assess the data's accuracy and completeness as they relate to the stated QA / QC goals. If this review of the test data show that QA / QC goals were not met, then immediate corrective action may be feasible, and will be considered by the project manager. DQOs will be reconciled after completion of corrective actions. As part of the internal audit of data quality, the GHG Center QA Manager will include an assessment of DQO attainment.

4.5 ASSESSMENTS AND RESPONSE ACTIONS

The field team leader, project manager, QA Manager, GHG Center Director, and technical peer-reviewers will assess the project and the data's quality as the test campaign proceeds. The project manager and QA Manager will independently oversee the project and assess its quality through project reviews, inspections if needed, and an audit of data quality.

4.5.1 Project Reviews

The project manager will be responsible for conducting the first complete project review and assessment. Although all project personnel are involved with ongoing data review, the project manager must ensure that project activities meet measurement and DQO requirements. The project manager is also responsible for maintaining document versions, managing the review process, and ensuring that updated versions are provided to reviewers and tracked.

The GHG Center Director will perform the second project review. The director is responsible for ensuring that the project's activities adhere to the ETV program requirements and stakeholder expectations. The GHG Center Director will also ensure that the field team leader has the equipment, personnel, and resources to complete the project and to deliver data of known and defensible quality.

The QA Manager will perform the third review. He is responsible for ensuring that the project's management systems function as required by the quality management plan. The QA Manager is the GHG Center's final reviewer, and he is responsible for ensuring the achievement of all QA requirements.

ECOTS and NYSERDA personnel will then review the report. ECOTS will also have the opportunity to insert supplemental unverified information or comments into a dedicated report section.

The GHG Center will submit the draft report to EPA QA personnel, and the project manager will address their comments as needed. Following this review, the report will undergo EPA management reviews, including the GHG Center Director, EPA ORD Laboratory Director, and EPA Technical Editor.

4.5.2 Test/QA Plan Implementation Assessment

The GHG Center has previously conducted numerous internal technical systems audits (TSAs) of the methods and procedures proposed for this verification and will therefore not repeat a TSA for this test. However, the GHG Center QA Manager or designee will conduct a readiness review and observe and document a pre-test assessment and bench test of the measurements system including the following systems:

- flow meters, transmitter, and datalogger
- temperature and pressure sensors and datalogger
- power consumption meters

During the assessment, the QA Manager will verify that the equipment, procedures, and calibrations are as specified in this TQAP. Should the QA Manager note any deficiencies in the implementation of the TQAP, corrective actions will be immediately implemented by the project manager. The QA Manager will document this assessment in a separate report to the GHG Center Director.

EPA QA management is planning to conduct an external TSA on this verification which will include on-site assessment of the equipment, procedures, and calibrations.

4.5.3 Audit of Data Quality

The audit of data quality is an evaluation of the measurement, processing, and data analysis steps to determine if systematic errors are present. The QA Manager, or designee, will randomly select approximately 10 percent of the data. He will follow the selected data through analysis and data processing. This audit is intended to verify that the data-handling system functions correctly and to assess analysis quality. The QA Manager will also include an assessment of DQO attainment.

The QA Manager will route audit results to the project manager for review, comments, and possible corrective actions. The ADQ will result in a memorandum summarizing the results of custody tracing, a study of data transfer and intermediate calculations, and review of the QA/QC data. The ADQ report will include conclusions about the quality of the data from the project and their fitness for the intended use. The project manager will take any necessary corrective action needed and will respond by addressing the QA Manager's comments in the verification report.

4.6 VERIFICATION REPORT AND STATEMENT

The project manager will coordinate report preparation. The report will summarize each verification parameter's results as discussed in Section 2.0 but will not include the raw data or QA/QC checks that support the findings. All raw and processed measurements data as well as calibration data and QA/QC checks will be made available to EPA as a separate CD, and can be provided to other parties interested in assessing data trends, completeness, and quality by request. The report will clearly characterize the

verification parameters, their results, and supporting measurements as determined during the test campaign. The report will also contain a Verification Statement, which is a 3 to 5 page document summarizing the technology, the test strategy used, and the verification results obtained.

The project manager will submit the draft report and Verification Statement to the QA Manager and GHG Center Director for review. A preliminary outline of the report is as follows:

***Preliminary Outline
Patterson Farms DG/CHP Verification Report***

Verification Statement

*Section 1.0: Verification Test Design and Description
Description of the ETV program
Patterson Farms DG/CHP System Description
Overview of the Verification Parameters and Evaluation Strategies*

*Section 2.0: Results
Electrical performance
Electrical efficiency
CHP performance
Atmospheric emissions
NO_x and CO₂ emission offsets*

Section 3.0: Data Quality

Section 4.0: Additional Technical and Performance Data Supplied by Patterson Farms (optional)

Section 5.0: References

Appendices: Raw Verification or Other Data

4.7 TRAINING AND QUALIFICATIONS

This test does not require specific training or certification beyond that required internally by the test participants for their own activities. The GHG Center's project manager has approximately 20 years experience in field testing of air emissions from many types of sources and will directly oversee field activities. He is familiar with the test methods and standard requirements that will be used in the verification test.

The field team leader has performed numerous field verifications under the ETV program, and is familiar with EPA and GHG Center quality management plan requirements. The QA Manager is an independently appointed individual whose responsibility is to ensure the GHG Center's conformance with the EPA approved QMP.

4.8 HEALTH AND SAFETY REQUIREMENTS

This section applies to GHG Center personnel only. Other organizations involved in the project have their own health and safety plans which are specific to their roles in the project.

GHG Center staff will comply with all known host, state/local and Federal regulations relating to safety at the test facility. This includes use of personal protective gear (such as safety glasses, hard hats, hearing protection, safety toe shoes) as required by the host and completion of site safety orientation.

5.0 REFERENCES

- [1] *Distributed Generation and Combined Heat and Power Field Testing Protocol, DG/CHP Version*, Association of State Energy Research and Technology Transfer Institutions, Madison, WI, October 2004.
- [2] *Inventory of U.S. Greenhouse Gas Emissions and Sinks: 1990 – 1999, Annex A: Methodology for Estimating Emissions of CO₂ from Fossil Fuel Combustion*, U.S. Environmental Protection Agency, EPA 236-R-01-001, Washington, DC, 2001.
- [3] *DAP-42, Compilation of Air Pollutant Emission Factors – Volume 1, Stationary Point and Area Sources, Fifth Edition*, U.S. Environmental Protection Agency, Office of Transportation and Air Quality, Washington, DC, 1995.

Appendix A Electric Power System Emissions Reduction Estimates

The verification report will provide estimated emissions reductions (or increases) as compared to aggregated electric power system (EPS) emission rates for the state in which the apparatus is located (New York for this verification). The report will also include estimated reductions based on aggregated nationwide emission rates. Analysts will employ the methods described in this Appendix.

A DG asset or power-saving device, when connected to the EPS, will change the overall EPS emissions signature. As an example, a zero-emission generator, such as a hydroelectric power plant, will decrease EPS CO₂ emissions on a lb/MWh basis. The potential emissions reduction (or increase) for DG is the difference between the EPS and DG emission rates, multiplied by the expected power generation or savings rate:

$$Reduction_i = (ER_{EPS,i} - ER_{DG,i}) * MWh_{DG,Ann} \quad \text{Eqn. A1}$$

Where:

- Reduction_i = annual reduction for pollutant i, pounds per year (lb/y)
- ER_{EPS,i} = EPS emission rate for pollutant i (see below), pounds per megawatt-hour (lb/MWh)
- ER_{DG,i} = DG emissions rate for pollutant i, lb/MWh
- MWh_{DG,Ann} = annual estimated DG power production or device-based power savings, megawatt-hours per year (MWh/y)

The potential emissions reduction for a power savings device is simply:

$$Reduction_i = ER_{EPS,i} * MWh_{Device,Ann} \quad \text{Eqn. A2}$$

Values for ER_{DG,i} are available from the performance verification results. Estimated MWh_{DG,Ann} or MWh_{Device,Ann} should also be available from the verification results. This estimate depends on the specific verification strategy and its derivation should be clearly described in the TQAP and verification results. A simple example is the power production or power savings multiplied by the annual availability or capacity factor. For example, a 200 kW fuel cell which operates at full capacity 75 percent of the time can be expected to generate 1314 MWh annually.

ER_{EPS,i} for specific pollutants can vary widely because the EPS may obtain its power from many different generators. The generation mix can change dramatically from hour to hour, depending on market forces, system operations, wheeling practices, emergencies, maintenance, and other factors. Many different approaches have been suggested for estimating ER_{EPS,i}, but no consensus has been achieved.

The following estimation methodology is simple, it uses peer-reviewed carbon dioxide (CO₂), nitrogen oxide (NO_x), mercury (Hg), and sulfur dioxide (SO₂) data available from the US Environmental Protection Agency's "EGRID" database, and it provides some analysis flexibility.

EGRID is available from www.epa.gov/cleanenergy/egrid/download.htm. At this writing, data is available through 2000. The example presented here is for a generator located in Florida, but this procedure can be used for any state. Data through 2003 will likely be available in late 2005. Figure A-1 shows the introductory screen prompts which provide year 2000 emission rates for Florida.

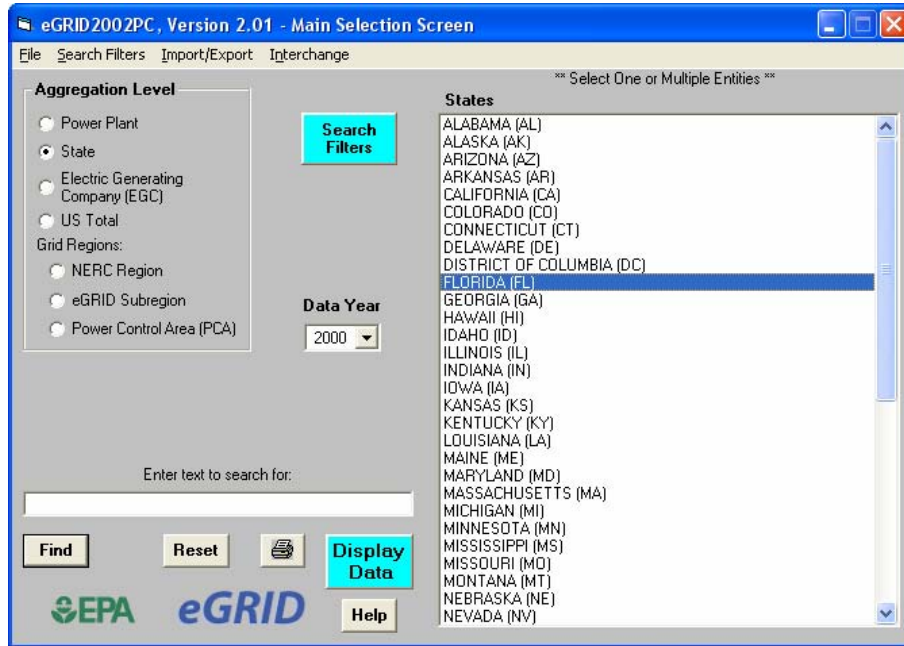

Figure A-1. Example Aggregated Emissions Introductory Screen

Double-clicking the state of interest brings up the emissions data, as shown in Figure A-2.

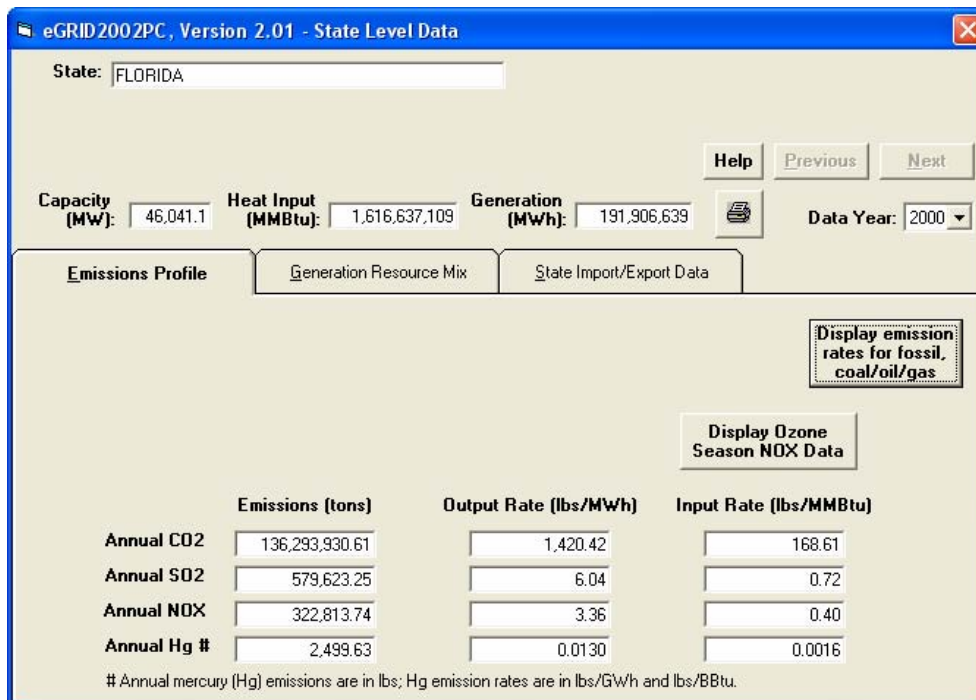

Figure A-2. Example EPS Emission Rates for 2000

Figure A-3 provides the nationwide emission rates for 2000.

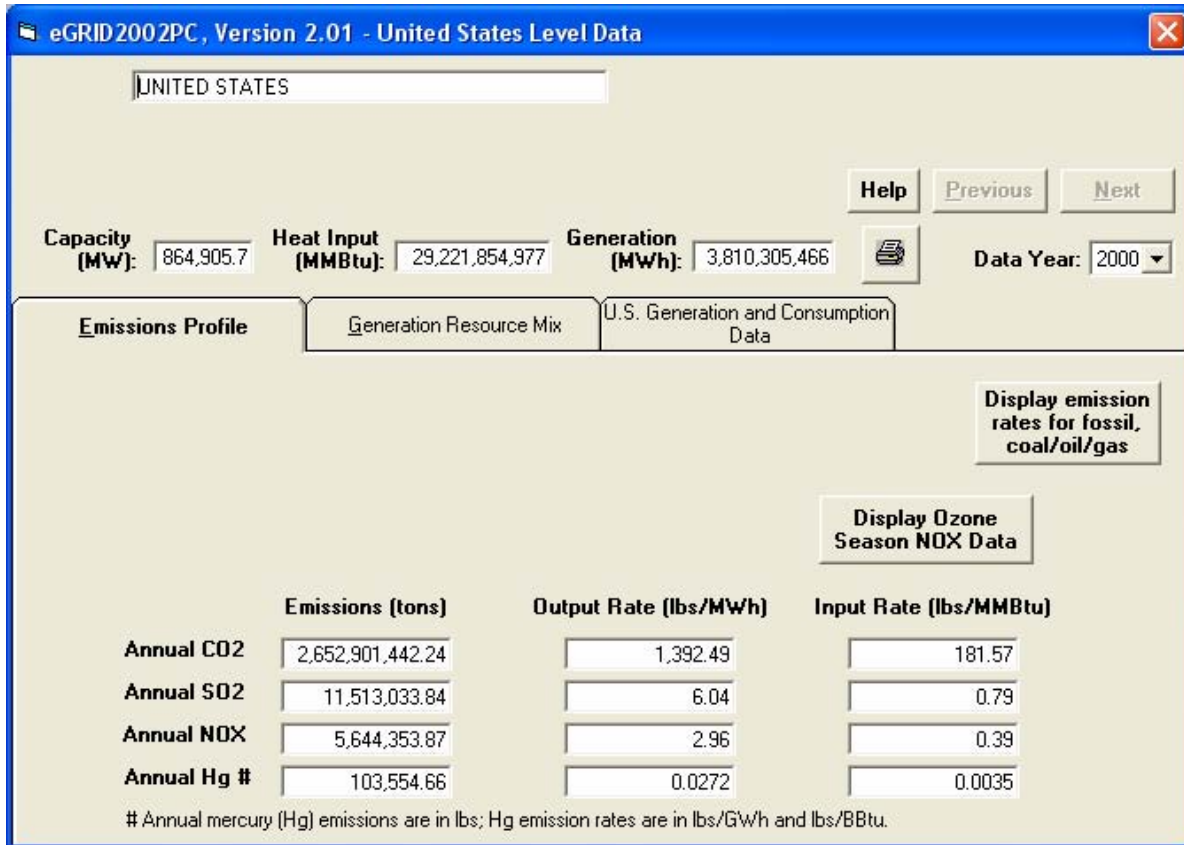

Figure A-3. Nationwide Emission Rates

These results form the basis for comparison. Table A-1 provides emissions offsets estimates for a hypothetical 200 kW fuel cell located in Florida.

Pollutant	Florida		Nationwide	
	CO ₂	NO _x	CO ₂	NO _x
ER _{EPS} (from EGRID), lb/MWh	1420	3.36	1392	2.96
ER _{DG} (from verification tests), lb/MWh	1437	0.13	1437	0.13
ER _{EPS} - ER _{DG} , lb/MWh	-17 ^a	3.23	-45 ^a	2.83
DG capacity, kW	200		200	
Estimated availability or capacity factor	75 %		75 %	
MWh _{DG, Ann}	1314		1314	
Emission offset, lb/y	-22400	4250	-59130	3720

^aNegative numbers represent an increase over the EPS emission rate

Note that this fuel cell increases the overall EPS CO₂ emission rate if electricity generation alone is considered. The increased CO₂ emissions in this example would be balanced by the fuel cell's heat or chilling power production if it is in combined chilling / heat and power (CHP) service. Each verification TQAP must provide a specific accounting methodology for electricity production and CHP utilization because it is impossible to consider all the permutations here. The simplest case, that the unit really

operates at a constant power output, predictable availability (or capacity factor), and that all the heat produced is actually used, is not necessarily true for every installation. Also, the CHP application may displace units fired by various fuels (electricity, heating oil, natural gas, etc.) with their own efficiencies and emission factors. Each verification strategy should explicitly discuss these considerations as part of the specific emissions offset calculation.

It is useful, however, to continue this example. Assume that the fuel cell provides a constant 800,000 British thermal units per hour (Btu/h) to a domestic hot water system, thus displacing an electric-powered boiler. This heat production is equivalent to 234 kW, which would require approximately 239 kW of electricity from the EPS at 0.98 water heating efficiency (source: ASHRAE Standard 118.1-2003, § 9.1). The fuel cell would therefore save approximately 15700 MWh annually at 75 percent capacity factor. Table A-2 shows the resulting emissions offsets estimates.

Table A-2. Example CHP Emissions Offsets Estimates				
	Florida		Nationwide	
Pollutant	CO ₂	NO _x	CO ₂	NO _x
ER _{EPS} (from EGRID), lb/MWh	1420	3.36	1392	2.96
ER _{DG} (from verification tests), lb/MWh	0 ^a	0 ^a	0 ^a	0 ^a
ER _{EPS} - ER _{DG} , lb/MWh	1420	3.36	1392	2.96
DG capacity, kW	239 ^b		239 ^b	
Estimated availability or capacity factor	75 %		75 %	
MWh _{DG, Ann}	15700		15700	
Emission offset, lb/y	2.23 x 10 ⁷ (11100 tons)	52800 (26.4 tons)	2.19 x 10 ⁷ (10900 tons)	46500 (23.2 tons)
^a Emissions are zero here because the electricity production offset estimate included them.				
^b Based on the power required to run an electric-fired boiler at 98 % water heating efficiency.				

In this CHP application, the fuel cell represents a considerable net annual CO₂ emissions reduction for New York of 2.23 x 10⁷ lb/y.

This approach is generally conservative because it does not include transmission and distribution (T&D) losses. T&D losses vary between approximately 3 to 8 percent depending on dispatch practices, the unit's location with respect to the EPS generator actually being displaced, and other factors. This means that 100 kW of energy at the DG unit's terminals will actually displace between 103 and 109 kW (and the associated emissions) at the EPS generator.

EGRID provides numerous other aggregation options, and the reader may wish to conduct other comparisons, such as for a particular utility, North American Electric Reliability Council (NERC) region, or control area.