

US EPA ARCHIVE DOCUMENT

September 2003

Environmental Technology Verification Protocol

BIOREACTION SYSTEM CONTROL TECHNOLOGIES FOR VOLATILE ORGANIC COMPOUND EMISSIONS

Prepared by:



Under a Cooperative Agreement with

U. S. Environmental Protection Agency

ET ✓ ET ✓ ET ✓

US EPA ARCHIVE DOCUMENT

**GENERIC VERIFICATION PROTOCOL FOR
BIOREACTION SYSTEM CONTROL TECHNOLOGIES
FOR VOLATILE ORGANIC COMPOUND EMISSIONS**

EPA Cooperative Agreement No. CR826152-01-3
RTI Project No. 08281.001.006

Prepared by:



Approved by:

| | | | |
|------------------------|----------------|---|---------------------|
| APCTV Program Manager: | J. R. Farmer | <u>Original signed by J.R. Farmer</u> | Date <u>10/7/03</u> |
| APCTV Task Leader: | A. R. Trenholm | <u>Original signed by A.R. Trenholm</u> | Date <u>10/7/03</u> |
| APCTV Quality Manager: | C. E. Tatsch | <u>Original signed by C.E. Tatsch</u> | Date <u>10/8/03</u> |
| EPA Project Manager: | T. G. Brna | <u>Original signed by T.G. Brna</u> | Date <u>9/30/03</u> |
| EPA Quality Manager: | P. W. Groff | <u>Original signed by P.W. Groff</u> | Date <u>9/30/03</u> |

This page intentionally left blank

TABLE OF CONTENTS

ACRONYMS AND ABBREVIATIONS 5

1.0 INTRODUCTION 7

 1.1 Environmental Technology Verification 7

 1.2 Air Pollution Control Technology Verification Center 7

 1.3 Bioreaction Air Pollution Control Technology 8

 1.4 The APCTVC Bioreaction System Control Technology Verification 9

 1.5 Quality Management Documents 9

2.0 OBJECTIVE, SCOPE, AND VERIFICATION FACTORS 10

 2.1 Objective 10

 2.2 Scope 10

 2.3 Products to be Tested 11

 2.4 Verification Parameters 11

 2.5 Data Quality Objectives (DQOs) 14

3.0 TEST PROGRAM 16

 3.1 Verification Testing Responsibilities 16

 3.2 Test Design 17

 3.2.1 Technology Verification Test Scale 18

 3.2.2 Other Test Factors 18

 3.2.3 Limitations to Proposed Verification Testing 19

 3.2.4 Statistical Verification Test Design Considerations 21

 3.3 Emission Measurements 23

 3.3.1 Emission Measurements for Total Volatile Organic Compounds
 (VOCs) 29

 3.3.2 Emission Measurements for Total Non-Methane VOCs 30

 3.3.3 Emission Measurements for Speciated VOCs 31

 3.3.4 Emission Measurements for VOC Removal Efficiency 32

 3.3.5 Emission Measurements for By-products 33

 3.3.6 Effluent Measurements for VOC (Removal Efficiency) 34

 3.3.7 Emission and Effluent Measurements for Microorganisms 35

 3.4 Sampling 36

4.0 REQUIREMENTS FOR TEST/QA PLAN 36

 4.1 Quality Management 36

 4.2 Quality Assurance (QA) 36

 4.3 Additional Requirements to be Included in the Test/QA Plan 37

| | | |
|------|--|-----|
| 5.0 | REPORTING AND DOCUMENTATION REQUIREMENTS | 38 |
| 5.1 | Data Reduction | 38 |
| 5.2 | Reports | 39 |
| 6.0 | DISSEMINATION OF ETV REPORTS AND VERIFICATION STATEMENTS | 40 |
| 7.0 | LIMITATIONS ON TESTING AND REPORTING | 40 |
| 8.0 | ASSESSMENT AND RESPONSE | 41 |
| 8.1 | Assessment Types | 41 |
| 8.2 | Assessment Frequency | 42 |
| 8.3 | Response to Assessment | 42 |
| 9.0 | SAFETY MEASURES | 43 |
| 9.1 | Safety Responsibilities | 43 |
| 9.2 | Safety Program | 43 |
| 9.3 | Safety Requirements | 43 |
| 10.0 | REFERENCES | 44 |
| | APPENDIX A EXAMPLE VERIFICATION STATEMENT | A-1 |

FIGURES

| | | |
|-----------|--|----|
| Figure 1. | Bioreaction System with Monitoring Sites Indicated (G for gaseous, L for liquid) | 13 |
| Figure 2. | Organizational Structure for Bioreaction System Verification Testing | 17 |
| Figure 3. | Confidence Interval as a Function of Number of Test Runs | 22 |

TABLES

| | | |
|----------|---|----|
| Table 1. | Example Measured Parameters and Methods | 24 |
|----------|---|----|

ACRONYMS AND ABBREVIATIONS

| | |
|------------------|--|
| ADQ | audit of data quality |
| ANSI | American National Standards Institute |
| APCT | Air pollution control technology |
| APCTVC | Air Pollution Control Technology Verification Center |
| APHA | American Public Health Association |
| ASTM | American Society for Testing and Materials |
| CI | confidence interval |
| CL | confidence limit |
| CO ₂ | carbon dioxide |
| DQO | data quality objective |
| ECD | electron capture detectors |
| EPA | U.S. Environmental Protection Agency |
| ETV | Environmental Technology Verification (EPA Program) |
| FID | flame ionization detector |
| FTIR | Fourier transform infrared |
| GC | gas chromatography |
| GC/MS | gas chromatography/mass spectrometry |
| GVP | generic verification protocol |
| H ₂ O | water |
| HAPs | hazardous air pollutants |
| HC | hydrocarbons |
| IR | infrared |
| MRI | Midwest Research Institute |
| NO _x | nitrogen oxides |
| ORD | Office of Research and Development (EPA) |
| PEA | performance evaluation audit |
| PID | photoionization detector |

(continued)

ACRONYMS AND ABBREVIATIONS (continued)

| | |
|-------|---------------------------------|
| ppb | parts per billion |
| ppmv | parts per million by volume |
| PQL | practical quantitation limit |
| PTFE | polytetrafluoroethylene |
| QA | quality assurance |
| QC | quality control |
| QMP | quality management plan |
| RTI | Research Triangle Institute |
| SA | surveillance audit |
| SAC | Stakeholders Advisory Committee |
| SI | Standard International |
| SOPs | standard operating procedures |
| THC | total hydrocarbon analyzer |
| TO | total organics |
| TOC | total organics compound |
| T/QAP | test/quality assurance plan |
| TSA | technical systems audit |
| VOCs | volatile organic compounds |
| VOST | volatile organic sampling train |
| VR | verification report |
| VS | verification statement |

1.0 INTRODUCTION

1.1 Environmental Technology Verification

The U.S. Environmental Protection Agency (EPA), through its Office of Research and Development (ORD), has instituted the Environmental Technology Verification (ETV) Program to verify the performance of innovative or improved technical solutions to problems that threaten human health or the environment. The EPA created the ETV Program to accelerate the entrance of new and improved environmental technologies into the domestic and international marketplaces. It is a voluntary, non-regulatory program. Its goal is to verify the environmental performance characteristics of commercial-ready technologies through the evaluation of objective and quality-assured data so that potential purchasers and permittees are provided with an independent and credible assessment of what they are buying and permitting.

The ETV Program does not conduct technology research or development. ETV test results are always publicly available, and the applicants are strongly encouraged to ensure, prior to beginning an ETV test, that they are satisfied with the performance of their technologies. Within the ETV Program, this state of development is characterized as “commercial-ready,” and the ETV test is conducted on production units or prototypes having the major characteristics of production units.

The provision of high-quality performance data on fully-developed commercial technology encourages more rapid implementation of those technologies and consequent protection of the environment with better or less expensive approaches. The ETV Program is conducted by six ETV centers and one pilot that span the breadth of environmental technologies.

1.2 Air Pollution Control Technology Verification Center

The EPA’s partner in the Air Pollution Control Technology Verification Center (APCTVC) is the Research Triangle Institute (RTI), a not-for-profit contract research organization with headquarters in Research Triangle Park, NC. The APCTVC verifies the performance of commercial-ready technologies used to control air pollutant emissions. The emphasis of the APCTVC is currently on technologies for controlling particulate matter, volatile organic compounds (VOCs), nitrogen oxides (NO_x), and hazardous air pollutants (HAPs) from both mobile and stationary sources. The activities of the APCTVC are conducted with the assistance of stakeholders from various interested parties. Overall APCTVC guidance is provided by the Stakeholders Advisory Committee (SAC), while the detailed development of individual technology ETV protocols is conducted with input from technical panels focused on each technology area.

The APCTVC develops generic verification protocols (GVPs) and specific test/quality assurance plans (T/QAPs), conducts independent testing of technologies, and prepares ETV test reports and statements for broad dissemination. Testing costs are ultimately borne by the technology applicants, although initial tests within a given technology area may be partially supported with ETV Program funds.

1.3 Bioreaction Air Pollution Control Technology

Bioreaction is a general term applied to the conversion of gas-phase chemical compounds (i.e., contaminants) to the common degradation products of carbon dioxide, water, organic biomass, and inorganic salts. Gas-phase biological reactors utilize metabolic reactions to treat contaminated air. The process relies on two primary fundamental mechanisms— sorption and biodegradation. The contaminants are sorbed from the gas or air stream to an aqueous phase where microbial attack occurs.

Technologies considered to be forms of bioreaction systems include biofilters, bioreactors, bioscrubbers, biotrickling filters, and soil beds. While all of these operate based on the same fundamental mechanisms of contaminant sorption and biodegradation, they have different design and operating/control parameters, operational flexibility, and performance characteristics. There are three basic types of process design:

- Biofilters/bioreactors – packed bed reactor with compost, peat, soil, or other bio-active media, and external humidification;
- Biotrickling filters – packed bed reactor with moving liquid phase (recycled water stream), and inert media; and
- Bioscrubbers – two-stage system with packed column absorption and a separate liquid phase bioreactor.

Bioreaction systems may be an emerging technology for the control of VOCs. Bioreaction technologies have been used extensively for over 40 years in the U.S. and Europe for the control of odors for wastewater treatment facilities, rendering plants, and other odor-producing facilities. During the past few years, this technology has been increasingly used in the U.S. for treating high volume, low concentration air streams. Numerous research studies are being conducted to characterize its suitability for a wide variety of VOC emission control applications. Bioreaction systems are an attractive alternative to conventional air-pollution-control technologies (e.g., thermal oxidizers, catalytic oxidizers, carbon adsorption systems, wet-scrubbers) for several reasons:

- Removal efficiencies of greater than 90 percent have been demonstrated for many of the more common air pollutants, including some of those listed by EPA as HAPs;
- Due to lower operating costs, bioreaction systems may offer economic advantages over conventional air pollution control technologies, especially in applications where the air stream contains contaminants at relatively low concentrations and moderate to high flow rates [Note: the capital cost of bioreaction system technology is highly application specific.]; and
- Operation does not require large quantities of energy (e.g., no fossil fuels are required) and produces relatively low-volume, low toxicity waste streams with no secondary air pollutants such as NO_x formed.

However, bioreaction systems do not typically achieve the very high (e.g., ≥ 99 percent) destruction and removal efficiencies demonstrated by conventional technologies that do not depend on microorganisms.

Also, because there is a general lack of U.S. application experience, bioreaction technology is not well understood either by facility owners/operators or federal and state regulators. For these reasons, the APCTVC's SAC recommended bioreaction system control technologies for VOC compound emissions as a priority for verification.

1.4 The APCTVC Bioreaction System Control Technology Verification

RTI assembled a technical panel of representatives of federal and state air pollution control agencies, equipment manufacturers and vendors, facility operators, consultants, and trade associations with expertise in VOC measurement and control. The role of the Technical Panel was to provide advice and consultation to the APCTVC in preparing this GVP for control devices that utilize biodegradation as a mechanism for the removal and destruction of vapor phase organic compounds. The Technical Panel identified and discussed issues related to measuring the performance of vapor-phase bioreaction system control technologies.

1.5 Quality Management Documents

Management and testing in the APCTVC are performed in accordance with procedures and protocols defined by the following series of quality management documents:

1. The EPA's ETV Program Quality Management Plan (QMP) (EPA, 2003 or the quality and management plan current at the time of testing),
2. The APCTVC's Verification Testing of Air Pollution Control Technology – Quality Management Plan (QMP) (RTI, 1998 or the QMP current at the time of testing),
3. The Generic Verification Protocol for Bioreaction System Control Technologies for Volatile Organic Compound Emissions (this document), and
4. The T/QAP prepared for each specific test or group of tests.

EPA's ETV QMP lays out the definitions, procedures, processes, inter-organizational relationships, and outputs that will ensure the quality of both the data and the programmatic elements of the ETV Program. Part A of the ETV QMP contains the specifications and guidelines that are applicable to common or routine quality management functions and activities necessary to support the ETV Program. Part B of the ETV QMP contains the specifications and guidelines that apply to test-specific environmental activities involving the generation, collection, analysis, evaluation, and reporting of test data.

APCTVC's QMP describes the quality systems in place for the overall APCTVC. It was prepared by RTI and approved by EPA. Among other quality management items, it defines what must be covered in the GVPs and T/QAP for technologies undergoing ETV testing.

Generic Verification Protocols (GVPs) are prepared to describe the general procedures to be used for testing a type of technology and define the critical data quality objectives (critical DQOs). This GVP for bioreaction system control technologies was written by the APCTVC with input from a technical panel and approved by EPA.

A Test/QA Plan (T/QAP) is prepared for each test or group of tests involving the particular technology or product being verified. The T/QAP describes, in detail, how the test organization will implement and meet the requirements of the GVP. The T/QAP also sets DQOs for any planned measurements that were not set in the GVP. The T/QAP addresses issues such as the test organization's management structure, the test schedule, test procedures and documentation, analytical methods, record keeping requirements, and instrument calibration and traceability, and it specifies the QA and quality control (QC) requirements for obtaining ETV data of sufficient quantity and quality to satisfy the DQOs of the GVP. Section 4 of this GVP addresses requirements for the T/QAP.

2.0 OBJECTIVE, SCOPE, AND VERIFICATION FACTORS

2.1 Objective

The overall objective of this GVP is to verify, with appropriate and documented data quality, the performance of commercially ready bioreaction system control technologies that are applied to organic compound emission (e.g., VOCs or HAPs) sources. This GVP establishes which parameters within bioreaction system control technology operations will be tested to verify their performance or VOC removal efficiency. This GVP addresses the requirements for technology submission, outlines the test conditions and procedures to be used, states the DQOs for verification testing, and specifies reporting requirements. The control technologies will be verified within a specified range of applicability, and verification reports and statements will be produced for dissemination to the public.

2.2 Scope

APCTVC testing will be performed on add-on "closed-system" bioreaction-based control devices that are applied to stationary emission sources of organic air emissions (referred to as VOCs throughout this GVP). The verification tests will gather information and data for evaluating the performance of bioreaction system technologies. The scope will, in most cases, cover two principal study questions:

1. What is the performance of the technology (e.g., VOC removal efficiency in percent and/or VOC emission concentration in ppmv)?
2. What are the test conditions (a range) over which the performance is measured (e.g., gas flow rate, inlet VOC concentration, and percent of rated or design capacity)?

Data may also be gathered to evaluate the technologies' associated environmental impacts and resource requirements; in these cases, the study would attempt to answer the following questions:

3. What are the associated environmental impacts of operating the technology within the specified range (e.g., are cross-media pollutant emission/effluent or by-product air emissions generated, or are any potentially harmful microbes, pathogens, entrained in the exhaust gas or liquid effluent)?
4. What are the resources associated with operating the technology within the specified range (e.g., in terms of energy use, waste disposal requirements)?

Question 1 is the critical question for this verification, and thus the associated performance measurements are the critical measurements. In establishing the DQOs for the critical measurements associated with Question 1, the two factors (or conditions) that contribute to the final performance variability are acknowledged: (i) the uncertainty (or variability) of the reported measurements, and (ii) the variability of the process (i.e., uncontrolled gas stream) parameters. To allow consideration of differences in the level (or amount) of “process variability” as well as “measurement variability,” the data quality objectives (DQOs) for both variability factors (or conditions) are addressed separately in this GVP. The DQOs for Question 1 are specified in Section 2.5 of this protocol and apply to VOC concentration testing performed under the authority of this GVP. Measurements to answer Question 2 require sufficient accuracy to allow subjective evaluation of the performance envelope, but are not critical measurements. These may utilize available values (e.g., plant instrumentation), and, thus, specific DQOs are not included in this generic verification protocol. However, high quality measurements are important because these measurements will establish the boundaries of the envelope within which performance is being verified. Questions 3 and 4 are non-critical and may be answered based on estimates and available instrumentation; these study questions are particularly relevant to bioreaction system technologies because they provide a basis for further evaluating the overall environmental contribution of the technology. Objectives for measurements addressing Questions 2, 3 and 4 will be consistent with QC requirements in specified methods, thus providing data of known quality.

2.3 Products to be Tested

- **Definition of technology.** Any commercially ready, closed system control technology device which uses microbes (i.e., biodegradation) to control a gas stream containing VOCs could be included for testing using this GVP under the general term of bioreaction system technology. This would include enclosed biofilters, bioreactors, bioscrubbers, and biotrickling filters. Open systems, such as pits or ponds, will not be evaluated or tested using this GVP.

2.4 Verification Parameters

- **Measurements.** The evaluation criterion for the technology is performance or efficiency in removing organics (i.e., VOCs) from the gas stream. Two primary measures may be used to evaluate VOC control technology performance. One measure is the emission concentration in parts per million by volume (ppmv). The other is the mass removal efficiency. The technical panel advised that **VOC removal efficiency** (defined in Section 5.1) is the performance measure of primary interest. VOC exit gas concentration is included in this protocol as an additional measure of interest for very low VOC concentration applications (i.e., <100 ppmv) where removal efficiency or percent reduction may not be an appropriate measure of performance or as indicative of treatment benefit as outlet concentration. To determine performance in terms of removal efficiency, the critical measurements are organic or VOC mass at all input and output points. Total flow (volume per unit time) and VOC loading (concentration) measures are needed. Both gas and liquid streams should be included to complete a mass balance and account for any VOC removed by mechanisms other than biodegradation. Supporting measurements include performance measures that could affect efficiency, including but not limited to air temperature, pressure drop, humidity, and water

input (volume, concentration of organics). Other information may also need to be recorded, such as manufacturing cycle and indication of performance or process stability. Vendors should provide ranges for the primary organic constituents in the uncontrolled gas stream and the critical process and control device operating parameters, as well as expected operating rates.

- **Chemicals to be tested.** VOC removal efficiency is reported in terms of total VOC reduction (inlet versus outlet). The general term VOCs (as used in this document) includes a wide range of chemical constituents, and there are several test methods available to measure them. No one test method is appropriate for all industries or applications for bioreaction system technology; therefore, this GVP identifies multiple acceptable test methods and establishes some basic criteria for their use. (Note: the various test methods do measure different variables: total carbon, propane equivalents, speciated organics.) Depending on the test method selected for use, organic carbon or a surrogate organic concentration (e.g., as propane equivalent) or individually speciated organics are reported, as appropriate to the method used. Removal efficiency by individual chemical constituent or compound (i.e., percent reduction) can also be reported if appropriate data collection is included in the T/QAP and relevant data of acceptable quality are gathered during the verification test. Each T/QAP will identify the specific chemical(s), and associated method(s), for which testing is to be performed.

- **Monitoring points.** Figure 1 provides a representative schematic view of a typical bioreaction system control device. The number of input and output points may vary with different technology system types, but the idea is that all input or output points should be measured (gases and liquids) so that a mass balance can be made to adequately characterize the system in the performance determination. There should be monitoring after the pre-treatment and humidification stages when they are external to the system. However, for some systems, the pre-treatment and humidification control are included internally; so monitoring at these locations is not appropriate for these type systems. Location of the monitoring points (and the length of the test runs) must be structured so as to take any VOC sinks (e.g., activated carbon) into consideration. There should be a test point after load equalization. Each T/QAP will identify the specific monitoring points for a specific site/technology for which testing is to be performed.

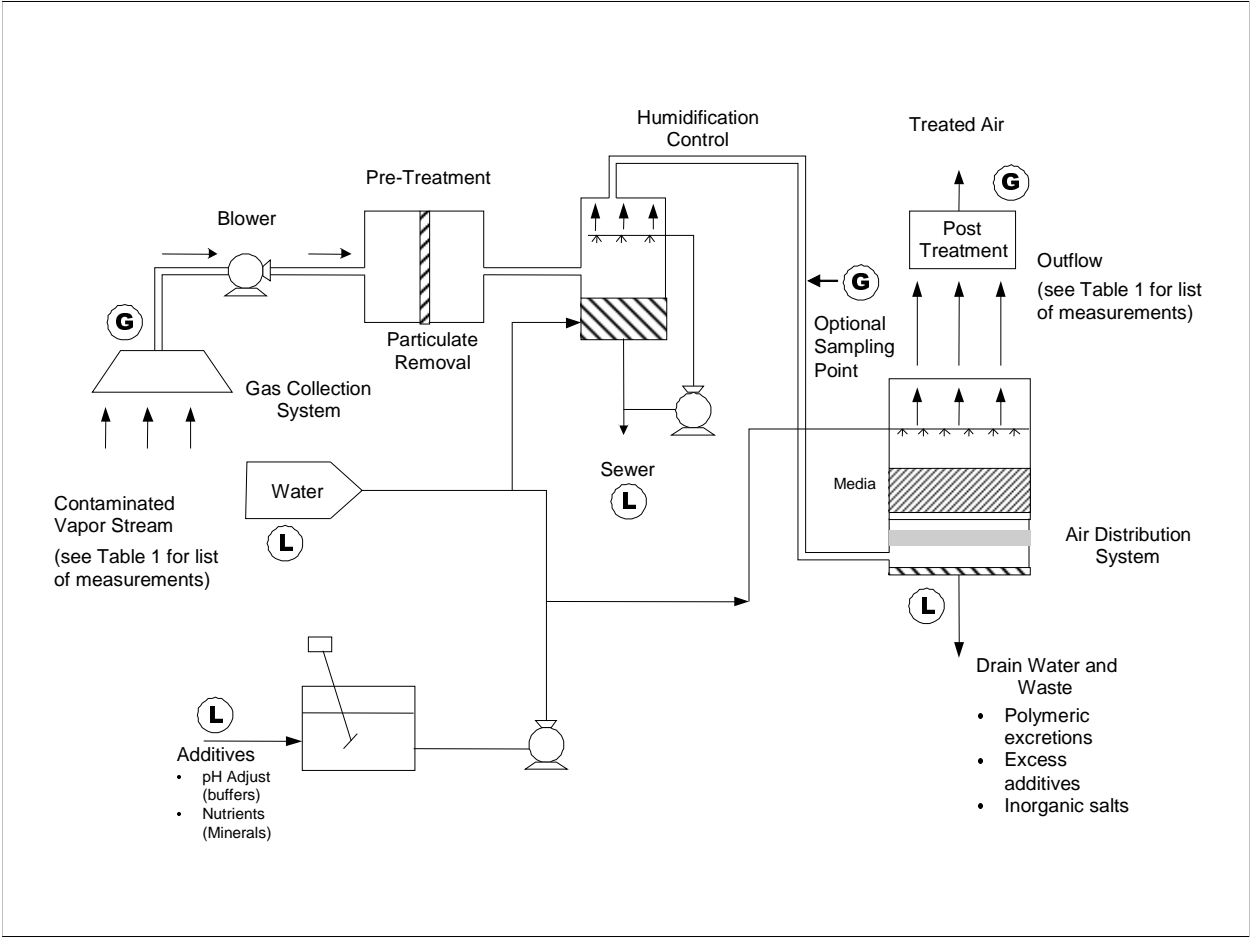

**Figure 1. Bioreaction System with Monitoring Sites Indicated
(G for gaseous, L for liquid)**

2.5 Data Quality Objectives (DQOs)

The two critical performance measures for VOC control technologies, allowed by this protocol because of the wide range of applications for bioreaction technologies, are (i) control device VOC emission concentration, and (ii) VOC mass removal efficiency (a calculated value). As is described in Sections 3 through 5, the performance of a VOC control technology (principal study Question 1) will be verified using an approach designed to achieve the DQOs within the performance range tested. As previously noted, two conditions contribute to the variability in the reported technology performance (Question 1): measurement uncertainty and process variability. The DQOs specified in this section address both conditions and apply to all testing conducted under this GVP; the site/technology specific T/QAP also will address process variability and its related DQO.

The measurement DQOs for the VOC concentration require that the T/QAP specify measurement methods, together with QA/QC procedures, sufficient to allow determination of the technology's overall inlet and exit gas VOC concentration within ± 10 percent of the mean measured emission concentration (above 3 ppmv). The attainment of this DQO is to be estimated using method-specific calibration performance. It is expected that measurement bias will be effectively removed by use of suitable reference materials, leaving only imprecision about the mean as an issue. For example, method or measurement variability can be quantified for comparison to the DQOs when the measurement system(s) encounters known variables that are essentially time-invariant, such as with calibration or reference samples where the VOC gas stream to the analyzer has a controlled, constant flow rate and known VOC composition and concentration.

Process operations that generate or emit VOC containing gas streams, amenable to control using bioreactors, are inherently variable under normal operating conditions (e.g., fluctuations in VOC concentration are routine and may or may not be related to operating conditions). This process operating condition implies variability requiring statistical analysis of the control device exhaust gas stream VOC concentration measurements. Therefore, the DQOs for process variability relate to characterizing that VOC concentration variation during the verification test which is communicated in the verification report. The process variation DQO for control device exhaust gas VOC measurements is $\pm 20\%$ for concentrations above 3 ppmv. If the technology applicant anticipates the particular application will yield a controlled VOC concentration variation outside this limit, the process variation DQO must be addressed in the T/QAP. Section 3.2.4 of this GVP outlines the DQO considerations to be included in the T/QAP.

Note: Constraints on the ETV process require that the test cost be commensurate with the benefit derived from the verification. For this reason, the DQOs specified in this draft protocol must be considered tentative until field data are available to allow evaluation of the approach taken.

The DQO is to be computed as the half-width of the 95 percent confidence interval of the mean divided by the mean (or, equivalently, as the product of the standard error of the mean and the appropriate student's-t value divided by the mean). This means that 95 percent of the time, when the DQO is met, the actual concentration value will be within a fixed percentage of the mean measured value. The VOC emission concentration will be measured using one or more of the EPA Reference Methods noted in Section 3.3, which are the reference standards for VOC emissions. All measurements apply at the operating conditions being verified.

For VOC removal efficiency measurements, the T/QAP will utilize the DQOs above for VOC inlet and exhaust gas concentrations and a DQO of $\pm 3\%$ for inlet and exhaust gas volumetric flow rates. The flow rate will be measured using the EPA reference methods noted in Section 3.3, which are the reference standards for gas volumetric flow rate. Separate DQOs will be specified in the T/QAP for the measurement of any inlet and effluent (liquid) VOC concentrations and flows.

Removal efficiency is calculated from the inlet and outlet VOC mass emission rates. Therefore, the critical measurements are VOC mass at all inputs and outlets of the bioreaction system. Both gas and liquid streams must be accounted for in the removal efficiency calculation. For those systems where there is no significant liquid effluent stream, the VOC mass emission rates, in turn, are proportional to the product of the measured gaseous concentrations and associated volumetric flow rates. Thus, in this case, DQOs for the measured values of gaseous concentration and volumetric flow rate provide a quality objective for removal efficiency.

For those systems with liquid effluent streams, total VOC concentration or the concentrations of individual VOC's will be measured using one of the EPA reference methods (i.e., Method 9060 for total VOCs or one or more of the speciation methods noted in Section 3.3 for individual VOCs). Each method contains a list of analytes for which the method has been validated and estimates of the accuracy and precision of the method for each analyte. Depending on the composition and complexity of the VOC mixture in the feed stream to the biofilter, analysis of liquid effluent samples by more than one method may be required to measure all target VOCs.

Should the verification test be conducted and the GVP DQOs not be met, for example due to excessive measurement variability, the APCTVC will present the data to the vendor and discuss the relative merit of various options. The two primary options will be either to continue the test to obtain additional data, with resulting increases in cost, or to terminate the test and report the data obtained.

The uncertainties outlined above require that the DQOs expressed in this draft generic verification protocol be reviewed following completion of the first tests and analysis of the results. The DQOs may need to be revised for the final version of this document. Specific DQOs are included in this GVP for critical measurements addressing principal study Question 1. Specific DQOs will also be included in each T/QAP for all measurements addressing principal study Question 2.

The quality of measurements for principal study Questions 3 and 4 will be addressed through numeric specifications when possible or through qualitative discussions when numeric estimates are not possible. Specific measurement quality objectives may vary between different T/QAPs written to conform to this GVP.

While not critical, accurate measurement of test conditions such as temperature, humidity, pressure drop, and percent of rated capacity is important because the measurements set the boundaries within which the verification applies. Other information may need to be recorded, such as energy consumption, manufacturing cycle, or some indicator of process stability. Plant instrumentation may be used to make these measurements provided it is found to be adequate and has a current calibration. Parallel calibrated instrumentation should be used whenever practical. Measurement quality objectives will be set after inspection of the test site and specified in the T/QAP. The potential for measurement bias should be evaluated by inspection and experience. QC procedures and technical assessments will evaluate

measurement bias during verification testing for those measurement parameters where the potential for bias has been identified.

3.0 TEST PROGRAM

3.1 Verification Testing Responsibilities

This ETV program is conducted by the APCTVC under the sponsorship of the EPA-ORD and with the participation of technology applicants. The APCTVC is operated under a cooperative agreement by RTI, EPA's ETV partner. RTI's role as ETV partner is to provide technical and administrative leadership and either conduct or manage the conduct of ETV testing and reporting. Various subcontractors have roles in the APCTVC under RTI's management. ETV tests are conducted by qualified testing organizations overseen by RTI. In addition, T/QAPs are prepared by the testing organizations to meet the requirements of the GVP. The organizations involved in the verification testing of bioreaction air pollution control technologies are the EPA, RTI, the testing organization, and the bioreaction system technology applicant. Figure 2 presents the organizational structure that illustrates the relationships and roles of the various participating organizations.

The primary responsibilities for each organization involved in the test program are listed below.

1. The EPA-ORD, following its procedures for ETV, reviews and approves GVPs, T/QAPs, ETV reports and statements, and conducts QA audits.
2. The APCTVC prepares the GVPs, provides oversight of and audits the test organization, provides a template for T/QAPs, reviews and approves the ETV test reports, and drafts the ETV reports (VR) and verification statements (VS).
3. The test organization prepares the T/QAPs in accordance with the GVPs, coordinates test details and schedules with the applicants, conducts the tests, and prepares and revises draft ETV test reports. The test organization QA staff is responsible for conducting internal QA on test results and reports.
4. EPA-ORD and/or APCTVC QA staff, at their discretion and in accordance with requirements of the ETV QMP and APCTVC QMP, will conduct assessments of the test organization's technical and quality systems.

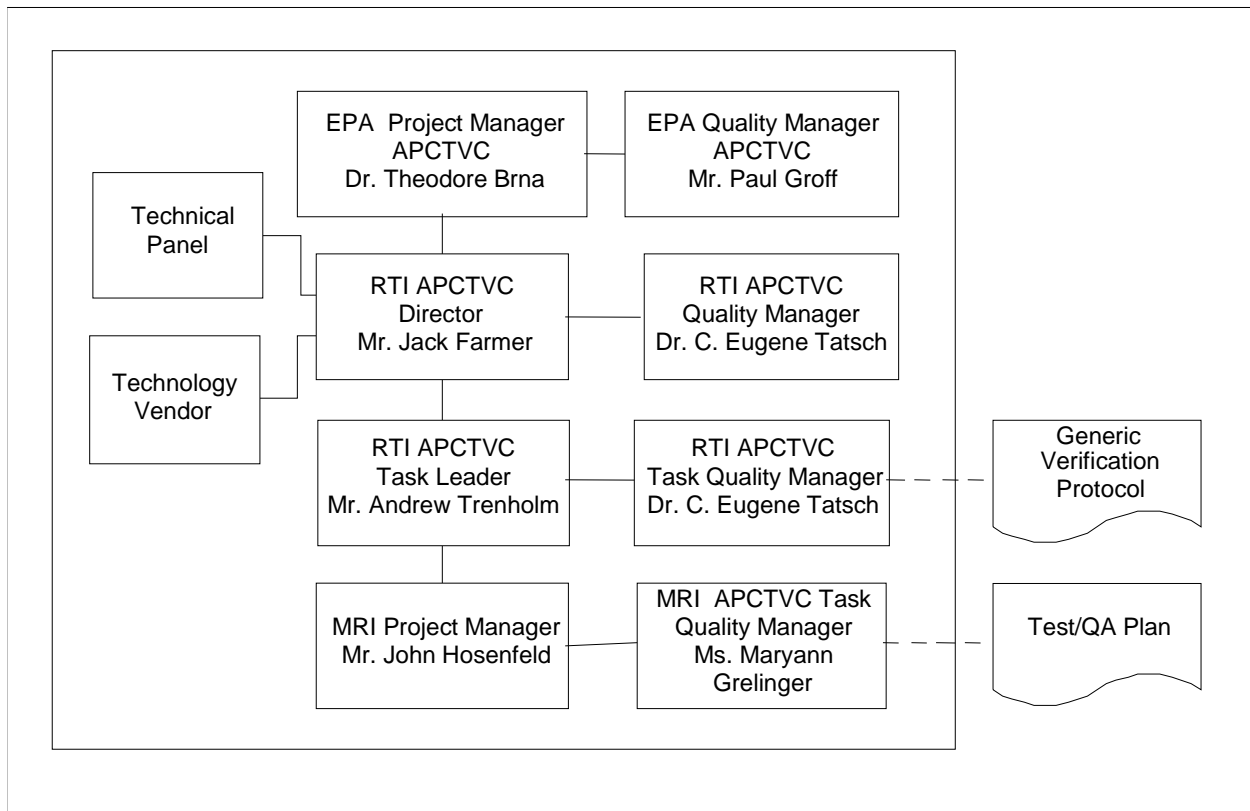

Figure 2. Organizational Structure for Bioreaction System Verification Testing

5. The technology applicant provides complete, commercial-ready equipment for ETV testing; provides logistical and technical support, as required; and assists the test organization with operation and monitoring of the equipment during the ETV testing. The applicant's responsibilities are defined by a contract or letter of agreement with RTI.

3.2 Test Design

The primary objective of verification testing is to evaluate bioreaction-based air pollution control technology for its effectiveness at removal of VOCs from the inlet gas stream. While the ETV program is not regulatory and an ETV test is not a compliance test, measurements that relate directly to regulations are of interest to most manufacturers/vendors, buyers/users, and agency permit writers. In addition, the environmental impacts of operating the technology (e.g., by-product pollutants emitted) and energy and other resource requirements are also of importance and will be evaluated as a part of the verification test. The T/QAP will contain appropriate provisions that address data collection related to these performance parameters.

All verification tests will be conducted during defined test periods and under operating conditions directly specified in the T/QAP. Both the process and control technology operating conditions used during the verification testing will be established in the T/QAP and documented as part of the

verification test procedure. Detailed descriptions and a schedule for all the preparation for, conduct of, and reporting related to the verification test will be given in the T/QAP.

In general, a verification test must be designed to determine the performance of an air pollution control technology (APCT) in specified terms and of known quality, and to define the applicability bounds of the verification. Four major factors to consider in the test design are:

1. The scale of the technology verification test,
2. Control equipment operation and process operating conditions during the test,
3. Sample locations and sampling and measurement methods, and
4. The number, frequency, and duration of measurements.

3.2.1 Technology Verification Test Scale

The possible options for technology verification test scale are a full-scale installation, a pilot-scale (transportable) device operated on a slipstream at a full-scale facility, and a pilot-scale device operated at a controlled laboratory facility (e.g., one manufacturer has offered its laboratory bioreactor system for use). In this context, pilot-scale is taken to mean a small, transportable implementation of the technology that scales to its intended maximum size following established engineering scaling factors, or a single module of a technology that scales by adding additional modules. A full-scale facility will provide a test that best matches real world conditions but may offer limited flexibility to test the device under as wide a range of conditions as a vendor may desire to be verified. A laboratory facility provides the most control of source and device operating conditions which allow the test to cover the broadest range of conditions but is less representative of real world conditions. A pilot device on a slipstream at a full-scale facility provides a compromise between the two other approaches.

Decisions regarding the acceptability of pilot-scale units will be made by the APCTVC program, which must be convinced that the verification is applicable to its proposed use and the technology is commercially ready. Factors that will influence the choice of verification scale include:

- The scale and nature of the specific equipment available for testing. (This may be different for each verified technology),
- The desire to test an actual versus a simulated pollutant source,
- The need to control the source to support testing under varied conditions,
- Test costs, and
- Practical source testing constraints.

3.2.2 Other Test Factors

The other three major factors listed above — technology operation, measurement methods, and number and type of measurements — must also be considered in the test design. They are also the sources of variability that affect the level of uncertainty in the verification results.

Control technology operation refers to the conditions at which the actual tested equipment is operated during the technology verification test. The range of these operating conditions determines the breadth of applicability for the verification test and hence of the verification statement. Key operating parameters, along with their expected range of values for the desired applications, must be identified and included in the test design.

Sample collection and measurement methods affect the data precision and, consequently, the data quality and applicability range of the verification statement. The VOC test method(s) chosen for use will be the appropriate EPA reference method(s) for the technology based on consideration of the bioreaction system design and its operating characteristics (e.g., the chemical makeup of the VOC constituents in the gas stream and the presence of any VOC sinks or adsorbent in the system). Measurements of other parameters will also follow accepted testing practice standards whenever available. Measurement methods proposed for use in VOC control technology verification testing are discussed later in this section. These methods will be used unless field circumstances require substitution of alternate methods; such substitution will be clearly described and explained in the T/QAP and in the test report.

Based on the above considerations, the number and length of test runs are set in the T/QAP as expected to meet the DQO requirements in Section 2.5. Setting the number and length of test runs is often a trade-off between test cost and the quantity of data desired to perform statistical analyses. These are discussed further below in Sections 3.2.3 and 3.2.4.

3.2.3 Limitations to Proposed Verification Testing

Sources of potential variability in a verification result that will not be addressed for reasons of cost and practical difficulty are:

- Change in performance over time (The verification will address performance only during a one-time test); and
- Performance differences between different installations of the VOC control technology being verified.

Also, bioreaction systems are typically operated at specific conditions to maintain continued viability of the microorganisms; significant variation in the operating conditions of the process and the control device may not be possible. Specific conditions that require control may include temperature, VOC concentration, flow rate, moisture content, bioreactor pressure drop. With these limitations, varying operating conditions for the sake of defining a wide range of applicability for the verification test and the verification statement is difficult. Therefore, the verification test (and T/QAP) will be based on multiple test runs at a chosen (predetermined) set of operational conditions.

Short-term performance monitoring provides only a “snapshot” of the process performance at a given time and under a given set of operating conditions. Long-term operational effects such as bed plugging or poisoning, packing acidification, and nutrient shortage exist in bioreaction systems, and these conditions impact control device performance. Typically, these conditions usually occur after months of operation and would not likely occur or be detected in a short-term GVP test. However, should these

types of problems arise during conventional short-term testing, a significant effect on pollutant removal performance would likely be observed, and their occurrence would be noted in the test report.

This GVP is not designed in any way to address long-term operational changes or concerns and their impact on overall control device performance. There are no provisions in the GVP or in the performance reports to account for control device downtime over the long-term due to infrequent operational conditions such as media changes and recharges.

As previously noted, controlling the cost of verification testing is important to the viability of the APCTVC. The VOC Technical Panel has determined that the cost of a field test program that is about one week in duration leads to an overall verification test whose cost is reasonable, given the value of that test to the manufacturer. Based on field test experience, the number of independent, steady-state test runs of VOC control equipment that can be conducted within a week of field time (i.e., three test days) will vary based on the averaging time selected for the test period. It is estimated to be a minimum of three test runs (i.e., one eight-hour test run per day for three test days) and will increase as the test run averaging time decreases. However, this GVP leaves open the exact duration (i.e., sampling or averaging period) and number of test runs that can be used to characterize control device performance. These are to be established in the T/QAP for the particular technology test.

With regard to process operations, this GVP is not limited to measuring control device performance when the system is only in a steady-state mode. If there are variations in the process system served by the control device, measurements should be made during a whole process cycle, if possible, to characterize technology performance during each cyclic period or segment as well as over the entire process cycle. Conditions that could cause variations in the control device performance and that are related to process and/or technology operations include:

- Concentration fluctuations,
- Carbon (sink) cycle, including saturation,
- Manufacturing cycle (8, 12, or 24 hours per day, number of days per week), plant shutdowns, and
- Media replacement in the bioreaction system.

For example, if a five-day test were run for eight hours each day, there is concern that test runs during days two, three, and four would not accurately represent or adequately characterize the first and last day's performance at a plant that was not running continuously. A plant running 7 days/24 hours has an emission profile that is very different from one running 5 days/8 hours. Thus, if the facility operated on a five-day week, the first and last day's performance would generally look different from the other three days.

Continuous monitoring can assist in identifying periods with variations in the control device performance that are related to process or technology operations. For example, continuous monitors (i.e., Method 25A) on the air inlet and outlet would allow real-time monitoring of the stability of both the process gas stream and the bioreaction system, and could be used to determine an appropriate sampling

schedule. The sampling schemes/schedules for steady-state, cyclic, and episodic processes would be quite different; this consideration is to be addressed in the T/QAP for the specific technology and process operation undergoing verification testing under this GVP.

3.2.4 Statistical Verification Test Design Considerations

In general, an experimental test design is necessary to test the control technology under a set of predetermined field conditions. Such a design lays out the type and number of tests to be conducted under different sets of field-controllable test conditions that will exercise the technology over a range of operation within which performance will be verified. Operation outside that range may well be possible, but the verification statement will not apply. As mentioned previously in this section, the operation of bioreaction systems is unique in that certain operating conditions must be held relatively constant to maintain the viability of the microorganisms. For non-cyclic, steady-state process operations, it is assumed that no operating parameters will be varied during verification testing; thus, the test design will simply consist of replicate runs at nearly identical operating conditions. However, this GVP does not preclude verification testing that involves deliberate, planned variation of operating conditions (such as flow rate, temperature, or organic concentration) provided that these parameter variations are adequately addressed in the T/QAP for the technology. When the process (gas stream) cannot achieve/maintain stable, steady-state conditions, the operating parameters and test design will be defined in the T/QAP.

Considering the uniqueness and complexity of each technology-site application, a T/QAP will be developed that can reasonably be expected to generate an acceptable quantity and quality of data at an acceptable cost. This will include detailed specification of sampling locations, parameters, and determinative methods, and the anticipated number of replicate tests. The remainder of this section describes the recommended experimental design process for this GVP for those verification tests where the processes generating the emission stream are considered reasonably stable, continuous, steady-state operations. A statistical approach will be used, to the extent practical, to develop the design for each verification test conducted under this GVP when the characteristics (variations) of the process gas stream allows for meaningful statistical analysis. In the T/QAP, statistical experimental design techniques will be used to develop the most efficient test design that will provide the most information for the least number of test runs. As required by the DQOs in Section 2.5, the product of this test design will be the verified mean VOC emission concentration(s) or the verified mean VOC percent reduction and the 95 percent confidence interval of the mean for the specified performance measure operating range for a specified number of test runs.

The DQO for VOC emission concentration is met when the 95 percent confidence interval (CI) of the mean has the width specified (for process variability) in Section 2.5. The confidence interval for the outlet VOC level depends on several inputs: the inherent variability of the VOC measurement, the desired level of confidence, and the number of runs. Figure 3 illustrates how the half-width of the confidence interval about the mean VOC concentration varies with the number of test runs for three selected confidence levels (CL) within the expected test range. The VOC emission concentration mean is computed over all tests, thus including any uncontrollable process variability as well as the measurement system variability addressed in Section 2.5. Figure 3 sheds light on the question of how many test runs are likely to be sufficient to obtain a confidence interval for the mean concentration with a predetermined precision and confidence.

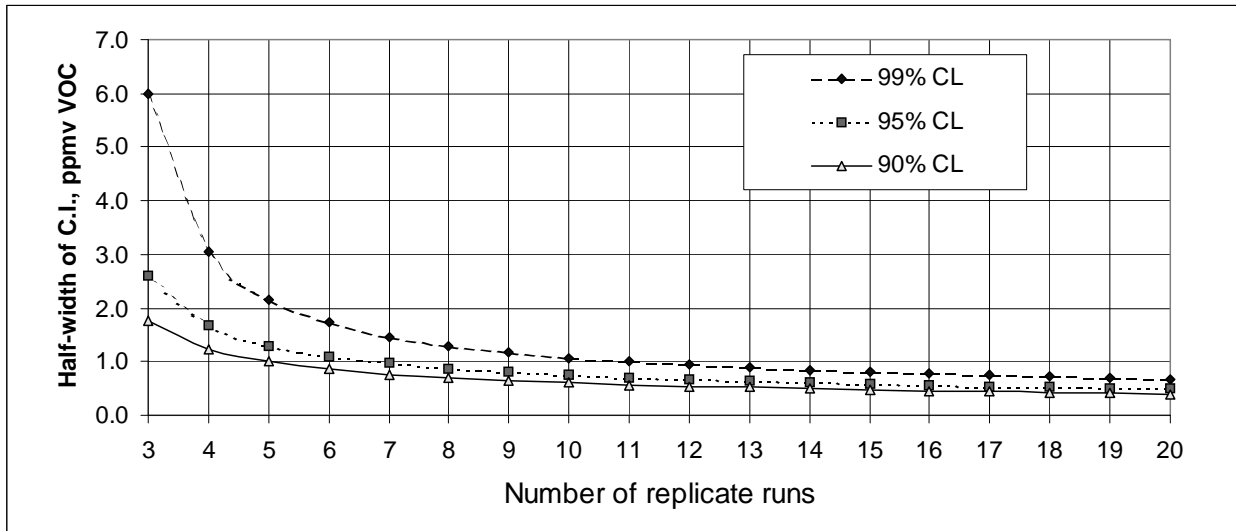

Figure 3. Confidence Interval as a Function of Number of Test Runs

The half-width is the range on either side of the mean outlet VOC level within which data points are estimated to fall for the specified confidence level. The figure is a reasonably realistic illustration of confidence intervals, based on an example EPA Method 25A data set as well as engineering judgement and test experience, that may be determined from a verification test. The assumptions made to compute the specific values in Figure 3 are that the true outlet VOC level is 3.2 ppmv and that the standard deviation of the VOC measurement is 1.04 ppmv. Note that the mean VOC concentration (3.2 ppmv) is very low, and the variability is approximately 33 percent; it is anticipated that the variability would be lower for higher means. The half-width of the confidence interval was then computed as the product of the standard deviation and the students-t value appropriate for the degrees of freedom (number of runs minus 1) divided by the square root of the number of tests.

Figure 3 shows the half-widths of confidence intervals for three different confidence levels. The upper line corresponds to a confidence level of 99 percent, the middle to 95 percent, and the lower line to 90 percent. For six test runs and a 95 percent confidence level, the half-width is estimated to be approximately 1.1 ppmv. The estimated 95 percent confidence interval for the outlet VOC level is 3.2 ± 1.1 ppmv (or from 2.1 to 4.3 ppmv) for this example, in which the estimated mean VOC emission concentration is 3.2 ppmv. For 12 test runs and a 95 percent confidence level, the half-width is estimated to be approximately 0.67 ppmv; the estimated 95 percent confidence interval for the outlet VOC level is 3.2 ± 0.67 ppmv (or from 2.5 to 3.9 ppmv). More than 12 test runs add incrementally little to the confidence of the verification.

For the VOC emission removal efficiency, these same statistical considerations will be applied to both the inlet and outlet VOC concentrations that are considered in the emission reduction calculation.

3.3 Emission Measurements

Measurement parameters to consider in the verification tests fall into four categories:

- Performance factors (e.g., measurements of inlet and outlet VOC concentration and flow rate),
- Associated impacts (e.g., VOC/HAP by-product emissions, wastewater discharge),
- Associated resource usage (e.g., total energy usage), and
- Test conditions (e.g., flow rate, percent of rated capacity, pressure drop, bed temperature, and ambient conditions).

Table 1 shows examples of parameters to be measured and the measurement method for each parameter (i.e., the standard test method for each parameter, if applicable) for the four categories. The individual T/QAP will identify the parameters to be measured for the specific technology being verified. There was general agreement among the Technical Panel that multiple test methods should be accepted and incorporated into the GVP with the results reported in a manner appropriate to the test method used. Both input and output results must be reported on the same basis (TOC, VOC, HC, total carbon, individual constituents, or other). Selection of a specific test method will be based on site-specific considerations which are to be discussed or documented in the T/QAP for the technology.

Table 1. Example Measured Parameters and Methods

| Factors to be Verified | Parameter to be Measured | Measurement Method | Comments |
|-------------------------------|---|--|---|
| Performance Factors | | | |
| VOC outlet emissions | VOC concentration | EPA Method 25A (40 CFR 60 App. A) | Universally used VOC emission test method |
| | VOC concentration | EPA Method 18 (40 CFR 60 App. A) - with Tedlar bag sampling | For sources with a few, known compounds amenable to GC analysis |
| Non-methane VOC emissions | VOC concentration | EPA Method 25A (40 CFR 60 App. A) and EPA Method 18 (40 CFR 60 App. A) for methane | |
| Speciated VOC emissions | Compound concentration | EPA Method 18 (40 CFR 60 App. A) | |
| | | EPA Method 320 (40 CFR 63 App. A) | |
| | | Portable Mass Spectrometer | |
| VOC removal efficiency | Inlet/outlet stack gas volumetric flow rate | EPA Methods 2, 2A, 2C, or 2D for flow rate; Method 4 for moisture (40 CFR 60 App. A) | VOC mass emission rate = concentration times flow rate |
| | Inlet/outlet VOC concentration | Use methods discussed above at both the inlet and outlet | See above |

(continued)

Table 1. (continued)

| Factors to be Verified | Parameter to be Measured | Measurement Method | Comments |
|------------------------------|----------------------------|--|--|
| Associated Impacts | | | |
| Wastewater & other effluents | VOC concentration | Method 9060 (EPA's SW-846), if no interfering species present EPA Method 25D Method(s) validated for specific target VOCs in water: 40 CFR 136 App. A; Method 8260 | Method 9060 may not be adequate for evaluation of VOC exiting the system via the reactor drain; a method that measures specific organic compounds is needed to account for organics introduced to the system or microbial excretions in the drain effluent If one or more other methods are used, each VOC measured must be on the list of validated analytes for the chosen method |
| | Concentration of acids | ASTM E70-97 pH meter | ASTM D1067-92 may be an acceptable alternative; EPA SW846, Method 9040B |
| | Flow rate | Water flow meter | Orifice plate, magnetic flow meter, manual gravimetric or volumetric measurement |
| | Total dissolved solids | 40 CFR 136 Method 160.3 | |
| | Chemical oxygen demand | 40 CFR 136 Method 410.4 | |
| By-product emissions (air) | Constituent concentrations | EPA Method 320 (40 CFR 63 App. A) | Constituent speciation measurements necessary to determine any degradation by-products resulting from incomplete breakdown of constituents (e.g., dichloroethane to methylene chloride) |
| | | EPA Method 0030 (EPA's SW-846) | |
| | | Appropriate total organics (TO) method (e.g., EPA Method TO-15) | |
| | | Portable gas chromatography/mass spectrometry (GC/MS) | |

(continued)

Table 1. (continued)

| Factors to be Verified | Parameter to be Measured | Measurement Method | Comments |
|--|--|---|---|
| Associated Resource Usage (continued) | | | |
| Energy consumption of technology | Energy usage (may require measurement at multiple locations) | ASTM E929-83 (1983) kilowatt-hour meter | ECM 1200 or 400 from Brultech Research or equivalent |
| Consumable process chemicals / additives | Feed rates and times | Varies with technique of feeding | Identify and specify measurement in T/QAP |
| Makeup water usage <i>[Usage = rate x time]</i> | Water flow rate to APCT, volume per time, and usage time | Water flow meter | Orifice plate, magnetic flow meter, manual volumetric measurement |
| Pressure drop across APCT | Pressure difference | Differential pressure gauge or two pressure gauges | Δp @ start and end of test |
| Test Conditions Documentation | | | |
| Bioreactor volume if needed (may be proprietary) | Volume in which VOC conversion reaction occurs | Calculate from dimensions given in blueprints or on-site measurements | Determine on-site: active (media) volume to be defined in T/QAP |
| Flow rate to biofilter/ bioreactor | Flue gas volumetric flow rate to reactor | Installed gas flow meter, EPA Methods 1- 4 or 19 (40 CFR 60 App. A) | Usually an important test condition |
| Percent of operating unit's rated capacity | Empty bed residence time (EBRT) or pollutant loading | Calculated value using media volume, gas flow, and VOC concentration | Compare to manufacturer's capacity rating or experience without control technology; EBRT is generally considered the primary design parameter for bioreactors |
| Unit exit temperature | Gas temperature | Thermocouple at outlet | Indicative of operation and adequate water flow |

(continued)

Table 1. (continued)

| Factors to be Verified | Parameter to be Measured | Measurement Method | Comments |
|--|---|---|--|
| Test Conditions Documentation | | | |
| Water or steam input | Water or steam input rate and usage time | Water or steam flow meter | Value may be taken from process control panel |
| Ambient conditions | Ambient air temperature | ASTM E337-84: dry bulb | Measure all ambient conditions concurrently Use of data from nearest airport meteorological station, if available |
| | Ambient air pressure | ASTM D3631-95: aneroid barometer | |
| | Ambient air humidity | ASTM E337-84: psychrometer | |
| Microbiological Examination | | | |
| Microbes in gas stream | Number and species | Sampling: AGI 30 (liquid impingement sampler) | RTI will provide this specialized air sampler if unavailable to test organization |
| Microbes in liquid stream | Number and species | Sampling: Follow good scientific practices for collection of a single grab sample of each effluent stream | Sampling should be conducted when the bio-system is running at (or near) steady-state mode; appropriate care should be taken by the individual collecting it so as not to contaminate the sample |
| Sample transfer | | Follow RTI "SOP" for "shipping and handling" of samples | Samples sent to (RTI) lab for analysis; RTI standard operating procedures to be implemented |
| Microbial analysis of collected samples (gas and liquid) | Bacteria and fungi, both grown at 25 °C and 37 °C | Analysis: American Public Health Association Method 9215 C, Heterotrophic Plate Count – Spread Plate Method Triplicate samples will be analyzed. | Analysis should be conducted "in the spirit of" the reference method and follow the general procedures provided |

The following sections discuss the techniques for providing on-site quantitative measurement of VOC. In each case, successful measurement of target VOCs is largely contingent upon correct application of the proper method for the particular gas matrix involved. An overview of some of the details involved in selecting and applying each of the methods is described in the following sections. EPA methods for measuring gaseous organic emissions that are listed include:

- Method 18, Measurement of Gaseous Organic Compound Emissions by Gas Chromatography <http://www.epa.gov/ttn/emc/promgate/m-18.pdf>
- Method 25A, Determination of Total Gaseous Organic Concentration Using a Flame Ionization Analyzer <http://www.epa.gov/ttn/emc/promgate/m-25a.pdf>
- Method 320, Measurement of Vapor Phase Organic and Inorganic Emissions by Extractive Fourier Transform Infrared (FTIR) Spectroscopy <http://www.epa.gov/ttn/emc/promgate/m-320.pdf>
- SW 846, Method 0030, Volatile Organic Sampling Train (VOST) <http://www.epa.gov/epaoswer/hazwaste/test/pdfs/0030.pdf>
- Method TO-15, Determination of Volatile Organic Compounds (VOCs) in Air Collected in Specially-prepared Canisters and Analyzed by Gas Chromatography Mass Spectrometry (GC/MS) <http://www.epa.gov/ttn/amtic/files/ambient/airtox/to-15r.pdf>
(One of the other TO methods may be required for some analytes.)
- Methods in EPA's Compendium of Methods for the Determination of Toxic Organic Compounds in Ambient Air - Second Edition <http://www.epa.gov/ttn/amtic/files/ambient/airtox/tocomp99.pdf>
- Portable GC/MS

EPA methods for measuring organics in aqueous streams include:

- SW 846, Method 9060, Total Organic Carbon <http://www.epa.gov/epaoswer/hazwaste/test/pdfs/9060.pdf>
- Method 311, Analysis of Hazardous Air Pollutant Compounds in Paints and Coatings by Direct Injection into a Gas Chromatograph <http://www.epa.gov/ttn/emc/promgate/m-311.pdf>

- Methods in Appendix A of 40 CFR 136, Guidelines Establishing Test Procedures for the Analysis of Pollutants
http://www.access.gpo.gov/nara/cfr/waisidx_01/40cfr136_01.html

3.3.1 Emission Measurements for Total Volatile Organic Compounds (VOCs)

Two primary techniques available for providing measurement of total VOCs include total hydrocarbon analysis and gas chromatography. These are discussed below.

Total Hydrocarbon Analyzer – EPA Method 25A. The Total Hydrocarbon (THC) Analyzer is used to determine the total gaseous concentration of VOCs detectable by a flame ionization detector (FID). The method is best used for gas streams containing primarily alkanes, alkenes, and/or arenes (aromatic hydrocarbons), although any combustible carbon-containing compound will give a response on the instrument. The analyzer is calibrated using a known concentration gas standard, usually propane or other alkane. The gas sample is extracted from the source, typically through a heated line and particulate filter.

Advantages of the THC analyzer are the relative simplicity of operation (versus on-line gas chromatography [GC], Fourier transform infrared [FTIR], or gas chromatography/mass spectrometry [GC/MS], for example), ruggedness of the instrument, and ability of the FID to respond to a wide range of compounds.

The FID itself is perhaps the greatest strength and also the biggest disadvantage of the THC analyzer. This type of detector uses a small flow of hydrogen to maintain a flame that the sample gases pass across. Combustible gases that cross the flame are ignited, creating a response measured by the flame ionization detector. The flame ionization potential is not the same for all compounds, however, and the instrument response will vary accordingly. Aliphatic hydrocarbons provide the best performance, and have a response factor of approximately 0.95 to 1.05 per carbon atom (i.e., methane is approximately 1, ethane is approximately 2, propane is approximately 3, etc.). For compounds with more complex structures, such as alcohols, carbonyls, chlorinated species, and the like, response factors vary even further from the ideal of 1.0, and typically lower the response to the range of 0.5 to 0.8 per carbon atom. All combustible compounds in the gas stream pass across the flame simultaneously to produce a single summed response.

The detection limit of the FID is typically down to 1 ppm. The FID can also be mated with a separation system such as a GC to provide response to individual species. This technique is quite different from a simple FID, however, and is more thoroughly discussed below in the section on Method 18.

Gas Chromatograph – EPA Method 18. Method 18 can provide total (speciated) VOC concentration when there are only a limited number of known VOC components. VOCs present in the sample are separated by GC and are individually quantified by FID, photoionization detectors (PID), or electron capture detectors (ECD). Selection of the mode for quantifying VOCs is based on the type of components in the gas stream. The FID is the most commonly used and is best for most carbon-containing compounds. The PID responds well to aromatic compounds and unsaturated chlorinated hydrocarbons, and is often used in tracer gas studies because it responds well to sulfur hexafluoride. PIDs are sensitive to moisture and can give erroneously high readings if significant amounts of water vapor are present in the sample. Also, the response of PIDs, and other detectors, may drift requiring frequent calibration. If the target list contains chlorinated compounds at low levels, an ECD may be a better choice.

Compounds with low vapor pressures (less than 10 mm Hg at ambient temperature) and/or high molecular weight (in the polymeric range, approximately 500 atomic mass units [amu] or higher) are the most difficult to analyze by Method 18. The method does not discuss concentrating techniques to measure VOCs below approximately 1 ppm, although it is possible to establish a practical quantitation limit (PQL) as low as 0.1 ppm for some compounds under ideal conditions. Concentrating methods, such as sorbent traps or cryogenic traps, can also be used to lower the detection limits for most volatile compounds.

To verify the presence of specific compounds, the retention time of each peak on the chromatogram is compared with those of standards injected under identical conditions. Typically, a VOC screening mixture is prepared containing target compounds expected to be found at a source. Significant peaks that do not correlate with any of the target compounds may be classified as tentatively identified compounds and additional standards can be run to confirm the compounds and quantify them. If a tentative identification cannot be made, a rough concentration can be determined by using an assumed response factor.

A GC may be operated either on-site (portable) or with collection of grab samples analyzed at an off-site laboratory to quantitatively measure gaseous emissions. EPA Method 18 allows both on-site and off-site operation of the gas chromatography. Samples are collected using a sample pump and flexible containers such as Tedlar bags.

3.3.2 Emission Measurements for Total Non-Methane VOCs

Combined EPA Method 25A and EPA Method 18 for Methane. The two techniques discussed above may also be combined to provide a measurement of non-methane THC. Method 18 can be conducted by taking bag samples that are subsequently analyzed for methane, and the methane results subtracted from the Method 25A THC results. Method 18 is appropriate for applications for total VOCs where there are only a few known VOC components in the gas stream.

Gas Chromatograph – EPA Method 18. Method 18 as discussed above can also be conducted to provide a measurement of methane in addition to the known VOC components in the gas stream. The methane results would be subtracted to estimate the non-methane VOC results.

3.3.3 Emission Measurements for Speciated VOCs

Gas Chromatograph – EPA Method 18. Method 18 provides speciated measurement of VOC compounds. The discussion above in Section 3.3.1 explains use of the method in identifying specific compounds.

Extractive FTIR – EPA Method 320. Because most VOCs have distinct infrared spectra, extractive FTIR spectroscopy can be used to monitor for compounds under a range of potentially useful conditions. The technique works best when one reasonably expects that all of the target species are (a) visible to infrared (IR) spectroscopy; (b) present at detectable concentrations; and (c) have minimal interference from ubiquitous contaminants such as water (H₂O) and carbon dioxide (CO₂). In general, the technique has a practical limit of characterizing gas mixtures with the presence of no more than perhaps 10 or so individual species.

FTIR spectroscopy provides direct identification of compounds present in the flue gas by recording their infrared absorbance across a defined spectral region. Individual compounds may be identified and quantified by comparison to spectra from a reference library in either real-time or after-the-fact. Accurate assumptions about the presence or absence of target compounds and interferences greatly enhance the ability of this method to provide real-time analysis. Reference libraries are available through EPA or commercial vendors, and reference spectra for specific gas mixtures or unusual components can also be custom-built by contractor laboratories.

Heated FTIR cells can be configured to allow multiple passes of the IR beam through the sample gas. The effective path length (normally about 20 meters) can be adjusted, depending on the pollutant concentrations. Increasing the number of passes through the cell reduces the detection limit for compounds by increasing the spectral absorbance but can also increase interferences or saturate the detector. FTIR cells may be coated with polytetrafluoroethylene or constructed from other relatively inert materials to minimize potential wall reactions that can cause analyte losses. Mercury/cadmium/telluride detectors cooled by liquid nitrogen are used to detect the spectral absorbance.

EPA Method 320 specifies sampling procedures, and EPA's FTIR Protocol contains procedures for analyzing the spectra. Computer programs are typically employed that use automated routines to analyze the spectra and mathematical techniques to determine concentrations. Programs can usually be modified to also measure any pollutants observed and adjust for interferent concentrations. Quantitative results can be obtained in near real-time, and the spectra can also be examined in detail later.

Detection limits are compound- and matrix-dependent and typically range from about 0.2 ppm to about 5 ppm for most compounds in high-moisture sources. To achieve lower detection limits, FTIR spectroscopy can be combined with sample conditioning techniques (to remove interferents such as moisture or carbon dioxide), separation techniques (such as GC), or concentrating techniques (such as a sorbent bed).

Portable GC/MS. In recent years, portable GC/MS units have become commercially available and provide another useful tool for on-site emissions measurements. Portable GC/MS analyzers contain a small, lightweight GC coupled to a rugged mass spectrometer. They require low moisture (less than 8%) and temperature (less than 250 °F) in the sample and thus may require a condenser, water knockout, or other sample conditioning, depending on the process being sampled.

On-site GC/MS use should include pretest preparation for the anticipated target compounds and sample matrix. Flexible bags can be filled with spiked gas mixtures of VOCs at expected target levels to confirm the instrument's quantitation routine. Calibration gases should include some or all of the expected target compounds because only qualitative results will be obtained if actual response factors are not determined. Compounds detectable by this method include many organic volatile compounds with masses up to approximately 300 or 400 amu. Under good field conditions, the PQL for most compounds detectable by this technique is 50 to 100 parts per billion by volume (ppb). In a stack gas matrix, results can usually be obtained for compounds present at 300 ppb or higher.

Another alternative to the direct interface GC/MS is the use of a sorbent or analytical trap procedure. Sorbent tubes containing carbon fibers (e.g., Tenax) or carbon molecular sieves (e.g., Carboxen) are available for use with some of the commercially-available instruments. Appropriate use of a concentrating technique can reduce the PQL for many volatile compounds to a few parts per billion (ppb).

Methods in EPA's Compendium of Methods for the Determination of Toxic Organic Compounds in Ambient Air - Second Edition. One or more of methods in EPA's "Compendium of Methods for the Determination of Toxic Organic Compounds in Ambient Air - Second Edition" could also be used. The TO methods (and updates) can be downloaded from the EPA web site shown in Section 3.3.

3.3.4 Emission Measurements for VOC Removal Efficiency

Calculation of the VOC removal efficiency requires estimation of the mass rate in the inlet stream to the biofilter and the mass rate of VOC in the outlet streams from the biofilter (both gaseous and water streams). The same VOC measurement methods should be conducted on both the inlet and outlet gas streams; possible measurement methods are discussed in the preceding sections. For these gaseous streams, the volumetric flow rates are determined using EPA

Method 2. The mass emission rates are determined by multiplying the VOC concentration by the flow rate. A VOC's removal efficiency is determined by summing the total VOC input to the biofilter, subtracting the total sum of VOC output from the system (gas and water streams), and dividing by the total VOC input.

3.3.5 Emission Measurements for By-products

Extractive FTIR – EPA Method 320. Extractive FTIR can also be used to identify unknowns in certain matrices. In simplest terms, the technique for identifying unknowns involves spectrally subtracting the previously identified compounds, then using spectral libraries to identify the compound(s) remaining. The discussion in Section 3.3.3 explains the technique for measuring known VOCs.

As each of the target species is identified, they are quantified by scaling a reference spectrum to match the sample spectrum as closely as possible. Because this is all done on a computer, it is then possible to mathematically subtract the scaled reference spectrum, essentially removing it from the sample. Once all the identified targets have been removed, the remaining peaks are unknown and can only be identified through the somewhat tedious process of reviewing spectral reference libraries and literature sources. Experience of the analyst is extremely important for identifying classes of compounds, such as carbonyls or the presence of C-H bonds, for example. Other difficulties may arise when there are minor differences between the sample spectrum and the reference spectrum, creating artifacts when poor subtraction occurs.

Many instrument and software vendors have computerized spectral libraries available for purchase. Literature sources can include published papers, scientific journals, and other types of printed matter. Some difficulties arise when using certain reference materials due to differences in instrument resolution, sample conditions, and translation of the information to a computerized system.

Volatile Organic Sampling Train – Method 0030 and Laboratory Analysis by MS. The volatile organic sampling train (VOST) described in EPA test methods 0030 and 0031 can be used for collecting screening samples. The sampling system requires a metering pump and cooling water for the sorbent cartridges, and is therefore generally not as portable as Tedlar bag grab sampling.

The apparatus draws sample gas through a set of sorbent tubes that function as traps (two or three, depending on the method used), where the gases are collected and concentrated. The first tube is typically filled with a carbon fiber (e.g., Tenax), while the last trap typically contains a carbon fiber section and a backup section of activated carbon. Following collection, the tubes are shipped to the laboratory where they are desorbed and analyzed, usually by GC/MS. Condensate from the gas stream is also collected and can be analyzed for water-soluble constituents in the gas stream.

Sample collection time can range from a few minutes to several hours, depending on the concentrations of the target species. Sample handling is important for this method, and samples must be stored in a sealed, contaminant-free container and kept on ice. Analysis of the traps must be completed within 14 days of collection. Sorbent trap preparation prior to testing is also important, since they must be cleaned, purged with dry nitrogen, analyzed for cleanliness, stored in sealed containers, and shipped to the site without compromising sample integrity.

For screening unknown contaminants, the VOST method can be applied to many VOCs. With GC/MS analysis, the method should have PQLs as low as 15 ppb. Another advantage includes the method's widespread use and nearly universal acceptance by regulatory agencies. Many analytical laboratories have developed VOST-based methods that are not standard. The technique is generally good for a target list of commonly specified compounds (i.e., a "hit" list), but is somewhat poorer as a screening tool for complete unknowns. Another disadvantage is that each trap can only be analyzed once.

Portable GC/MS. Portable GC/MS may also be used to screen and identify unknown byproduct compounds. The discussion above in Section 3.3.3 explains use of the technique for known species. Additional work would be necessary to identify unknown components.

3.3.6 Effluent Measurements for VOC (Removal Efficiency)

If a speciation method is used to measure individual VOCs in liquid effluent streams, a speciation method should be used to measure the same individual VOCs in gaseous streams. In this approach, a separate removal efficiency could be determined for each individual VOC measured.

Total Organic Carbon – Method 9060. TOC analysis (Method 9060) will probably not be adequate/accurate for evaluation of VOCs in the liquid effluent streams from the biofilter system because of organic carbon contamination due to the presence of nutrients or microbe excretions in the effluent. A method that measures specific organic compounds (e.g., Method 311) may be needed to account for organics introduced to or exiting the system.

Analysis of Hazardous Air Pollutant Compounds in Paints and Coatings by Direct Injection into a Gas Chromatograph – Method 311. Method 311 was developed to measure individual organic compounds, with an emphasis on HAPs, present in or formed during the curing of coatings. Concentrations measured by Method 311 are usually relatively high ($\geq 0.01\%$ as compared to the usual parts-per-million or parts-per-billion for environmental samples).

Volatile Organic Compounds by GC-MS – Method 8260. The water methods in SW-846 (particularly Method 8260) may be more appropriate for speciation of VOCs in liquid effluent streams from biofilters.

Methods in Appendix A of 40 CFR 136 Guidelines Establishing Test Procedures for the Analysis of Pollutants. These may be used to measure many VOCs in aqueous phases. Tables IC, ID, and IE in 40 CFR 136.3 list compounds for which the various water methods in the Appendix have been validated.

3.3.7 Emission and Effluent Measurements for Microorganisms

The population of microbes used in bioreactors varies from application to application. Bacteria and fungi are clearly the two dominant microorganism groups in bioreactor systems. Naturally occurring microbes are usually suitable and most desirable for treating most gas phase contaminants. However, some of the more unusual anthropogenic chemicals tend to require more specialized microorganisms. Sometimes these specialized organisms are simply taken from sewage sludge and acclimated to the specific contaminants that are present; in a few cases, specially grown pure, mixed, or genetically engineered cultures may be preferred. The presence of microorganisms in bioreactor system media has raised concerns over their potential release into the treated off-gas or liquid effluents exiting the system and a resultant potential exposure to pathogens. To address this concern, this GVP includes a requirement that each verification test for bioreactor systems include microbial screening tests.

To provide meaningful data at a reasonable cost, GVP testing will include one-time screening tests (conducted in triplicate) for indicator organisms present in any exhaust gas and effluent streams exiting the bioreaction system. Because of the large number of possible microbes that could be present, the GVP will limit testing to enumerate and identify organisms that are able to grow at either one of two critical temperatures (i.e., 25 °C and 37 °C) on general purpose growth media. Many organisms require specialized growth media. It is not practical to utilize many different media; therefore, one general purpose medium for bacteria and another for fungi will be used. The use of the general purpose medium will provide an indication of potential for exposure to pathogenic organisms. The two temperatures were selected to characterize two distinct conditions. The 25 °C case was chosen to identify those microbes that grow at ambient temperatures; the 37 °C case was chosen to determine the presence or absence of the general class of microbes that grow at body temperature (i.e., an indicator for organisms that pose a potential health threat or risk to humans). Screening for microbes at these two critical temperatures on general purpose media, although in no way considered a comprehensive analysis, concentrates efforts on testing for those organisms that are potentially harmful to human health or the environment.

Method 9215 C, Heterotrophic Plate Count – Spread Plate Method. This American Public Health Association (APHA) method provides standard procedures for estimating the number of live microorganisms in a sample. The colony morphology easily can be discerned and compared to published descriptions.

3.4 Sampling

Sampling related to the GVP testing can be accomplished in several ways: (1) continuous monitoring, (2) grab samples taken at specified time intervals, or (3) integrated samples collected at a known sampling rate over a known period of time. The last two types of samples (grab and integrated) must be analyzed in a second step that may require equipment found only in a laboratory. Continuous monitoring of the system by Method 25A during sampling would provide reassurance that the appropriate number of samples were being collected at appropriate times for the verification test. Method 25A monitors on the inlet and outlet air streams could be used to provide real-time data and to characterize the stability of the system. Method 25A measurements could also be used to determine if the system has reached a steady-state, or if the system is operating in a cyclic or episodic fashion. The sampling schedule must include enough samples collected over a sufficient period of time to fully evaluate the system regardless of its mode of operation (steady-state, cyclic, or episodic). Ideally, sufficient analytical data will be collected to allow integration of VOC measurements over the entire testing period, which may include multiple cycles or episodic events (if the system is operating in one of those two modes).

4.0 REQUIREMENTS FOR TEST/QA PLAN

4.1 Quality Management

All test organizations participating in the ETV Program must meet the QA/QC requirements defined below and have an adequate quality system to manage the quality of work performed. Documentation and records management must be performed according to the *ETV Program Quality Management Plan* (ETV QMP, EPA, 2003) or its successor document. Test organizations must also perform assessments and allow audits by the APCTVC (headed by the APCT QA Officer) and EPA corresponding to those in Section 8.

All participating test organizations must have an ISO 9000-accredited (ISO, 1994) or ANSI E4-compliant (ANSI, 1994) quality system and an EPA- or APCTVC-approved QMP.

4.2 Quality Assurance (QA)

All ETV testing will be done following an approved T/QAP that meets *EPA Requirements for Quality Assurance Project Plans* (EPA, 2001a) and Part B, Section 2.2.2 of EPA's ETV QMP (EPA, 2003) or its successor document. These documents establish the requirements for T/QAP and the common guidance document, *Guidance for Quality Assurance Project Plans* (EPA, 1998), provides guidance on how to meet these requirements. The APCT Quality Management Plan (RTI, 1998) implements this guidance for the APCTVC.

As above, detailed reference to SOPs, federal test methods, or other available documents is encouraged. Any needed SOPs will be developed in accordance with *Guidance for Preparing Standard Operating Procedures (SOPs)* (EPA, 2001b.)

The test organization must prepare a T/QAP and submit it for approval by the APCTVC. The T/QAP must be approved before the test organization can begin ETV testing.

A T/QAP contains the elements listed below, the contents of which may stand alone or include references to the EPA test methods or other widely distributed and publicly available sources. If specific elements are not included, an explanation for not including them must be provided.

1. Title and approval sheet;
2. Table of contents, distribution list;
3. Test description and test objectives;
4. Identification of the critical measurements, data quality objectives (DQOs) and indicators, test schedule, and milestones;
5. Organization of test team and responsibilities of members of that team;
6. Documentation and records;
7. Test design (e.g., test methods, sampling times, number of runs);
8. Sampling procedures;
9. Sample handling and custody;
10. Analytical procedures;
11. Test-specific procedures for assessing data quality indicators;
12. Calibrations and frequency;
13. Data acquisition and data management procedures;
14. Internal systems and performance audits;
15. Corrective action procedures;
16. Assessment reports to EPA;
17. Data reduction, data review, data validation, and data reporting procedures;
18. Reporting of data quality indicators for critical measurements;
19. Limitations of the data; and
20. Any deviations from methods cited in this generic verification protocol.

The APCTVC will provide a T/QAP template that illustrates its expectations.

4.3 Additional Requirements to be Included in the Test/QA Plan

The T/QAP must include or reference a diagram and description of the extractive gaseous measurement system to be used for the testing and a list of the reference analyzers and measurement ranges to be used for quantifying the concentrations of all gaseous compounds to be measured, including both primary and ancillary pollutants.

The T/QAP must include or reference a schematic drawing showing all sample and test locations, including the inlet and outlet to the technology sampling locations. The location of flow disturbances and the upstream and downstream distances from the sampling ports to those flow disturbances must be noted. The number of traverse points that will be sampled must be provided.

The T/QAP must include or reference the appropriately detailed descriptions of all measuring devices and reference methods that will be used during the test.

The T/QAP must explain or reference the specific techniques to be used for monitoring process conditions appropriately for the source being tested. It must also note the techniques that will be used to estimate any other operational parameters.

5.0 REPORTING AND DOCUMENTATION REQUIREMENTS

This section describes the procedures for reporting data in the ETV report and the verification statement. The specifics of what data must be included and the format in which the data must be included are addressed in this section (e.g., QA/QC summary forms, raw data collected, photographs/slides/video tapes). The ETV report for each technology will include (at the option of the technology's vendor) the verification statement at the front of the report. The verification statement is a short summary of the ETV results. An example draft is attached as Appendix A. The ETV VR, including the VS, will be written by the APCTVC based on the test report submitted by the test organization. The VR and VS will be reviewed by the APCTVC and the technology applicant before being submitted to EPA for review and approval as specified in the ETV QMP.

5.1 Data Reduction

Data from measurements made as part of the ETV verification test will be reported in the following units:

- The units stipulated in the method followed,
- SI units, or
- English units.

The VOC emission rate from the verification test will be reported in:

- Parts per million by volume (ppmv),
- ppmv corrected to a standard percent oxygen (or humidity), and
- Pounds per hour (lb/hr) as VOC, THC, speciated compound (dependent on test method used).

The percent (%) confidence limits on the VOC emission rate will be presented.

A unit conversion table from English (British Engineering Units) to SI units will be provided. The VOC removal efficiency will be determined from the inlet VOC mass rate and the outlet VOC mass emission rate according to the following equation:

$$\text{Removal efficiency, \%} = 100(\text{inlet VOC, lb/hr} - \text{outlet VOC, lb/hr}) / \text{inlet VOC, lb/hr.}$$

The percent (%) confidence limits on the VOC removal efficiency will be presented.

The inlet VOC mass rate will take into account the VOCs entering the system in the gas/air stream and any VOCs entering the system in any of the liquid streams that are fed to the system, such as process water and additives. Outlet VOC mass emission rate will take into account any VOC loss or reduction attributable to outlet or effluent streams from the humidification stage and any effluent from the bioreaction vessel, as well as the exhaust gas from the control device.

5.2 Reports

The test organization will prepare the ETV test report that describes and documents the ETV testing that was conducted and the results of that testing. The test report includes the following topics:

- Draft VS,
- Introduction,
- Description and identification of product tested,
- Procedures and methods used in testing,
- Statement of operating range over which the test was conducted,
- Summary and discussion of results as required to:
 - Support the VS,
 - Explain and document necessary deviations from test plan, and
 - Discuss QA issues,
- Conclusions and recommendations,
- References, and
- Appendices:
 - QA/QC activities and results,
 - Raw test data, and
 - Equipment calibration results.

The verification statement will include the following:

- Technology vendor's name and technology's descriptive information,
- Summary of ETV test program,

- Results of the ETV test,
- Any limitations of the ETV results, and
- Brief QA statement.

Review and approval of the draft ETV report and statement are as described in Section 3.0. A draft verification statement is attached to this protocol as Appendix A.

6.0 DISSEMINATION OF ETV REPORTS AND VERIFICATION STATEMENTS

After a control technology has been tested and the draft VR and VS received from the test organization, the APCTVC will send a draft of both to the applicant for review prior to submission to EPA-ORD and release of the approved report to the public. This gives the vendor opportunity to review the results, test methodology, and report terminology while the drafts remain working documents and are not publicly accessible. The vendor may submit comments and revisions on the draft statement and report to the APCTVC. The APCTVC will consider these comments and may suggest revisions of its own.

After incorporating appropriate revisions, the draft final VR and VS will be submitted to EPA-ORD for review and approval. Following approval, three copies of the ETV report will be prepared with one copy going to the vendor, one to EPA, and one to the APCTVC. Distribution of additional copies of the final ETV report, if desired, is at the vendor's discretion and responsibility. However, approved VSs and VRs will be posted on the ETV web site for public access without restriction. The VR report appendices will not be posted on the web site, but will be publicly available from the APCTVC. A signed original VS and VR will be filed and retained by the APCTVC, and signed originals will also be provided to the vendor and to EPA.

7.0 LIMITATIONS ON TESTING AND REPORTING

To avoid having multiple ETV reports for the same product and to maintain the ETV testing as a cooperative effort with the vendor, the following restrictions apply to ETV testing under this protocol:

- Applicants may submit only products they manufacture or whose distribution they control. Applicants may not submit for ETV testing pollution control devices whose use is not in their control except with the agreement of the manufacturer or vendor.
- For a given product (e.g., brand and model), APCTVC's policy is that only one ETV report and statement will be issued for any single application.
- Air pollution control technology frequently performs differently in different applications. Applicants may request additional tests of essentially identical

technology if it is being applied to pollution sources that are clearly different from those for which ETV verifications have been obtained.

8.0 ASSESSMENT AND RESPONSE

Each independent test laboratory must conduct internal assessments of its quality and technical systems and must allow external assessments of these systems by the APCTVC QA personnel and by EPA QA personnel. After an assessment, the test laboratory will be responsible for developing and implementing corrective actions in response to the assessment's findings.

As appropriate, the APCTVC and/or EPA will conduct assessments to determine the test organization's compliance with its T/QAP. The requirement to conduct assessments is specified in EPA's *ETV Program Quality Management Plan* (EPA, 2002a), and in the APCTVC's QMP (RTI, 2003). EPA will assess the APCTVC's compliance with their T/QAPs. The APCTVC will assess the compliance of other organizations with their T/QAPs. The assessments will be conducted according to *Guidance on Technical Audits and Related Assessments for Environmental Data Operations* (EPA, 2000) and *Guidance on Assessing Quality Systems* (EPA, 2001.)

8.1 Assessment Types

Quality system assessment – Qualitative assessment of a particular quality system to establish whether the prevailing quality management structure, policies, practices, and procedures meet EPA requirements and are adequate for ensuring the type and quality of measurements needed.

Technical systems audit – Qualitative on-site audit of the physical setup of the test. The auditors determine the compliance of testing personnel with the T/QAP.

Performance evaluation audit – Quantitative audit in which measurement data are independently obtained and compared with routinely obtained data to evaluate the accuracy (bias and precision) of a measurement system.

Audit of data quality – Qualitative and quantitative audit in which data and data handling are reviewed and data quality and data usability are assessed.

Surveillance audit – Observation of ongoing work to document conformance with specified requirements and/or procedures, such as those given in a T/QAP or SOP.

8.2 Assessment Frequency

Activities performed during ETV performance operations that affect the quality of the data shall be assessed regularly and the findings reported to management to ensure that the requirements stated in the generic verification protocols and the T/QAPs are being implemented as prescribed.

The types and minimum frequency of assessments for the ETV Program are listed in Part A Section 9.0 of EPA's *ETV Quality Management Plan* (EPA, 2002a). Tests conducted by the APCTVC will have at a minimum the following types and numbers of assessments:

1. Technical systems audits and surveillance audits: Self-assessments by test organization as provided for in the T/QAPs and at least one independent assessment of the test organization.
2. Performance evaluation audits: Self-assessments by test organization as provided for in the T/QAPs and at least one independent assessment of the test organization.
3. Audits of data quality: Self-assessments by the test organization of at least 10% of all the ETV data with detailed reports of the audit results to be included in the data packages sent to the APCTVC for review.
4. Assessments of quality systems: Self-assessments by the test organization as provided for in the T/QAPs and at least one independent assessment of the test organization.

The independent assessments of tests conducted by RTI will be performed by EPA. The independent assessments of other organizations will be by the APCTVC.

8.3 Response to Assessment

When needed, appropriate corrective actions shall be taken and their adequacy verified and documented in response to the findings of the assessments. Data found to have been taken from non-conforming technology shall be evaluated to determine its impact on the quality of the required data. The impact and the action taken shall be documented. Assessments are conducted according to procedures contained in the APCTVC QMP. Findings are provided in audit reports. Responses by the test organizations to adverse findings are required within 10 working days of receiving the audit report. Follow up by the auditors and documentation of responses are required.

9.0 SAFETY MEASURES

9.1 Safety Responsibilities

The test laboratory's project leader is responsible for ensuring compliance with all applicable occupational health and safety requirements. Each individual staff member is expected to follow the requirements and identify personnel who deviate from them and report such action to their supervisor.

9.2 Safety Program

The test company must maintain a comprehensive safety program and ensure that all test personnel are familiar with and follow it. In addition, field personnel are expected to familiarize themselves with the site safety practices. If required, field personnel will attend a safety orientation with the plant safety officer. Before or on the first day onsite, the test company's field team leader will fill out an Emergency Response Procedure form, discuss it with test team members, and post it at a place or places accessible to all test team work stations. The form will include as a minimum:

- Procedures for obtaining emergency medical assistance,
- Procedures for reporting fires and security threats,
- Location of first aid station(s) and evacuation routes, and
- Location and directions to local hospital(s).

9.3 Safety Requirements

All test personnel will adhere to the following general safety requirements:

- Confine themselves to authorized areas only,
- Wear protective glasses or goggles and headgear at all times where designated,
- Wear steel-toed boots or shoes where designated,
- Wear hearing protection at all locations where designated, and
- Wear other personal protective equipment as required or specified in the T/QAP.

10.0 REFERENCES

American Public Health Association. Standard methods for the Examination of Water and Wastewater, 19th Edition. Method 9215C. *Heterotrophic Plate Count Spread Plate Method*. Washington, DC. 1995.

ASQC. *AMERICAN NATIONAL STANDARD Specifications and Guidelines for Quality Systems for Environmental Data Collection and Environmental Technology Programs*. ANSI/ASQC E4-1994. American Society for Quality Control. Milwaukee, WI. 1994.

ASTM. Standard D3631-99. *Standard Test Methods for Measuring Surface Atmospheric Pressure*. ASTM, International. West Conshohocken, PA. 1999.

ASTM. Standard E70-97. *Standard Test method for pH of Aqueous Solutions With the Glass Electrode*. ASTM, International. West Conshohocken, PA. 1997.

ASTM. Standard E337-84. *Standard test method for Measuring Humidity with a Psychrometer (the Measurement of Wet-and Dry-Bulb Temperatures)*. ASTM, International. West Conshohocken, PA. 1984.

ASTM. Standard E929-83. *Standard Test Method for Measuring Electrical Energy Requirements of Processing Equipment*. ASTM, International. West Conshohocken, PA. 1983.

Center for Waste Reduction Technologies. *Biofiltration: Project Report & Scale-Up and Design Guide*. American Institute of Chemical Engineers. New York, NY. 1999.

Deviny, J.S., et al. *Biofiltration for Air Pollution Control*. Lewis Publishers. Washington, D.C. 1999.

EPA. *EPA Guidance for Quality Assurance Project Plans. EPA QA/G-5*. EPA/600/R-98/018. <http://www.epa.gov/quality1/qs-docs/g5-final.pdf>, Office of Research and Development, U. S. Environmental Protection Agency. Washington, DC. February 1998.

EPA. *EPA Requirements for Quality Assurance Project Plans. EPA QA/R-5*, EPA/240/B-01/003. <http://www.epa.gov/quality/qs-docs/r5-final.pdf>, Office of Environmental Information, U. S. Environmental Protection Agency. Washington, DC. March 2001.

EPA. *ETV Program Quality Management Plan*. EPA 600/R-03/021. <http://www.epa.gov/etv/qmp.htm>, National Risk Management Research Laboratory–National Exposure Research Laboratory, Office of Research and Development, U.S. Environmental Protection Agency. Cincinnati, OH. December 2002.

EPA. *Guidance for the Preparing Standard Operating Procedures (SOPs)*. EPA QA/G-6. EPA 240/B-01/004. <http://www.epa.gov/quality/qs-docs/g6-final.pdf>, Office of Environmental Information, U.S. Environmental Protection Agency. Washington DC. March 2001.

EPA. *Guidance on Assessing Quality Systems (Quality Staff Draft)*. EPA QA/G-3. Office of Environmental Information, U.S. Environmental Protection Agency. Washington, DC. August 2001.

EPA. *Guidance on Technical Audits and Related Assessments for Environmental Data Operations*, EPA QA/G-7. EPA/600/R-99/080. <http://www.epa.gov/quality/qs-docs/g7-final.pdf>, Office of Environmental Information, U.S. Environmental Protection Agency. Washington, DC. January 2000.

ICAC. *White Paper: Biofiltration for Air Pollution Control*. Prepared by Biofiltration White Paper Committee, Institute of Clean Air Companies, Inc. Washington, D.C. September 1993.

ISO. *ISO 9001-1994, Quality Systems Model for Quality Assurance in Design, Development, Production, Installation, and Servicing*. International Organization for Standardization. Geneva, Switzerland. In USA, American National Standards Institute. New York, NY. 1994.

RTI. *Verification Testing of Air Pollution Control Technology - Quality Management Plan*. Air Pollution Control Technology Program. J. R. Farmer, Program Director, Research Triangle Institute. Research Triangle Park, NC. 1998.

U.S. Government. Protection of Environment. Title 40, Part 86, Code of Federal Regulations, as of July 1, 1999. Federal Register. Washington, DC. 1999.

U.S. Government. Protection of Environment. Title 40, Part 89, Code of Federal Regulations, as of July 1, 1999. Federal Register. Washington, DC. 1999.

U.S. Government. Protection of Environment. Title 40, Part 60, Appendix A, Code of Federal Regulations, as of July 1, 2000. EPA Method 1. *Sample and velocity traverses for stationary sources*. Federal Register. Washington, DC. 2000.

U.S. Government. Protection of Environment. Title 40, Part 60, Appendix A, Code of Federal Regulations, as of July 1, 2000. EPA Method 1A. *Sample and velocity traverses for stationary sources with small stacks or ducts*. Federal Register. Washington, DC. 2000.

U.S. Government. Protection of Environment. Title 40, Part 60, Appendix A, Code of Federal Regulations, as of July 1, 2000. EPA Method 2. *Determination of stack gas velocity and volumetric flow rate (Type S pitot tube)*. Federal Register. Washington, DC. 2000.

U.S. Government. Protection of Environment. Title 40, Part 60, Appendix A, Code of Federal Regulations, as of July 1, 2000. EPA Method 2A. *Direct measurement of gas volume through pipes and small ducts*. Federal Register. Washington, DC. 2000.

U.S. Government. Protection of Environment. Title 40, Part 60, Appendix A, Code of Federal Regulations, as of July 1, 2000. EPA Method 2C. *Determination of gas velocity and volumetric flow rate in small stacks or ducts (standard pitot tube)*. Federal Register. Washington, DC. 2000.

U.S. Government. Protection of Environment. Title 40, Part 60, Appendix A, Code of Federal Regulations, as of July 1, 2000. EPA Method 2D. *Measurement of gas volume flow rates in small pipes and ducts*. Federal Register. Washington, DC. 2000.

U.S. Government. Protection of Environment. Title 40, Part 60, Appendix A, Code of Federal Regulations, as of July 1, 2000. EPA Method 3. *Gas analysis for the determination of dry molecular weight*. Federal Register. Washington, DC. 2000.

U.S. Government. Protection of Environment. Title 40, Part 60, Appendix A, Code of Federal Regulations, as of July 1, 2000. EPA Method 3A. *Determination of Oxygen and Carbon Dioxide Concentrations in Emissions From Stationary Sources (Instrumental Analyzer Procedure)*. Federal Register. Washington, DC. 2000.

U.S. Government. Protection of Environment. Title 40, Part 60, Appendix A, Code of Federal Regulations, as of July 1, 2000. EPA Method 3C. *Determination of carbon dioxide, methane, nitrogen, and oxygen from stationary sources*. Federal Register. Washington, DC. 2000.

U.S. Government. Protection of Environment. Title 40, Part 60, Appendix A, Code of Federal Regulations, as of July 1, 2000. EPA Method 4. *Determination of moisture content in stack gases*. Federal Register. Washington, DC. 2000.

U.S. Government. Protection of Environment. Title 40, Part 60, Appendix A, Code of Federal Regulations, as of July 1, 2000. EPA Method 18. *Measurement of gaseous organic compound emissions by gas chromatography*. Federal Register. Washington, DC. 2000.

U.S. Government. Protection of Environment. Title 40, Part 60, Appendix A, Code of Federal Regulations, as of July 1, 2000. EPA Method 19. *Determination of sulfur dioxide removal efficiency and particulate sulfur dioxide and nitrogen oxides emission rates*. Federal Register. Washington, DC. 2000.

U.S. Government. Protection of Environment. Title 40, Part 60, Appendix A, Code of Federal Regulations, as of July 1, 2000. EPA Method 25A. *Determination of total gaseous organic concentration using a flame ionization analyzer*. Federal Register. Washington, DC. 2000.

U.S. Government. Protection of Environment. Title 40, Part 63, Appendix A, Code of Federal Regulations, as of July 1, 2000. EPA Method 320. *Measurement of vapor phase organic and inorganic emissions by extractive Fourier Transform Infrared (FTIR) spectroscopy*. Federal Register. Washington, DC. 2000.

U.S. Government. Protection of Environment. Title 40, Part 136, Appendix A, Code of Federal Regulations, as of July 1, 2000. EPA Method 160.3. *Residue–Total, mg/L: Gravimetric, 103-105 deg*. Federal Register. Washington, DC. 2000.

U.S. Government. Protection of Environment. Title 40, Part 136, Appendix A, Code of Federal Regulations, as of July 1, 2000. EPA Method 410.4. *Chemical oxygen demand, Spectrophotometric, manual*. Federal Register. Washington, DC. 2000.

U.S. Government. Test Methods for Evaluating Solid Waste, Physical/Chemical Methods. SW-846. Method 0030. *Volatile Organic Sampling Train*. Office of Solid Waste. Washington, DC.

U.S. Government. Test Methods for Evaluating Solid Waste, Physical/Chemical Methods. SW-846. Method 8260B. *Volatile Organic Compounds by Gas Chromatography Mass Spectrometry (GC/MS)*. Office of Solid Waste. Washington, DC.

U.S. Government. Test Methods for Evaluating Solid Waste, Physical/Chemical Methods. SW-846. Method 9060. *Total Organic Carbon*. Office of Solid Waste. Washington, DC.

U.S. Government. EPA Method TO-15. *The Determination of Volatile Organic Compounds (VOCs) in Air Collected in SUMMATM Canisters and Analyzed by Gas Chromatography/Mass Spectrometry (GC/MS)*. National Exposure Research Laboratory. Research Triangle Park, NC.

APPENDIX A: EXAMPLE VERIFICATION STATEMENT

Appendix A is an example verification statement written for a bioreaction system.

This generic verification statement is intended only to show the form of a verification statement. It will require modification for each technology verified, depending on the details of that technology's design, construction, and operation. The T/QAP written for each test will include a draft verification statement customized for the technology actually being tested. The text of that specific verification statement will address the significant parameters that apply to the technology tested.

THE ENVIRONMENTAL TECHNOLOGY VERIFICATION
PROGRAM



ETV Joint Verification Statement

| | | | |
|-------------------------|--|---------------|-----------------------|
| TECHNOLOGY TYPE: | BIOREACTION AIR POLLUTION CONTROL TECHNOLOGY | | |
| APPLICATION: | CONTROL OF VOC EMISSIONS USING BIOREACTION TECHNOLOGY | | |
| TECHNOLOGY NAME: | TECHNOLOGY NAME | | |
| COMPANY: | COMPANY NAME | | |
| ADDRESS: | ADDRESS | PHONE: | (000) 000-0000 |
| | CITY, STATE ZIP | FAX: | (000) 000-0000 |
| WEB SITE: | http://www.company.com | | |
| E-MAIL: | rlong@aafintl.com | | |

The U.S. Environmental Protection Agency (EPA) has created the Environmental Technology Verification (ETV) Program to facilitate the deployment of innovative or improved environmental technologies through performance verification and dissemination of information. The goal of the ETV Program is to further environmental protection by accelerating the acceptance and use of improved and cost-effective technologies. ETV seeks to achieve this goal by providing high quality, peer-reviewed data on technology performance to those involved in the design, distribution, financing, permitting, purchase, and use of environmental technologies.

ETV works in partnership with recognized standards and testing organizations; stakeholder groups which consist of buyers, vendor organizations, permittees, and other interested parties; with the full participation of individual technology developers. The program evaluates the performance of innovative technologies by developing test plans that are responsive to the needs of stakeholders, conducting field or laboratory tests (as appropriate), collecting and analyzing data, and preparing peer-reviewed reports. All evaluations are conducted in accordance with rigorous quality assurance protocols to ensure that data of known and adequate quality are generated and that the results are defensible.

The Air Pollution Control Technology Verification Center (APCTVC), one of six centers under the ETV Program, is operated by RTI, in cooperation with EPA's National Risk Management Research Laboratory. The APCTVC has evaluated the performance of a VOC control technology utilizing bioreaction technology for stationary sources, TECHNOLOGY NAME.

VERIFICATION TEST DESCRIPTION

All tests were performed in accordance with general guidance given by the APCTVC’s “Generic Verification Protocol for Bioreaction System Control Technologies for Volatile Organic Compound Emissions” and the specific technology test plan “Verification Test/QA Plan for TECHNOLOGY NAME.” These documents include requirements for quality management, quality assurance, procedures for product selection, auditing of the test laboratories, and test reporting format.

The VOC bioreaction system emission control technology was tested as installed and operating at a field test site using stack test methods. VOC concentrations and/or VOC removal efficiency were measured using the applicable EPA reference test methods. Relevant process variables were monitored using calibrated plant instrumentation.

Tests were conducted to meet primary quality assurance goals of...??..... The verification test is valid only for the stated performance conditions as detailed in the test/QA plan.

A test run consisted of.....

In addition to outlet VOC concentration and the primary process variables, a number of other process parameters of importance for the VOC control technology were also measured using EPA standard methods. In addition, the energy use rates, staffing, maintenance requirements, and similar issues were noted quantitatively or qualitatively, as appropriate for the parameter/measure and the technology being tested.

TECHNOLOGY DESCRIPTION

This verification statement is applicable to the TECHNOLOGY NAME (to include model number and other identifying information as needed)
.....
.....
.....
.....

Control of other (i.e., non-VOC) pollutants is not a topic included in this generic verification protocol.

This verification statement covers application of TECHNOLOGY NAME to xxxxxxxxxxxx stationary VOC sources. TECHNOLOGY NAME is characterized by

 (Descriptive language provided by technology vendor.).....

VENDOR'S STATEMENT OF PERFORMANCE

TECHNOLOGY NAME is capable of achieving a VOC emission reduction efficiency of _____ percent or an emission concentration of _____ ppmv when operated at [specify process operating conditions] and of achieving a VOC emission reduction efficiency of _____ percent or controlling VOC emissions to below _____ ppmv when operated at a [specify different process operating conditions]. (Note that this example statement of performance assumes a single significant parameter. Additional parameters may be required for a particular technology.)

VERIFICATION OF PERFORMANCE

Verification testing of TECHNOLOGY NAME was performed from _____ through _____, at an installation on a xxxxxxxx source in State or Region. The results are given in Table 2.

TECHNOLOGY NAME

Table 2. VOC control performance

| Test Run | Mean Inlet VOC Concentration (ppmv) | Mean Outlet VOC Concentration (ppmv) | Total VOC Mass In (lb/hr) | Total VOC Mass Out (lb/hr) | VOC Removal Efficiency (percent) |
|----------|-------------------------------------|--------------------------------------|---------------------------|----------------------------|----------------------------------|
| 1 | | | | | |
| 2 | | | | | |
| 3 | | | | | |

The APCTVC quality assurance (QA) officer has reviewed the test results and quality control data and has concluded that data quality objectives given in the generic verification protocol and test/QA have been attained.

