

US EPA ARCHIVE DOCUMENT

SRI/USEPA-GHG-VR-12
September 2001

Environmental Technology Verification Report

KMC Controls, Inc.
SLE-1001 Sight Glass Monitor

Prepared by:



Greenhouse Gas Technology Center
Southern Research Institute



Under a Cooperative Agreement With
U.S. Environmental Protection Agency

ETV ✓ ETV ✓ ETV ✓

EPA REVIEW NOTICE

This report has been peer and administratively reviewed by the U.S. Environmental Protection Agency, and approved for publication. Mention of trade names or commercial products does not constitute endorsement or recommendation for use.

Greenhouse Gas Technology Center
A U.S. EPA Sponsored Environmental Technology Verification () Organization



Environmental Technology Verification Report

KMC Controls, Inc.
SLE-1001 Sight Glass Monitor

Prepared By:
Greenhouse Gas Technology Center
Southern Research Institute
PO Box 13825
Research Triangle Park, NC 27709 USA
Telephone: 919/806-3456

Under EPA Cooperative Agreement CR 826311-01-0

U.S. Environmental Protection Agency
Office of Research and Development
National Risk Management Research Laboratory
Air Pollution Prevention and Control Division
Research Triangle Park, NC 27711 USA

EPA Project Officer: David A. Kirchgessner

TABLE OF CONTENTS

	<u>Page</u>
LIST OF FIGURES.....	iii
LIST OF TABLES.....	iii
ACKNOWLEDGMENTS.....	iv
ACRONYMS/ABBREVIATIONS.....	v
1.0 INTRODUCTION.....	1-1
1.1 BACKGROUND.....	1-1
1.2 SLE-1001 SIGHT GLASS MONITOR DESCRIPTION.....	1-2
1.3 TEST FACILITY DESCRIPTION, MODIFICATION, AND CHECKOUT.....	1-6
1.4 OVERVIEW OF VERIFICATION PARAMETERS AND EVALUATION STRATEGIES.....	1-8
1.4.1 SGM Cost and Installation Requirements.....	1-9
1.4.2 Refrigerant Leak Detection Sensitivity.....	1-9
1.4.3 Estimated Potential Refrigerant Savings and Potential Cost Savings.....	1-15
2.0 VERIFICATION RESULTS.....	2-1
2.1 OVERVIEW.....	2-1
2.2 SGM COST AND INSTALLATION REQUIREMENTS.....	2-1
2.3 REFRIGERANT LEAK DETECTION SENSITIVITY.....	2-2
2.3.1 System Refrigerant Evacuation and Leak Checking.....	2-2
2.3.2 SGM Leak Detection Sensitivity.....	2-3
2.4 ESTIMATED POTENTIAL REFRIGERANT AND COST SAVINGS.....	2-7
3.0 DATA QUALITY ASSESSMENT.....	3-1
3.1 DATA QUALITY OBJECTIVES.....	3-1
3.1.1 Leak Detection Sensitivity DQO Reconciliation.....	3-2
3.1.2 Data Completeness DQO Reconciliation.....	3-5
3.2 QA/QC CHECKS FOR NON-CRITICAL MEASUREMENTS.....	3-6
3.3 POTENTIAL REFRIGERANT COST SAVINGS.....	3-7
4.0 TECHNICAL AND PERFORMANCE DATA SUPPLIED BY KMC.....	4-1
5.0 REFERENCES.....	5-1

LIST OF FIGURES

	<u>Page</u>
Figure 1-1	Simplified Diagram of SGM Installation..... 1-3
Figure 1-2	KMC Sight Glass Monitor 1-5
Figure 1-3	Photographs of Test Systems 1-7
Figure 1-4	Refrigerant Leak Detection Sensitivity Testing Procedures.....1-10
Figure 1-5	Refrigeration Gauge Manifold and Hoses1-11
Figure 1-6	Simplified Diagram of Refrigeration Manifold System1-12

LIST OF TABLES

	<u>Page</u>
Table 1-1	Profiles of Test Systems 1-7
Table 2-1	SGM Costs 2-2
Table 2-2a	Rooftop HVAC Full Charge Determinations 2-4
Table 2-2b	Reciprocating Chiller Full Charge Determinations..... 2-4
Table 2-3a	Test Unit Operating Conditions - Rooftop HVAC Unit 2-5
Table 2-3b	Test Unit Operating Conditions - Reciprocating Chiller 2-5
Table 2-4a	Leak Detection Sensitivity at Manufacturer Specified Full Refrigerant Charge..... 2-6
Table 2-4b	Leak Detection Sensitivity with KMC Specified Full Refrigerant Charge 2-6
Table 2-5a	Rooftop HVAC Unit Potential Annual Refrigerant Savings..... 2-8
Table 2-5b	Reciprocating Chiller Potential Annual Refrigerant Savings..... 2-8
Table 3-1	Measurement Instrument Specifications and Data Quality Indicator Goals 3-1
Table 3-2a	Scale Calibration and Precision Data - Rooftop HVAC Unit 3-3
Table 3-2b	Scale Calibration and Precision Data - Reciprocating Chiller..... 3-3
Table 3-3	Summary of Measurement and Leak Detection Sensitivity Errors..... 3-4
Table 3-4a	Rooftop HVAC Data Completeness Goals 3-5
Table 3-4b	Chiller Data Completeness Goals 3-6
Table 3-5	Summary of QA/QC Checks..... 3-6

ACKNOWLEDGMENTS

The Greenhouse Gas Technology Center wishes to thank the following staff of North Carolina State University for their activities in hosting this Verification: Wayne Friedrich, J.C. Boykin, and M. Gonzalez. C. Warren Williams, with Jones Management Services, provided valuable operations support to the test as a certified HVAC technician. The University provided the cooling and refrigeration units that were used during the verification, allowed operations to be altered to support testing, and provided key unit operating information. Thanks are also extended to the members of the GHG Center's Technical Panel Reviewers including Cynthia Gage of U.S. EPA (NRMRL-RTP) and Richard Wells of Brady Services for reviewing and providing input on the testing strategy and this Verification Report.

ACRONYMS/ABBREVIATIONS

CFC	chlorofluorocarbon
DQI	data quality indicator
DQO	data quality objective
EPA	Environmental Protection Agency
ETV	Environmental Technology Verification program
°F	degrees Fahrenheit
FID	flame ionization detector
ft ²	square feet
g	grams
GHGs	greenhouse gases
GHG Center	Greenhouse Gas Technology Center
HCFC	hydrochlorofluorocarbon
HFC	hydrofluorocarbon
hr	hours
in.	inches
KMC	KMC Controls, Inc.
lb	pounds
N ₂	nitrogen
NCSU	North Carolina State University
NIST	National Institute for Standards and Technology
ORD	Office of Research and Development
PFC	perfluorocarbon
psia	pounds per square inch absolute
psig	pounds per square inch gauge
QA/QC	Quality Assurance/Quality Control
QMP	Quality Management Plan
RH	relative humidity
SGM	Sight Glass Monitor
SRI	Southern Research Institute
Test Plan	Test and Quality Assurance Plan
VA	volt amperes

1.0 INTRODUCTION

1.1 BACKGROUND

The U.S. Environmental Protection Agency's Office of Research and Development (EPA-ORD) operates a program to facilitate the deployment of innovative technologies through performance verification and information dissemination. The goal of the Environmental Technology Verification (ETV) program is to further environmental protection by substantially accelerating the acceptance and use of improved and innovative environmental technologies. ETV is funded by Congress in response to the belief that there are many viable environmental technologies that are not being used for the lack of credible third-party performance data. With performance data developed under ETV, technology buyers, financiers, and permittees in the United States and abroad will be better equipped to make informed decisions regarding environmental technology purchase and use.

The Greenhouse Gas Technology Center (GHG Center) is one of several verification organizations operating under ETV. The GHG Center is managed by the U.S. EPA's partner verification organization, Southern Research Institute (SRI), which conducts verification testing of promising GHG mitigation and monitoring technologies. The GHG Center's verification process consists of developing verification protocols, conducting field tests, collecting and interpreting field and other test data, obtaining independent peer review input, and reporting findings. Performance evaluations are conducted according to externally reviewed Verification Test and Quality Assurance Test Plans (Test Plans) and established protocols for quality assurance.

The GHG Center is guided by volunteer groups of stakeholders. These stakeholders offer advice on specific technologies most appropriate for testing, help disseminate results, and review Test Plans and Verification Reports. The GHG Center's stakeholder groups consist of national and international experts in the areas of climate science and environmental policy, technology, and regulation. Members include industry trade organizations, technology purchasers, environmental technology finance groups, governmental organizations, and other interested groups. In certain cases, industry specific stakeholder groups and technical panels are assembled for technology areas where specific expertise is needed. Technical panel members assist in selecting verification factors and provide guidance to ensure that the performance evaluation is based on recognized and reliable field measurement and data analysis procedures. Also, selected members peer review key documents prepared by the GHG Center.

Among the most potent GHGs emitted to the atmosphere through anthropogenic activities are hydrochlorofluorocarbons (HCFCs) and hydrofluorocarbons (HFCs) currently used in most refrigeration and air-conditioning systems worldwide. These chemicals have high global warming potentials and extremely long atmospheric lifetimes, resulting in their essentially irreversible accumulation in the atmosphere (EIA 1997, 1999). In the upper atmosphere, HFCs and HCFCs contribute to the destruction of Earth's protective ozone layer. HCFC-22 (R-22) and HFC-134a are most often used in air-conditioning and refrigeration equipment. Although these refrigerants are maintained in closed systems, some of the refrigerant escapes to the atmosphere during routine installation, operation, and servicing of the equipment. In addition, fugitive emissions escape into the atmosphere from leaky components, resulting in further refrigerant loss. These releases to the atmosphere vary among different types and sizes of equipment and operating practices, and directly contribute to greenhouse gas emissions.

EPA promulgated leak-repair requirements for systems containing CFCs and HCFCs (60 FR 40420) under Section 608 of the Clean Air Act Amendments of 1990. More recently, EPA has proposed another

rule (63 FR 32044) to include substitute refrigerants such as HFCs and perfluorocarbons (PFCs). Under both rules, when refrigerant has leaked in a quantity that exceeds a specified trigger amount from an appliance that normally contains a refrigerant charge of more than 50 lb, the owner or operator of the appliance must take corrective action.

In response to these EPA regulations, manufacturers have made improvements to reduce refrigerant loss through design changes, and new equipment for measuring and detecting leaks has entered the market. KMC Controls, Inc. (KMC), of New Paris, Indiana, and Future Controls, Inc. of Fort Myers, Florida, have jointly developed a leak-monitoring device which allows refrigeration and air-conditioning equipment operators to provide early detection of refrigerant loss. The device, titled the KMC SLE-1001 Sight Glass Monitor (SGM), identifies when a system's refrigerant charge is low and is in need of maintenance and possible repair (including leak repair). This is accomplished using an infrared radiation detector that continuously monitors the presence of flash gas through an existing refrigerant sight glass. The ability of the SGM to detect relatively small levels of refrigerant loss is of significant interest to most users, particularly those facing EPA regulations.

KMC requested that the GHG Center perform an independent third-party performance verification of the SGM on commercial- and industrial-scale refrigeration and air-conditioning systems. SGM performance was verified using air-conditioning and refrigeration systems at North Carolina State University (NC SU). Details on the verification test design, measurement test procedures, and Quality Assurance/Quality Control (QA/QC) procedures can be found in the Test Plan titled *Test and Quality Assurance Plan for the KMC Controls, Inc. SLE-1001 Sight Glass Monitor* (SRI 2001). It can be downloaded from the GHG Center's Web site (www.sri-rtp.com) or from the U.S. EPA Web site (www.epa.gov/etv). The Test Plan describes the rationale for the experimental design, the testing and instrument calibration procedures planned for use, and the specific QA/QC goals and procedures. The Test Plan was reviewed and revised based on comments received from KMC, selected members of the GHG Center's stakeholder groups, and the EPA Quality Assurance Team. The Test Plan meets the requirements of the GHG Center's Quality Management Plan (QMP), and thereby satisfies ETV QMP requirements. In some cases, deviations from the Test Plan were required. These deviations, and the alternative procedures selected for use, are discussed in this report.

The remaining discussion in this section describes the SGM technology, describes the test facility, discusses the verification approach, and lists the performance verification parameters that were quantified. Section 2 presents the verification test results, and Section 3 assesses the quality of the data obtained. KMC provided Section 4 containing additional information regarding the SGM, which has not been independently verified by the GHG Center.

1.2 SLE-1001 SIGHT GLASS MONITOR DESCRIPTION

Heat in refrigeration and air-conditioning systems is transferred by a refrigerant operating in a closed system. Refrigerated systems are primarily designed to cool products, whereas air-conditioning systems cool spaces. Figure 1-1 illustrates a typical air-conditioning system. It consists of four basic components: (1) compressor, (2) condenser, (3) expansion valve or flow controller, and (4) evaporator.

Figure 1-1. Simplified Diagram of SGM Installation

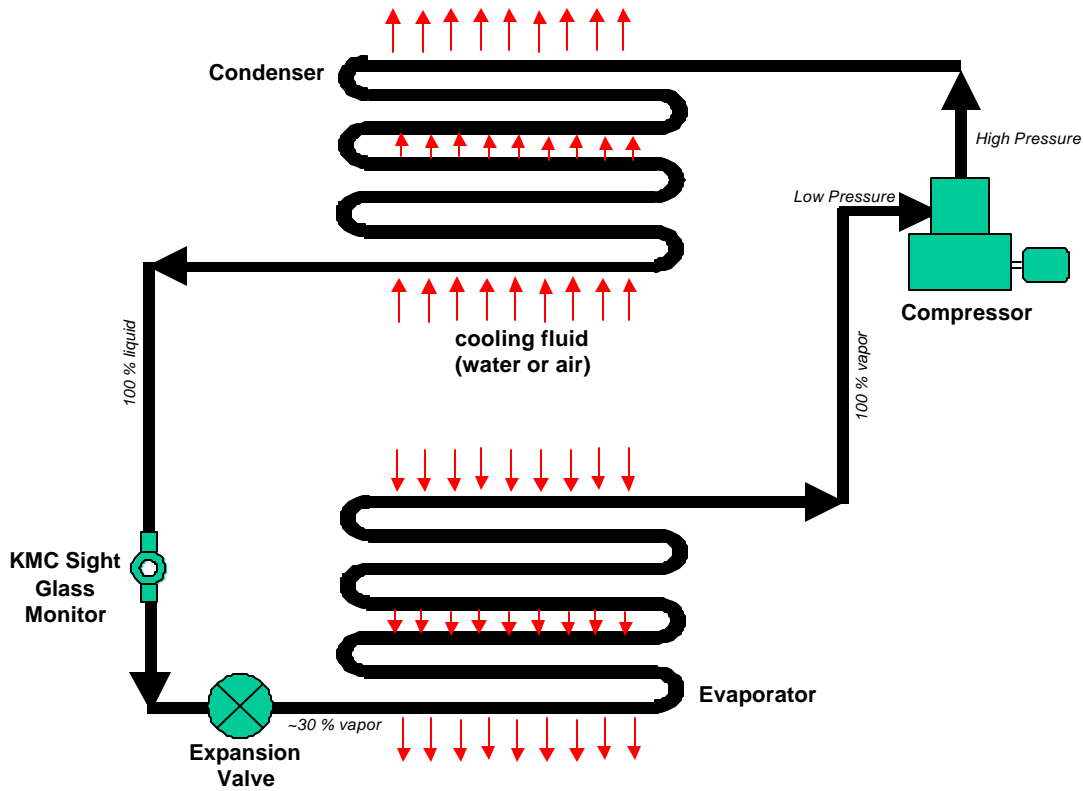

The compressor pressurizes the low-pressure refrigerant vapor, forming hot, high-pressure, superheated vapor. The compressor also provides the motive force needed to circulate the refrigerant through the other basic components and interconnecting piping network of the refrigeration system. The high-pressure vapor discharged from the compressor enters a condenser that cools the refrigerant vapor to a warm, high-pressure, sub-cooled liquid state. The condenser transfers the heat that was contained in the vapor to the external cooling fluid (e.g., water or outdoor air).

The flow controller, often located immediately upstream of the evaporator coils, controls the flow of refrigerant from the condenser to the evaporator. This device acts as a restriction to reduce the pressure of the liquid refrigerant. Several types of flow controllers are used in the industry, with a thermostatic expansion valve being one of the most commonly used controllers. The valve position is pre-adjusted to maintain the optimum amount of refrigerant flow into the evaporator under varying indoor and outdoor temperatures.

The evaporator serves to remove heat from the heat transfer fluid (indoor air or chiller water) passing over it. Inside the evaporator, liquid refrigerant exiting the expansion valve boils and is converted into a vapor as it absorbs heat from the indoor air or water. This cools the refrigerant, the evaporator coils, and the indoor air or water. The cool vapor then returns to the compressor to be recompressed and recirculated. If the incompressible liquid refrigerant reaches the compressor, it can seriously damage the compressor

(slugging). For this reason, all of the liquid refrigerant must be returned to a vapor state prior to leaving the evaporator.

In order for a thermostatic expansion valve to operate properly, it must receive a continuous stream of sub-cooled liquid (10 to 20 °F subcooling) at the proper pressure. To determine if the condenser is supplying liquid refrigerant that meets these requirements, a sight glass is installed in the liquid line to allow visual inspection of the refrigerant condition. Most commercial and industrial equipment is manufactured with a sight glass near the condenser outlet, but ideally, the sight glass should be located as near as possible to the thermostatic expansion valve (*Moravek 2001*).

A clear liquid in the sight glass indicates that there is adequate refrigerant charge in the system to ensure proper feed through the expansion valve. Bubbles in the sight glass, however, can indicate the presence of refrigerant vapor or noncondensables in the liquid line (*Moravek 2001*). A continuous presence of refrigerant vapor or bubbles during compressor operation can indicate that the system is short of refrigerant charge. Noncondensables such as air, nitrogen, or other types of refrigerants not compatible with the system design can also cause bubbles. The presence of these noncondensables can be related to poor refrigerant evacuation activities that result from the operator's failure to completely evacuate air from the system prior to charging. A major restriction in the liquid line, such as a clogged filter, can also result in bubbles in the sight glass due to excessive pressure drop in the line. This restriction causes the refrigerant to boil or flash off to a vapor. Drastic load changes and excessive compressor cycling may also cause bubbles to form. Some sight glasses are equipped with a moisture element inside the sight glass, which can indicate the presence of water.

Despite its intended purpose, the utility of the sight glass as a reliable indicator of low refrigerant charge and moisture levels is often hampered by the relative inaccessibility of the sight glass, and the inability of HVAC technicians to properly interpret sight glass conditions. System operators do not routinely monitor sight glasses during normal daily operations, and may not be aware of bubbles even though they may be present.

The KMC SLE-1001 Sight Glass Monitor (SGM), shown in Figure 1-2, is designed to automatically interpret the condition of the refrigerant and provide operators with audible alarms or remote feedback of actual conditions. The SGM is an external device that is installed on an existing factory-installed sight glass. It is specifically designed to be used with sight glasses marketed by the Sporlan® Valve Company, which provides about 90 percent of sight glasses currently in operation. The SGM monitors two conditions through the sight glass window: bubbles and moisture content. The device emits infrared (IR) radiation which is reflected by bubbles in the refrigerant. When bubbles or flash gases of noncondensed refrigerant are detected in the sight glass, a red light emitting diode (LED) on the monitor housing flashes. The pulse frequency of the red LED increases with increased frequency of bubble detection. The moisture LED changes from green to yellow when moisture is detected in the system. As moisture levels increase, the LED glows brighter in proportion to the degree of moisture detected. In both cases, the SGM provides a 0- to 5-V output that increases proportionally to the red LED flash frequency and the yellow LED intensity. Because the SGM draws its operating power from the existing 24 VAC refrigeration system control circuits, it does not normally require an external power supply.

Figure 1-2. KMC Sight Glass Monitor

Figure 1-2. KMC Sight Glass Monitor

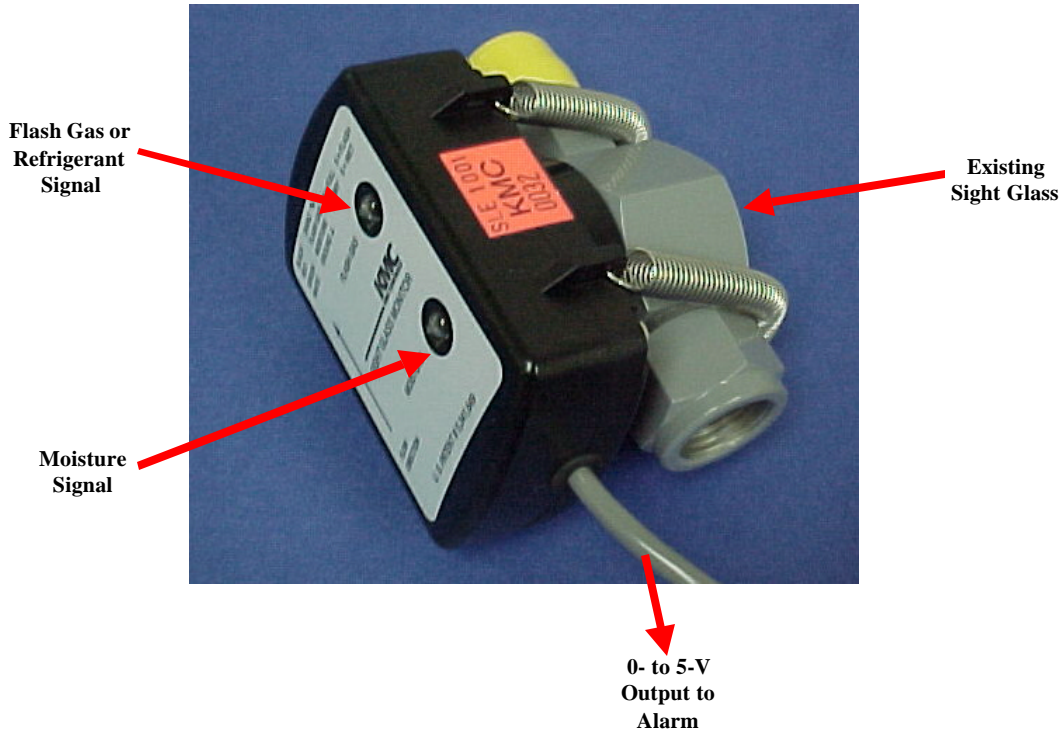

The SGM can be installed on existing systems with 0.25 in. or more clearance surrounding the exterior of the sight glass window frame. The sight glass window must be clear and the side in contact with the refrigerant should not be dark or discolored. The light sensor is placed flush over the sight glass window, and the assembly is held firmly in place with two stainless steel springs that loop around the sight glass' inlet and outlet pipes. Installed in this manner, it is non-invasive and does not require interrupting the HVAC system operation. KMC recommends installing the sight glass and the SGM in a vertical position, with the flow of refrigerant upward through the sight glass. According to KMC, installation in horizontal positions can cause the SGM to be exposed to bubbles that are not associated with low refrigerant charge. To address bubbles formed from restrictions in the line, poor evacuation, or clogged filters, KMC installation procedures specify that operators should maintain clean filters, use manufacturer recommended operational procedures, and follow industry standard evacuation and charging procedures prior to use of the SGM. Also, KMC recommends that operators allow the compressor to run at least 10 minutes to allow the system to equilibrate before interpreting the SGM output.

The system used in this verification consisted of a SGM equipped with a voltage-controlled, relay-actuated timer and annunciator. When the SGM records flash vapor conditions resulting in a greater than 4.0 VDC signal for more than 60 seconds, the annunciator produces a visible and audible alarm. During each test run, the alarm served to notify the verification testing crew that bubbles occurred at the sight glass (i.e., a possible leak indication existed).

The SGM can be applied to a variety of installations which were not used or evaluated as part of this verification. The 0- to 5-V output signal can be wired to the optional KMDigital Controller, which allows

real-time monitoring, logging, and trend analysis of sight glass conditions. The KMDigital Controller is a programmable logic controller intended for integration with building automation systems. It allows inputs from multiple sensors such as temperature probes, thermostats, air velocity, and pressure sensors, and contains additional input channels for signals produced from the SGM. The KMDigital Controller can also deliver data directly or via modem to the optional KMDigital Facilities Management System at a central computer. These options can be set up to page an operator, engage a hardwired relay which sounds an onsite alarm, etc. The Management System allows a certain amount of customization. For example, the backside of the sight glasses may have different shades of reflectivity due to age or overheating during installation. By using engineering adjustments in software, the Management System can reportedly compensate for the different shades of reflectivity in a sight glass per KMC's instruction procedures.

1.3 TEST FACILITY DESCRIPTION, MODIFICATION, AND CHECKOUT

The SGM was verified on a commercial-scale rooftop air-conditioning system and a reciprocating chiller. Both units are owned and operated by North Carolina State University's (NCSU) Centennial Campus in Raleigh, North Carolina. The test systems are representative of the types and sizes of commercial-scale systems to which KMC plans to market the device. KMC has indicated that users can install the SGM and apply the technology to a wide range of sizes and types of equipment. The verification team made reasonable efforts to identify and select representative commercial scale test systems, particularly in sizes which fall under existing EPA regulations. Nevertheless, the test results are limited to the types of systems tested, and may or may not be applicable to other systems (e.g., equipment with centralized receiver tanks).

The Test Plan also specified SGM verification on a supermarket type refrigeration unit. During testing this system was found to be equipped with a head-pressure, flooding control valve in the refrigerant circuit. This valve's location in the circuit prevents bubbles from reaching the sight glass at specific ambient temperatures. KMC indicated that, in its current stage of development, the SGM is not capable of functioning with such a control valve. As a result, the SGM verification on this unit did not occur. Section 2.1 of this report provides more detail regarding the inability to conduct verification testing with this refrigeration unit.

Figure 1-3 presents photographs of the two systems that were used in the verification and Table 1-1 summarizes their key features. A brief description of each system follows.

Figure 1-3. Photographs of Test Systems



Commercial Roof-Top Air-Conditioning System



Reciprocating Chiller

Table 1-1. Profiles of Test Systems

	Commercial-Scale Rooftop HVAC System	Reciprocating Chiller
Manufacturer	Carrier	Carrier
Model	50DKB074DAA600FM	30GT-070-500ka
Cooling Capacity (nominal)	75 tons	70 tons
Number of Compressors	2 (parallel systems)	2 (parallel systems)
Size of Compressors	10 hp each	7.5 hp each
Refrigerant Charge (nominal)	Compressor System A: 73.5 lb Compressor System B: 64.5 lb*	Compressor System A: 70 lb Compressor System B: 69 lb*
Refrigerant Type	R-22	R-22
Refrigerant Operating Pressures (maximum)		
High	410 psig	450 psig
Low	150 psig	278 psig
Nameplate Voltage	460 volts	208/230 volts
Compressor Electrical Data		
RLA ^a (maximum)	65.4 amps	147.7 amps
LRA ^b (maximum)	345.0 amps	690 amps
Condenser Electrical Data		
Number of Fans	5	6
Horsepower	1 hp each	1 hp each
FLA ^c	13.5 amps	37.8 amps
LRA ^b	n/a	186.4 amps
* Test compressor where the SGM was installed and verified		
^a Rated load amps		
^b Locked rotor amps		
^c Full load amps		

Carrier manufactured the rooftop HVAC system selected for testing. This air-to-air exchange unit is a moderately large (75 tons) commercial unit, providing comfort cooling for the tenants of the Research 4 building of the NCSU Centennial Campus. It is one of four identical systems that meet the cooling loads of the approximately 38,000 ft² office building. Records are available listing repairs conducted and refrigerant additions. Each of the two compressors and its associated condenser, evaporator, and valving operates independently from the other. The SGM was installed on the “B” compressor, which is rated for a nominal charge of 64.5 lb R-22 refrigerant.

The chiller system selected for testing uses a reciprocating compressor, and is also manufactured by Carrier. This water chiller is a moderately large (70 tons) system. Similar to the rooftop HVAC unit, it consists of two separate compressors with their associated condensers, evaporators, and valving. Operational and maintenance records are available for this unit. The reciprocating chiller is specified to operate at ambient temperatures from 0 to 125 °F. The maximum water temperature entering the cooler is specified to be 95 °F and the minimum discharge temperature is 40 °F. The SGM was installed on the “B” compressor, which is rated for a nominal charge of 70 lb R-22 refrigerant.

All test systems were previously equipped with factory installed sight glasses. The rooftop air-conditioning unit was factory equipped with a vertically oriented sight glass. No change in glass orientation was required for that unit, but the glass was quite dirty. A certified HVAC technician replaced the sight glass and the inline refrigerant filter/dryer. The technician relocated the reciprocating chiller sight glass from horizontal to vertical position and replaced the inline refrigerant filter/dryer core.

Prior to performance testing of the SGM, each test system was verified to be operating according to the original equipment manufacturers' specifications. This was done to ensure the refrigeration systems were operating representatively, and to prevent potential malfunctions in the test systems which would affect the performance results of the SGM. An independent contractor (Brady Services, Inc.), certified by Carrier to service both Carrier systems, was retained to assess the systems. The certified HVAC technician recorded the following operational parameters and compared them with the manufacturer's specifications:

- Suction and discharge pressures and temperatures
- Liquid line and evaporator temperatures
- Condenser inlet and outlet air temperatures
- Superheat conditions
- Voltages and current draws
- Vacuum leak test results

The assessments occurred during June 2001 under normal operating conditions for both units. The technician confirmed that both units were operating normally within the Carrier specifications, and with no malfunctions. GHG Center representatives were present to observe and document these activities.

1.4 OVERVIEW OF VERIFICATION PARAMETERS AND EVALUATION STRATEGIES

The verification test focused on assessing performance parameters of significant interest to potential future customers of the SGM. The verification addressed the following parameters:

- SGM Installed Cost
- Refrigerant Leak Detection Sensitivity
- Potential Refrigerant Savings and Cost Savings

The following subsections discuss the verification approach, evaluation strategies, and measurement procedures used to conduct the verification. Detailed descriptions of the field measurement instrumentation and procedures are available in the Test Plan and are not entirely repeated here.

1.4.1 SGM Cost and Installation Requirements

Installation and capital costs of the SGM were verified for each test system. Installation of an SGM system includes the following tasks:

1. Installation of a new sight glass (where required per KMC specifications)
2. Installation and configuration of the SGM

The first task requires a certified HVAC technician. An in-house maintenance technician could perform the second task which includes SGM installation and wiring a simple annunciator as was used during the verification testing. The GHG Center obtained or computed actual costs associated for this work which includes the SGM capital cost, parts and supplies for new sight glasses, and equipment costs.

Sight glass installation costs included replacement of the sight glass and filter/drier at the rooftop HVAC unit and relocation/installation of a new sight glass and drier core at the chiller. The GHG Center obtained the actual costs billed for this work from Brady Services, Inc.

Capital costs were verified by obtaining price data from KMC for the SGM, relay actuated timer, and annunciator. KMC also supplied cost data for the optional KMDigital Controller, even though it was not tested or evaluated in this verification. The SGM and timer/annunciator were temporarily installed near the test unit. Permanent installation would require an electrician to run conduit and low voltage (24 VAC) wiring from the unit's low voltage control power supply to the SGM and timer/annunciator. A cost estimate for this activity was obtained from Brady Services, Inc., and is used as the installation cost for the SGM.

1.4.2 Refrigerant Leak Detection Sensitivity

Refrigerant leak detection sensitivity is defined as the percentage of full charge at which, when leaked or removed, the SGM will detect low refrigerant levels, sound an alarm, and provide a visual alarm. To verify this parameter, the GHG Center measured the full charge of each test system, and systematically drew out incremental quantities of refrigerant until a low charge alarm was indicated. The weight of refrigerant withdrawn at the point of monitor alarm, divided by the weight of full charge, times 100 represents the leak detection sensitivity of the monitor.

The charge capacity of each system was quantified by fully evacuating the entire system, and charging the system using the manufacturer's and industry-standard procedures. An HVAC technician, certified as required by the EPA under the Clean Air Act of 1990, §608, as amended, and Title 40 CFR 82, Subpart F, performed all refrigerant handling procedures with the proper equipment .

The following discussion presents the approach used to verify this parameter and a brief description of procedures used. Details regarding refrigerant evacuation and charging on each of the systems can be found in the Test Plan. Figure 1-4 presents a schematic of the key procedures that were followed.

Figure 1-4. Refrigerant Leak Detection Sensitivity Testing Procedures

Figure 1-5. Refrigerant Leak Detection Sensitivity Testing Procedures

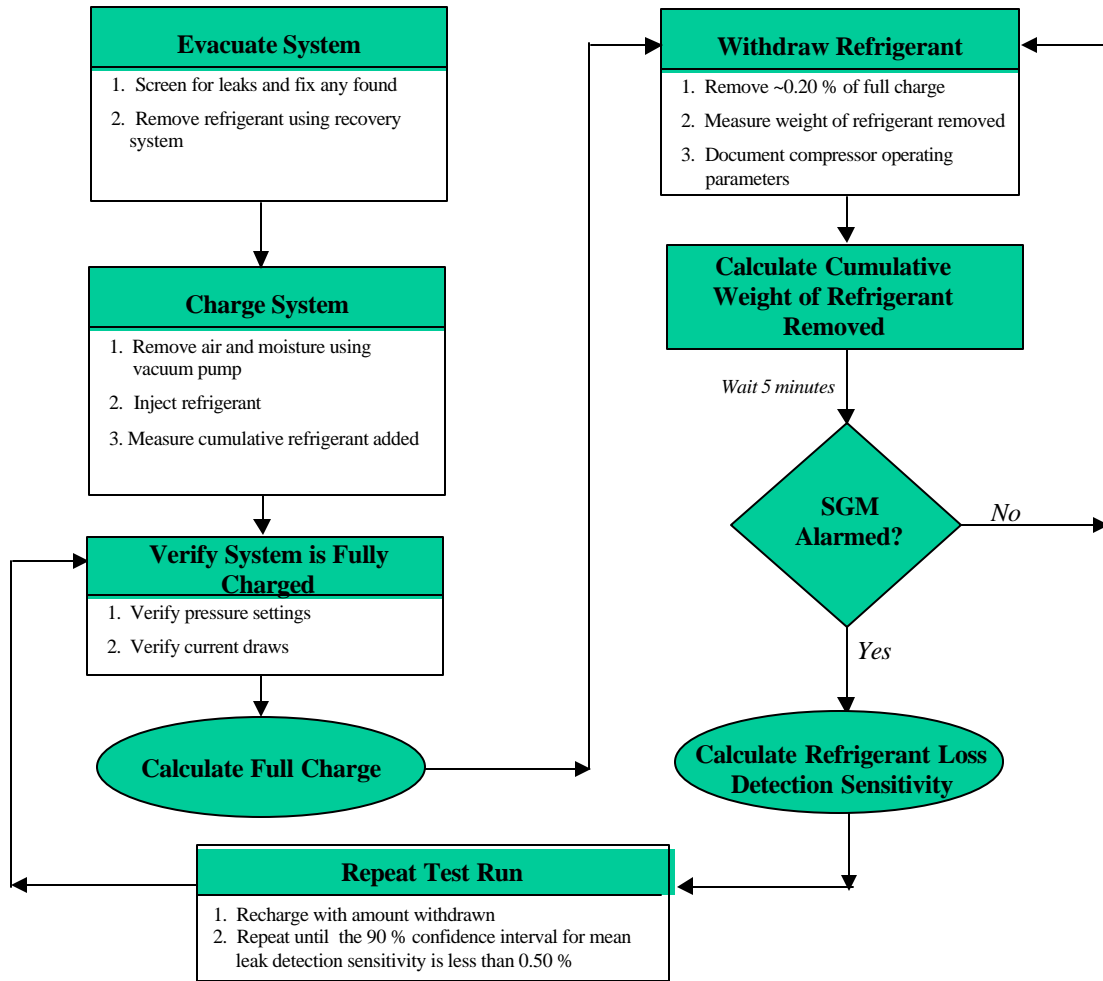

Step 1. Initial System Refrigerant Evacuation

The first step was to evacuate the refrigeration systems after identifying and fixing potential leaks present in the system. Screening for existing leaks in piping, fittings, valves, and other accessories was performed according to industry-accepted methods with a hand-held electronic leak detector. The TIF electronic leak detector complied with ASHRAE Standard 15-1994, which requires the use of an instrument of this type where air-conditioning and refrigeration systems are installed. This detector produces an audible signal (beep), about once/second. The beeps occur faster in the presence of trace amounts of refrigerant. The detector's threshold is approximately 0.5 oz (0.03 lb) of refrigerant per year. Once a refrigerant leak was isolated, NCSU operators fixed the leaks, and verified their repair during normal operation. The leak detector was used as a screening device only, and did not require field calibration.

The systems were then completely evacuated using an EPA-certified refrigerant recovery system and manifold with gauges. The recovery unit is a compact, heavy-duty oilless compressor unit equipped with the appropriate valves and self-sealing quick connects. The recovery unit is connected to a refrigerant

evacuation cylinder and is capable of moving vapor or liquid from either the high or low-pressure side of a refrigeration system into the cylinder. Refrigerant was collected in pre-weighed EPA certified evacuation cylinders (50-lb capacity), and the final weight of the refrigerant-filled cylinders was measured and recorded.

The technician used a vacuum pump to remove air and moisture present in the refrigeration system after the recovery unit had removed the refrigerant. The vacuum pump removed moisture by lowering the pressure within the system and vaporizing the moisture, then exhausting it along with air. Mounted on the vacuum pump is a Thermal Engineering vacuum micron gauge which allows vacuum measurements to be made in microns of Hg. The micron is industry standard nomenclature to record absolute pressures below 29.5 in. Hg. Standard atmospheric pressure is approximately 760,000 microns, or 29.92 in. Hg. The pump can achieve approximately 100 microns maximum vacuum; the micron gauge can indicate to approximately 5 microns vacuum.

After removing moisture and air, the technician performed a vacuum leak check according to standard industry practice. The Test Plan incorrectly stated that the system would be evacuated and held at about 50 microns Hg for this leak check. Standard practice, as outlined in instructions accompanying the vacuum gauge, is to evacuate the system to 500 to 1,000 microns (*Thermal Engineering Company*). The system is then sealed and monitored to verify leak tightness. If the vacuum level remains below 1000 microns for at least 15 minutes, the system is considered to be free of leaks.

Step 2. System Refrigerant Charging

The second step was to recharge each system with refrigerant and determine the full charge capacities. This was done with an industry standard design gauge manifold system. The manifold system is universally recognized as the instrument for testing air-conditioning equipment. It is used for checking operating pressures, adding or removing refrigerant, adding oil, and performing other necessary operations such as leak testing. Figure 1-5 illustrates a gauge manifold system: the HVAC technician used a newly purchased TIF manifold system during the verification tests. Figure 1-6 provides a simplified diagram of the manifold system installed on a refrigeration unit.

Figure 1-5. Refrigeration Gauge Manifold and Hoses



Gauge Manifold

(Source: Imperial Eastman)



Refrigeration Hoses

(Source: Robinaire)

The technician attaches the manifold system hoses to the refrigeration system at factory-installed service valves on the suction and discharge sides of the compressor. Opening and closing the needle valves on the gauge manifold can produce different refrigerant flow patterns and service activities. One indication of proper system function is that the pressure gauge readings are consistent with manufacturer-specified values. Normal pressure readings on an air-conditioning R-22 unit range between 65 and 80 psig pressure on the low side, also called the compound gauge, and 175 to 350 psig on the high side. Actual operating pressures vary depending on the ambient conditions and the load on the refrigeration system. The gauges are constructed such that both pressure and temperature readings can be made simultaneously. Each gauge displays the condensing and evaporating temperatures on their inner rings and pressures on the outer rings. The gauge manifold valves are also manipulated to evacuate and charge the refrigeration system.

Figure 1-6. Simplified Diagram of Refrigeration Manifold System

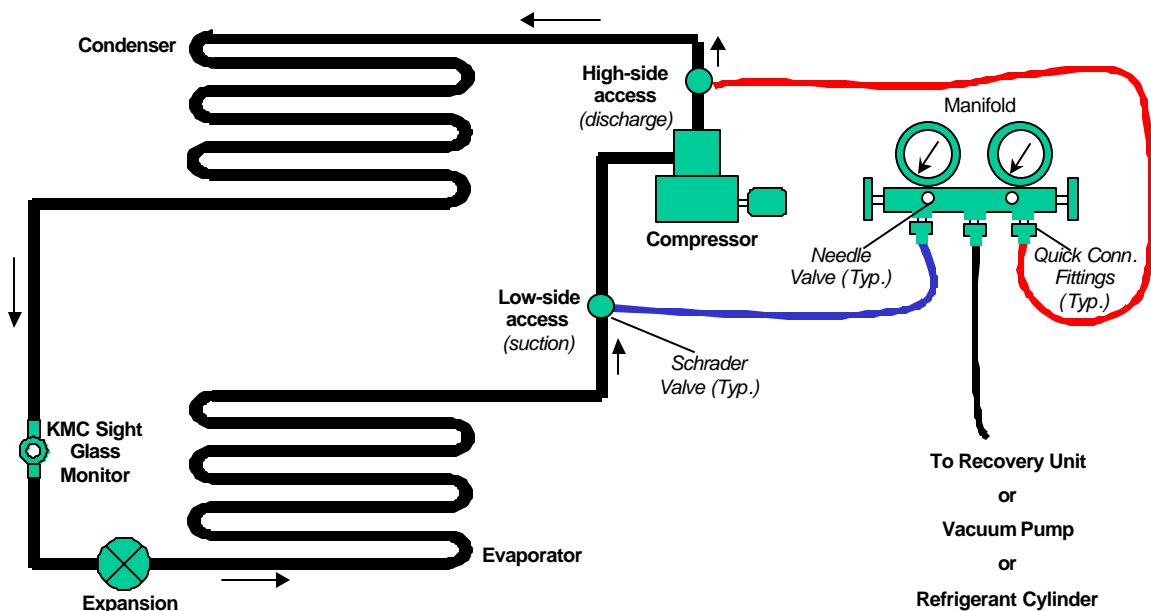

Two definitions of the system full refrigerant charge were addressed during the verification. The Test Plan defined full charge according to industry standard and manufacturer specifications as the amount of refrigerant needed to achieve a visually clear sight glass. The following paragraph discusses this procedure. In addition, the Test Plan described KMC's definition of full charge as the amount of refrigerant needed to achieve SGM flash signals greater than or equal to 4.0 VDC for no more than 15 seconds in any 5-minute period. This report refers to the KMC definition as the voltage/time charging method. The verification results are based on the clear sight glass definition because of its widespread acceptance in the industry and the specifications cited by the test units' manufacturer. It is also used in this verification report to estimate potential cost savings, because users of this technology are likely to be interested in net savings relative to current industry practices. Results based on the voltage/time method are included as additional performance data for readers interested in employing an alternate charging method.

Per Carrier's specifications and industry practice, the technician started charging the system while it was under vacuum. The refrigerant's pressure in the charging cylinder moved the refrigerant into the evacuated system through the gauge manifold until the system and cylinder pressures equalized. The technician then started the unit and continued charging refrigerant while observing the sight glass. As full charge was approached, bubbles would begin to disappear from the sight glass. When the sight glass was running clear, the technician would cease adding refrigerant and observe the sight glass for 3 to 5 minutes. If any bubbles appeared, he would observe the sight glass for an additional 3 to 5 minutes. If any bubbles appeared, he would then add a small amount (approximately 0.2 to 0.5 lb) of refrigerant to the system and repeat the process. When he observed that the sight glass was clear, he declared the system to be charged, and GHG Center personnel recorded the weight of refrigerant that had been supplied to the system. The total charge injected into the system was computed as the difference between the initial and final weight(s) of the charging cylinder(s).

The charging cylinder rested on a digital scale, manufactured by Digimatex, which was used to measure the total charge of each test system and refrigerant withdrawal amounts during leak detection sensitivity testing. The maximum rated capacity of the DI 28 S-SL model is 100 lb, and the rated accuracy is ± 0.02 percent of reading and 0.005 lb display error. The manufacturer's precision (repeatability) specification is ± 0.02 lb. Its platform size is 13 x 17 x 3 in. (length/width/height), large enough to allow the 50- or 30-lb capacity refrigerant cylinders to remain in an upright position. It is battery powered and meets or exceeds Class III and OIML standards. The scale was calibrated with NIST-traceable standard masses less than 1 month prior to the test campaign. GHG Center personnel verified the scale's accuracy immediately before and precision immediately after each test run with NIST-traceable standard masses.

After the system was recharged with refrigerant and was operating normally, the technician and GHG Center test personnel conducted a survey of the gauge manifold, compressor area, condenser area, and evaporator area with the hand-held electronic leak detector. This procedure ensured that the system, gauge manifold, hoses, and test cylinder had no leaks during the test runs.

After achieving the clear sight glass full charge, test withdrawals then commenced, and KMC personnel notified the Field Team Leader when KMC's voltage/time full charge requirement was achieved. For every test run, the amount of refrigerant required to achieve a visually clear sight glass (system manufacturer definition) was larger than the amount needed to achieve KMC's voltage/time definition of full charge. GHG Center personnel recorded the weight of refrigerant that had been withdrawn to determine the voltage/time full charge. The net refrigerant remaining in the system was the full charge as determined by KMC's voltage/time method.

Step 3. Leak Detection Sensitivity Testing

After charging the system, verification of normal system operation was conducted before SGM verification testing was initiated. This process ensured that the refrigeration system operating conditions were consistent between successive leak detection sensitivity test runs, and that the system was fully charged per the manufacturer's recommendations. The current draw of the compressor was measured and recorded, and verified to be operating within manufacturer-specified levels (Table 1-1). High and low manifold pressure gauge readings were monitored and recorded to ensure they did not exceed the manufacturer's specified maximum levels and were within the values expected for the ambient, liquid line, and suction line temperatures observed during the tests. Each test unit's user manual was reviewed to ensure that the measurements were representative and within the expected values for the conditions encountered during testing.

Other parameters monitored during the leak detection sensitivity tests were ambient temperature and relative humidity, and refrigerant suction and liquid line temperatures. Operational parameters were

recorded at the beginning, during, and at the end of each test run. Outdoor temperature and humidity were not critical measurements, but were collected for possible post-test trend analysis and to ensure that the test units were operating representatively. The instrument used was an integrated temperature/humidity unit (Vaisala Model HMP 35A) located in close proximity to the air intake of the condenser. This unit uses a platinum 100-ohm, 1/3 DIN RTD (resistance temperature detector) for temperature measurement. As the temperature changes, the resistance of the RTD changes. The integrated unit uses a thin film capacitive sensor for humidity measurement. The dielectric polymer capacitive element varies in capacitance as the relative humidity (RH) varies, and this change in capacitance is detected. The response time of the temperature and humidity sensors is 0.25 seconds. Its rated accuracy is ± 2 °F for temperature and ± 3 percent for RH. It was wired to a Campbell data logger that was downloaded daily to a laptop computer.

Two type K thermocouples were mounted on the refrigerant suction and liquid lines. The technician inserted the thermocouple probes under the insulation so the sensing element contacted the copper refrigerant line and then taped the probes in place. Test operators plugged the thermocouples into a Fluke two-channel digital thermocouple meter and recorded the resulting temperature readings on the test field data forms. The thermocouples and meter had been calibrated at the GHG Center prior to the start of testing.

After each system was verified to be charged and operating according to manufacturer's recommendations, leak detection sensitivity testing was initiated. To perform these tests it was necessary to have the compressors running continuously while the refrigerant withdrawals occurred. This was accomplished by physically disabling the automatic thermostatic controller which determines whether the compressor turns on or off, and overriding this with manual control. NCSU operators then manually controlled the compressor system as testing proceeded.

Leak detection sensitivity tests were conducted by withdrawing refrigerant from the system in small increments until the sensor alarmed. A pre-weighed, small test cylinder (30-lb capacity) resting on the digital scale was used to collect and quantify the refrigerant withdrawn. The technician connected the liquid port of the test cylinder to the center hose on the gauge manifold. The needle valves on the gauge manifold allowed precise control of small vapor withdrawals (0.10 to 0.30 lb increments) from the high-pressure side of the system under test.

The position of the manifold hose connected to the test cylinder (the yellow hose) and the refrigerant contained in that hose could affect the refrigerant weights determined by the scale. Test operators verified that the manifold hose was undisturbed during each test run. The certified technician ensured that vapor, not liquid, at system suction pressure remained in all hoses at the end of each withdrawal. Under these conditions, the maximum weight of R-22 that could have been contained in the yellow hose (70 inches long x 11/32 inch inside diameter) was 0.004 lb. This is well below the scale's 0.01 lb display resolution and is therefore negligible.

The technician withdrew refrigerant at target increments of about 0.20 percent of the full charge into the pre-weighed test cylinder. The weight of the test cylinder containing the refrigerant was measured and recorded at the end of each withdrawal, using the digital scale. The refrigeration system was allowed to operate for 5 minutes so bubbles generated from removal of the refrigerant were given sufficient time to reach the sight glass area.

The GHG Center personnel waited to determine if an audible alarm occurred. The timer/annunciator was set to produce an audible and visible alarm in response to flash vapor conditions that produced a greater than 4.0 VDC SGM signal for more than 60 seconds. KMC specifies this voltage and duration as an unequivocal signal that the sight glass is filled with flash vapor. When an alarm occurred, the GHG

Center stopped the run, determined the total weight of refrigerant withdrawn, and computed leak detection sensitivity. If the SGM did not alarm to indicate a low charge, another withdrawal (equivalent to the target weight) was made. At the conclusion of each withdrawal, the weight of the test cylinder was measured, and the system was allowed to stabilize for another 5 minutes. During each test, the withdrawal process was repeated until the alarm level was reached. Leak detection sensitivity was computed using Equation 1.

$$\text{Leak Detection Sensitivity (\%)} = \frac{\text{refrigerant lost at the point of monitor alarm (lb)}}{\text{full charge of system (lb)}} \times 100 \quad (\text{Eqn. 1})$$

At the conclusion of each test, the refrigerant was injected back into the system using the equipment and procedures described earlier. The system full charge amount was again determined and recorded. Total full charge for the next run was recorded as the full charge of the previous run, minus refrigerant withdrawn during the previous run's leak detection sensitivity test, plus the refrigerant added to again achieve a clear sight glass.

The Test Plan specified that individual test results must fall within a range of values (confidence interval) around the mean of all test results. Confidence intervals include an estimate of the proportion of test results expected to fall within the given interval (e.g., "90 percent of the individual results are within 0.30 times the mean test result"). The confidence interval depends on the sample standard deviation divided by the square root of the number of samples. For a given standard deviation, a larger number of test results generally tends to reduce the size of the confidence interval. For a data set with a large standard deviation, however, even a large number of tests cannot reduce the size of the confidence interval below certain limits. The Test Plan stated that it was reasonable to expect 90 percent of the observed test results to fall within 0.30 times the mean leak detection sensitivity. This range, or confidence interval, was used to determine the number of tests to conduct on each unit. Test runs were repeated until the confidence interval was less than 0.30 times the mean leak detection sensitivity, or until a maximum of five valid runs had been completed.

During each test, procedures were followed that allowed a minimum of five refrigerant withdrawals before the SGM reached alarm level. The Test Plan specified a target withdrawal rate of 0.2 percent of full charge during each withdrawal, and this value was used as a starting point. As testing progressed, Center personnel were able to fine tune the withdrawal process by increasing the volume of the first few withdrawals and, after nearing the mean alarm point, adjusting the remaining withdrawals to approximately 0.10 to 0.20 pounds each.

The Test Plan required that, for at least one test run at each unit, the wait period between refrigerant withdrawals was to increase to 30 minutes as the alarm point was approached. This was to allow the unit to reach equilibrium and to ensure that the SGM produced a stable alarm condition. Early in the test campaign, the HVAC technician, KMC, and GHG Center personnel concluded that this wait period was excessive. Unit operating parameters and voltage signals from the SGM stabilized in less than 2 minutes after each withdrawal; the consensus was that 5- to 8-minute wait periods between each pair of withdrawals were sufficient.

1.4.3 Estimated Potential Refrigerant Savings and Potential Cost Savings

Operators of refrigeration equipment rely on different inputs to warn of excessive refrigerant loss and, thus, the presence of refrigerant leaks. In extreme cases, catastrophic equipment failure or product loss is the first indication that refrigeration systems require maintenance. More commonly, operators rely on

maintenance records and/or regularly scheduled inspections to indicate when systems require more refrigerant, and when excessive charge loss is occurring. To support wise purchase decisions, operators of refrigeration systems will likely want to know if the SGM can provide potential financial or other benefits compared to currently used methods for detecting refrigerant loss. Both the operator and environment would benefit if the SGM can help operators reduce the amount of refrigerant leaking into the atmosphere. This could occur if the SGM warns of losses more rapidly than currently used detection methods and if system operators respond to SGM alarm conditions (i.e., immediately perform needed repairs).

To assess this, the GHG Center estimated potential refrigerant savings associated with the use of the SGM. This was accomplished by comparing the minimum refrigerant loss detectable by the SGM (determined as described above) with refrigerant losses and outcomes occurring under routine inspection programs. To avoid the cost and time required to determine the sensitivity of routine inspection programs, the GHG Center used historical data maintained by NCSU. The GHG Center obtained operational records for the two test systems and other similar equipment installed at the NCSU campus. System operators maintain these records as a normal industry practice and they serve as a basis for potential refrigerant savings calculations.

The NCSU facilities operators have maintained records since the responsibility for the systems was transferred to them on December 1, 1997. They include:

- Inspection or service/repair date
- Unit ID
- Refrigerant type and fill amounts

For each service record analyzed, the amount of refrigerant replaced since the last full charge (if any) was noted. Analysts reviewed the records for indications of catastrophic losses. Refrigerant recharge after a catastrophic loss would be equal to the unit's capacity; none were noted in the data.

If a properly installed SGM and alarm/annunciator had existed at a given unit, operators would have been alerted to a leak after a certain amount of refrigerant had been lost. This amount depends on the SGM leak detection sensitivity and the unit's refrigerant capacity. For example, if full refrigerant charge at a reciprocating chiller was 46.68 lb of R-22, a 3.56 percent leak detection sensitivity implies that a threshold quantity of 1.66 lb of refrigerant must be lost before an alarm occurs. This approach assumes that the amount of charge lost per unit time (i.e., the leak rate) is constant.

For a given service event, analysts subtracted the threshold quantity from the amount of refrigerant added to the unit. For example, the reciprocating chiller test unit maintenance log recorded 27 lb refrigerant added on September 2, 1998. After subtracting the threshold quantity from the recorded loss, a 25.3 lb savings in refrigerant would have been realized if the leak had been repaired immediately after the SGM alarmed. The price for this refrigerant is currently approximately \$3.75/lb. Using this price, a 25.3 lb savings in refrigerant would equate to a \$95 cost savings for the service event. The potential annual savings is the sum of the potential savings from each service event divided by the number of years of available data for that unit.

2.0 VERIFICATION RESULTS

2.1 OVERVIEW

Verification of the SGM was conducted at NCSU on July 25 through 28, 2001. KMC supplied the SGM with a voltage-controlled, relay-actuated timer/annunciator. KMC personnel installed it on the two test units immediately before testing commenced.

The Center had also planned to test the SGM on a third unit: a supermarket-type refrigeration system. The unit's manufacturer, however, (Larkin) noted that this unit was equipped with a head pressure control flooding valve. This valve reroutes the refrigerant at moderate ambient temperatures (less than approximately 78 °F) and prevents bubbles from reaching the sight glass until virtually all the refrigerant is removed from the unit. An initial test run confirmed this. The SGM technology as it stands is not designed to operate when the valve is actuated, preventing bubbles from reaching the sight glass. Based on this consideration, KMC and the GHG Center concluded not to test the supermarket unit as configured.

Results for the primary verification parameters are discussed in the following subsections:

- Section 2.2 – SGM Installed Costs
- Section 2.3 – Refrigerant Leak Detection Sensitivity
- Section 2.4 – Potential Refrigerant Savings and Cost Savings

2.2 SGM COST AND INSTALLATION REQUIREMENTS

Table 2-1 presents a summary of as-tested SGM capital and installation costs. KMC provided capital costs for the SGM and the timer/annunciator, as used during the verification. The total capital cost for the entire system is \$360.00.

KMC installed the SGM and timer/annunciator on the test units temporarily to allow easy relocation. Potential purchasers of the device can elect to install the timer/annunciator at the SGM (i.e., near the refrigeration system compressor) or at a remote location. In both cases, a permanent installation would require low voltage wiring for the SGM and timer/annunciator, conduit, connection with the unit's control circuit power supply, and the associated labor charges. For a permanent timer/annunciator installation at the SGM location, Brady Services, Inc. estimated the cost as approximately \$170.00. Total installed cost for the SGM and the timer/annunciator is \$530.00 for both units.

Table 2-1. SGM Costs		
<i>SGM Capital Costs</i>		
Description	Rooftop HVAC	Chiller
SGM	\$210.00	\$210.00 ^a
Voltage-controlled relay and timer/annunciator cost estimate	\$150.00 ^B	150.00 ^{a, b}
<i>SGM Subtotal</i>	<i>\$360.00</i>	<i>\$360.00</i>
<i>SGM Permanent Installation Cost Estimate</i>		
Parts and labor: wire, conduit, connection to existing low-voltage power supply in unit	\$170.00	\$170.00
Total SGM Installed Cost <i>(with existing sight glass)</i>	\$530.00	\$530.00
<i>Capital and Installation Costs for Modifying Existing Sight Glass</i>		
Sight glass	\$18.00	\$18.00
Misc. piping and supplies	\$25.00	\$25.00
Inline filter/dryer	\$26.00	\$20.00
Welding supplies	\$12.50	\$12.50
Refrigerant recovery equip. charge	\$12.50	\$12.50
Service call	\$12.50	\$12.50
Certified HVAC contract labor	\$132.00	\$132.00
<i>Sight Glass Subtotal</i>	<i>\$238.50</i>	<i>\$232.50</i>
Total SGM Installed Cost <i>(with new sight glass)</i>	\$768.50	\$762.50
^a One SGM and timer/annunciator was used for all verification tests. KMC relocated the equipment to the chiller unit immediately prior to the start of testing at that unit ^b KMC's cost for the as-tested shop-built timer/annunciator was \$225.00. In normal production, KMC estimates this device would cost \$150.00.		

As stated in Section 1, the sight glass and inline drier on the rooftop HVAC unit were replaced. For the chiller, the sight glass was relocated to a vertical position and the drier core was replaced. This work brought the sight glasses into conformance with KMC specifications on the test units. These modifications may or may not be required at other installations, depending on the condition and orientation of existing sight glasses. As shown in Table 2-1, the total installed costs for an SGM with a new sight glass increase by \$238.50 for the HVAC unit and \$232.50 for the chiller.

KMC also supplied the price for the KMDigital controller, even though it was not involved with the verification tests. The price for the optional KMDigital controller is \$160.00.

2.3 REFRIGERANT LEAK DETECTION SENSITIVITY

2.3.1 System Refrigerant Evacuation and Leak Checking

Refrigerant leak detection checking was conducted on the rooftop air-conditioning system and the reciprocating chiller after installation of the SGM. Before initiating leak detection checks, both systems

were fully evacuated of refrigerant and checked for leaks using the procedures specified in the Test Plan and Section 1.4.2 of this report.

After removing as much of the refrigerant as was possible from the rooftop system with the recovery unit, the technician evacuated the system to 505 microns vacuum with a high vacuum pump. After a 15-minute hold time, the vacuum gauge indicated 490 microns. These results were satisfactory and indicated a leak-tight system. The slight increase in vacuum was normal and due to pressure equalization throughout the system (*Thermal Engineering Company*).

After the system was recharged with refrigerant and was operating normally, the technician and GHG Center test personnel conducted a survey of the gauge manifold, compressor area, condenser area, and evaporator area with the electronic leak detector. No leaks were found.

At the reciprocating chiller, GHG personnel had surveyed the evaporator and condenser areas with the electronic leak detector while the system was operating normally. Then, after shutting the system down and removing as much of the refrigerant as was possible with the recovery unit, the technician installed a high vacuum pump onto the system and let the pump operate overnight. In the morning, vacuum level was at about 800 microns. When the technician shut off the vacuum pump, the gauge indication immediately began to rise towards 1,000 microns. The technician suspected that the indicated leak may be in the vacuum pump, and not in the chiller. He closed the gauge manifold valves, thus isolating the manifold gauges and the system from the vacuum pump and its micron gauge. Over the next 60 minutes, the vacuum pump and micron gauge leaked back to atmospheric pressure while the reciprocating chiller unit remained at 30 in. Hg vacuum (as indicated by the manifold gauges). This standard practice indicated that the leak was in the vacuum pump and/or its micron gauge, not the test unit.

The technician recharged the system, brought the reciprocating chiller online under normal operating conditions, and surveyed the compressor area, gauge manifold, and test cylinder areas with the electronic leak detector. Three small leaks were found at gauge pressure ports and were corrected by tightening the fittings approximately one-quarter turn.

2.3.2 SGM Leak Detection Sensitivity

System Refrigerant Charging

As discussed in Section 1.4.2, two definitions of system full refrigerant charge were addressed during the verification. The Test Plan defined full charge according to manufacturer (Carrier) specifications as the amount of refrigerant needed to achieve a visually clear sight glass. In addition, the Test Plan includes KMC's voltage/time definition of system full refrigerant charge. The field testing revealed that these two conditions did not result in the same full charge determination for these systems. More refrigerant was needed to achieve a visually clear sight glass (system manufacturer definition) than the amount needed to achieve the KMC definition of full charge.

Since system full charge is the denominator in the equation used to calculate leak detection sensitivity (Equation 1), the verified full charge value for each of the systems has a direct impact on the verification results. To address this, the Center calculated leak detection sensitivity using full charge capacities determined using both definitions. The full charge determinations based on the manufacturer's clear sight glass definition were used to calculate leak detection sensitivity as discussed in Section 1.4.2. These data form the basis to estimate potential annual refrigerant and cost savings because potential users of this technology are likely to be interested in potential savings based on the manufacturer's standard full charge methodology.

Test withdrawals commenced after full charge was achieved according to the clear sight glass specification. KMC personnel notified the Field Team Leader when the KMC definition of full charge was achieved. The full charge determinations using the KMC definition are presented here to provide potential SGM users with data on the differences in full charge capacity that may occur if they choose to employ the KMC procedures. Tables 2-2a and 2-2b present the verified full refrigerant charge amounts for both systems tested using the two different definitions of full-refrigerant charge.

Table 2-2a. Rooftop HVAC Full Charge Determinations		
Test Number	Clear Sight Glass Method (lb)	KMC Voltage/ Time Method (lb)
1	51.74	n/a ^a
2	49.72	n/a ^a
3	52.35	51.21
4	52.35	50.78
5	52.37	50.76

^a Data for these two runs were not recorded because the full charge determination strategy was under discussion and had not yet been approved by KMC and the GHG Center.

Table 2-2b. Reciprocating Chiller Full Charge Determinations		
Test Number	Clear Sight Glass Method (lb)	KMC Voltage/ Time Method (lb)
1	47.10	45.40
2	47.12	45.20
3	46.25	45.25
4	46.25	45.27
5	46.68	45.20

Test Conditions

During each test run, system operational conditions were documented including current draw, compressor suction and discharge pressures, and refrigerant liquid and suction temperatures. These data were recorded at the beginning and end of each test conducted. Ambient temperature and humidity were recorded at 1-minute intervals during the test periods. System operational data and average ambient conditions during each test run are summarized in Tables 2-3a and 2-3b.

These data are presented to document that system operations were representative of normal operations throughout the test periods and that conclusions presented in this report are based on withdrawal of refrigerant rather than system operational changes or upsets.

Table 2-3a. Test Unit Operating Conditions- Rooftop HVAC Unit

Run	Average Current Draw (amperes)		Gauge Pressure (psig)				Refrigerant Temperature (°F)				Ambient Temp (°F)	Relative Humidity (%)
			High Side		Low Side		Liquid Line		Suction Line			
	Start	End	Start	End	Start	End	Start	End	Start	End		
1	62.93	61.30	215.0	205.0	54.0	50.0	90.8	90.4	80.6	80.0	89.9	55.2
2	60.07	58.90	205.0	199.0	50.0	48.0	91.8	88.6	80.8	80.2	86.9	60.9
3	57.27	57.67	180.0	180.0	41.0	41.0	73.0	72.4	56.8	58.1	70.1	89.9
4	58.13	57.93	180.0	180.0	43.5	42.5	74.6	73.8	59.4	62.4	70.5	87.9
5	58.67	59.03	185.0	190.0	45.0	44.0	74.8	76.2	60.6	62.8	72.8	78.9

Table 2-3b. Test Unit Operating Conditions - Reciprocating Chiller

Run	Average Current Draw (amperes)		Gauge Pressure (psig)				Refrigerant Temperature (°F)				Ambient Temp (°F)	Relative Humidity (%)
			High Side		Low Side		Liquid Line		Suction Line			
	Start	End	Start	End	Start	End	Start	End	Start	End		
1	125.50	122.63	223.0	223.0	55.0	55.0	99.4	99.4	53.2	52.8	83.1	45.8
2	124.33	123.50	225.0	220.0	54.5	52.5	97.8	100.0	51.4	51.2	83.0	40.1
3	122.63	122.33	228.0	224.0	55.0	53.5	101.4	100.6	50.8	51.0	83.0	43.5
4	124.07	122.93	224.5	220.5	54.0	54.0	100.2	98.6	51.0	50.6	84.7	42.9
5	130.07	122.77	224.5	218.0	54.0	54.0	98.6	98.6	50.4	50.8	82.5	46.1

Review of the field data and manufacturer’s specifications showed that the systems were operating normally at the conditions encountered during testing. For example, Figures 58 and 59 in Carrier’s “Installation, Start-up and Service Instructions” manual (No. 564-818) present the typical range of suction and discharge pressures as a function of ambient temperatures for the rooftop unit (Carrier 1996). The manifold gauge readings shown in Table 2-3a are consistent with these data. For example, higher pressures are expected while operating during warmer temperatures. The manuals for the reciprocating chiller do not contain these types of guidelines for pressures. Based on general operational parameters outlined in the book *Refrigeration and Air-Conditioning* (ARI 1987), the pressures observed are indicative of normal unit operation.

NCSU’s technician induced a suitable building load for the rooftop unit by commanding the heating system to operate at the same time as the air-conditioning system. For the reciprocating chiller, existing building loads were sufficient to allow the reciprocating chiller to operate continuously during all tests. Average current draws were 90.5 and 84.0 percent of the rated full load specification for the rooftop HVAC and reciprocating chiller units, respectively (Table 1-1). This indicates that both units were operating in a representative manner during all test runs.

Leak Detection Sensitivity Results

The leak detection sensitivity tests were conducted after full refrigerant charges were achieved and the systems were verified to be operating normally and properly. In general, precise portions of refrigerant (0.10 to 0.30 lb increments) were removed from the systems until the SGM alarm level was reached. The

certified HVAC technician controlled refrigerant withdrawals with the needle valves on the gauge manifold, and the amount of refrigerant withdrawn during each step was measured using the calibrated scale and recorded.

Results of the leak detection sensitivity tests are presented in Tables 2-4a and 2-4b. Table 2-4a presents test results for both systems with full charge procedures conducted in accordance with manufacturer specifications (clear sight glass procedure). These data are used to estimate potential refrigerant and cost savings in the following section. The results presented in Table 2-4b represent leak detection sensitivities on both units as determined using the KMC voltage/time full charge procedures.

Table 2-4a. Leak Detection Sensitivity at Manufacturer Specified Full Refrigerant Charge (clear sight glass)			
Rooftop HVAC Unit			
Run	Total Refrigerant Withdrawn (lb)	Leak Detection Sensitivity (%)	Average and 90% Confidence Interval
1	3.43	6.63	5.09 ± 1.01 %
2	1.86	3.74	
3	2.42	4.62	
4	2.78	5.31	
5	2.70	5.16	
Reciprocating Chiller			
1	2.13	4.52	3.56 ± 0.88 %
2	2.10	4.46	
3	1.27	2.75	
4	1.17	2.53	
5	1.65	3.53	

Table 2-4b. Leak Detection Sensitivity with KMC Specified Full Refrigerant Charge (voltage/time method)			
Packaged Rooftop HVAC Unit			
Run	Total Refrigerant Withdrawn (lb)	KMC Adjusted Leak Detection Sensitivity (%)	Average and 90% Confidence Interval
3	1.86	3.63	2.72 ± 1.34 %
4	1.21	2.38	
5	1.09	2.15	
Reciprocating Chiller			
1	0.43	0.95	0.55 ± 0.23 %
2	0.18	0.40	
3	0.27	0.60	
4	0.19	0.42	
5	0.17	0.38	

Following manufacturer specifications for system charging procedures, the average leak detection sensitivity performance of the SGM on the rooftop HVAC and reciprocating chiller systems were 5.09

and 3.56 percent of full charge, respectively. This corresponds to average refrigerant losses of 2.64 and 1.66 lb on the two systems.

It is instructive to relate these results to the EPA regulations which apply to commercial refrigeration units. The current Rules (for system refrigerant capacities greater than 50 lb), limit annual leaks to 35 percent of the unit's capacity or approximately 18.10 lb per year for the rooftop HVAC unit. EPA has proposed a Rule at 63 FR 32044 (June 11, 1998) which would reduce the allowable annual leaks to 10 percent of the unit's capacity, or approximately 5.17 lb for this unit. Based on these verification results, the SGM could be an important tool to assist facilities in complying with either Rule. This is because system operators could respond to and repair refrigerant leaks well before approaching the regulated leak amounts.

The leak detection sensitivities quoted here apply only to these two 70 to 75 ton (nominal) capacity reciprocating units using R-22 refrigerant and tested under the ambient conditions found during the test campaign. Extrapolation of the verification results to other units with different compressor designs, capacities, refrigerants, and ambient conditions may not be valid.

2.4 ESTIMATED POTENTIAL REFRIGERANT AND COST SAVINGS

The SGM leak detection sensitivity results obtained during the field verification testing were used to estimate potential refrigerant savings (reduction of refrigerant losses through leaks). This analysis was conducted by determining refrigerant losses via current industry operating and maintenance practices. This consisted of obtaining historical system maintenance data from the test units and other similar systems at NCSU. The measured leak detection sensitivities were applied to refrigerant losses reported in the maintenance logs to determine the savings that could have occurred with use of the SGM. The analysis includes a total of 13 service event reports from the systems tested (11 for the reciprocating chiller and 2 for the rooftop HVAC system) and 16 entries from HVAC and reciprocating chiller units similar to those tested.

This analysis was conducted using the average leak detection sensitivities as determined using the manufacturer's definition of system full charge and summarized in Table 2-4a (i.e., 5.09 percent for the HVAC system and 3.56 percent for the reciprocating chiller). Additional savings could be realized if an operator chose to define system full charge using the KMC voltage/time procedure. As outlined in section 1.4.3, a threshold refrigerant loss based on the leak detection sensitivity and the unit's full charge capacity was subtracted from each service event to yield the potential refrigerant (and cost) savings. The sum of the potential savings divided by the years of record is the potential annual savings. Responsibility for the equipment analyzed was transferred to the NCSU maintenance contractor on December 1, 1997. This is taken as the starting date for the analysis, and represents the initial point at which each system contained full refrigerant charge before the analyzed service events.

All units analyzed use R-22 refrigerant. Many units have multiple compressors and refrigerant circuits. It was often impossible to apportion a logged refrigerant addition to a specific circuit: the log entries mention only the unit being serviced. In these cases, the analysis treats each log entry as a separate service event. This approach is conservative, because it applies the threshold loss to each service event and will tend to under-predict the potential savings. Another important assumption in this analysis was that system leaks would be repaired immediately after the threshold was reached and the SGM alarmed. Delays in responding to SGM alarms will reduce potential refrigerant and cost savings realized by an operator.

Tables 2-5a and 2-5b summarize the potential savings in refrigerant and costs for each of the units examined. The tables summarize analyses of maintenance records from the two test units, as well as

records from four other rooftop packaged HVAC units manufactured by McQuay, and a York reciprocating chiller. For simplicity, the tables quote the units' nominal refrigerant capacities as the clear sight glass full charge. Note that accurate full charge data for the McQuay and York units can only be obtained via the clear sight glass full charge determination procedures described in the Test Plan.

Table 2-5a. Rooftop HVAC Unit Potential Annual Refrigerant Savings

Unit Description	R-22 Full Charge (lb)	Total Number of Service Events	Years of Record	Total Potential R-22 Savings (lb)	Verified SGM Leak Detection Sensitivity (%)	
					5.09	
					Potential Annual Savings	
					lb of Refrigerant	Dollars
*Carrier Rooftop HVAC	51.71	2	1.5	11.7	7.8	\$29
McQuay Packaged Unit	56	3	3.5	30.8	8.8	\$33
McQuay Packaged Unit	88	3	1.6	0	0	\$0
McQuay Packaged Unit	56	5	3.6	9.0	2.5	\$9
McQuay Packaged Unit	56	2	1.6	7.1	4.4	\$17

* Unit tested during this Verification

Table 2-5b. Reciprocating Chiller Potential Annual Refrigerant Savings

Unit Description	R-22 Full Charge (lb)	Total Number of Service Events	Years of Record	Total Potential R-22 Savings (lb)	Verified SGM Leak Detection Sensitivity (%)	
					3.56	
					Potential Annual Savings	
					lb of Refrigerant	Dollars
*Carrier Chiller	46.68	11	1.5	205.9	137.3	\$515
York Chiller	70	3	1.5	74	49.3	\$185

* Unit tested during this Verification. This unit shows a high number of refrigerant losses per year as compared to the York chiller and the rooftop HVAC units, which may indicate system problems.

These estimates demonstrate that savings in refrigerant needed to maintain system full charge and associated costs can vary greatly depending on the condition of the system and the number of maintenance activities needed to maintain proper operation. The highest annual usage (or leakage) for the HVAC systems examined was 8.8 lb per year. Conversely, the reciprocating chiller used for this verification required over 200 lb of refrigerant to be added over the 1.5 years of record. Systems with a history of leaks or other operational problems could realize substantial savings through installation of an SGM, provided alarm responses are timely. The chiller test unit, however, is an example of a system at which operators may not realize the full potential savings. It could be difficult for a service organization to respond to recurring alarms (11 over 18 months) in a timely manner. For this unit, the potential savings in Table 2-5b could be overestimated.

Proper use of and response to an SGM may provide cost savings by improving system operation and efficiency. It is likely that a fully charged HVAC or reciprocating chiller system will operate more

efficiently than an undercharged or overcharged system, although cost savings of this nature were not analyzed during this study. It is also possible that certain scheduled refrigerant maintenance activities could be eliminated by SGM installation. These include routine sight glass observations, electronic leak detection surveys, and gauge manifold installations for checking refrigerant full charges. Some facilities, however, include these maintenance checks in quarterly system inspections (i.e., technicians perform other system diagnosis and preventive maintenance at the same time). NCSU follows this practice, and may not realize savings from the avoided labor for sight glass observations, etc.

The GHG Center recognizes that several factors may contribute to uncertainties in the historical data and thus, in this evaluation. Examples of confounding factors in the historical data include: (1) refrigerant service provider rounding-off the amount of refrigerant added, (2) pressure gauge or other instruments used to monitor charge loss and amount added could have malfunctioned, (3) gauge manifold and other charging equipment were not completely screened for leaks, (4) data transcription errors occurred, and/or (5) the technician's weighing scale was not calibrated.

The age of a particular unit will affect the available data. For example, a brand new unit may not have any leaks for a long time during which an SGM could alarm. As it ages and begins to leak, however, an SGM would then begin to track and alarm the leaks. It is also possible that system operators would not respond to SGM alarms in a timely fashion, thereby not realizing the full potential savings, or that they would simply recharge a system without performing repairs. Finally, the historical data contain a limited population of systems, all managed by one operator. It is beyond the scope of this verification to quantify all of the uncertainties associated with each factor. Thus, the potential savings reported here represent the maximum potential savings for the systems operated by this facility.

3.0 DATA QUALITY ASSESSMENT

3.1 DATA QUALITY OBJECTIVES

In verifications conducted by the GHG Center and EPA-ORD, measurement methodologies and instruments are selected to ensure that a desired level of data quality occurs in the final results. The primary verification parameter for this verification was leak detection sensitivity. Other verification parameters (installation costs and requirements and potential refrigerant savings) did not require physical measurements or instrumentation. Therefore, the Test Plan specified a DQO for leak detection sensitivity only.

Leak detection sensitivity was measured by weighing incremental refrigeration losses and total unit charges. Therefore, weight measurement errors would significantly affect the quality of the data used to determine this verification parameter. The test plan presented the chain of calculations performed to assess the effects of scale accuracy on leak detection sensitivity determinations. The calculations show that, for the units tested during this verification, if the assumed weighing scale errors occur during a test that yields a 1.00 percent leak detection sensitivity, actual leak detection sensitivity could range between 0.980 and 1.02 percent. This is a 0.02 percent deviation from the true value of 1.00 percent, and represents a 2.00 percent error in the determination of the leak detection sensitivity. This error was the basis for the leak sensitivity detection DQO that was specified at ± 2 percent in the Test Plan

To determine if the DQO was met, data quality indicator goals (DQIs) were established for key measurements performed during testing. In this case, the primary DQI was the accuracy of the scale used to measure refrigerant charging and withdrawal weights. These goals, summarized in Table 3-1, identified accuracy and precision DQIs for the scale that must be met to achieve the overall DQO. The following section discusses the use of field calibration results to reconcile the DQO.

Table 3-1. Measurement Instrument Specifications and Data Quality Indicator Goals					
Measurement Variable	Instrument Type / Manufacturer	Instrument Range	Instrument Specification		How Verified / Determined
Full charge and refrigerant withdrawal measurements	Digi Model DI-28, S-SL Bench	0 to 100 lb	Accuracy	$\pm 0.02\%$ of reading and ± 0.005 lb display error	Factory calibration
			Precision	± 0.02 lb	Pre-test field calibrations ^a - before each run Post-test field calibrations ^b - replicate weighings after each test run
^a Scale readings were compared with the following NIST-traceable standard masses: 5, 10, 15, 20, 25, 30, 50, 75, and 100 lb (nominal) ^b Scale readings were compared with four NIST-traceable standard masses that represented weights measured during test run					

3.1.1 Leak Detection Sensitivity DQO Reconciliation

Two newly purchased scales were used during the verification test. The first scale malfunctioned after the second test run at the rooftop HVAC unit. The GHG Center field team obtained a second scale for the balance of the test runs. The distributor provided NIST-traceable calibration certificates for both scales. These certificates are maintained at the GHG Center, and certify that both scales initially met the accuracy and precision criteria listed in Table 3-1.

In addition to factory certification, GHG Center personnel conducted accuracy determinations before and precision determinations after each test run using the following NIST-traceable standard masses:

<u>Nominal Weight, lb</u>	<u>NIST-Certified Weight, lb</u>
5	5.000117
10	10.00025
15	15.00037
20	20.00096
25	25.00108
30	30.00145
50	50.00206
75	75.00314
100	100.0045

Prior to each test run, the test operator challenged the scale with each weight and recorded the display reading on field data log forms. Precision was verified in the field, at the end of each test run, by performing replicate weighings using four of the NIST-traceable standard calibration weights that were representative of the actual weights observed during that test run. Each of these four weighings was repeated twice at the end of each run to confirm that precision was within 0.02 lb. Tables 3-2a and 3-2b present the pre- and post- test field verification results. The maximum deviation in precision measured was 0.02 lb, so the scale met the GHG Center’s 0.02 lb precision goal.

To satisfy the accuracy goal, the Test Plan specified the scale reading be within ± 0.02 percent of standard mass plus 0.005 lb display error. For a 20 lb standard mass, the calibration must result in a reading that ranged between 19.991 and 20.009 or ± 0.009 lb ($20 \times 0.02\% + 0.005$). The digital display on the scale was such that measurements are shown only to two decimal places, not three as needed to assess the accuracy requirement. The two-digit display is programmed such that the weights are rounded to the nearest 0.01 lb. In the example above, the scale would display between 19.99 and 20.01 lb (i.e., error of ± 0.01 lb not ± 0.009 lb), which (technically) would result in exceeding the accuracy goal. Based on this, it was concluded that precise verification of scale accuracy could not be performed in a straightforward manner. In retrospect, the accuracy goal in the Test Plan should have been made consistent with the two-digit display capability of the scale.

Nevertheless, the pre-test and post-test calibration results shown in Tables 3-2a and 3-2b suggest the scales performed well. The maximum difference displayed between a measured weight and any standard mass was 0.02 lb, and in most cases, the difference was less than 0.01 lb. The Center has used these field calibration results to compute potential leak detection sensitivity errors due to scale error. Specifically, calibration results between the scale readings and NIST weights are used to compute errors in full charge and refrigerant withdrawal measurements. These errors are then propagated to compute actual leak detection sensitivity errors reported for each test run.

Table 3-2a. Scale Calibrations and Precision Data - Rooftop HVAC Unit

NIST Standard Mass	Run 1			Run 2			Run 3			Run 4			Run 5		
	Pretest Calibration	Post-test Precision		Pretest Calibration	Post-test Precision		Pretest Calibration	Post-test Precision		Pretest Calibration	Post-test Precision		Pretest Calibration	Post-test Precision	
5.00	5.00			4.99			4.99			5.00			5.00		
10.00	10.01	10.02	10.02	9.99	9.99	9.98	10.00			10.00			10.00		
15.00	15.00	15.02	15.02	14.99	14.99	14.98	14.99			15.00			15.00		
20.00	20.00	20.02	20.02	20.00	19.99	19.98	19.99	20.00	20.00	20.00	19.99	19.99	20.01	20.00	20.00
25.00	25.00	25.02	25.02	24.99	24.99	19.99	24.99	25.00	25.00	25.00	25.00	24.99	25.00	25.00	25.00
30.00	30.00			30.00			29.99	30.00	30.00	30.00	29.99	29.99	30.00	30.00	30.00
50.00	50.02			50.01			49.99	50.00	50.01	50.01	49.99	50.00	50.00	50.01	50.00
75.00	75.00			75.01			75.01			75.01			75.01		
100.00	100.02			100.02			100.01			100.02			100.02		

Table 3-2b. Scale Calibrations and Precision Data - Reciprocating Chiller

NIST Standard Mass	Run 1			Run 2			Run 3			Run 4			Run 5		
	Pretest Calibration	Post-test Precision		Pretest Calibration	Post-test Precision		Pretest Calibration	Post-test Precision		Pretest Calibration	Post-test Precision		Pretest Calibration	Post-test Precision	
5.00	5.00			5.00			5.00			5.00			5.00		
10.00	10.00			10.00			10.00			10.00			10.00		
15.00	14.99			15.00			15.00			15.00			14.99		
20.00	19.99	19.99	20.00	20.01	19.99	20.00	20.00	20.00	20.00	20.00	19.99	19.99	19.99	19.99	19.99
25.00	24.99	25.00	25.01	25.00	25.00	25.00	25.00	25.00	25.00	24.99	24.98	24.99	24.99	25.00	24.99
30.00	29.99	30.00	29.99	30.00	30.00	30.00	30.00	30.00	30.00	30.00	29.99	29.99	29.99	29.99	29.99
50.00	50.00	50.00	50.00	50.00	50.00	50.00	50.00	50.00	50.00	49.99	49.99	50.00	50.00	49.99	49.99
75.00	75.00			75.00			75.00			75.00			75.00		
100.00	100.00			100.00			100.01			100.01			100.00		

Full charge and refrigerant withdrawal measurement errors were determined by computing an average difference between pre-test and post-test calibration results at the weights observed during testing:

$$\text{Error (lb)} = \text{Average [Pre-Test Difference \& Post-Test Difference]} \quad (\text{Eqn. 2})$$

Where: Pre-Test Difference = (Scale Reading – NIST weight), lb
 Post-Test Difference = average difference of precision results, lb

For example, the initial weight of the test cylinder for Run 4 on the chiller was 30.26 lb, and the final weight was 31.43 lb (i.e., the point at which the SGM alarmed). Both readings are representative of the 30 lb (nominal) NIST weight. Based on the pre- and post-test calibration results with this standard weight (Table 3-2b), the measurement error is computed to be -0.01 lb, per equation 2 above. When this error is accounted for, the actual initial weight is 30.26645 lb and the actual final weight is 31.43645 lb. The net difference between the initial and final weights remains unchanged, and thus, the error in refrigerant withdrawal is 0.00 lb. For both units, the initial and final weights were representative of a single NIST weight, and consistent with the example shown above, the overall error in the refrigerant withdrawal measurements is 0.00 lb for all test runs. The same approach was used to compute errors in full charge measurements. For both units, the initial full charge weighing was compared with the 75 lb NIST weight, and the final full charge weighing was compared with the 30 lb NIST weight. The largest error in full charge measurement was 0.02 lb. Table 3-3 summarizes the results of refrigerant withdrawal and full charge measurement errors for all the runs.

Using the measurement errors in full charge and refrigerant withdrawals, leak detection sensitivity errors for each Run were computed. As shown in Table 3-3, the maximum error in leak detection sensitivity was 0.14 percent for Run 3 at the chiller. Note that errors are shown to two decimal places in the table for simplicity. Since all the errors are less than the ± 2 percent specified in the Test Plan, the leak detection sensitivity DQO was met for all runs.

Table 3-3. Summary of Measurement and Leak Detection Sensitivity Errors							
Run	Full Charge Measurements		Refrigerant Withdrawal Measurements		Leak Detection Sensitivity		DQO Achieved?
	Measured Weight (lb)	Error ^{a,b} (lb)	Measured Weight (lb)	Error ^{a,b} (lb)	(%)	Error (% of leak detection sensitivity)	
Rooftop HVAC Unit							
1	51.74	0.00	3.43	0.00	6.63	- 0.01	Y
2	49.72	0.00	1.86	0.00	3.74	- 0.03	Y
3	52.35	+ 0.01	2.42	0.00	4.62	- 0.08	Y
4	52.35	+ 0.01	2.78	0.00	5.31	- 0.02	Y
5	52.37	- 0.02	2.70	0.00	5.16	+ 0.17	Y
Reciprocating Chiller							
1	47.10	0.00	2.13	0.00	4.52	- 0.06	Y
2	47.12	0.00	2.10	0.00	4.46	+ 0.07	Y
3	46.25	0.00	1.27	0.00	2.75	+ 0.14	Y
4	46.25	0.00	1.17	0.00	2.53	0.00	Y
5	46.68	0.00	1.65	0.00	3.53	- 0.14	Y
^a As compared to actual NIST-traceable standard masses that are representative of range observed during testing ^b For simplicity, errors are shown to two decimal places							

3.1.2 Data Completeness DQO Reconciliation

The Test Plan discussed the expected run-to-run variability in the test results. It is reasonable to expect that 90 percent of the observed leak detection sensitivities will fall within 0.30 times the mean. Test personnel used this range, or confidence interval (abbreviated *e* below), to determine the number of tests to conduct on each unit. The Test Plan specified a completeness DQO as follows: “Test runs must be repeated until 90 percent of observed values are within 0.30 times the mean leak detection sensitivity or a maximum of five valid test runs are executed.”

The GHG Center conducted five test runs at each unit. The confidence interval depends on the sample standard deviation and the number of test runs conducted as follows:

$$e = t_{0.05,n-1} \left(\frac{s}{\sqrt{n}} \right) \tag{Eqn. 3}$$

Where:

e = 0.30 times the mean of all test runs

$t_{0.05,n-1}$ = 90 % T distribution value (= 2.132 for five test runs)

s = sample standard deviation

n = number of sample runs (5)

Tables 3-4a and 3-4b present the individual test run results, the mean, standard deviation, and confidence interval for each unit. At both locations, the 90 percent confidence interval is within 0.30 times the mean leak detection sensitivity, and therefore the completeness goal was achieved.

Table 3-4a. Rooftop HVAC Data Completeness Goals			
Run	Leak Detection Sensitivity, %	Mean Leak Detection Sensitivity and 90 % Confidence Interval	Required 90 % Confidence Interval
1	6.63	5.09 ± 1.01 %	± 1.53 %
2	3.74		
3	4.62		
4	5.31		
5	5.16		
Sample Standard Deviation	1.057		Completeness DQO Achieved?
			yes

Table 3-4b. Chiller Data Completeness Goals			
Run	Leak Detection Sensitivity, %	Mean Leak Detection Sensitivity and 90 % Confidence Interval	Required 90 % Confidence Interval
1	4.52	3.56 ± 0.88 %	± 1.07 %
2	4.46		
3	2.75		
4	2.53		
5	3.53		
Sample Standard Deviation	0.929		Completeness DQO Achieved? yes

3.2 QA/QC CHECKS FOR NON-CRITICAL MEASUREMENTS

The GHG Center Field Team performed QA/QC checks on additional instruments during the test campaign. Data from these instruments did not directly contribute to leak detection sensitivity determinations, but they allowed test personnel to verify that the test units were operating normally and within expected parameters. Table 3-4 summarizes the results of these QA/QC checks.

Table 3-5. Summary of QA/QC Checks					
Measurement Variable	QA/QC Check	When Performed/Frequency	Expected or Allowable Result	Result Acceptable?	Response to Check Failure or Out-of-Control Condition
Gauge Manifold	Electronic leak check	Beginning of test on each system	System should be leak tight and purged of air	yes	Practice proper hose purging procedures; repair leaks as found
	Manifold and hose positioning	During testing	Hose and other accessories connected to the cylinders must be in identical position during each weighing	yes	Restore manifold and hoses to original position to prevent weighing errors
Ambient Temperature and Relative Humidity	Mfg. instrument calibration	Within 12 months prior to verification testing	Temp: ± 0.2 °F; RH ± 3%	yes	Repair/replace defective sensor or instrument; recheck performance
	One-point temperature check	Once per test day	± 2 °F when compared with colocated thermocouple		
	Relative humidity comparisons	Twice per test day	± 15 % RH when compared with Raleigh-Durham International Airport (RDU) data		
Refrigerant Line Temperature Sensors	Mfg. instrument calibration	Prior to verification testing	Temp ± 0.2 °F	yes	Repair/replace defective sensor or instrument; recheck performance

All QA/QC checks on non-critical instruments indicated that they performed properly throughout the verification tests.

3.3 POTENTIAL REFRIGERANT COST SAVINGS

As indicated in the Test Plan, quantification of the accuracy and precision of potential refrigerant cost savings is impossible because of the unknown quality of the available historical data. It was possible to obtain handwritten logbook entries for the two units tested. Copies of these entries reside in the GHG Center files. Section 2.4 discusses some of the interpretation limitations imposed by the unknowns in the data.

4.0 TECHNICAL AND PERFORMANCE DATA SUPPLIED BY KMC CONTROLS, INC.

NOTE: This section provides an opportunity for KMC Controls, Inc. to provide additional comments concerning the SGM and its features not addressed elsewhere in this Verification Report. The GHG Center has not independently verified the statements made in this section.

KMC Controls, Inc. (KMC), in order to accomplish laboratory quality tests in a field environment, used the following procedure to test this newly patented technology to conform to the requirements of the Greenhouse Gas Technology Center (GHG Center) and Southern Research Institute (SRI). These tests were performed for the U. S. EPA ETV program to provide quantifiable and repeatable test results for this new technology. They were conducted for the purpose of viewing the functional and leakage related activities of refrigerant through a Sight Glass Monitor on HVAC and other refrigeration equipment.

- In order to meet the test requirements, certain criteria were determined to be necessary to conform to the test parameters. The charging procedures were governed by environmental conditions and, as such, the KMC/Manufacturer's charging method is identified in the body of the report. It is also defined in the Test and Quality Assurance Plan on Page B-5 [under the heading Procedures for Charging the System] for the purpose of establishing a baseline methodology used during these tests (SRI 2001).
- For the purposes of the test, the variables as encountered under the constraints of this testing procedure may be different than those experienced under normal operating conditions. This could deviate from some published or standard practices. KMC recommends all HVAC systems be operated in compliance with Manufacturer's specifications and all industry and EPA guidelines.

In Addition, KMC would also like to acknowledge additional capabilities of the SLE-1001 that are not specifically part of this testing and verification process.

- Utilizing a separate set of infrared detection electronics the KMC SGM has the ability to monitor the moisture levels in the system. Elevated moisture levels can cause significant and catastrophic damage or failure of a refrigeration system.
- The SGM has the ability when connected to a KMDigital system to provide continuous monitoring and alarming features. When fully implemented, the SGM can create positive results in operating efficiencies.

Following is the KMC SLE-1001 Sight Glass Monitor Specification Data Sheet, which contains a functional description as well as guidelines and instructions for installation, wiring, operation, and calibration.



SLE-1001 Sight Glass Monitor Installation-Calibration Sheet

DESCRIPTION

The SLE-1001 refrigeration sight glass monitor is designed to be used with the Sporlan Valve Company's See-All® Combination Moisture & Liquid Indicators or equivalent. The SLE-1001 monitors two conditions through the sight glass window: Moisture content via the green-to-yellow colored indicator element, and flash gas (bubbles of non-condensed refrigerant). LED indication is provided on the front face of the SLE-1001 for visual indication of both observed conditions, and proportional 0 to 5 VDC outputs are provided for each monitored condition to interface with a KMDigital Facilities Management System, or approved equal.

The yellow LED on the front face of the SLE-1001 provides visual indication of the moisture content as observed through the sight glass. The yellow LED will glow brighter as the colored indicator element in the sight glass changes from green to yellow indicating higher moisture content.

The red LED on the front face provides visual indication of the refrigeration system's non-condensed refrigerant as observed through the sight glass. The refrigeration system's efficiency diminishes with the loss of system refrigerant. The presence of flash gas (bubbles of non-condensed refrigerant) in the refrigeration system can indicate an inefficient refrigeration system. The red LED will begin to pulse when flash gas is observed and will pulse faster as the amount of non-condensed bubbles increases.

Using the SLE-1001 with a KMDigital Controller to monitor and log the conditions observed through the sight glass, the KMDigital Facilities Management System can initiate alarms to alert personnel when moisture or flash gas is detected in a refrigeration system. This detection and reporting method ultimately saves energy and reduces ownership costs of refrigeration systems. Additionally, flash gas can be an indication of refrigerant loss. The SLE-1001's method of detection can be very useful as a supplemental technology for ANSI/ASHRAE Standard 15-1994.

SPECIFICATIONS

Power Supply:	24 VAC, +20/-15%, 50/60 Hz @ 1.5 volt amperes (VA)
Outputs:	0-5 VDC Flash Gas (bubble) detection, 100 K ohm minimum load impedance 0-5 VDC Moisture detection, 100 K ohm minimum load impedance (Both outputs are KMDigital input compatible with pull-up resistor removed)
LED Indication	
Flash:	Flash Gas detection (pulses red more frequently with greater concentration of bubbles)
Moisture:	Moisture detection (glows yellow in proportion to the degree of the yellow in the moisture indicator)
Cable:	10 ft, 4-Conductor, 22 AWG Black - 24 VAC Phase

White - Ground
Red - Flash Gas
Green - Moisture

Housing: Water and dust resistant, black flame retardant polymer, UL 94-5V rated

Dimensions: 3" x 2.5" x 1.5" (7.62 cm x 6.53 cm x 3.81 cm)

Ambient Limits

Operating: 32°F to 140°F (0°C to 60°C)

Shipping: -40°F to 140°F (-40°C to 60°C)

INSTALLATION

The SLE-1001 will fit snugly on a new or existing Sporlan Valve Company's See-All® Combination Moisture & Liquid Indicator. Due to the mating on the sight glass window frame, only sight glasses that have 0.25 in. clearance or more around the sight glass window frame can be used.

Existing Sight Glass Installation: The existing sight glass must be installed with the same requirements as for a new installation. The sight glass must be bright and clear. The window must be clear and the inside should not be dark or discolored. Some sight glasses can be reconditioned, while others may require replacement.

New Sight Glass Installation: Install the sight glass and the SLE-1001 Sight Glass Monitor in a vertical position with the flow of refrigerant upwards through the sight glass. If there is a pump-down solenoid in the refrigerant system, install the sight glass upstream of the pump-down solenoid and downstream of the drier. If the main reason for using the sight glass monitor is to increase the efficiency of the refrigerant system, then in addition to the previous instructions, install the sight glass as close to the expansion valve as possible. Care must be taken not to overheat the sight glass when soldering or brazing so that the sight glass' interior body will not become discolored. Follow the sight glass manufacturer's installation instructions for the proper installation of the sight glass.

SLE-1001 Installation: Remove the protective cap on the sight glass. The SLE-1001 fits the 1.34 in. diameter sight glass window frame, and comes with an adapter ring for the smaller 1.13 in. diameter sight glass window frame. Position the SLE-1001 over the sight glass window frame, using the adapter ring if necessary. Make certain the directional arrow on the SLE-1001 label is going with the flow of the refrigerant. The SLE-1001 mating surface must fit flush to the sight glass window. The SLE-1001 has a set of stainless steel mounting extension springs attached to one side and a set of mounting hooks on the other side. Take the two stainless steel mounting extension springs and pull one spring around the inlet pipe, the other spring around the outlet pipe, and connect the loop end of each spring to a mounting hook. The SLE-1001 should now be firmly mounted to the sight glass.

SLE-1001 Wiring: There are four wires to connect. The Black-wire connects to the phase of a 24 VAC transformer and the White-wire connects to the ground of the transformer. The SLE-1001 has a half-wave power supply, if the controller being used to monitor has a full-wave power supply, then a separate transformer must be used for the SLE-1001. If a separate transformer is used, then the White-wire must also connect to the controller's input ground. The Red-wire connects to the controller input that will be monitoring the Flash Gas (bubbles). The Green-wire connects to the controller input that will be

monitoring the moisture. If the controller being used is a KMDigital controller, remember to remove the "pull-up resistor" from the input circuits.

OPERATION

Leak Detection: When the refrigerant system is properly charged, any flash gas detection (non-condensed gas/bubbles) could indicate a refrigerant leak and low head pressure. The Flash LED will pulse red more frequently the more bubbles that are detected, and the voltage output will increase proportionally the more bubbles that are detected. KMC recommends charging per equipment manufacturer's recommendations and until the sight glass is clear of bubbles.

Moisture Detection: When the sight glass colored indicator element changes from green to yellow, indicating moisture in the system, the Moisture LED will begin to glow yellow and will glow brighter in proportion to the degree of yellow of the sight glass element, and the voltage output will increase proportionally to the degree of yellow of the sight glass element.

CALIBRATION

There is no field calibration of the SLE-1001 required. Periodic inspection of the sight glass should be performed. The sight glass must be bright and clear. The window must be clear and the inside should not be dark or discolored. Some sight glasses can be reconditioned, while others may require replacement.

5.0 REFERENCES

Air-Conditioning and Refrigeration Institute, *Refrigeration and Air-Conditioning, Second Edition*, Prentice Hall, Upper Saddle River, NJ. 1987.

ANSI/ASHRAE Standard 15. *Safety Code for Mechanical Refrigeration Units*. ANSI/ASHRAE 15. American National Standards Institute/American Society of Heating, Refrigeration, and Air-Conditioning Engineers, Atlanta, GA. 1994.

Carrier. *Installation, Start-Up and Service Instructions, 48DJ, DK, NP034-074, 50DJ, DK, DY, NB, NP034-074 Single Package Heating and Cooling Units*. Carrier Corporation, Syracuse, NY. 1996.

Code of Federal Regulations, 40 CFR Part 82, *Protection of Stratospheric Ozone; Refrigerant Recycling*, Vol. 58 No. 92 Friday, May 14, 1993.

Energy Information Administration, *Emissions of Greenhouse Gases in the United States 1996*, DOE/EIA-0573(96), U.S. Department of Energy, Energy Information Administration, Washington, DC. October 1997.

Energy Information Administration, *Emissions of Greenhouse Gases in the United States 1999*, www.eia.doe.gov/oiaf/1605/ggrpt, DOE/EIA-0573(99), U.S. Department of Energy, Energy Information Administration, Washington, DC. 1999.

Federal Register, 63 FR 32044, *Protection of Stratospheric Ozone; Refrigerant Recycling; Substitute Refrigerants; Proposed Rule*. June 11, 1998.

Federal Register, 60 FR 40420, *Protection of Stratospheric Ozone; Supplemental Rule to Amend Leak Repair Provisions Under Section 608 of the Clean Air Act; Final Rule*. August 8, 1995.

Moravek, Joseph, *Air-conditioning Systems, Principles, Equipment, and Service*, Air-conditioning and Refrigeration Institute, Prentice Hall, Upper Saddle River, NJ. 2001.

SRI. *Test and Quality Assurance Plan for the KMC Controls, Inc. SLE-1001 Sight Glass Monitor*. Southern Research Institute, Research Triangle Park, NC. 2001.

Thermal Engineering Company data sheet, *How Long Should You Evacuate A System*, Toledo, OH.