

US EPA ARCHIVE DOCUMENT



US Army Corps
of Engineers®

Field Pilot Study of In Situ Capping of Palos Verdes Shelf Contaminated Sediments

Thomas J. Fredette, James E. Clausner, Michael R. Palermo, Steven M. Bratos, Terry L. Prickett, Billy H. Johnson, Mamie S. Brouwer, Joseph A. Ryan, Lawrence J. Smith, Eleanor E. Nevarez, Fredrick K. Schauffler, and Scott McDowell

September 2002

Palos Verdes Shelf

Partnering Charter

We, the members of the Palos Verdes Shelf Pilot Capping Project, agree to work together in a spirit of pride, enjoyment, fiscal responsibility, respect for the environment, and cooperation to demonstrate the constructability of an *in-situ* cap on the Palos Verdes Shelf. We are committed to the following Partnering Objectives:

- Quality:** Conduct cap construction and monitoring operations to produce needed data of known and sufficient quality; evaluate constructability using the combined strengths of innovative predictive tools and data collection instruments.
- Safety:** Complete the project safely; with zero lost-time accidents; hold weekly safety meetings; instill good safety attitudes; maintain a safe working environment.
- Environmental Awareness:** Comply with all relevant Federal and State requirements; minimize potential detrimental impacts from the transport and placement of cap material; assess potential environmental impacts of cap placement operations.
- Schedule:** Begin the program in mid-July, and continue it in such a manner that avoids adverse effects to time or cost for any stakeholder.
- Port Construction:** Minimize any delay of final project completion for the Port of Long Beach Main Channel Deepening.
- Budget:** Complete the project within the established budget for the contractor and the Corps; ensure reasonable cost to the government and a fair profit to the contractor; keep all team members informed of potential budget changes; eliminate non-value-added costs and expedite progress when practical.
- Communication:** Maximize open and honest communications between all partners at all times through a protocol using the prescribed weekly communications plan; recognize the sense of urgency to be maintained in all project communications; exchanges of information and responses between any partnering team members will utilize appropriate communications methods.
- Problem-Solving/Issue Resolutions:** Resolve issues at lowest possible level; maintain respect and professionalism; expedite resolution of issues by escalation according to the issue resolution matrix; record and track any issues which remain unresolved for more than one week; issues listed on the status tracking form will be discussed at weekly meeting.
- Teamwork:** Treat team members with dignity and respect; be concerned for the success of all team members; understand and commit to mutual goals; and maintain a vision of both the Palos Verdes Pilot Capping Project and Queen's Gate Navigation Project; have fun and celebrate success.



Handwritten signatures of project team members, organized in three columns.



US Army Corps of Engineers.



Field Pilot Study of In Situ Capping of Palos Verdes Shelf Contaminated Sediments

by Thomas J. Fredette

U.S. Army Engineer District,
New England
696 Virginia Road
Concord, MA 01742-2751

James E. Clausner, Steven M. Bratos,
Terry L. Prickett

Coastal and Hydraulics Laboratory
U.S. Army Engineer Research
and Development Center
3909 Halls Ferry Road
Vicksburg, MS 39180-6199

Michael R. Palermo

Environmental Laboratory
U.S. Army Engineer Research
and Development Center
3909 Halls Ferry Road
Vicksburg, MS 39180-6199

Billy H. Johnson

Computational Hydraulics and
Transport, LLC
300 Front Street
Edwards, MS 39066

Mamie S. Brouwer

U.S. Army Engineer District, Seattle
P.O. Box 3755
Seattle, WA 98124-3755

Joseph A. Ryan, Lawrence J. Smith,
and Eleanor E. Nevarez

U.S. Army Engineer District,
Los Angeles
911 Wilshire Blvd.
Los Angeles, CA 90017

Fredrick K. Schaufler

Region 9, U.S. Environmental
Protection Agency
Superfund Division (SFD-7-1)
75 Hawthorn Street
San Francisco, CA 94105

Scott McDowell

Science Applications International
Corporation
Admiral's Gate
221 Third Street
Newport, RI 02840

Final report

Approved for public release; distribution is unlimited

Prepared for U.S. Environmental Protection Agency
1200 Pennsylvania Avenue, NW
Washington, DC 20460

Table of Contents

Prefacev
 Summary vii
 List of Acronyms..... xi
 Chapter 1: Introduction 1-1
 Chapter 2: Cap Placement Operations..... 2-1
 Chapter 3: Monitoring Activities and Results 3-1
 Chapter 4: Cap Placement Modeling..... 4-1
 Chapter 5: Discussion and Application of Results 5-1
 Chapter 6: References 6-1
 SF 298

Appendices¹

- A - Operations and Monitoring Plan (OMP)
- B - Monitoring Scopes of Work (SOW)
- C - Data Quality Objectives and Data Usability Assessment Process
- D - Project Work Plans (PWP) (Baseline, Summer 2000 Program, and Fall 2001 Addendum)
- E - Environmental Coordination Documents
 - E1 - Supplemental Environmental Assessment for Use of Queen’s Gate Material
 - E2 - Environmental Assessment for Use of A-III Borrow Site Material
 - E3 - Environmental Information Document Prepared for Coordination with California Coastal Commission

¹ Appendices A-L will be posted separately from the main text and will be linked as activated.

- E4 - Essential Fish Habitat Assessment for Coordination with National Marine Fisheries Service for Compliance with Magnuson-Stevens Fishery Management and Conservation Act
- F - Cap Material Characterization Reports
 - F1 - Queen's Gate Geotechnical Data
 - F2 - A-III Borrow Site Geotechnical Data
- G - Cap Placement Operations Data
- H - Cruise Report
- I - Baseline Monitoring Results from Field Pilot Study of In Situ Capping of Palos Verdes Shelf Contaminated Sediments
- J - Monitoring Results from Field Pilot Study of In Situ Capping of Palos Verdes Shelf Contaminated Sediments
- K - Modeling Results for Cap Placement, Plume, and Surge
- L - Monitoring Data from Field Pilot Study of In Situ Capping of Palos Verdes Shelf Contaminated Sediments (CD version of web site)

Preface

This report describes the results of a field pilot study of in situ capping on the Palos Verdes Shelf. The study was conducted by the U.S. Army Corps of Engineers (USACE) for the Region 9 office of the U.S. Environmental Protection Agency (EPA) as part of the ongoing Superfund investigation at the Palos Verdes (PV) Shelf. The results of this study will be used by EPA in deciding whether to propose remediation of the contaminated sediments at the PV Shelf by in situ capping. The study was conducted for EPA under Interagency Agreement (IAG) No. DW96955441-01. Ms. Ellie Nevarez, U.S. Army Engineer District, Los Angeles, was the study manager. Mr. Frederick Schauffler was the regional project manager (RPM) for this study.

The pilot study team included engineers, scientists, and technical support personnel from Region 9 of the USEPA, the Los Angeles District, the U.S. Army Engineer Research and Development Center (ERDC) Coastal and Hydraulics (CHL) and Environmental Laboratories (EL) at the Waterways Experiment Station (WES), the U.S. Army Engineer Districts Seattle and New England, Science Applications International Corporation (SAIC), and North American Trailing Co. (NATCO) Limited Partnership. Under the direction of the Los Angeles District, this team planned, designed, and implemented the pilot capping project.

NATCO was responsible for dredging, transporting, and placing the cap sediment at the PV Shelf. SAIC was responsible for executing the monitoring program under the direction of the USACE. The ERDC team was the technical lead for capping operations, numerical modeling, and water column acoustic monitoring. The Seattle District was the technical lead for data quality objective planning, sampling and analysis design, and data quality and usability assessment. The New England District was the technical lead for capping project management and monitoring program design and implementation.

This report was prepared by Dr. Thomas J. Fredette, New England District; Mr. James E. Clausner, Dr. Michael R. Palermo, Mr. Steve Bratos, Dr. Billy Johnson, and Ms. Terry Prickett, all of ERDC; Mr. Joe Ryan, Mr. Larry Smith, and Ms. Ellie Nevarez, all of the Los Angeles District; Ms. Mamie S. Brouwer, Seattle District, Mr. Fred Schauffler of EPA Region 9, and project scientists at SAIC.

At the time of publication of this report, Dr. James R. Houston was Director of ERDC, and COL John W. Morris III, EN, was Commander and Executive Director.

This report should be cited as:

Fredette, T., Clausner, J., McDowell, S., Palermo, M., Ryan, J., Smith, L., Bratos, S., Brouwer, M., Prickett, T., Nevarez, E., and Schaffler, F. (2002). "Field pilot study of in situ capping of Palos Verdes Shelf contaminated sediments," ERDC TR-02-5, U.S. Army Engineer Research and Development Center, Vicksburg, MS.

The contents of this report are not to be used for advertising, publication, or promotional purposes. Citation of trade names does not constitute an official endorsement or approval of the use of such commercial products.

Summary

The U.S. Environmental Protection Agency (EPA) Region 9 is continuing its investigation regarding the feasibility of in situ capping dichlorodiphenyltrichloroethane (DDT) and polychlorinated biphenyl (PCB) contaminated sediments on the Palos Verdes (PV) Shelf off the coast of Los Angeles, CA. As part of its technical support for the continued evaluation of in situ capping, the U.S. Army Corps of Engineers (USACE) performed a field pilot study of cap placement at the site. The overall objective of the field pilot study was to demonstrate that a cap can be placed on the shelf as intended by the design and to obtain field data on the short-term processes and behavior of the cap as placed.

Operations. Field operations and initial monitoring were conducted during the summer of 2000 with follow-up efforts during the winter of 2001. Over 103,000 cu m (135,000 cu yd) of capping material was placed within four 18-ha (45-acre) cells on the PV Shelf. Field monitoring and modeling of the pilot activities were conducted using a variety of instruments and methods.

Dredged sediments from the Port of Long Beach (POLB) Queen's Gate entrance channel and a sand borrow site were identified as the cap material sources for the pilot. The North American Trailing Co. (NATCO) hopper dredge *Sugar Island* was used for the pilot placements. Dredging and cap placement operations for the pilot project were coordinated with the monitoring efforts. Single hopper loads were initially placed and monitored. Then, multiple hopper loads were placed to build up the desired cap thickness, and monitoring was conducted as the cap was constructed. Queen's Gate material was placed using conventional point placements, and borrow site sand was placed using spreading methods. In addition, a single load was placed by pumpout through the hopper drag arm.

Monitoring. An extensive field monitoring effort was conducted as a part of the pilot. Major monitoring aspects for the pilot included cap thickness as placed, mixing of cap and contaminated sediments, resuspension of contaminated sediments during cap placement, bottom surge processes during capping events, and short-term physical and chemical characteristics of the cap and underlying sediments immediately after capping and following initial sediment consolidation.

A number of monitoring technologies were used including the following:

- **sediment profile and plan view images** (photographs) provided data on cap thickness, disruption of the existing contaminated sediment, and the presence of sediment-dwelling organisms (e.g., worms and other burrowing organisms) before and after capping;
- **sediment cores** provided data on cap thickness, sediment contaminant profiles and the degree to which contaminated sediments mixed with clean cap material during construction, and the stability of the cap after construction;
- **water samples and water column measurements** determined whether contaminated sediment was resuspended during cap construction (and if so, how far and in what direction it traveled before resettling to the bottom) and assessed the magnitude and extent of the suspended sediment plume created by cap placement;
- **current meters and optical backscatter sensors** defined both the magnitude and lateral extent of the surge created when the descending cap material reached the bottom, as well as the variation in current speed and direction in the water column overlying the placement cells;
- **side-scan sonar and sub-bottom acoustic profiling** assessed the lateral extent and thickness of the cap;
- **sediment samples from the hopper dredge** were used in modeling cap placement and to assess the efficacy of placement methods; and
- **dredge position and load curves** documented where each load of cap material came from and where it was placed.

Modeling. Mathematical models were used to predict the rate of cap material buildup for specific sediment characteristics, various water depths over the shelf and various placement approaches. The models were used to predict cap material dispersion during placement and evaluate the velocities of bottom impact on spreading behavior, respectively. These predictions were initially based on a broad range of assumed properties for the cap material. Once specific cap material sources were selected, refined predictions using the specific site conditions and cap material properties were made. Results of the refined predictions were used to adjust the operational approach and monitoring efforts for the pilot.

Pilot Study Conclusions. A summary of the pilot study conclusions is as follows:

- The construction of a cap to substantially isolate the contaminated sediments on the PV Shelf from the marine environment is an achievable objective.

- Both conventional placement using Queen's Gate sediments and spreading methods using borrow area sand proved successful in constructing the desired cap thickness.
- The numerical modeling simulations compared well to field data. These included comparisons of the distribution of cap material on the seafloor, comparisons of bottom surge speeds as a function of distance from the placement location, and comparisons of the size, transport, and dilution of the suspended sediment plume resulting from each placement operation.
- Evidence from the sediment profile imaging, coring, and side-scan surveys support a conclusion that creating a uniform cap over the effluent affected (EA) sediments on the PV Shelf is possible. The caps that were created using both conventional and spreading placement generally varied in thickness by only a few centimeters.
- Sediment profile data indicated that physical disturbance to the EA sediment was limited to a few centimeters for initial placements of cap material, and disturbance was minimized during the pilot study by careful management (i.e., overlap) of successive cap placement points. In addition, the spreading placement approach resulted in even less disturbance to in-place sediments than conventional placement methods.
- Elevated suspended solids and contaminant concentrations in the water column following placement of a load of cap material showed a rapid return to background levels following each placement event. Plume tracking data indicated low potential for impacts to nearshore kelp beds.
- Contaminant (DDE) measurements in core samples indicate that a clean cap can be constructed. The process of cap placement resulted in a 3-4-cm layer of mixed cap and EA sediment. As cap thickness increased beyond this, mixing with the EA sediment became negligible such that the levels of contaminants in upper portions of the cap were near those in the cap material source area.
- No evidence of cap or EA sediment instability with respect to avalanching or mud flows was observed as a result of operations. Current surge monitoring results indicated that the energy from conventional point cap placement decayed with distance and time away from the point of release. Surge velocities from spreading placements were much lower than for the conventional placements. No large-scale deformations or changes in the seafloor around the cells and in particular downslope were observed.
- The pilot demonstrated that a cap can be adequately monitored. The monitoring equipment and techniques proved generally effective in obtaining the desired data, and were generally effective across the range of site conditions encountered during the field pilot study.

- The pilot study results provided data on the ability to construct a cap and the effects of site conditions, material type, and placement methods on cap construction. These data will prove useful to decision-makers regarding implementation of any future full-scale cap on the PV Shelf.

Results of the pilot study will be used by EPA in its decision on any further remedial actions at the site. If additional capping is called for, the results of the pilot will be applied in the design and implementation of any full-scale project.

List of Acronyms

ABAB	Acoustic backscatter above background (from underway ADCP)
ADCIRC	Advanced Circulation model
ADCP	Acoustic Doppler Current Profiler
ADISS	Automated Disposal Surveillance System
ADISSPlay	Automated Disposal Surveillance System (helmsman display)
ARESS	Automated Resuspension Surveillance System
BBADCP	Broad Band Acoustic Doppler Current Profiler
CAD	Contained aquatic disposal
CD	Compact disk
CDFATE	Continuous Discharge Fate
CESPL	U.S. Army Engineer District, Los Angeles
CLP	Contract Laboratory Program
cm	Centimeter
cm/sec	Centimeter per second
CTD	Conductivity-temperature-depth
cu m	Cubic meter
cu yd	Cubic yard
DAN-LA	Disposal Analysis Network - Los Angeles
D-CORMIX	Dredging Cornell Mixing Zone Expert System
DDD	1,1-dichloro-2,2-bis(p-chlorophenyl)ethane
DDE	1,1-dichloro-2,2-bis(p-chlorophenyl) 1,1-dichloroethylene
DDT	1,1,1-trichloro-2,2-bis(p-chlorophenyl)ethane
deg	Degree(s)
DGPS	Differential Global Positioning System
DOER	Dredging Operations and Environmental Research
DQIs	Data quality indicators
DQOs	Data quality objectives
DROP MIX	Dredging Operations Mixing Zone
DRP	Dredging Research Program
EA	Effluent-affected
EA	Environmental assessment
ECD	Electron capture detector
EFH	Essential fish habitat
EIS	Environmental impact statement
EqP	Equilibrium partitioning
ERDC	U.S. Army Engineer Research and Development Center
FONSI	Finding of no significant impact
FSP	Field sampling plan

ft	Feet or foot
ft ²	Square feet
FTU	Formazin turbidity units
GC	Gas chromatograph
GC/MS	Gas chromatography/mass spectrometry
GIS	Geographic Information System
g/cc	Grams per cubic centimeter
g/L	Grams per liter
GMT	Greenwich Mean Time
GPS	Global Positioning System
GSD	Grain size distribution
ha	Hectare
J	Estimated
km	Kilometer
km ²	Square kilometers
kts	Knots
LACSD	Los Angeles County Sanitation Districts
LAD	Los Angeles District
LC	Landward center
LCS	Laboratory control standard
LD	Landward downstream
LTFATE	Long Term Fate
m	Meter
m ³	Cubic meters
mm	Millimeter
m/s	Meters per second
m/year	Meter per year
MDFATE	Multiple Dump Fate of Dredged Material
MDL	Method detection limit
µg/kg	Microgram per kilogram
µg/L	Microgram per liter
mg/kg	Milligram per kilogram
mg/L	Milligram per liter
MQOs	Method quality objectives
MS/MSD	Matrix spike and matrix spike duplicates
NAD 83	North American Datum 1983
NATCO	North American Trailing Company
NEPA	National Environmental Policy Act
ng/L	Nanogram per liter
NMFS	National Marine Fisheries Service
NOAA	National Oceanographic and Atmospheric Administration
OBS/ADCP	Optical Backscatter Sensors/Acoustic Doppler Current Profiler
ODAMS	Open Water Disposal Area Management
OMP	Operations and Monitoring Plan
PCB	Polychlorinated biphenyl
POLB	Port of Long Beach
PV	Palos Verdes
PVC	Plan view camera
PWP	Project work plan
QA	Quality Assurance

QAO	Quality Assurance Office
QAPP	Quality Assurance Project Plan
QC	Quality Control
R	Rejected
ROD	Record of decision
RPD	Redox potential discontinuity
RPD	Relative percent differences
RRM	Regional Reference Material
RSD	Relative standard deviation
SAIC	Science Applications International Corporation
SAP	Sampling and analysis plan
SAV	Submerged aquatic vegetation
SCMI	Southern California Marine Institute
SD	Seaward downstream
SEA	Supplemental environmental assessment
SOP	Standard operating procedure
SOW	Scope of work
SPC	Sediment profile camera
SPI	Sediment-profile imaging
SPL	South Pacific Division, Los Angeles District
SSFATE	Suspended Sediment Fate
STFATE	Short Term Fate of Dredged Material
SU	Seaward upstream
TSS	Total suspended solids
U	Nondetected
UJ	Nondetected estimated
USACE	U.S. Army Corps of Engineers
USCG	U.S. Coast Guard
USCS	Unified Soil Classification System
USEPA	U.S. Environmental Protection Agency
USGS	U.S. Geological Survey

1 Introduction

1	Introduction.....	1-1
1.1	Background.....	1-1
1.2	Purpose and Scope.....	1-2
1.3	Site and Project Description.....	1-3
1.3.1	PV Shelf site.....	1-3
1.3.2	Cap material borrow areas.....	1-4
1.3.3	In situ capping options.....	1-4
1.4	Pilot Study Objectives and Approach.....	1-5
1.4.1	Cap placement operations.....	1-6
1.4.2	Monitoring.....	1-7
1.4.3	Modeling.....	1-7
1.5	Pilot Study Management and Documentation.....	1-7
1.5.1	Project team.....	1-7
1.5.2	Partnering arrangements.....	1-8
1.5.3	Data management.....	1-8

1.1 Background

Sediments at the Palos Verdes (PV) Shelf site off the coast of Los Angeles, CA, are contaminated with 1,1,1-trichloro-2,2-bis (p-chlorophenyl) ethane (DDT)¹ and polychlorinated biphenyl hydrocarbon (PCB). The U.S. Environmental Protection Agency (EPA) is continuing its non-time critical removal action engineering evaluation/cost analysis (EE/CA) regarding the feasibility of in situ capping all or a portion of these sediments. In situ capping is defined as the placement of a covering or cap of clean material over the in situ deposit of contaminated sediment.

In an earlier study, the U.S. Army Corps of Engineers (USACE) evaluated in situ capping options for EPA based on limited site-specific data and the USACE

¹ For purposes of this report, unless otherwise stated, DDT refers to total DDT as including DDT, 2,2-bis (p-chlorophenyl) 1,1-dichloroethylene (DDE), and all its isomers and metabolites and PCB refers to total PCB to include all PCB congeners. Chemical data for the pilot study were developed for DDE, because the p,p'-DDE isomer is the dominant DDT component in the sediments. Also, since distributions of sediment DDT and PCBs are similar, DDE was considered a good marker for both contaminants of concern.

experience with capping projects at other sites. The evaluation included prioritizing areas of the PV Shelf to be capped, determining appropriate cap designs, developing an equipment selection and operations plan to ensure successful placement of the cap, developing a monitoring plan to assess cap placement operations and long-term cap effectiveness, and developing preliminary cost estimates. The complete capping options study is published as U.S. Army Engineer Waterways Experiment Station (WES) report TR-EL-99-2 (Palermo et al. 1999) <<http://www.wes.army.mil/el/elpubs/pdf/trel99-2.pdf>>.

In September 1999, EPA entered into an interagency agreement (IAG) (No. DW96955441-01) with the U.S. Army Engineer District, Los Angeles, for continued technical support at the PV Shelf site. Under Task 3 of IAG, *Pre-Design Data Collection and Studies*, USACE was asked to (a) identify site data gaps and conduct field sampling and surveys; (b) conduct treatability/pilot studies and computer modeling to support design of the selected response action; (c) coordinate predesign data collection and studies with an EPA-established review team; and (d) develop the technical statement of work and award and manage contract(s) necessary for predesign studies. As part of its technical support for the continued evaluation of in situ capping, USACE performed a field pilot study of cap placement at the site.

The pilot study, which involved cap material dredging and transport, cap placement operations, and initial monitoring, was conducted between May 2000 and March 2001. Over 103,000 cu m of capping material was dredged from the Queen's Gate entrance channel to Long Beach Harbor and from a sand borrow area outside the harbor, and placed in several 300-m by 600-m capping cells on the PV Shelf. Field monitoring and modeling of the pilot study activities were conducted using a variety of instruments and methods.

1.2 Purpose and Scope

The purpose of this report is to describe and interpret the results of the field pilot study of in situ capping of PV Shelf contaminated sediment. Although monitoring continues at the site, this report only covers results of the initial monitoring effort through the summer of 2000 and follow-up efforts during February and March 2001.

The main body of this report provides a description of the pilot study approach and methodology, the dredging and placement operations associated with the pilot study, monitoring activities and results, modeling of cap placement, interpretation of the pilot study results, and recommendations with respect to long-term monitoring and possible full-scale capping at the site.

1.3 Site and Project Description

1.3.1 PV Shelf site

A description of the PV Shelf site and adjacent areas is summarized here from earlier reports¹ (Lee 1994; Palermo 1994; and Palermo et al. 1999). The major areas of interest are shown in Figure 1-1.

The PV Shelf site is located off the PV Peninsula, which separates Santa Monica and San Pedro Bays. The contaminated sediments at the site are found on both the continental shelf and slope, generally defined as the offshore area extending from Point Vicente southeast to Point Fermin. The Los Angeles County Sanitation District (LACSD) ocean outfall system discharges treated wastewater onto the shelf approximately 3 km offshore of Whites Point in approximately 60 m of water.

The continental shelf in this area varies in width from approximately 1 to 6 km and extends offshore to the shelf break at water depths of approximately 70 to 100 m, where the continental slope begins. The bottom slope on the shelf generally increases with water depth, with slopes of approximately 1 to 3 deg at water depths of 30 to 70 m. The bottom slope increases to approximately 6 to 7 deg at depths of 70 to 100 m. At the 100-m depth, the slope increases to 13 to 18 deg.

Compared with other coastal areas in southern California, the area off the PV Peninsula has a relatively mild wave climate, primarily due to the sheltering effects of the offshore islands, with Santa Catalina and San Clemente providing protection from waves approaching from the south. Waves are most severe in the winter (i.e., from December to March) and mildest in the summer and early fall (i.e., from July to October). Mean wave heights are 1.0 m, with significant waves heights greater than 1.0 m occurring only 45 percent of the time and wave heights greater than 1.5 m occurring only 18 percent of the time. Higher waves generally approach from the west to south.

During fair weather, surface currents range from 7 to 10 cm/sec, with maximum alongshelf currents of 40 cm/sec and cross-shelf currents of 20 cm/sec. Surface currents are most likely wind- and wave- dominated and are unlikely to be strong except during storms. Mean surface currents on the shelf are less than 5 cm/sec. Subsurface currents on the shelf are generally weak also. The exception is a potentially strong northwestward flowing current at depth along the base of the slope that can reach velocities of up to 60 cm/sec during storms (LACSD 1996).

The native sediments of the shelf are comprised of silty sand. Since the first outfall diffusers became operational in 1937, particulate matter discharged

¹ This description was shortened from that in Palermo et al. (1999). Details on ocean sewer outfalls, seismic events, and groundwater flow conditions were not included here.

through the outfalls has settled out and built up an effluent-affected (EA) sediment deposit on the shelf and slope. This EA deposit contains levels of organic matter and chemical contaminants higher than the native sediments and provides the focus of sediment restoration/ remediation efforts on the shelf and slope. The DDT and PCBs in this EA deposit originated from past industrial and commercial discharges to the LACSD sewer system.

The footprint of the EA deposit as defined by the U.S. Geological Survey (USGS) studies (Lee 1994) is shown in Figure 1-2. The EA deposit forms a band that extends from approximately the 30-m water depth offshore to water depths in excess of 400 m at a distance of approximately 3 to 7 km offshore, and alongshore from Point Fermin to an area northwest of Point Vicente, a distance of 12 to 15 km. The EA deposit is absent from approximately the 30-m water depth shoreward because the higher wave energy does not permit the finer contaminated particles to deposit. A plot of the DDT peak concentrations within the footprint is shown in Figure 1-2. The most contaminated sediments on the shelf occur as a lens approximately 10 to 30 cm below the sediment-water interface. A more detailed characterization of the shelf and slope has been prepared by Lee (1994).

1.3.2 Cap material borrow areas

Two sites were used for obtaining capping materials for the pilot study, the Queen's Gate entrance channel to Long Beach Harbor and a nearby sand borrow site (Borrow Area A-III) (see Figure 1-1). Both of these areas were identified by the USACE (Palermo et al. 1999) as potential cap material sources. A large breakwater structure encloses Los Angeles and Long Beach Harbors, with two main entrance channels providing access. Deepening of the Queen's Gate entrance channel was initiated in 1998, and the work was in progress during the time frame of planning for the pilot study project. Large areas outside the harbor breakwaters are potential sources of sand, and borrow site A-III was identified for purposes of the pilot study.

1.3.3 In situ capping options

Two capping approaches were considered in Palermo et al. (1999) for selected areas of the shelf: a) placement of a thin cap (i.e., design thickness of 15 cm), which would isolate the contaminated material from shallow burrowing benthic organisms, providing a reduction in both the surficial sediment concentration and contaminant flux, and b) placement of an isolation cap (i.e., design thickness of 45 cm), which would be of sufficient thickness to effectively isolate the majority of benthic organisms from the contaminated sediments, prevent bioaccumulation of contaminants, and effectively prevent contaminant flux for the long term. These design cap thicknesses were considered in setting target cap thicknesses for the pilot study.

The shelf area presently under consideration for capping lies between the 40- and 70-m depth contours (in Palermo et al. (1999), this area was defined as two

separate capping prisms: prism A centered over the hot spot, and prism B located northwest of the hot spot). If capping were selected as a remedy for the PV Shelf, the operations would be done in an incremental fashion until the total selected area was capped. Because the area that is being considered for capping is large (on the order of several square kilometers), capping placement cells of 300 m by 600 m were defined for purposes of modeling the placement of cap material, estimating volume requirements, designing a monitoring program, and developing cost estimates.¹

1.4 Pilot Study Objectives and Approach

The overall objective of the field study was to demonstrate constructability of a cap on the shelf and to obtain field data on the capping processes and impacts of cap construction. Specific objectives addressed as a part of the pilot study are as follows (Palermo 2000):

- a. Demonstrate that an appropriate cap thickness can be placed with an acceptable level of variability in cap thickness.
- b. Demonstrate that excessive resuspension of existing EA sediments and excessive mixing of cap and sediments can be avoided.
- c. Demonstrate that excessive losses of cap materials can be avoided.
- d. Determine, to the degree possible, the effects of variable cap material type, bottom slope, water depth, and placement method (e.g., conventional versus spreading) on cap thickness and EA sediment displacement and resuspension.
- e. Demonstrate the effectiveness of the cap with respect to short-term isolation of contaminants during initial sediment consolidation.
- f. Demonstrate the ability to monitor operations and success.
- g. Evaluate and modify, where needed, all operational and monitoring approaches.
- h. Demonstrate the ability of existing numerical models to accurately simulate cap placement.
- i. Improve the knowledge base contributing to decisions on implementation of a full-scale cap.

The pilot study addressed these objectives with an operational effort for cap material dredging and placement, modeling to guide the operations, and

¹ A grid of 56 capping placement cells was defined in Palermo et al. (1999) for purposes of volume and cost estimates for various capping options; however, these cell locations were not considered final for purposes of either the pilot or any full-scale capping operation.

monitoring to provide needed data. Each of these aspects of the pilot study is described in the following paragraphs and in detail in Chapters 2, 3, and 4.

The construction of the pilot study caps occurred over a time period of 7 weeks, and the associated monitoring effort was focused on short-term processes associated with cap construction, and processes occurring during and shortly after cap material placement.

A full-scale monitoring program to be conducted during any placement of a full-scale cap, and in the years to follow, would additionally include activities aimed at long-term processes that could not be easily observed during the time period available for the pilot study (e.g., erosion during storm events or migration of contaminants due to diffusive processes). The monitoring scope developed for the pilot study does not yet include long-term monitoring, although EPA anticipates adding that type of evaluation to the scope of the pilot study. Depending on the time scales in which the pilot study cap is in place prior to any full-scale cap placement, there may be an opportunity to obtain data from the pilot study area related to such long-term processes, but such activities are not addressed in this report on the pilot study.¹

1.4.1 Cap placement operations

The pilot study approach consisted of controlled operations for placement of capping material within selected areas on the PV Shelf and associated monitoring prior to, during, and following the placements. Preplacement operational aspects for the pilot study included the selection of appropriate placement areas for the pilot study, selection of appropriate sources for capping materials, and development of appropriate placement techniques. Cap placement operations were conducted using a hopper dredge to place material using three methods: a) releasing material in the conventional manner, by fully opening the hopper doors at predetermined discrete locations, which is also known as conventional placement, b) spreading material by partially opening the hopper doors during placement as the dredge sailed a linear track line, which is also known as spreading placement, and c) spreading by pumpout through one of the hopper drag arms. Cap placement operations are described in detail in Chapter 2.

¹ Palermo et al. (1999) provides the outline for a long-term monitoring effort. Such an effort would include coring, sediment profile camera surveys, and sub-bottom profiles. Several other items related to long-term cap performance monitoring not explicitly addressed in the pilot study plan would be addressed by a long-term plan. These include determination of the abundance of deep burrowers, reductions in water column contaminant concentrations, verification of the diffusion model, and reductions in tissue contaminant concentrations in resident benthic or fishery species. If EPA decides to proceed with a full-scale capping remedy, a detailed monitoring program to address long-term questions would be required.

1.4.2 Monitoring

An extensive field monitoring effort was conducted as a part of the pilot study. Monitoring aspects for the pilot study focused on cap thickness as placed, mixing of cap and contaminated sediments, resuspension of contaminated sediments during cap placement, and short-term physical and chemical characteristics of the cap and underlying sediments immediately after capping and following initial sediment consolidation. Single hopper loads were initially placed and monitored. Then, multiple hopper loads were placed to build up the desired cap thickness, and monitoring was conducted at several stages as the cap was constructed. State-of-the-art monitoring tools and methods were applied including sediment profile and plan view photographs, sediment cores, water samples and water column measurements, current meters and optical backscatter sensors, side-scan sonar and sub-bottom acoustic profiling, sediment samples from the hopper dredge, and dredge position and load measurements. Field monitoring activities and data are described in detail in Chapter 3.

1.4.3 Modeling

Predictive modeling for the pilot study was conducted to guide operations and monitoring efforts and to provide improved predictive capability for any subsequent full-scale capping efforts. The models were used to predict the rate of cap material buildup for specific sediment characteristics, various water depths over the shelf, and various placement approaches; cap material dispersion during placement; and velocities of bottom impact and spreading behavior. These predictions initially were based on a broad range of assumed properties for the cap material. Once specific cap material sources were selected, refined predictions using the specific site conditions and cap material properties were formed. Results of the refined predictions were used to adjust the operational approach and monitoring efforts for the pilot study. Following cap placement, additional after the fact, or hindcast simulations were conducted to compare model predictions using operational data and cap properties as determined from the monitoring results. Modeling activities and results are described in detail in Chapter 4.

1.5 Pilot Study Management and Documentation

The pilot study involved a complex combination of dredging and placement operations, field monitoring, modeling, and data management and interpretation. A well-organized effort was required to manage and document the project and insure that the objectives of the study were met within the required time frames.

1.5.1 Project team

The pilot study was planned, designed, and executed by the Los Angeles District with support from the U.S. Army Engineer Research and Development

Center (ERDC) Coastal and Hydraulics Laboratory (CHL) and ERDC Environmental Laboratory (EL), both located at the Waterways Experiment Station (WES); and the U.S. Army Engineer Districts New England and Seattle. Dredging operations for the pilot study were conducted by the North American Trailing Co. (NATCO) Limited Partnership, under contract with the Los Angeles District. Field monitoring activities were conducted by Science Applications International Corporation (SAIC), under contract to the Los Angeles District, with support from and oversight by all four USACE team members. The EPA prepared an environmental information document for the capping aspects of the pilot study and the sampling and analysis plan (SAP) for borrow site characterization. The EPA Region 9 Quality Assurance Office (QAO) evaluated and provided review comments for the pilot study project work plans, which included the field sampling plans (FSPs) and quality assurance project plans (QAPPs) prepared by the project team.

1.5.2 Partnering arrangements

A partnering session for the Palos Verdes (PV) Shelf pilot study was conducted on 30 and 31 May 2000 in San Pedro, CA. An official partnering agreement was entered into by the EPA, the Port of Long Beach (POLB), USACE, NATCO, SAIC, and the U.S. Coast Guard. This agreement is shown in the text box on the inside cover of this report.

1.5.3 Data management

The pilot capping study was planned according to Operations and Management Plans (see Appendix A), Monitoring Scopes of Work (see Appendix B), and the requirements of the EPA DQO planning process (see Appendix C). All pilot study capping project monitoring data were collected, analyzed, and evaluated according to the procedures, guidelines, and specifications described in the baseline, interim and post-capping PWPs prepared by SAIC (see Appendix D). The PWPs included a work plan and a sampling and analysis plan (SAP), which was composed of a field sampling plan (FSP) and quality assurance project plan (QAPP). These documents were prepared according to the EPA guidelines for project quality planning document preparation. The chemical analytical laboratory that analyzed the marine water and sediment samples and the field quality control (QC) samples (the Woods Hole Group, located in Massachusetts) was a USACE-validated facility. All data were validated according to the EPA Contract Laboratory Program (CLP) guidelines for validating data. The data validation report is located in Appendix B of the SAIC monitoring report (see Appendix I and J of this report). The usability of these data is assessed in Appendix A of this report. All processed data are located in the Geographical Information System (GIS) known as the Dredging Analysis Network-Los Angeles (DAN-LA) that was developed by SAIC for the pilot capping project.



Figure 1-1. Location map showing Palos Verdes Shelf and slope, showing EA sediment footprint, pilot capping cells, Queen's Gate entrance channel, and borrow site A-III

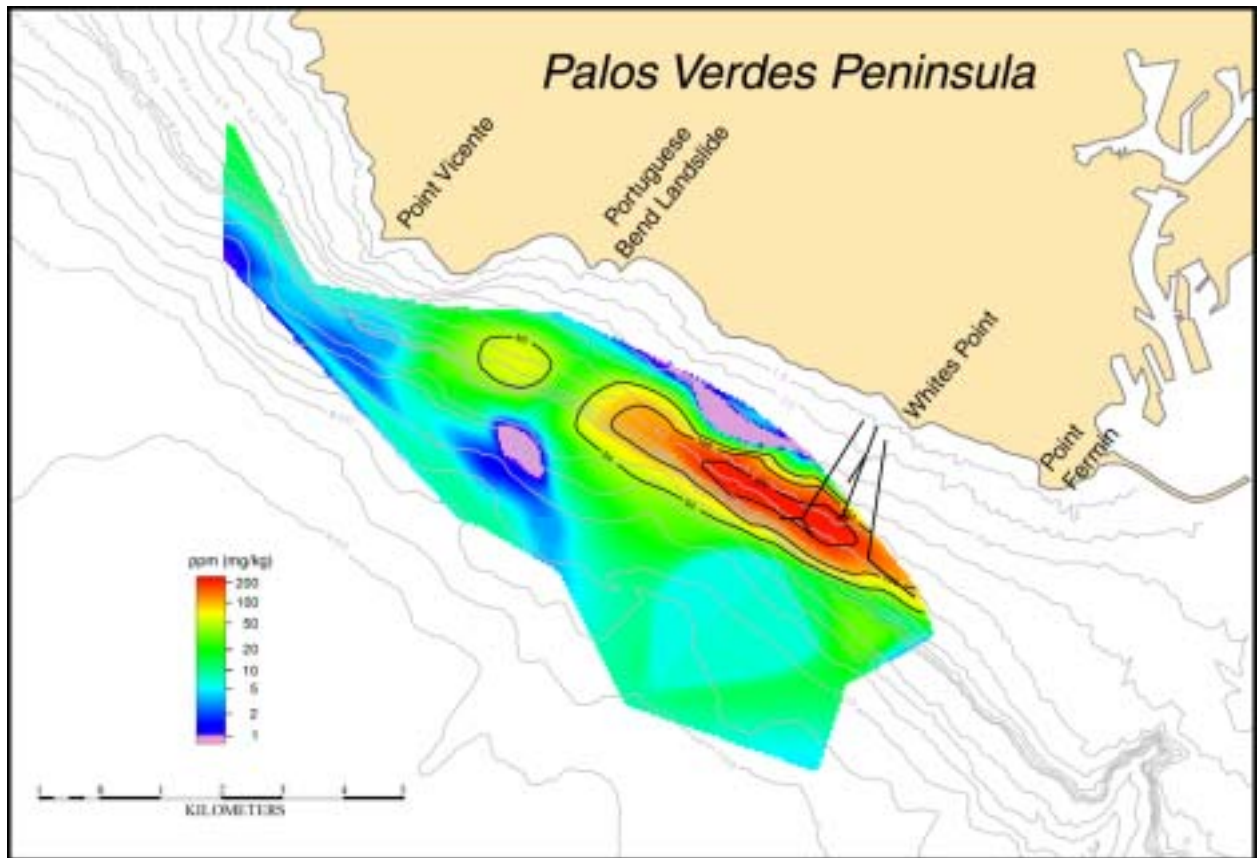

Figure 1-2. Map showing maximum sediment concentration of total DDT at any 4-cm depth increment (from Lee et al. 1994)

2 Cap Placement Operations

2	Cap Placement Operations	2-1
2.1	Operations Plan.....	2-1
2.1.1	Selection of pilot capping placement areas	2-1
2.1.2	Selection of cap material sources	2-4
2.1.3	Selection of placement equipment	2-6
2.1.4	Planned cap thicknesses and volumes	2-7
2.1.5	Plan for placement operations	2-8
2.2	Environmental Coordination.....	2-9
2.3	Dredging and Cap Placement Operations	2-11
2.3.1	Dredging methods	2-11
2.3.2	Cap placement methods.....	2-12
2.3.3	Placement sequencing	2-13

2.1 Operations Plan

An Operations and Monitoring Plan (OMP) was prepared to document the rationale and overall approach for the pilot study and facilitate planning (Palermo 2000). The OMP served to describe the needed placement operations for the pilot study cap and the short-term monitoring plan needed to meet the study objectives. The operations aspects of the pilot study are described in this chapter, while the monitoring aspects are described in Chapter 3. The OMP in its entirety is found at Appendix A.

2.1.1 Selection of pilot capping placement areas

The area of the Palos Verdes Shelf site considered for capping in Palermo et al. (1999) is on the order of several square kilometers. The range of site conditions varies, including water depth, bottom slope, and EA sediment properties. A rationale was therefore required to choose the best possible location(s) for the cap placement areas. Specific considerations for selection of the pilot study locations included:

- a. To the extent possible, placement locations for the pilot study should be representative of the overall range of conditions within the total anticipated capping area for a full-scale remediation.

- b. Different pilot study placement locations would be necessary to demonstrate the combined effects of water depth, bottom slope, cap material type, and placement method on cap thickness and sediment resuspension.
- c. Physical bottom material type in the pilot study placement areas should be clearly distinguishable from capping material. This requirement would be met by any location with surficial fine-grained EA sediment, since the capping material was anticipated to be composed of fine sandy sediment.
- d. The thickness of the EA sediment in the pilot study placement areas should be greater than the maximum depth of EA sediment resuspension that would be expected to occur during placement. The thickness must also be sufficient to measure the effects of advection due to consolidation. The mixing thickness requirement with respect to resuspension would be met with any location having surficial fine-grained EA sediment thickness in excess of 10 cm. The thicker the EA deposit, the easier the measurement of advection effects.
- e. The level of surficial EA sediment contamination (upper few centimeters) for the pilot study placement areas will affect whether water column measurements of contaminants (DDT and/or PCBs) can be used to evaluate resuspension and transport. Areas with higher ranges of surficial contamination (i.e., 10 to 20 mg/kg DDT) would provide conservative and more easily measurable data on resuspension and water column DDT concentrations.
- f. There are concerns related to placement of capping materials directly over or immediately adjacent to the LACSD outfall pipes. To avoid impacts to the outfall structures, cap placements were not located directly over or immediately adjacent to the LACSD outfall pipes.
- g. Recontamination of the pilot study cap during cap placement may complicate the interpretation of pilot study results, and if such recontamination occurs following placement (e.g., due to transport of contaminated sediments from uncapped areas upcurrent of the pilot study cap), the area may have to be capped a second time if EPA decides to proceed with a full-scale capping remedy. The potential for such recontamination will vary depending on pilot study cell locations (among other things). The prevailing bottom current is from southeast to northwest, so locations to the southeast are preferable from this standpoint.
- h. The southeastern boundary of the EA sediment footprint (see Figure 1-2) is based on the 1994 USGS box core data. LACSD data indicate that EA sediment extends well to the southeast of this boundary, although thickness and contaminant concentrations decrease as well. This area is not well characterized in terms of sediment core data. Additional data would be needed to further define the most appropriate boundary which should be considered for capping, including any decision to locate the pilot study capping cells in this area.

- i. The size of the pilot study capping area(s) should be sufficiently large to avoid interference between intentionally separate placements (using different placement methods and/or cap materials) and to allow for demonstrating the effect of multiple placements in building the desired cap thickness. Modeling results indicate the size of a footprint of measurable cap thickness accumulation resulting from a single conventional placement is about the size of a single 300 by 600-m capping cell.¹ Therefore, a buffer of approximately 300 to 600 m between capping cells was considered sufficient to avoid interference between intentionally separate placement events.

Based on these considerations, a layout of four 300 by 600-m capping placement cells was initially recommended for the pilot. One pair of cells in the layout was located adjacent to the landward limit of the capping area in a comparatively shallow site with comparatively flat bottom slope (40 m to 45-m depth contour with an average slope across the cell of about 1 deg). A second cell pair in the layout was located adjacent to the seaward limit in a deeper site with steeper bottom slope (60 to 70-m depth contour with average slope across the cell of about 3 deg). The two cells within each pair were separated by a full cell length in the alongshore direction and by a full cell width in the perpendicular direction to avoid the potential for interferences during monitoring.

No single area within the identified capping prisms is ideal with respect to all the considerations listed; therefore, two potential locales with differing conditions were identified and compared in selecting the pilot study cell locations. One locale evaluated for the placement cells is at the southeastern end of capping prism A (see Palermo et al. 1999), in the area roughly bounded by the 40 and 70-m depth contours and located between LACSD transects 9 and 10. This area is to the southeast of the terminus of the outfalls, on the upcurrent end of the capping area with respect to prevailing bottom currents. There is little USGS box core data for this area. However, available LACSD data indicate that EA sediment thickness in this area may exceed 10 cm (refer to Figure 60 in Lee et al. 1994), and the surficial DDE concentration is about 2 mg/kg (refer to Figure 5 in Lee et al. 1994). This locale has the advantage of upstream location with respect to residual bottom currents, but has the disadvantage of unknown EA sediment thickness and potentially low DDE concentration with respect to the overall area.

A second locale evaluated for pilot study placement is to the northwest of the outfalls. There is good USGS box core data coverage for this area. The EA sediment thickness in this area is in excess of 50 cm (refer to Figure 60 in Lee et al. 1994) and the surficial DDE concentration is 10 to 20 mg/kg (refer to Figure 5 in Lee et al. 1994). This locale has the disadvantage of being downstream of a significant portion of the site with respect to bottom currents, with a higher potential for surface recontamination. But the EA sediment thickness is greater, with easier interpretation of consolidation effects, and the surficial DDE is high, yielding better resolution potential for cores and

¹ Note that the designation and location of pilot cells for the pilot do not correspond to the cell grid layout described in Palermo et al (1999).

worst-case resuspension data. This locale is also downstream with respect to the outfalls, thus minimizing the possibility that capping will interfere with outfall operations.

In evaluating and comparing these two locales, the potential disadvantages of recontamination during placement for the northwest locale were deemed acceptable, and the northwest locale was therefore selected for the pilot study placements. The four cell locations originally recommended in this locale were named according to their relative geographic location: LU (Landward Upstream), LD (Landward Downstream), SU (Seaward Upstream), and SD (Seaward Downstream). The upstream cells were on the upstream side of the prevailing northwesterly, alongshore current, while the downstream cells were on the downstream side.

As the project planning and cost estimating for the pilot study evolved, it became apparent that the project scope would have to be decreased to stay within budget. Eliminating placement of capping material and the associated monitoring from the least critical cell would keep the project within budget. It was determined that Cell SD could be deleted from the pilot study without sacrificing significant information gathering. Therefore, the final pilot study went forward with the three cells, LU, LD and SU (see Figure 2-1). Pilot placements occurred within the limits of these three cells. The base line program was conducted for the originally selected four cells, and the total area monitored during the pilot study extended to adjacent cells. To accommodate a single hopper pumpout load, the 600-m by 300-m area situated between Cells LU and LD was utilized for the one-time pumpout and was named Cell LC (Landward Center).

2.1.2 Selection of cap material sources

The Los Angeles District (LAD) had earlier surveyed the region for potential cap material sources as a part of the capping options study and updated available information on borrow sources (see Palermo et al. 1999). During the planning phase, a number of possible borrow sources were identified. Dredged sediments from navigation channels (primarily the Queen's Gate deepening project) and sand borrow areas were identified as the two primary sources. The cap designs and placement approaches were developed based on those potential sources.

Cap material requirements included the following:

- a. The cap material used for the pilot study must be representative of the materials that would be available for a full-scale capping remedy.
- b. The source of cap material must allow for cost-effective dredging and placement.
- c. The material needed to be available during the time frame of the pilot study.

Use of dredged material from ongoing navigation projects would be far less expensive than excavation from borrow sites, since the operational cost attributable to the pilot study would be limited to the difference in transportation and placement cost on the PV Shelf as compared to the selected placement sites. However, use of dredged material from an ongoing project would be dependent on close coordination of navigation dredging schedules and contracts. Use of dredged material from an approved navigation project could also be advantageous for the overall schedule, since the dredging impacts in the channel areas and ocean placement of the sediments would have already been evaluated, thus making the National Environmental Policy Act (NEPA) process and other regulatory considerations for the pilot study more straightforward.

Evaluation of Queen's Gate channel sediments. The Port of Long Beach Queen's Gate entrance channel, which was being deepened to -23.2 m, was the only ongoing navigation project with sufficient volume of clean material to conduct the pilot study. Data available during the planning for the pilot study indicated that the material had an in situ mean grain size of approximately 0.1 mm. Prior to the final decision on cap material sources, additional sampling indicated that there may be localized areas with coarser mean grain size. Borings of the Queen's Gate material were analyzed to determine if significant areas of coarse material were present within the channel, but no clear, consistent area of such material was identified. Characterization data for the Queen's Gate material is found in Appendix F. Also, dredging operations for Queen's Gate and any subsequent placement of the materials in rehandling sites, such as the West Anchorage site within the harbor, resulted in some losses of fines during overflow and placement, with a subsequent coarsening of the material. Modeling had indicated that the Queen's Gate material could be used for cap construction if the conventional method of placement was used. The Los Angeles District also indicated that the finer material mixtures from Queen's Gate may be representative of much of the material available from the borrow areas. Therefore, in the context of the pilot, use of Queen's Gate was appropriate for demonstration of conventional placement techniques with a finer material type available in the Los Angeles region.

Evaluation of A-II and A-III borrow areas. In addition to the Queen's Gate material, coarser sediment from a sand borrow area was also used for the pilot study. Sand borrow areas outside the harbor breakwaters (designated as A-II and A-III) have in situ mean grain sizes in excess of 0.2 mm. However, these materials are also highly variable, and there are environmentally sensitive areas located within the larger borrow areas corresponding to submerged aquatic vegetation (SAV) and rock pinnacles with high fisheries values. LAD obtained borings in selected portions of borrow areas A-II and A-III, with water depths less than 80 ft (to facilitate dredging) and outside known sensitive areas, and used the grain size data to identify a source of coarser material within the A-III area for the pilot.

The A-III borrow site was located approximately 2 nautical miles southwest of the entrance channel dredging area in depths of 22 to 23.5 m. The A-III material consisted of fine and medium grained sand with only trace fines. The sediment has a Unified Soil Classification System (USCS) classification of SP

(poorly graded sand). The range of physical properties is shown in Table 2-1. Detailed characterization data for the A-III material is found in Appendix F.

Modeling conducted prior to final cap material selection indicated that use of mixtures of fine sand and silt/clay cap material (such as material from Queen's Gate) resulted in a larger proportional dispersion offsite, and potentially greater spread downslope as compared to a coarser sand (such as from the sand borrow areas A-II and A-III). Therefore, the finer materials (i.e., the sediments from the Queen's Gate Channel) were selected for placement using conventional release from the hopper dredge. The coarser materials (i.e., the sediments from the A-III borrow site) were selected for placement using a spreading method of placement.

2.1.3 Selection of placement equipment

Hopper dredges were identified as a preferable placement equipment type in Palermo et al. (1999), and use of a hopper dredge was planned for the pilot. Hopper dredges are self-propelled seagoing ships with the molded hulls and lines of ocean vessels. They are equipped with propulsion machinery, sediment containers (hoppers), dredge pumps, and other special equipment required to perform their essential function of removing material from a channel bottom or ocean bed. Hopper dredges have propulsion power adequate for required free-running speed and dredging against strong currents and excellent maneuverability for safe and effective work in rough, open seas. Dredging is accomplished by progressive traverses over the area to be dredged. The dredged material is raised by dredge pumps through drag arms connected to drag heads in contact with the channel bottom and discharged into hoppers built in the vessel. Unloading methods depend on the specific hopper design, usually by opening doors in the bottoms of the hoppers or by using a split hull opening mechanism.

A hopper dredge was the equipment of choice for the pilot study capping on the PV Shelf project for the following reasons:

- a. Hopper dredges were the most readily available equipment for the pilot study work.
- b. Hopper dredges provide better control of placement in the open ocean environment and allow for more flexibility in placement options including pumpout capabilities.
- c. Hopper dredges remove material from channels by hydraulic means, resulting in a breakdown of any hardpacked material, and addition of water as material is stored in the hopper for transport. Material from hopper dredges is therefore more easily dispersed in the water column, and settles to the seafloor with less energy and less potential for resuspension of the contaminated sediment than mechanical dredges.

Dredging for the Queen's Gate navigation channel deepening project in Long Beach Harbor was ongoing during the time frame for developing the pilot study. NATCO Limited Partnership was onsite at the Port of Long Beach from November 1998 to December 2000 deepening the POLB entrance channel under

the Los Angeles District contract. Therefore, contractual arrangements were made with NATCO for the pilot study placements using Queen's Gate sediment. A modification to the existing contract was issued to NATCO in the summer of 2000 to perform the placement operations for the PV Shelf pilot study. This contract modification was in cooperation with the POLB, USACE, EPA, and NATCO. The POLB was willing to accommodate the pilot study as long as their deepening project completion date was not significantly delayed.

The NATCO dredge *Sugar Island* was used for the pilot study placements (See Figure 2-2). The *Sugar Island* has a split-hull hopper opening mechanism that can be incrementally opened (but at a fixed rate) to control the rate of release (the mechanism cannot be closed until the hopper is emptied). This dredge is equipped with bow thrusters that improve its positioning capability and is also equipped with a hopper pumpout capability over the bow and water jets to aid in pumpout operations. Pumpout can also be accomplished through the adjustable skimmers within the hopper. NATCO indicated that, with minor modifications, pumpout could be accomplished through one of the two drag arms, allowing for a submerged point of discharge that would reduce the water column losses of fine sediments. Any of these methods of placement could potentially have been used during the pilot.

2.1.4 Planned cap thicknesses and volumes

Two objectives of the pilot study were primary drivers in determining the target volumes and thicknesses of material necessary for placement for the pilot: a) the need to determine differences in cap material behavior for differing placement options, and b) the need to determine the volume of material required to construct a full design cap thickness over a given area. Time and cost limitations for the pilot study made it impractical to undertake construction of the full isolation cap design thickness of 45 cm for each possible combination of cap material type, water depth, bottom slope, and placement technique. However, the two objectives of the pilot study could still be met with the placement of a cap of less than 45 cm. The pilot study activities were therefore scoped to ensure that the effort remained within budget. This scope revision process continued during the planning and design of the pilot study and as firm cost estimates for pilot study cap placement and monitoring were developed. In determining the final scope of activities, both reductions in the level of monitoring effort and reductions in the total volumes of material placed by location or by method were considered.

The pilot study included a combination of multiple placements to form a cap over portions of the capping cells. It was determined that the necessary data on various placement methods and variable material types could be obtained from a limited number of hopper placements, i.e., placing a small volume within a cell rather than constructing a complete cap over the entire cell. The most likely placement method and material type to be employed full scale was evaluated for construction of a full cap design thickness over a sufficient area to determine the process of cap thickness buildup for adjacent placements. Since the bottom slope only slightly increases with water depth for areas between the 40- and 70-m

depth contours, it was deemed that a comparison of shallow and deeper placement areas for the pilot study would provide the needed information for both depth and to some degree, bottom slope.

2.1.5 Plan for placement operations

Placement of a relatively small volume was deemed sufficient to observe the differences between conventional versus spreading placement methods, finer versus coarser material types (cap material sources), and shallow versus deeper cells. Based on the modeling conducted in Palermo et al. (1999), the spreading method of placement was chosen for the coarser material type. Placement of coarser material using conventional methods was not considered desirable, at least for the initial layer of cap material, because of the higher potential for sediment displacement and resuspension due to an expected higher impact velocity.

Removal of large volumes from the sand borrow area would have required extensive and time-consuming studies to completely delineate the deposit and acquire needed permits because of the potential environmental impacts of a large project. Further, large volumes of coarse material had not been identified within the scope of the current Queen's Gate project. For these reasons, placement of coarser material for a full cap thickness over a large area was not anticipated for the pilot, and the placement of coarse material was evaluated with nine hopper load placements to build a cap over an area along one spreading track line. These placements were planned consecutively to confirm the rate of buildup of cap thickness and spreading and dispersion behavior. Similar placements using spreading were originally planned for both Cells LD and SD, but placements in SD were eliminated in the pilot study scoping process. Data for comparison of spreading methods in shallow versus deep cell placements were therefore not collected, but the placements in Cell LD and LU did allow for comparison of spreading methods versus conventional placements, considered more critical in meeting the overall pilot study objectives.

The total volume of coarse material to be dredged from the borrow area had to be estimated for purposes of preparing the environmental assessment (EA). The anticipated hopper load from the sand borrow area for the *Sugar Island* class of dredge is approximately 1,400 cu m (hopper or bin volume).¹ Considering the originally planned placement of coarse cap material in both shallow and deep cells, a total volume of approximately 20,000 cu m (in hopper volume) was used for the EA.

A multiple placement scenario (approximately 10 hopper loads) was also planned to determine the behavior of Queen's Gate material placed at the greater water depth in cell SU using conventional placement methods. These placements would be located in the central area of the cell between the 62 and 65-m depth contours. A full cap thickness placement was originally planned for Cell SU, but the volume of placement was reduced in the pilot study scoping process.

¹ Personal communication with Bill Pagendam, NATCO.

Although full-scale cap construction in a deeper cell was not conducted as part of the pilot study, the multiple placement volume in Cell SU did provide data on the rate of buildup of cap thickness and spreading and dispersion behavior for the deeper cell versus the shallow cell using conventional placement methods.

Designs of 15 cm for a thin cap and 45 cm for an isolation cap were recommended in Palermo et al. (1999). The pilot study plan included sufficient material to determine if these cap thicknesses could be constructed over a larger area with acceptable rates of buildup and acceptable variability in cap thickness, considering the overlapping effect of adjacent placements. The major consideration here was to observe the rate of sediment accumulation as a function of distance from clusters of individual hopper dredge placements. It was not necessary to construct a full 45-cm cap thickness to obtain the needed field data on full design cap placement. If a 15-cm cap could be constructed over a large area, then the same methods of placement could be used to construct a 45-cm cap.

Data on placement behavior for the full design cap thickness were considered desirable for both shallow and deep pilot study cap placement areas. However, available resources only allowed for placement of a full 15-cm cap thickness within one cell. The source of fine-grained cap material was Queen's Gate and this material source was used to build the 15-cm cap thickness in the shallow upstream cell (Cell LU). A 15-cm coverage over one 300 by 600-m cap cell equates to 27,000 cu m in-cap volume. To accumulate this thickness uniformly over a total cell, a larger volume must be placed, with some of that material going onto adjacent cells and some being lost during placement. Prior experience with the Queen's Gate project indicated the in-hopper settled volumes were roughly equivalent to the in-source volumes, and the typical hopper load was about 925 cu m (in-source volume). Approximately 42,000 cu m in-source volume was the planned volume to construct a 15-cm cap over the entire cell and a full 45-cm cap over a portion of the cell.

The OMP called for measures to minimize potential disturbance by only placing cap directly on the EA sediment with the initial hopper load in each cell. Following this first hopper load, the next several would be directed to the same location so that disturbance of the EA sediment was insulated by the sediments already in place from the first load. From that point on, all subsequent placements would always occur over cap sediments that already had reached their position on the seafloor through lateral spreading.

2.2 Environmental Coordination

The proposed capping operations for the pilot study and the associated requirements to dredge capping material from the Queen's Gate Channel and other borrow sites required appropriate environmental coordination and the preparation of several environmental coordination documents. NEPA was established to ensure that environmental consequences of Federal actions are incorporated into agency decision-making processes. NEPA establishes a

process whereby parties most affected by impacts of a proposed action are identified and opinions solicited. Under NEPA, the proposed action and several alternatives are evaluated in relation to their environmental impacts, and a tentative selection of the most appropriate alternative is made.

Use of the Queen's Gate dredged materials for the pilot study involved modifying a previously assessed project (the Port of Long Beach's main channel deepening project). An Environmental Impact Statement (EIS) (USACE and POLB 1995) prepared for the underlying channel deepening project was completed September 1, 1995, and the Assistant Secretary of the Army signed a Record of Decision (ROD) for the Queen's Gate Channel deepening on March 4, 1997. A Supplemental Environmental Assessment (SEA) was prepared to address impacts and develop mitigation (if warranted) associated with proposed modifications to accommodate the pilot study capping project, i.e., dredged material transport to the PV Shelf. Similar to the EIS process, the draft SEA was circulated for public review. Comment responses were incorporated into a final SEA (USACE 2000a) and the Los Angeles District Engineer signed a Finding of No Significant Impact (FONSI) on May 18, 2000.

The dredging and transport to the PV Shelf of sand obtained from borrow site A-III was assessed as a new and separate, although related, project. An EA was prepared to address impacts and develop mitigation (if warranted) associated with the proposed dredging of cap material and transport to the PV Shelf. The draft EA was circulated for public review. Comment responses were incorporated into a final EA (USACE 2000b) and the Los Angeles District Engineer signed a Finding of No Significant Impact (FONSI) on August 8, 2000. All environmental coordination documents prepared for the pilot study are included as appendices.

An environmental information document was prepared by the EPA at the request of the California Coastal Commission to facilitate their comments on the pilot study. The cap construction phase of the pilot study capping study was the subject of this environmental information document. The environmental information document, taken with the SEA and EA previously discussed, evaluated the environmental impacts of the field pilot study. The California Coastal Commission concurred with its findings in a public hearing held on June 14, 2000.

An assessment of Essential Fish Habitat (EFH) for the field pilot study was prepared in conformance with the 1996 amendments to the Magnuson-Stevens Fishery Management and Conservation Act (see Federal Register 62(244): December 19, 1997). The 1996 amendments to the Magnuson-Stevens Act set forth a number of new mandates for the National Marine Fisheries Service (NMFS), eight regional fishery management councils (Councils), and other Federal agencies to identify and protect important marine and anadromous fish habitat. The Councils, with assistance from NMFS, are required to delineate EFH for all managed species. Federal action agencies which fund, permit, or carry out activities that may adversely impact EFH are required to consult with NMFS regarding the potential effects of their actions on EFH, and respond in writing to the fisheries service's recommendations. This document was prepared

and sent to the NMFS in June 2000. NMFS did not recommend any additional measures. All environmental coordination documents are included in Appendix E.

2.3 Dredging and Cap Placement Operations

2.3.1 Dredging methods

A dredging event would begin when the *Sugar Island* was positioned in the selected dredging area. The drag arms would be lowered to the bottom with the water jets activated to help cut the dredged material. Once the drag arms contacted the bottom, the dredging process commenced, and, within a few moments, a slurry of water and sand would start filling the hopper. As the hopper filled with the slurry, skimmers in the hopper were raised or lowered to control the water level of the hopper. A typical dredge cut length was 1,000 m and the *Sugar Island* would make two to three cuts to obtain the desired hopper load of approximately 1,000 cu m of material.

A load chart on the bridge provided an indication of the load in the hopper. At the end of each cut, the drag arms would be raised off the bottom but still remained submerged while the *Sugar Island* turned to commence the next cut. Once the *Sugar Island* had approximately 1,000 cu m of material in the hopper, the dredging cycle was terminated, the drag arms were raised above the waterline and the dredge headed for the placement (i.e., pilot study capping) site.

An automated electronic tracking system was used to record the location of the dredge during dredging, transit, and placement. This system was able to automatically record the time, duration, and location of each capping event. Further, load volume and placement rates were estimated using changes in vessel draft, which were electronically recorded. A description of these monitoring systems is provided in Chapter 3. Additional details of the date, volume, placement location, and placement duration of each load can be found in Appendix G.

At the POLB Queen's Gate entrance channel, the *Sugar Island* would spend approximately 90 min dredging to obtain a load, followed by a 65-min transit to the PV Shelf area and 5 to 10 min performing a point placement, followed by a 60-min return to the channel for a total cycle time of about 3 hr and 45 min. Measured loads varied from 650 to 1,380 cu m. At borrow area A-III, the *Sugar Island* could obtain a load in approximately 30 min, decreasing the cycle time by 1 hr. The transit time from the A-III site was comparable to the Queen's Gate transit.

The volume of each capping load was determined based upon load curves for the dredge, bin dimensions, and the characteristics of the loaded material. Samples of the cap material were collected and analyzed for each of the first three initial capping loads at each cell plus 25 additional loads during the

continuous capping phase. Analyses on these samples included grain size, bulk density, specific gravity, water content, and Atterberg limits. Additionally, chemical analysis of p,p' DDE was conducted for composite sediment samples from the first three loads acquired from the borrow site A-III. A description of the techniques and results are given in Chapter 3.

Table 2-2 lists the number of placements and types of placement. Dredging operations for the pilot study were coordinated with the monitoring efforts at the PV Shelf site so that the placement would coincide with SAIC's monitoring.

2.3.2 Cap placement methods

There were three different types of placement utilized in the PV Shelf pilot capping project: conventional (point) placement, spreading placement, and direct pumpout through a hopper drag arm.

Conventional placement. The conventional placement method is also referred to as point placement. The intent of the conventional placement method was to release the material essentially at a specified point, such that the spreading of material by movement of the dredge would be minimized. This method was used for placement of the Queen's Gate material. The Captain of the *Sugar Island* was provided with a list or sequence of placements with a specific location (northing and easting coordinates) for each placement. A list of approximately 20 placement locations would be provided to the captain at a time. The point placements took place in Cells LU and SU.

At the placement site, the *Sugar Island* would position itself in the appropriate Cell (LU or SU) and then initiate placement within a 7.5-m radius of the target position. Conventional placement would commence with the mate activating the hydraulic rams, which open the split hull of the dredge. As the hull opens up, the material in the hopper falls into the ocean. Jets of water are directed into the hopper from above to assist the placement operation and dislodge any material that sticks to the side of the hopper. The split hull is opened for about 5 min, and as the load is released and the dredge's draft decreases, the vessel becomes increasingly susceptible to movement by the wind. Once the hopper is empty, the split hull is closed and the dredge starts its transit back to the dredge site.

Spreading placement. The placement by spreading was performed in Cell LD. The intent of the spreading method was to make one pass through Cell LD per load and dispose of the hopper's load evenly over the length of the cell. This method was used for placement of the A-III borrow area sand. The *Sugar Island* would approach Cell LD traveling from southeast to northwest (305 deg) so as to transit down the center of the cell. The *Sugar Island* would decrease its speed to approximately 2 to 3 knots, the minimum speed at which it could maintain its heading. Upon entering the southeast boundary of Cell LD, the captain would crack open the hull of the dredge by activating the hydraulic rams for 3 to 4 sec, and would flush the hopper with jets of water. The load strip chart located on the bridge would be monitored closely to observe the progress of

the placement. If the material was escaping too quickly, some of the water jets would be disengaged, and if the material was not disposing quickly enough, more water jets would be brought on line. At 2 to 3 knots, the *Sugar Island* covered the length of Cell LD in approximately 8 min. There were nine spreading placements in Cell LD. The largest portion of the first three spreading loads was placed along the initial portion of the track line within the first few minutes. After the first three loads, the crew of the *Sugar Island* consistently released the hopper load uniformly over the entire length of the track line during the entire 8-min placement.

Direct pumpout. There was one placement of Queen's Gate sediments by direct pumpout, and this occurred in Cell LC, located between Cells LU and LD. The intent of this placement was to transit down the center of the 600-m length of Cell LC, pumping out material through the *Sugar Island's* starboard drag arm, which was lowered to a depth of 24 m. For this event, the *Sugar Island* carried a load of approximately 750 cu m. It approached Cell LC by traveling down the center of LU. As the *Sugar Island* approached the LU / LC boundary traveling at 2 knots, the captain commenced pumpout operations. The first port gate was opened and material from the hopper dropped into the port side piping and traveled through to the starboard drag arm pump, down into the submerged starboard drag arm. During this one-time direct pumpout trial, the captain attempted to pump out all of the hopper material within Cell LC by adding more water into the hopper and opening up more of the hopper's port gates. As the *Sugar Island* reached the northwest boundary of Cell LC, the pumpout operations were terminated. Approximately 450 cu m of material remained in the hopper. The *Sugar Island* transited to the Long Beach placement area, located inside the Long Beach breakwater, and disposed of this remaining material.

2.3.3 Placement sequencing

The sequence, number of loads, and spacing of the initial pilot study placements were based on the need to observe the basic behavior of single hopper dredge placements for finer versus coarser cap material, seaward versus shoreward cell locations, and spreading versus conventional placement methods. Single hopper loads were placed and monitored prior to placement of multiple loads. In this way, if the behavior of a given placement exceeded acceptable limits on spread or dispersion or resuspension, adjustments could be made to the operation prior to placement of larger volumes over a larger area during the pilot.

The placement/monitoring sequence used for the pilot study is summarized in Figure 2-3 and is described as follows:

Trial placements. Prior to any actual placement at the Palos Verdes Shelf site, releases of the Queen's Gate material with conventional placement methods at the Port of Long Beach (POLB) placement site as a part of the navigation deepening project were observed to determine the nature and rate of release from the hopper. Trial placements of A-III material with the spreading method of placement were also observed at the POLB placement sites to determine the rate of release from the

hopper and any tendency of the material to bridge. These were considered practice releases for purposes of the pilot study and were conducted within Long Beach Harbor. These two spreading method trials were conducted over a 600-m length of the POLB placement area, to match the length of the Palos Verdes Shelf cells. The captain of the *Sugar Island* used these trial runs to confirm the amount that the hopper bin should be cracked opened and how much jetting of water to apply to ensure even spreading of material and also complete placement of the hopper load over a 600-m length.

Single conventional placement in Cell LU. The first pilot study placement was a single hopper load of the finer material from Queen's Gate discharged at the center of Cell LU. This load was placed using the conventional placement method. Approximately 1 week of downtime followed this single placement to allow assessment of the adequacy of the monitoring equipment and techniques, shift instrumentation for the next placement, and analyze the monitoring results for this single placement. This single hopper load was followed later by a 15-cm cap over Cell LU.

Single spreading placement in Cell LD. This placement was a single hopper load discharged along the center line of Cell LD using coarse material from the A-III borrow source. A single load was placed using a spreading method of placement. The direction of travel of the hopper was to the northwest away from the LACSD outfalls to ensure that any overshoot of the placement occurred in an area away from the outfalls. Once the data from a single hopper placement was assessed, additional hopper/barge loads were placed, with the intent of creating a thicker cap using this method.

Fifteen-cm cap thickness in Cell LU. A 15-cm cap thickness was placed over Cell LU once the spreading and dispersion observed for the single placement was deemed acceptable. The 15-cm cap was constructed using conventional placement techniques and finer material from Queen's Gate. Additional hopper placements were made at the same release point as used for single placement until a cap thickness of ~ 15 cm over this location was constructed. Then placement locations were shifted to the next placement point. Spacing between placements of 60 m was recommended in Palermo et al. (1999), and this spacing was refined based on additional modeling. Spacing and sequencing was based on the concept that subsequent placements would take place over existing cap material to reduce the potential for resuspension of the EA sediments. A horizontal spacing of 75 m was used based on the modeling, evaluation of the sediment profile images from the initial placement, and consultation with NATCO and SAIC (see Chapter 4). Placements were conducted around the initial placement, then proceeded to the outer stations. Spacing between lanes was initially set at 60 m. Both the lane and placement spacings were adjusted during the cap placement, depending upon observed rates of buildup.

Multiple placements in Cell LD. Eight additional hopper loads of coarser A-III material were placed in Cell LD using the spreading

method to evaluate the buildup of cap thickness using this material and method of placement.

Single conventional placement in Cell SU. This placement was similar to the single placement in Cell LU except in the deeper seaward Cell SU. A single hopper load of the cap material from Queen's Gate was discharged at the center of Cell SU, which is at a depth of about 62 m. This load was placed using the conventional placement method.

Multiple placements in Cell SU. Twenty additional hopper loads were placed in SU to create a 15-cm cap thickness over a portion of Cell SU. These placements were allowed to proceed once the spreading and dispersion observed for the single placement was deemed acceptable. The placements were conducted using conventional placement techniques and finer material from Queen's Gate. Initial placements started at the center of Cell SU then proceeded clockwise around the initial central placement location.

Full cap thickness in Cell LU. Following monitoring activities for the 15-cm cap placement in Cell LU, additional capping was conducted to build up a thicker cap over the center portion of that cell.

Direct pumpout. A single load discharge using direct pumpout through a dragarm of the dredge was placed in Cell LC (located between Cells LU and LD) and continuing into Cell LD. This load was included to collect data on the relative performance and results for a pumpout placement.

The capping activity conducted during the pilot study is summarized in Table 2-2 (a more detailed summary of placement data is provided in Appendix G).

**Table 2-1
Grain Size Distribution for Designated Borrow Site A-III**

	Minimum	Average	Maximum
% coarse gravel	0	3 ⁽¹⁾	26 ¹
% fine gravel	0	2 ⁽¹⁾	9 ¹
% coarse sand	0	3	9
% medium sand	14	32	55
% fine sand	28	59	81
% fines	0	1	2
D ₅₀	0.24 mm	0.33 mm	0.71 mm

¹ Most of the material indicated as fine and coarse gravel was actually shell and shell fragments.

**Table 2-2
Summary of Cells and Capping Activity by Cell**

Cell	Water Depth	Cap Material	Placement Method	Cap Thickness/Area	No. of Loads	Volume (cu m)
LU	Shallow – 45m	Queen's Gate	Conventional	15 – 45 cm (6 – 18 in.) over entire cell	71	69,815
LD	Shallow – 45m	Borrow Site	Spreading	≤10 cm in center lane only	9	10,325
LC	Shallow – 45m	Queen's Gate	Pumpout through drag arm	N/A (1 load only)	1	300
SU	Deep - 60 m	Queen's Gate	Conventional	15 cm in center portion of cell	21	22,810
				TOTALS	102	103,250

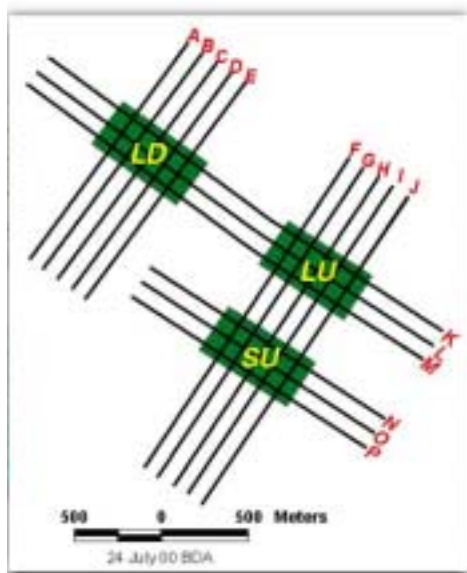
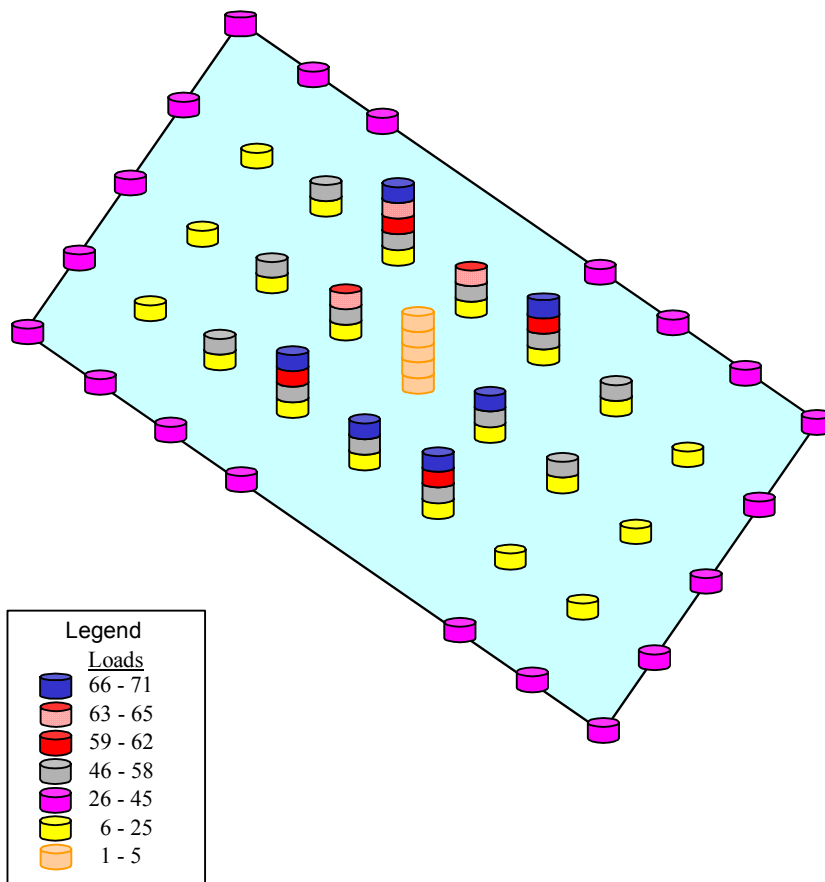

Figure 2-1. Relative locations of pilot study capping Cells LD, LU, and SU

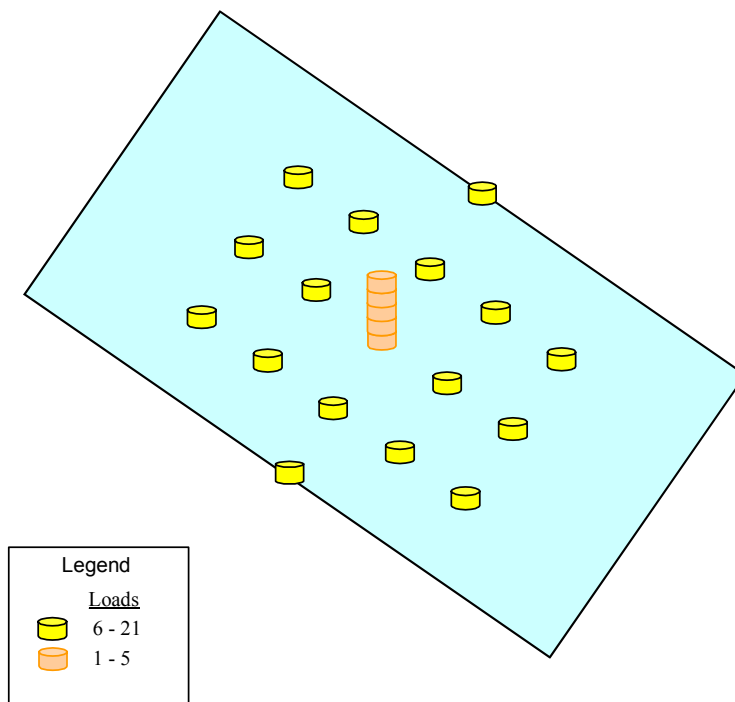

Figure 2-2. Photos of the hopper dredge *Sugar Island*, showing filling and cap placement operations



a. Cell LU

Figure 2-3. Sequence of cap placement



b. Cell SU (SIMPLE VERSION)

Figure 2-3. (Continued)

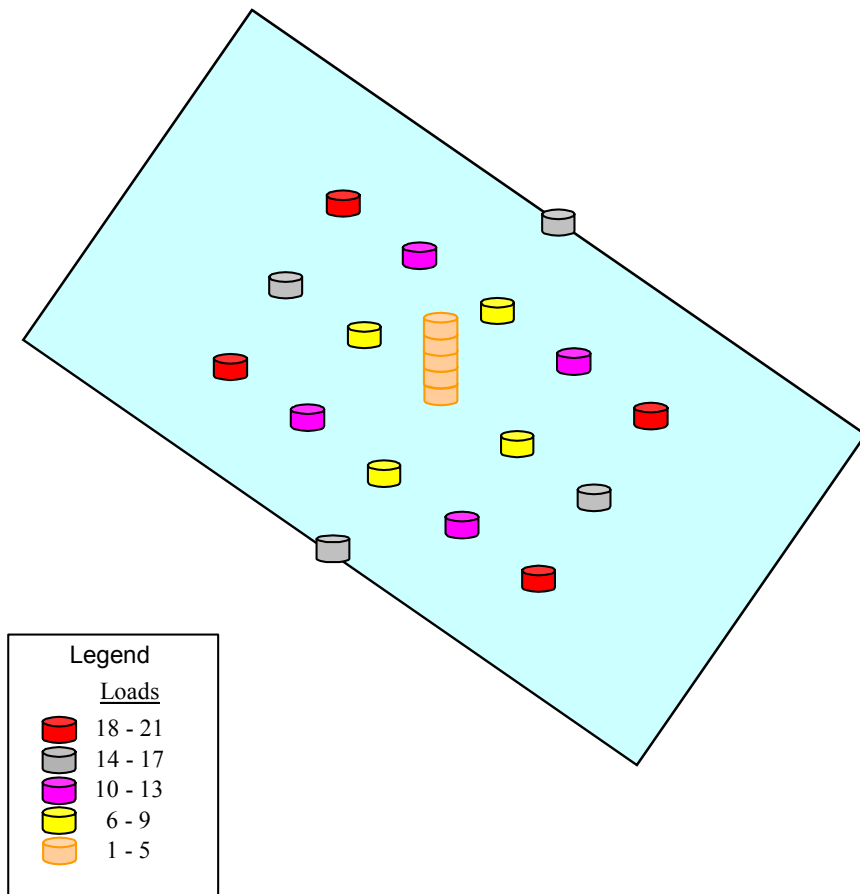

c. Cell SU (DETAILED VERSION)

Figure 2-3. (Concluded)

3 Monitoring Activities and Results

- 3 Monitoring Activities and Results 3-1
 - 3.1 Introduction 3-2
 - 3.1.1 Monitoring requirements 3-2
 - 3.1.2 Key questions addressed 3-3
 - 3.2 Monitoring Teams, Vessels, and Logistics 3-5
 - 3.2.1 Monitoring teams 3-5
 - 3.2.2 Field facilities 3-5
 - 3.2.3 Survey vessels 3-6
 - 3.2.4 Monitoring time line and operations 3-6
 - 3.2.5 Data management and availability 3-8
 - 3.3 Monitoring Program Components 3-9
 - 3.3.1 Baseline data collection 3-9
 - 3.3.2 Construction monitoring 3-9
 - 3.3.3 Postconstruction monitoring 3-10
 - 3.4 Monitoring Equipment and Techniques 3-11
 - 3.4.1 Navigation and vessel positioning 3-11
 - 3.4.2 Hopper dredge operations 3-11
 - 3.4.3 In-hopper cap material characterization 3-12
 - 3.4.4 Plume mapping 3-13
 - 3.4.5 Water quality sampling 3-13
 - 3.4.6 Surge measurements 3-14
 - 3.4.7 Cap characterization 3-15
 - 3.5 Baseline Monitoring Results 3-17
 - 3.6 Construction Monitoring Results 3-19
 - 3.6.1 In-hopper cap material characterization 3-19
 - 3.6.2 Cap construction 3-20
 - 3.7 Cap Placement Monitoring Results 3-28
 - 3.7.1 Surge monitoring 3-28
 - 3.7.2 Near-bottom plume tracking 3-29
 - 3.7.3 Near-surface plume tracking 3-30
 - 3.8 Postconstruction Monitoring Results 3-30
 - 3.9 Assessment of Results Relative to Key Questions 3-32
 - 3.9.1 Can a uniform cap be constructed? 3-32

3.9.2	Can disturbance to in-place sediments be kept within tolerable limits?	3-37
3.9.3	Does the cap remain clean?	3-41
3.9.4	Does the cap remain stable during placement?	3-42

3.1 Introduction

The project team developed a monitoring program, consisting of multiple interrelated elements, to evaluate (a) the behavior of the cap during the different placement conditions, (b) water quality impacts, (c) cap distribution, and (d) impacts to the in-place EA contaminated sediments. The monitoring activities and results presented in this chapter comprise a summary of the principal elements from the in-depth monitoring report prepared by the contractor (SAIC 2001), as well as brief descriptions of the tools and approaches used. Full descriptions of the techniques and equipment are found in the Project Work Plans (SAIC 2000a, 2000b). Further detail on some of the monitoring elements (such as individual sample data, full current meter records, etc.) are contained within the project database incorporated into the Disposal Area Network for Los Angeles (DAN-LA) data management system. Monitoring activities were conducted in three principal phases:

- a. Baseline
- b. Construction
- c. Postconstruction

The monitoring covered in this report was conducted from May 2000 to March 2001.

3.1.1 Monitoring requirements

The Project Work Plans (SAIC 2000a, 2000b) laid out the overall monitoring approach and included Monitoring Scopes of Work that organized the effort into tasks and listed monitoring equipment and techniques to be used. A separate Operations and Monitoring Plan (Palermo 2000) described the overall approach to the pilot study implementation. Close coordination and advance planning were required among the USACE management team, the dredging contractor, NATCO, and the monitoring program contractor, SAIC, to ensure that the operations plan and monitoring scopes of work were appropriately meshed.

The monitoring carried out during the pilot study capping activities focused on feasibility of constructing the cap and the short-term potential impact to the seafloor, water column, and nearby resources, such as kelp forests. As discussed in Chapter 1, the monitoring program was not designed to address longer-term questions such as recolonization, bioturbation, or response to storm or seismic events. These longer-term items are being addressed separately by EPA.

3.1.2 Key questions addressed

The monitoring program was designed to address several of the pilot study objectives directly related to cap placement as listed in Chapter 1. Five key short and intermediate term questions relative to capping on the Palos Verdes Shelf were central to meeting these objectives:

- a. Can a uniform cap be constructed?
- b. Can disturbance to in-place sediments be kept within tolerable limits?
- c. Does the cap remain clean?
- d. Does the cap remain stable during placement?
- e. Does placement occur as modeled?

Each of these questions (with slight variation in wording) and the generic monitoring approach was addressed in Appendix F of Palermo et al. (1999), but the environmental concerns that relate to these issues are summarized here. The detailed scopes of work to accomplish this monitoring are provided in Appendix D.

Can a uniform cap be constructed? This question involved the ability to place multiple loads of sediment over an area without exceeding an acceptable range of variation in cap thickness. An issue was how effectively parameters under our control were adjusted (such as placement method or type of cap material) in order to overcome any adverse effects on construction that were a function of things beyond our control (such as water depth, EA sediment characteristics, or bottom slope). The ability to control placement was assessed both during the series of hopper placements and once they were complete using tools to measure the thickness and spread of the resulting cap on the seafloor.

Can disturbance to in-place sediments be kept within tolerable limits? Sediments released from the placement vessel passed through the water column, reached the seafloor, and then spread laterally. These processes have usually been referred to as the convective descent and dynamic collapse phases (Figure 3-1). The energy possessed by the falling mass of sediment had the potential to disturb the in-place sediments both at the direct point of impact, and to a lesser degree in the area where lateral spread occurred.

The amount of disturbance to the EA sediments was assessed both at the point of impact and in the area of lateral spreading. A sediment profile camera and coring were the principal methods used to assess this level of disturbance. In particular, the absence or thickness of the sediment's oxidized layer, which was measured prior to placement, provided a very good marker for this assessment.

A second concern regarding disturbance of the in-place sediments was the effect on water quality. Because of the operational approach for material placements, resuspension of EA sediment was expected to be greatly reduced after the initial placement, but the amount of contamination in the near-bottom plume (associated with the dynamic collapse) was monitored to assess this

expectation. This effort involved tracking the plume and measuring suspended solids and contaminant concentration relative to baseline conditions.

Monitoring of contaminant concentrations focused on measuring of the primary breakdown product of DDT: p,p' DDE. This particular DDE isomer was selected by the project team as a tracer for the EA sediments because of its high concentrations in the EA sediments and because it is known to co-vary with the concentration of other sediment contaminants such as PCBs (Lee 1994). Throughout this report references to DDE concentrations refer specifically to the isomer p,p' DDE.

Does the cap remain clean? In the short and intermediate term this question was addressed as part of the assessment of mixing of the EA and cap sediments. Both coring with chemical analyses of DDE and observations of sediment features in the sediment profile photographs were useful for evaluating whether the cap was placed with minimal mixing. Some presence of contaminants in the cap was expected because of the natural resuspension and transport of EA sediments that occurred during the cap construction process. However, the monitoring was designed to measure the levels that can be expected immediately after capping. These data will then be useful for determining any changes in the sediment or contaminant profiles in future cores.

Does the cap remain stable during placement? The stability of the cap both during and immediately after construction was determined by the combination of surveys to assess the distribution of the cap over the EA deposit. Bottom-mounted instrument arrays were used to document the changes in bottom current speeds (lateral surge) that occurred during the placement process. Side-scan sonar, sediment profile photography, and coring were used to map the actual extent of the deposit on the seafloor. Side-scan sonar, in particular, was used to assess the downslope spread of material that would have suggested occurrence of turbidity flows. Side-scan sonar and sub-bottom profiling were also used to help confirm the absence of any major seafloor changes (e.g., gullying, heaving) that could have resulted from either turbidity flows, mud waves, or large-scale seafloor deformations.

Does placement occur as modeled? This question and its implemented monitoring program incorporated several concerns that have been raised about the placement of sediments from vessels at the ocean surface onto the seafloor. These concerns included the following:

- a. How far the sediments spread
- b. How thick the material was after it came to rest on the seafloor
- c. The effect of water depth, bottom slope, and cap material type

For example, the model predicted that one hopper load of sediment placed by split-hull methods would produce a seafloor deposit approximately 500 m in diameter with a maximum thickness of 3 cm at the center and thinning to 0.1 cm at the edge. Several monitoring tools, as described in the following section, were used to measure the actual distribution and thickness of the deposit during the

pilot project. Combined, these enabled an assessment of how actual field conditions reflected those predicted by the model.

3.2 Monitoring Teams, Vessels, and Logistics

3.2.1 Monitoring teams

In addition to the overall project team described in Chapter 1, composed of the USACE, USEPA, and the contractors who were onsite during various portions of the cap placement and monitoring activities, several discrete sub-teams were created by SAIC to carry out the specific monitoring tasks. These included a navigation team to collect data on the monitoring vessels' positions during survey activities, a team to measure physical and chemical conditions, a plume mapping team, a physical oceanographic team, a seafloor photography team, a broad-scale seafloor mapping team, and a cap placement positioning team. Another team was responsible for data management and mapping.

Teams were responsible for mobilizing equipment, obtaining necessary supplies and sample containers, coordination with other teams, deployment and retrieval of instrumentation, field collection of data in accordance with monitoring plans, onsite and offsite data analysis, coordination with sub-contractors (e.g., sample analysis labs), and interpretation and reporting of results. Activities and monitoring/sampling tools used by these teams are described in the following sections.

3.2.2 Field facilities

The Southern California Marine Institute (SCMI) Fish Harbor Facility was used for overall project coordination, vessel access, equipment mobilization and demobilization, and short-term storage of equipment and field supplies. The SCMI facility, located in San Pedro, CA, provided easy access to the project site (Figure 3-2). The facility has more than 1,200 sq m (13,000 sq ft) of usable space, including offices, classrooms, fully equipped laboratories, and a machine shop (Figure 3-3). Additionally, SCMI has 900 sq m (10,000 sq ft) of deep harbor space to accommodate five research vessels.

The SCMI field facility was used to: a) split and log sediment cores, b) process sediment core and water samples for shipment to the analytical laboratories, c) process sediment profile and plan view photographs for quick analysis of seafloor characteristics and cap thickness during the monitoring effort, d) perform data processing and analysis of side-scan sonar and sub-bottom sediment profile data, e) mobilize other monitoring equipment and f) perform data management activities. Additional warehouse and staging areas provided access for equipment mobilization and demobilization.

Meeting rooms and offices at SCMI provided access for SAIC personnel to compile and process data prior to delivery to the project team (Figure 3-4). The

machine shop, fork lifts, and other equipment at SCMI were used for vessel mobilization activities, as well as facilitating necessary equipment testing and repairs.

3.2.3 Survey vessels

The stringent schedule requirements and the technical complexity of the baseline and summer monitoring program required the use of several marine survey vessels (Table 3-1). Quite often, multiple vessels were used simultaneously during the interim and postcap monitoring activities.

The five vessels used ranged from 9.5 to 12 m (40 to 76 ft) in length, and were equipped with A-frames, winches, and deck equipment (for example see Figures 3-5 and 3-6). All vessels operated with experienced crews specializing in multidisciplinary marine science surveys in the Southern California area, including the coring, sediment vertical profiling, side-scan sonar and sub-bottom sediment profiling technologies employed during the pilot study. The first postconstruction monitoring survey involved the use of a sixth survey vessel. All vessels were outfitted with SAIC's portable Differential Global Positioning System (DGPS) navigation equipment for each survey.

3.2.4 Monitoring time line and operations

Monitoring occurred in three separate phases; baseline, construction, and postconstruction. This report primarily focuses on the baseline and construction results. Postconstruction monitoring will primarily occur in the future, though the first postconstruction monitoring event is briefly discussed in this report.

Pilot capping cells were monitored very intensively in both time and space. Monitoring consisted of tools that allowed mapping of seafloor and water column conditions (see section 3.4) prior to, during, and following cap placement. Some survey techniques consisted of tools that were used along survey lanes that extended across the cells (Figure 3-7). These were complemented with a dense array of point sampling stations at which multiple data types were collected (Figure 3-7). Stations were often sampled repeatedly through time as capping progressed to document changes that occurred. Additionally, extra floating stations and surveys were incorporated into the monitoring approach to allow for more detailed investigations when a need was determined by the monitoring team. One of the sampling techniques involved using bottom instrument arrays to collect time series water column data over periods of hours to days during placement events (Figure 3-8), while other techniques involved following the suspended sediment plume and taking discrete samples of the water column.

The majority of baseline monitoring was conducted prior to any cap placement activities in each cell. Collection of these data provided information on the existing site conditions to aid in the interpretation of changes that occurred as a result of cap placement activities. Most of the baseline monitoring took place in May 2000 (e.g., coring, side-scan sonar surveying, and sub-bottom

sediment profiling). Other baseline monitoring occurred immediately prior to the first placement event in each cell because some of the data collected by these techniques (sediment profile imaging and plan view photography) may vary seasonally (e.g., sediment oxygenation depth). Baseline monitoring of water column conditions occurred just prior to placement events for which plume monitoring was conducted.

Construction monitoring consisted of data collection during, between, and immediately following the placement of cap sediment in the pilot study cells. This included collection of data from the hopper dredge (e.g., position during placement, samples of hopper sediment) as well as collection of data from in and around the pilot study capping cells. Construction monitoring was further subdivided into:

- a. Initial monitoring after the first load in each cell
- b. Interim monitoring which took place after a certain number of cap loads had been delivered to the cells
- c. Final monitoring which took place within hours or days of the final cap load in each cell

One postconstruction monitoring survey was conducted beginning in February 2001 and continuing into early March (February 2001 survey). This first postconstruction survey attempted to obtain cores with less disturbance artifacts than those that had been obtained during the construction monitoring surveys in order to better quantify cap thickness in the cells.

Mobilization for the summer monitoring began in July 2000 and consisted of setting up the laboratory and data processing facilities, as well as assembling, installing, testing, and calibrating the field equipment. A graphical time line of cap placement and the major monitoring activities for Cells LU, SU, LD, and LC provides a quick synopsis of the amount of activity that occurred between the first summer monitoring survey on 27 July 2000 and the last on 15 September 2000 (Figure 3-9). An additional series of graphics provide greater detail on the number of cap loads placed and the monitoring activities undertaken for each cell (Figures 3-10, 3-11, 3-12, and 3-13). These time-line graphics simplify what was, in fact, a very demanding, complex, and intensive field monitoring program. Specific dates of the surveys, stations, or cap placement events are found in the monitoring cruise report (SAIC 2000c) and in the project schedule spreadsheet in Appendix H.

Each primary cell (LU, SU, and LD) first received a single capping load that was intensively monitored before any additional loads were placed. Each initial load was also monitored with the bottom-deployed instrument arrays. The plumes created by the release of the cap material and its impact on the seafloor were tracked and sampled. The first cap placement event occurred in Cell LU (Figure 3-9) on 2 August 2000 followed by the single placement event on 8 August 2000 in Cell SU and 15 August 2000 in Cell LD. This provided the project team with the opportunity to increase confidence in our assumptions

about cap material and EA sediment behavior and to assure that no unforeseen circumstances had occurred before proceeding with any further placement of cap.

Once the preliminary data on the distribution and thickness of the cap deposit on the seafloor and the current surge from these events were reviewed, four additional capping loads were sent to the center of LU on 13 August 2000. The bottom instrument arrays were deployed for these events and plume tracking surveys were also conducted. These additional four loads were followed by a single placement event in Cell LD on 15 August 2000 and then four more placement events in Cell SU on 18 August 2000. Again, the data from monitoring these events provided strong evidence that proceeding with capping should follow our expectations. Once these intensively monitored placement events were completed, the placement and monitoring for the remainder of the cap placement was choreographed among the three primary cells and Cell LC. A single pumpout event in Cell LC occurred on 8 September 2000. A total of 102 cap placement events were conducted in the four capping cells, using three different placement techniques, two different cap sediment types, in cells at two different depths and surface slopes (Table 2-2).

The first postconstruction monitoring survey was conducted in February and March 2001, to collect additional cores and sediment profile and plan view photographs. A primary objective of this survey was to attempt to overcome some of the sample-disturbance artifacts that had occurred with the gravity corer used during the summer program by switching to a vibracorer and box corer. Cores and sediment profile photographs were collected in and around Cells LU, SU, and LD.

3.2.5 Data management and availability

Project data archive within DAN-LA Project GIS. The DAN-LA was developed by SAIC for the Los Angeles District as a GIS providing direct access to data collected during the pilot study cap monitoring program. DAN-LA is designed to allow PC-based, desktop access to data by multiple users, each having a copy of DAN-LA and ArcView® on separate PCs, and provides customized tools that support analyses of monitoring data, modeling, and near real-time management of capping operations. Data updates and distribution of project data were provided. DAN-LA is the archive for all data processed for the pilot study.

Palos Verdes Internet Web site. A project Web site was also developed and maintained by SAIC to provide efficient access for the PV team to information relevant to the cap placement monitoring program (Figure 3-14). This greatly facilitated discussion of the data by the monitoring team. In particular, background documents (e.g., scopes of work, PWPs, schedules, and communication plans) and monitoring data (e.g., cap distribution maps, sediment-profile imaging (SPI) and PVC photos) were posted. Data from the Automated Disposal Surveillance System (ADISS) system were available on the Web site within days of collection, which could then be used by USACE for input to cap placement modeling. Core photographs and core logs, and sediment

profile and plan view camera images also provided qualitative and quantitative data about cap thickness and horizontal coverage. Spatial data were GIS-based to provide geographical accuracy for all program elements. Access to the Web site was password-protected to maintain the security of the data. The November 2001 version of the Web site is contained in Appendix L.

3.3 Monitoring Program Components

3.3.1 Baseline data collection

Baseline monitoring of the area in and around the pilot study cells was conducted to provide a more detailed basis for evaluating cap success than possible based on the historical sampling that had been done in the region (e.g., Lee 1994; LACSD 1995, 1998). This historical monitoring, although useful for initial planning purposes, was not specifically concentrated in the area of the cells to provide sufficient comparison to the data that would be collected during the pilot study operations.

Data collected during baseline monitoring included (a) documenting the characteristics of the cap material in the hopper dredge, (b) mapping the horizontal and vertical distribution of sediment geotechnical, physical, and chemical properties using coring, (c) establishing the baseline features of the seafloor using a side-scan sonar and sub-bottom sediment profiling system, and (d) determining the condition of the preproject sediment column and surface features using sediment profile and plan view photographs.

3.3.2 Construction monitoring

Construction monitoring was conducted very intensively throughout the project. In each cell a single load of cap was placed and initial monitoring was conducted before any subsequent cap loads occurred (Figure 3-9). This gave the project team the opportunity to confirm that cap material behaved as expected before proceeding with further placements. These single events in Cells LU and SU were followed by four more loads of cap, after which extensive interim monitoring was conducted. The project team further evaluated the results from these operations before proceeding to full-time capping. During the near-continuous cap placement operations, additional interim surveys occurred to continue to document and assess the development of the caps and the spacing and distribution of cap loads. Following the placement of all of the cap material into the cells (with some minor exceptions), final cap placement monitoring surveys were conducted.

Monitoring during construction of the caps in the pilot study cells involved using a number of different monitoring tools (as described in the following paragraphs) to address the study objectives. For example, model verification data were collected using a combination of the techniques including dredge hopper

data to document load size and placement position and rate; bottom-mounted arrays to measure the current speeds and suspended sediments during individual placement events; sediment profiling, plan view photography, and coring to measure cap thickness and distribution; and side-scan sonar surveying to measure cap distribution. Additionally, tracking and sampling of the plumes involved use of a ship-towed acoustic backscatter profiling system, and vertical profiling with a transmissometer and a sampler for collection of discrete water samples. Concerns about large-scale seafloor disturbance were assessed with the bottom-mounted arrays, the side-scan sonar system, and the sediment profile and plan view photography equipment.

Overall, the various monitoring tools described in the following paragraphs were used to (a) guide and document the geographic positioning of cap placement events, (b) measure the extent and thickness of the cap, (c) assess impacts to water quality as a result of cap placement, (d) measure the bottom current surge created by cap placement, (e) detect any major morphological changes to the seafloor around the cells, and (f) document the direction and magnitude of plume excursion (Table 3-2).

3.3.3 Postconstruction monitoring

Postconstruction monitoring will continue the evaluation of the caps in response to the natural and anthropogenic processes that occur on the shelf. These will include changes to the sediment column as a result of sediment transport by currents (cap erosion and deposition of new sediment), mixing of the sediment by benthic organisms and chemical migration, and response to storm or seismic events. Post-construction monitoring will be an ongoing activity, though the first such monitoring event was conducted in February 2001.

This February 2001 monitoring event involved the use of the sediment profile and plan view cameras, a vibracore, and a box core. Use of the gravity corer during the summer monitoring had resulted in significant sample disturbance artifacts, so some early postconstruction monitoring was deemed to be a useful addition to the summer 2000 monitoring. The objectives of this monitoring were:

- a.* Evaluate and document the ability of the vibracore to take relatively undisturbed samples and make adjustments in sampling procedures to improve performance.
- b.* Compare the effectiveness with which samples are collected with both a vibracore and box core to assess potential coring artifacts.
- c.* Measure and map cap thickness in Cells LU, SU, and LD using the most effective means available.
- d.* Evaluate the chemical and physical characteristics of the cap material to assist in assessing cap success and the baseline postcap condition. Some of these data (e.g., bulk density of cap) would also be used in ongoing model refinement efforts.

3.4 Monitoring Equipment and Techniques

This section provides a brief summary of the monitoring approaches and equipment used during the monitoring program. More detailed discussions of the methodologies are contained in the Project Work Plans in Appendix D (SAIC 2000a, 2000b) and the field monitoring reports in Appendices I and J (SAIC 2001).

3.4.1 Navigation and vessel positioning

Accurate positioning of the survey vessel during all sampling activities was an essential requirement for the monitoring program. This positioning capability included: (a) presurvey establishment of accurate positions for all sampling locations and survey lanes; (b) a real-time helmsman display of vessel position to aid the vessels' crews in maneuvering to predetermined stations and lanes; and (c) acquisition and automatic digital recording of accurate vessel positions for the duration of each survey. Vessel positioning accuracy of ± 3 m was achieved during the surveys using the U.S. government-maintained Global Positioning System (GPS) with enhancements to positioning accuracy that were achieved using differential GPS (DGPS) corrections provided in real-time by U.S. Coast Guard (USCG) transmitters located in San Diego and Point Conception, CA. A single master time clock was kept that had been precisely set to Greenwich Mean Time (GMT), which was 7 hr earlier than local Los Angeles time. All navigation systems were synchronized with this master time clock on a daily basis. This synchronization was especially important for surveys of cap placement surge and plume dynamics where multiple instruments and/or vessels were collecting data simultaneously.

For all surveys, SAIC installed, operated, and maintained the DGPS navigation systems aboard the survey vessels (Figure 3-15). Identical hardware and navigation software were used for all surveys to ensure positioning accuracy and data format compatibility. An industry standard software product, Hypack®, was used for survey vessel positioning on all surveys. This product has a simple user interface for entry of target station locations and survey lanes, as well as real-time display and data recording capabilities. The GPS and DGPS receivers were interfaced to a personal computer for real-time display of vessel positions and data storage.

Sample positions and associated data were eventually entered into a GIS, which made navigation accuracy extremely important for data consistency and interpretation. This provided confidence when overlaying data sets that were collected on different vessels (hopper dredge and multiple survey vessels) on different days to create composite maps.

3.4.2 Hopper dredge operations

The ADISS, an electronic navigation tracking system, (Figure 3-16) was installed on the hopper dredge, *Sugar Island*. The ADISS system integrated the

data on vessel position, time, hopper dredge draft, and pump data. The components of ADISS included:

- a. GPS and DGPS receivers for acquisition of time and position data
- b. Submersible pressure sensor to determine hopper dredge draft
- c. Programmable logger with time, position, and pressure thresholds of sampling
- d. Flash memory card for storage and portable downloading of data files

Accurate hopper dredge position and time data were collected using signals received from the GPS during the transit and cap placement operations. Like aboard the survey vessels, improved position accuracy was achieved via DGPS (accuracy was approximately ± 3 m).

Hopper dredge draft and pump data were collected to identify where sediment collection and placement occurred. The draft data were obtained during the vessel loading and placement operations. Pump data were collected with a manually-operated switch to determine when the vessel was loading and emptying. Both inputs were used to determine when the load left the hopper. Using the time, position, draft and pump data, the rate of sediment discharge was determined at the capping sites.

In addition to the ADISS equipment installed on the hopper dredge, a helmsman display (ADISSPlay) was interfaced with ADISS to provide the dredge's operator with visual position and bearing information relative to the capping cells and target placement positions. ADISSPlay displayed the vessel position over a National Oceanographic and Atmospheric Administration/ National Ocean Service (NOAA/NOS) chart with superimposed plots of cell boundaries, and recorded the data for each placement event to its database. ADISSPlay components included:

- a. Laptop computer and display/logging software
- b. Manual vessel bearing inputs
- c. Color printer to plot vessel draft and track lines

3.4.3 In-hopper cap material characterization

Samples of the cap material were collected from the dredge hopper to determine the characteristics of this sediment prior to its placement at the capping cells. Samples were collected using a grab sampler lowered to the sediment surface once the dredging phase was complete (Figure 3-17). This was conducted at three locations around the hopper bin, and the individual grab samples were then combined to create one composite sample per load. Initially for each cell, cap material samples were collected from each of the first three loads. Thereafter, 26 additional loads were sampled during the course of operations (19 of the loads placed in LU and seven in SU). All samples were

analyzed for grain size, bulk density, specific gravity, and water content. Samples of the first three hopper loads from the A-III borrow site were also analyzed for p,p' DDE. As previously discussed, the contaminant p,p'DDE was selected by the project team as the tracer for the EA sediment.

3.4.4 Plume mapping

Plume mapping surveys were conducted to determine (a) the spatial extent, direction of transport, and rate of dispersion of EA sediments that were resuspended during cap placement and (b) the extent of onshore transport of suspended materials in the upper layer of the water column and their potential for impacts to nearshore kelp beds. Two types of instruments were used to track and delineate suspended sediment plumes: a Broad Band Acoustic Doppler Current Profiler (BBADCP) (Figure 3-18) and an optical backscatter sensor (OBS) used to measure light transmittance. In addition, two drogues with small surface buoys and flags were deployed in the plume immediately following cap placement (Figure 3-19) for qualitative (visual) plume tracking. One drogue was set at a depth to follow the near-bottom water mass and the second was set at 10-or 15-m depth to follow the near-surface plume (Figure 3-20). The deeper drogue was set 10 m above the bottom to prevent its grounding if the plumes had moved inshore to shallower water (set at 40 m depth in Cell SU and 30 m in Cells LU, LD, and LC). However, current data from the moored instrument arrays and the ship mounted BBADCP indicated that drogues tethered at 30-m depth at the landward cells were effective at tracking the near-bottom flow at these locations, but the 40-m drogue deployed in Cell SU, having a depth of approximately 60 m, was not an accurate indicator of the near-bottom flow. These BBADCP, OBS, and drogue measurements were made in conjunction with collections of discrete water samples discussed in the following section.

BBADCP measurements were conducted using a system operated by ERDC-WES. This system has a five-beam, 600-kHz, BBADCP manufactured by RD Instruments (RDI) in San Diego, CA. The BBADCP was mounted in a hydrodynamically-stable tow body. The BBADCP is towed beneath the wake of the vessel along straight survey lines. During and after the release of the cap material, repeated transects were made to measure the acoustic backscatter from suspended particles which were used to estimate the extent of suspended sediments that resulted from the placement operation.

3.4.5 Water quality sampling

Cap placement has the potential to create a near-bottom plume of resuspended EA sediments mixed with the cap sediment plume. Following each cap placement event, resuspended EA sediment concentrations and associated contaminants were expected to decrease with time due to sediment particle settling and dispersion by near-bottom currents. The purpose of the water quality measurements was to determine the magnitude of total suspended solids (TSS) and total recoverable (i.e., combined dissolved and particulate fractions) p,p'-DDE concentrations in the near-bottom portion of the water column up to 2 hr

after a placement event. The water quality sampling activities were coordinated with the plume mapping task previously described; concurrent measurements were acquired from separate survey vessels. Tracking of the near-surface plume was also done on several occasions to assess the potential for suspended sediment plumes to be transported toward shore and adjacent kelp beds.

The major sampling equipment associated with the water quality sampling survey included a rosette water sampler interfaced with a conductivity-temperature-depth (CTD) water column profiler. The rosette was fitted with 12 10-liter Niskin® sampling bottles for water sample collection (Figure 3-21). The rosette sampler was lowered over the side of the vessel into the plume during the course of the 2-hr tracking effort and water samples were collected by remotely triggering closure of the Niskin® bottles. When the rosette sampler was returned to the deck of the survey vessel subsamples of water were collected from these bottles for TSS and p,p'-DDE analysis.

3.4.6 Surge measurements

The objective of the surge monitoring activity was to use moored, near-bottom current and turbidity sensors to determine the extent (magnitude and duration) of the surge associated with cap placement and how this changed with distance and position (upslope and downslope) (Figure 3-22). These instruments were contained on a bottom deployed quadrapod frame called the Automated Resuspension Surveillance System (ARESS). Up to five similar bottom quadrapods were placed to measure conditions before, during, and after selected cap placement events. These data were collected to evaluate potential for turbidity flows and verify model predictions. Quadrapods were placed on the bottom along a cross-isobath line, and concurrent observations were made to identify the magnitude of the dispersive wave (radially spreading bottom surge) that resulted from cap placement, and document the relative increase in near-bottom suspended sediment concentrations (as inferred from an increase in backscattered light measured by the near-bottom turbidity sensor) due to the initial outward surge as cap material impacted the seafloor.

Near-bottom current velocities and turbidity were measured with sensors attached to the bottom quadrapods at sites located from 60-475 m downslope, and 50-155 m upslope of the respective release site (Figure 3-8). In addition to the near-bottom current measurements on each array, an upward-looking current profiler was also deployed on one of the downslope arrays to monitor horizontal currents throughout the water column.

Current (surge) velocity was measured with three different instrument types, all of which depend on shifts in sound waves (Doppler shifts) in a transmitted acoustic signal. The velocity estimate is proportional to the magnitude of this Doppler shift. The current measuring equipment included:

- a. Acoustic Current Meters (a component of the ARESS measurement platform)

- b. Aquadopp® Current Meters
- c. Acoustic Doppler Current Profiler (ADCP)

Measurements of local near-bottom turbidity were made using OBS. These instruments measured the amount of emitted (infrared) light that was reflected back to the sensor. The material concentration in the volume of water was measured by the amount of light reflected back to the sensor. A time series of measured OBS values provided a history of local TSS in the water column. OBS measurements were made at two levels on each ARESS platform and at one level on each Aquadopp® platform. In each case, data were recorded as part of the current measurement system.

Video documentation of the surge was also collected in conjunction with surge measurements to assess the magnitude and spatial extent of the surge during cap placement. A color video system comprising a video camera, underwater lights, a control console located on deck, and a VCR (video cassette recorder) were used to monitor sediment resuspension and transport (Figure 3-23). The video camera was mounted in a frame that also supported the underwater lights, an underwater compass, and a depth gauge within the camera field of view. During all video-surveying operations, the camera was in a downward looking position. The video camera also was used to conduct transects across portions of the capped cells following various phases of cap construction.

3.4.7 Cap characterization

Several different complementary tools were used to measure the thickness and extent of the cap during the different phases of the operation in order to provide as complete a picture of the cap as possible. This included both point measurements of the cap and continuous surveys along track lines. The combination of these tools allowed mapping of where the cap was located on the seafloor within and beyond the cell boundaries as well as assessment of the mixing between the cap and the EA sediments.

3.4.7.1 Side-scan sonar. Side-scan sonar was used to make 2-D maps of the capping area. This system consisted of a vessel-based data acquisition system connected electronically to a towed device commonly referred to as a towfish which contained acoustic transmitting and receiving circuitry (Figure 3-24). During surveying, the towfish was towed behind the survey vessel while traversing the predetermined survey lanes. Acoustic transducers on the towfish projected acoustic signals outward from both sides to collect data on seafloor characteristics at 90-deg angles from the vessel track. The acoustic beam propagated through the seawater and hit the seafloor. A portion of the acoustic beam that hit the seafloor was reflected backward, with part of the return signal reaching the acoustic receivers of the side-scan sonar towfish. Although acoustic return signals were weak, amplifiers in the side-scan sonar electronics boosted the amplitude of the return signals so that high resolution data on seafloor characteristics (e.g., sand

ripples, minor depressions, rock outcrops) were obtained at considerable distances on both sides of the vessel track.

3.4.7.2 Sub-bottom sediment profiling. Sub-bottom sediment profiling is an acoustic, remote sensing technique for determining relative changes in sediment characteristics in the seafloor (Figure 3-25). The sub-bottom sediment acoustic profiling system was used to acquire high-resolution digital data on the acoustic impedance of seafloor sediments beneath the survey vessel as it traveled along predetermined survey lanes. Acoustic impedance was a function of the density of sedimentary layers and the speed of sound within those layers. The depth of acoustic penetration into the sediments and the ability to resolve sedimentary layering (stratigraphy) from the returned acoustic signals were both dependent on the frequency and pulse-width of the transmitted acoustic signal and the characteristics of the sediments profiled.

3.4.7.3 Sediment profile imaging and plan view photography. The sediment profile imaging (SPI) camera (Figure 3-26) provided vertical cross-section photographs of surface and near-surface sediment on 35 mm slides. Each photographic image provided a 21-cm-high by 15-cm-wide profile of the surface and near-surface sediments. SPI images provided data describing sediment grain size, sedimentary fabric, benthic infauna, and physical and biological processes. One feature measured in the SPI photos was the depth of the Redox Potential Discontinuity (RPD). The RPD, as seen in SPI photos, is defined as the boundary between surface sediments that were oxidized and deeper anoxic sediments. This difference in oxidized and anoxic sediments is visible as a distinct color difference, with the oxidized surface sediments having varying shades of brown, gray, and green compared to the underlying black anoxic sediments. The presence and thickness of this RPD layer was useful for monitoring cap thickness as well as the level of disturbance experienced by the in-place EA sediments. SPI stations were extensively arrayed within and around the cells (Figure 3-7) to carefully map the extent and thickness of the cap material deposits created on the seafloor during the placement process.

The SPI camera was lowered to the seafloor from the survey vessel on a winch wire at the specified survey stations. After the camera frame landed, the camera prism lowered into the seafloor sediments allowing a photograph of the sediment column to be taken through the clear faceplate. The camera was then pulled back into the water column for the next photograph. In these photos the presence and thickness of the cap could be measured. Where the cap became thicker than the penetration ability of the camera, only the presence and minimum cap thickness could be determined.

During monitoring activities, SPI sampling also incorporated a plan view camera (PVC) for underwater photography. This technique generated plan view (downward looking) photographs of the seafloor (covering an area measuring approximately 40 by 60 cm) immediately prior to penetration of the SPI prism. These data complemented the SPI data by documenting surficial features on the seafloor in the vicinity of the profile image. These photographs were also useful for mapping the extent of the cap as the presence of shell, different colored

sediment, and infilling and covering of organism burrows were all indications of cap presence.

3.4.7.4 Sediment coring. Sediment coring equipment (Figure 3-27) was used to collect vertical samples from the sediment column to measure baseline conditions, as well as changes to the sediment column that occurred during capping. In particular, coring was used to measure cap thickness, especially once cap thickness exceeded that measurable by the SPI camera. A conventional gravity corer was used in the baseline and summer portions of the field program, and sealed core samples were transported to shore for postsurvey processing and analysis. Analyses included photography and visual description of all cores, as well as subsampling for selected geotechnical and chemical analyses from discrete intervals within the cores. Core sampling was conducted several months after the completion of the pilot study cells in a February 2001 survey in an attempt to get more complete measurements of cap thickness than had been obtained using the gravity corer in the summer 2000 effort. This coring used both a vibracore and a box core to sample the sediments. As discussed in the following sections, core samples appeared to be frequently affected by mixing caused by the coring process itself. This tended to limit, somewhat, the conclusions that could be based on these samples.

3.5 Baseline Monitoring Results

Coring results

Baseline monitoring of the pilot study capping cells provided data that were consistent with the previous descriptions of the Palos Verdes Shelf conditions (Lee 1994). Sediments were about 58 percent sand and 42 percent silt/clay in Cell LU and 49 percent sand and 51 percent silt/clay in LD (Figure 3-28). Coarse materials such as gravel or shell materials were rare or nonexistent. The seaward cells had substantially less sand and greater amounts of silt and clay. In the SU and SD 0-4-cm core sections, sand comprised about 22 percent by weight (Figure 3-29). Sand content decreased with depth down core such that it accounted for only 10 percent of the composition in the 16-20-cm core sections. Silt in these same cores remained nearly constant down core at about 51 percent while clay comprised about 24 percent in the 0-4-cm fraction and increased steadily to 35 percent in SD and 40 percent in SU.

Baseline measurements of p,p'DDE indicated that the surface contaminant concentrations in the seaward cells were substantially higher than those in the landward cells (Figures 3-30 and 3-31). Surface concentrations in the landward cells ranged from about 0.75 to 2.2 mg/kg p,p'DDE. Cells SU and SD had a similar lower range, but surface concentrations in cell SD were as high as 8.5 mg/kg and in SU they were as high as 12 mg/kg.

Down-core concentrations of p,p'DDE were also different between the landward and seaward cells. There was very little change in concentration with

depth in Cells LU and LD, consistent with earlier sampling by USGS at their station located closest to these cells (Figures 3-32 and 3-30). Cells SU and SD showed increases in p,p'DDE concentration with depth in the most seaward cores (C3, C4, C7 and C8), especially below 12 cm where 40 to 100 mg/kg concentrations were often measured (Figure 3-33). However, stations located shoreward in Cells LU and LD (C1, C2, C5, C6, and C9) were similar to those collected in Cells SU and SD. The USGS station closest to Cells LU and LD (Figure 3-30) also exhibited a subsurface peak, though increases with depth similar to those measured during the baseline monitoring did not occur until at least more than 35 cm into the sediment (data not shown).

There is some possibility that coring artifacts may have influenced these observations. It is suspected that a bow wave created by the gravity corer during its descent through the water column and the relatively soft condition of the top few centimeters of the sediment may have caused the corer to under sample the surface layers of sediment. This under sampling may have been even more pronounced in the seaward cells which had lower bulk densities and lower sand contents. Thus, all descriptions of sediment conditions based on core depth may actually be reported as shallower than truly existed in the sediment deposit.

The sediments were classified as clayey silty sands in the landward cells and clayey sandy silts in the seaward cells. Bulk density in the landward cells was 1.76 g/cc, greater than that of the seaward cells at 1.4 g/cc (Table 3-3). The landward cells had low liquid and plastic limits between 30 and 42 percent, indicative of the high sand contents of these sediments. The seaward cells had a much broader plasticity range consistent with the greater presence of silt and clays in these sediments.

Sediment profile and plan view results

The cells were found to have a very well developed benthic infauna. Both the SPI and PVC cameras provided consistent observations of abundant benthic infaunal burrows, tubes, and direct photos of organisms. However, the sediment profile camera survey did reveal some differences between landward cells LU and LD and the deeper seaward Cell SU. The seaward cells had much less biogenically produced microtopography. Average boundary roughness values (a measure of the variation in small-scale elevation changes across the width of the photo) in SPI photos were 1.6 and 1.5 cm for Cells LU and LD, respectively. This was indicative of the abundant sediment mounds or depressions that the camera prism would slice through. The seaward Cell SU, had a lower average boundary roughness value of 1.2 cm. In this cell the seafloor usually appeared as a flat line or gentle slope across the SPI camera view (Figure 3-34). The observation of less seafloor micro-topography was supported by reviewing the plan view photos, which suggested a much greater abundance of burrow openings, pits, and mounds in the landward cells compared to the seaward cell. The Redox Potential Discontinuity (RPD) values (a measure of oxygen penetration into the sediment) were generally similar among the landward and seaward cells, with the mean between 2.5 and 2.8 cm.

Seafloor characterization

The baseline sub-bottom sediment survey was conducted in mid-May 2000 (Figure 3-35). The interpretation of the sub-bottom data for this survey showed a distinct and well-defined surface layer with indications of a probable bedrock layer located approximately 8-16 m below the main seafloor surface layer (Figure 3-36). Sub-bottom sediment lines N and O clearly showed the sewer diffuser pipe above the seafloor surface. In addition, a relatively fine surficial layer of sediment was also distinguished upon close examination of the seafloor interface layer. This thin, surficial layer is thought to represent the effluent-affected sediment with the ambient sediment below (Hampton 1994).

The baseline side-scan sonar results showed a relatively uniform and undisturbed seafloor with no prominent differences and few distinguishing features (Figure 3-37). The LACSD sewer outfall was evident in the southeastern portion of the survey area and a small, rectangular feature (11 m long) was detected in the inshore portion of the southern, cross-slope survey lane.

Water quality results

DDE concentrations measured in the water column near the seafloor prior to placement events in Cells LU and SU ranged from 0.006-0.02 ug/L (6-20 ng/L). Results for baseline conditions prior to surveys at Cells LD and LC were of a similar magnitude averaging 0.0066 and 0.0048 ug/L, respectively. Total suspended sediment levels in these near-bottom baseline samples averaged 2 mg/L in the area of each of the cells.

3.6 Construction Monitoring Results

Results from monitoring during construction of the caps is discussed in three separate sections. The first section discusses the characteristics of the cap sediments as they were measured from samples collected on the dredge. The second section discusses the observations made of the development of the caps over the EA sediment in the individual cells. The third section discusses the monitoring of the short-term water column processes of the capping placement events: the near-bottom current surges and tracking of the ensuing sediment plumes.

3.6.1 In-hopper cap material characterization

The cap material hopper samples of the Queen's Gate sediment were comprised of approximately 80 percent sand, greater than the 22-50 percent sand of the EA sediments (Figure 3-38). The A-III borrow site hopper samples were even sandier than those from Queen's Gate (98 percent sand), and they were also comprised of even larger diameter sand sizes than the Queen's Gate samples (Figure 3-39). Both cap materials were dominated by sediment in the

0.125-mm-diam size class (fine sand). The next most abundant fraction in the Queen's Gate material was the 0.0625-mm-diam size class (very fine sand), while the next most abundant fraction in the A-III borrow site sediments was the 0.25-mm size class (medium sand).

Comparing the cap hopper samples to baseline data (within the depth range of 0-4 cm) from each of the individual cells showed there was a broad overlap in the grain size distributions of the cap and EA sediments, but the capping sediments had larger sand grain sizes that were present in very low percentages in the EA sediments. EA sediments in Cell LU were dominated (53 percent) by sand of 0.0625-mm-diam, with a very small percentage of grains sized between 0.125-mm and 0.25-mm (3 and 1 percent, respectively) (Figure 3-40). The Queen's Gate sediments also had a high percentage (33 percent) of 0.0625-mm-diam sand, but the 0.125-mm class represented 36 percent of the composition and the 0.25-mm class was 9 percent. These differences between cap and EA sediments were even more dramatic for Cells SU and LD (Figures 3-41 and 3-42).

DDE concentrations in the cap materials were low, occurring at levels that were three to five orders of magnitude lower than the concentrations in the surface sediments of the pilot study cells. Based on in-place core samples from the Queen's Gate channel, it was estimated that the sediment used during the pilot study capping project had a maximum of 0.02 mg/kg DDE. Three DDE analyses were conducted on hopper samples following dredging of the A-III borrow site sediments. DDE concentrations in these sediments averaged 0.0018 mg/kg DDE.

3.6.2 Cap construction

3.6.2.1 Conventional placements in Cell LU. Placement of Queen's Gate cap material in Cell LU involved 71 loads of sediment, totaling approximately 69,800 cu m (estimated in source volume, approximately equal to the hopper settled solids volume). The first five loads were placed in the center of the cell (Figure 3-43). Once these loads were on the seafloor, subsequent placement always was done so that each new load occurred over the existing cap so as to minimize the disturbance to the EA sediments. Capping loads 6-25 took place over the central portion (center 300 x 300-m area) of the cell, loads 26-45 were placed along the outer edges to achieve complete cell coverage, and loads 46-71 were directed to the central half of the cell with the objective of creating a cap 30-45 cm thick there.

Initial monitoring - load 1.

The placement of the first load of cap near the center of Cell LU (Figure 3-43) resulted in a sediment deposit which was a very reasonable match to numerical modeling predictions (see Chapter 4 for further discussion). The cap was visible in sediment profile photographs as a distinct, continuous layer composed primarily of gray-colored, fine sand (Figure 3-44). The overall deposit, measured using SPI photos, was about 200-250 m in diameter. The central portion of this deposit, within a 50-m diameter, averaged 5 cm thick.

From there the deposit thinned out onto the flanks. The center of the deposit was also characterized by the presence of mud clasts and large pieces of shell, and there was strong visual evidence from the thickness of the RPD layer below the cap that at least the top few centimeters of the EA deposit had been disturbed by and likely mixed into the cap material. Thus, the observed cap thickness was likely a mixture of cap sediments and EA sediments. This understanding is especially important in interpreting the early phases of capping when comparing to model results. Farther out on the deposit (125-200 m from the placement point) where the capping sediment had arrived by lateral transport, the disturbance of the EA deposit was notably minimal or absent as the RPD layer was still largely intact. Beyond the margins of the cap sediments, no disturbance of the EA sediment was evident as the thickness of the precapping RPD at these stations was unchanged.

Plan view photography and side-scan sonar provided confirming results. The plan view photos showed the presence of shell fragments on the surface and also burrow depressions were draped with a new layer of sediment (Figure 3-45). Shell fragments provided a very good diagnostic feature of the cap material as they were seldom present in the baseline sampling. However, shell fragments were not always present when cap was clearly present at SPI stations, and there were also stations that showed no evidence of sandy cap materials though shell fragments were present. At these latter stations it is hypothesized that the shell had a different settling trajectory because of a kiting behavior where the flat shell fragments moved laterally through the water column in addition to downward settlement.

The side-scan sonar data following this single placement showed a change in seafloor features that correlated well with the SPI cap distribution data and the ADISS data on cap release position (Figure 3-46). The most intense side-scan sonar signal return (darkest) corresponded to the portion of the deposit measured as greater than 4 cm thick by SPI. Interpretation of the side-scan sonar was also able to detect seafloor changes that corresponded to the SPI 2-cm contour, but beyond this, side-scan sonar was not able to distinguish cap material from ambient EA sediments. There was also no evidence of any downslope sediment disturbance (e.g., erosion channels) due to turbidity currents. This helped to confirm the observations made in the SPI and plan view photos that the downslope sediments were unaffected by the placement of the cap.

Visual estimates of cap thickness from the cores were complicated by the similarity in the coloration of the sediments in the cores and by coring artifacts, including possible bow wake loss of cap during core penetration and mixing of cap by the coring device. This made visual comparisons to the SPI data somewhat tenuous.

At two of the five core sampling stations, cap was observed in the corresponding SPI images after the initial placement event. At one of these stations, the visual core estimate of cap thickness was 3 cm compared to an SPI estimate of 4.3 cm. At the other station, the cap was not visually observed in the core, whereas the SPI detected 5 cm of cap. For the other three stations, the SPI

results indicated that cap was not present and it was also not observed in the cores.

Interim monitoring - loads 2-5.

The next four placement events, again near the center of the cell (Figure 3-43), created a thin cap over the majority of the 300 x 600-m cell (Figure 3-47). Cap thickness exceeding 5 cm covered an area with a diameter of 150-175 m in the central portion of the cell. At a minimum, the cap was 8-10 cm thick at the innermost stations where the camera was not able to penetrate farther into the sediment. The entire center half of the cell was now covered with at least 2 cm or more of cap. Plan view photography helped to confirm the cap distribution, though it was not able to document the distribution as definitively as the SPI photos (Figure 3-48). Visual estimates of cap thickness from cores provided only modest agreement with the SPI results.

Side-scan sonar data following the five placement events did not correlate with the SPI contours as well as after the first event (Figure 3-49). The center of the cell clearly showed evidence of cap placement, but because the lateral surge tended to leave a smooth featureless seafloor it was difficult to detect cap distribution with the side-scan sonar system beyond this immediate placement position.

Interim monitoring - loads 6-25.

Twenty additional capping loads distributed over the cell resulted in total cap coverage that ranged from a minimum of 8-11 cm, based on the sediment profile photographs (Figure 3-50). Actual cap thickness could not be determined because of the inability of the camera to penetrate farther into the sandy cap sediment. At this stage in the capping, the range of variability in cap thickness among station replicates was generally about 2 cm, but at two stations within the cell the intrastation range was somewhat greater, on the order of 4-5 cm. Good agreement in cap distribution was found between the plan view and the SPI results from this survey, though as called for in the monitoring plan at this stage, none of the sampling extended off of the cap apron. Poor to good agreement in cap thickness was found between the nine cores that were co-located with SPI stations.

Side-scan sonar data were not able to provide any increased understanding of the lateral cap distribution beyond that found with SPI. The data do help to better understand the cap development process, however, as they clearly show the most recent placement events. In contrast, older placement events in the center of the cell were no longer evident, because the lateral surge from nearby, subsequent events laid down a smooth surface over the rougher impact areas that distinguished them (Figure 3-51). It was this combination of multiple placement positions and lateral surge that resulted in the accumulation of small overlapping incremental layers leading to a uniform cap distribution and thickness.

Interim monitoring - loads 26-45.

Forty-five loads of sediment resulted in more than 95 percent of Cell LU being covered with a minimum of 10 cm of cap (Figure 3-52). Within the cell the cap was generally greater than the SPI penetration depth. Cap up to 5 cm thick extended 100-150 m beyond the cell boundary in all directions. Again, side-scan sonar detected the most recent placement events, including thin trails of sediment that were released as the dredge was closing its doors and heading back to the dredging site (Figure 3-53).

Visual core results again provided mixed results in comparison to the SPI. At three stations where SPI results found cap of at least 9-12 cm, the visual core observation was not able to discern any. At three other stations where the SPI observed a minimum of 10-12 cm, the cores suggested only 3-5 cm. However, at the remaining three stations the coring was able to detect cap thicker than that observable with the SPI. These results underscore the challenge that was presented by the visual description portion of the coring monitoring effort. Similarity of the EA sediments and cap, along with probable but only semi-quantifiable sediment disturbance artifacts associated with the core penetration greatly complicate and limit the interpretation based on this technique alone.

Core chemistry, however, provided evidence to support a cap thickness containing little to no EA sediment on the order of 12-16 cm in the central portion (middle 300 x 300-m area) of the cell with perhaps a thinner and more mixed condition further away (Figure 3-54). Total cap thickness in the central portion of the cell, including the mixed zone, appeared to be on the order of 12-20 cm. The two cores collected near the center of the cell (Cores 55 and 56) had levels of DDE less than or similar to the Queen's Gate sediment concentrations (0.1 mg/kg) from the top of the cores to the 8-12-cm core intervals. Core 52, located in the southwest corner of the cell, exhibited a similar DDE distribution. In contrast, Core 57 (located in the northwestern end of the cell where SPI suggested as much as 10 cm of cap) had DDE concentrations in the 0-4 cm section that were similar to baseline concentrations (Figure 3-54). Coring artifacts as previously discussed may also have resulted in an underestimate of cap thickness.

Final monitoring - loads 46-71.

Placement of 71 loads of cap sediments created total cap coverage over Cell LU with a minimum thickness of 12 cm. A thicker cap, which was estimated at about 16 cm thick, was present over the central third of the cell where a greater volume of sediments had been sent. Total cap spread extended between 100 and 200 m beyond the cell boundary. Side-scan sonar did not detect any evidence of down slope sediment disturbance (e.g., turbidity flow-related erosion channels).

Core chemistry suggests that a relatively clean (i.e., insignificantly impacted by DDE contamination associated with EA sediment) cap material layer of at least 12-16 cm was present over the central portion of the cell (Figure 3-54). Below this, a mixed zone of about 4 cm was present resulting in an estimated cap

thickness of 16-20 cm over the central portion of the cell. Chemistry data from three cores (Cores 60, 61, and 64) all showed DDE levels less than or similar to Queen's Gate cap sediment levels from the top of the core to the 8-12-cm interval (Figure 3-54). Core 61 suggested an even thicker cap with the low concentrations persisting down to 16 cm. Considering the potential loss of cap from a bow wake during coring, this suggests that the actual in-place cap thickness may have been as much as 6-8 cm greater.

The side-scan sonar survey was conducted before all 71 loads of cap were placed, between load 68 and 69. Again, as discussed earlier, the side-scan sonar data documented where the most recent loads of cap were placed and also detected several dredge departure trails (Figure 3-55).

3.6.2.2 Conventional placements in Cell SU. Placement of Queen's Gate cap in Cell SU involved 21 sediment loads, totaling approximately 22,800 cu m (estimated hopper volume). The first five loads were placed in the center of the cell (Figure 3-56). Each new load subsequently was placed over the in-place cap material so as to minimize the disturbance to the EA sediments. Capping loads 6-21 took place over the central portion (middle 300 x 300 m) of the cell with the objective of creating a cap 10-15 cm thick in this location.

Initial monitoring - load 1.

The first cap load in Cell SU created a circular deposit about 275-325 m in diameter (Figure 3-57). The central portion of this deposit, within a 50-m diameter, averaged 5 cm thick. From there the deposit thinned out onto the flanks. Disturbance of the EA sediment from cap placement, based on the partial removal or absence of the former RPD zones, was most noticeable at stations near the center of the deposit. Here the disturbance was estimated at 1 to 2.5 cm, the thickness of the former RPD at these stations. Farther out from the center (125-200 m), the disturbance of the EA sediment decreased and was not evident beyond the footprint of the cap.

The side-scan sonar data following this single placement showed a change in seafloor features that correlated well with the SPI cap distribution data and the ADISS data on cap release position (Figure 3-58). The most intense side-scan sonar signal return (darkest) corresponded to the portion of the deposit measured as greater than 4 cm thick by SPI. Interpretation of the side-scan sonar was also able to detect seafloor changes that corresponded to the SPI 3-cm contour, but beyond this, side-scan sonar was not able to distinguish cap material from ambient EA sediments. There was also no evidence of any downslope sediment disturbance (e.g., erosion channels) due to turbidity currents.

The plan view and side-scan sonar data supported the SPI characterization of the deposit. The plan view photographic evidence, particularly the presence of shell hash, was similar to, but somewhat less extensive than the SPI footprint. No cap material layers were observed in any of the visual descriptions from the five cores that were collected. However, four of these cores were collected at stations where the corresponding SPI cap thickness was relatively thin, ranging only from 0 to 2 cm. Only one of these cores, SUHO9, was collected where the

cap material layer observed in the corresponding SPI images was comparatively thick, averaging 6 cm.

Interim monitoring - loads 2-5.

The next four placement events, again near the center of the cell, created a thin cap over the majority of the 300 x 600-m cell (Figure 3-59). Cap thickness exceeding 5 cm covered an area with a diameter of 200-250 m in the central portion of the cell. At a minimum, the cap was 8-10 cm thick at the innermost stations where the SPI camera was not able to penetrate farther into the sediment. The entire center half of the cell (300 x 300-m area) was now covered with at least 2 cm or more of cap. Plan view photography provided good confirmation of cap distribution, but was not able to detect the presence of cap layers beyond where SPI detected 3 cm or less. Core visual determinations provided relatively poor agreement with the SPI cap thickness estimates.

Similar to what was observed in Cell LU, side-scan sonar data following the five placement events did not correlate with the SPI contours as well as after the first event (Figure 3-60). However, in this cell a radial surge pattern was evident around the central feature. This radial pattern extended about 175 m from the placement area downslope and about 100 m upslope. The presence of this asymmetrical surge pattern in Cell SU but not in Cell LU may be related to differences in sediment composition, depth, slope, or a combination of all of these.

Final monitoring - loads 6-21.

Twenty-one capping loads at Cell SU produced a cap that covered virtually all but a small area of the cell (Figure 3-61). The central portion (300 x 300-m area) of the cell had a minimum of 6-11 cm of cap with the exception of the northeastern portion of the cell where one station had 5-8 cm and the other 2.5 cm. Again, total measurement of cap thickness was limited by penetration of the SPI camera into the sandy cap. One station within the southeastern portion of the cell exhibited no cap, but the remaining outer portions of the cell had from about 1 to 6 cm of cap. Cap thickness exceeding 5 cm covered an area with a diameter of about 450 m (Figure 3-61). Again, it was observed that disturbance of the EA sediments from the capping operation, based on RPD thickness, decreased with distance from the actual capping operations. Side-scan sonar provided no additional data to delineate cap placement, but again the data did document the absence of any evidence of seafloor erosion due to creation of turbidity currents from the cap placement activities.

The plan view camera cap distribution provided very good confirmation of the SPI results. In this survey the plan view camera was able to confirm cap presence out to where SPI estimates were between 2 and 3 cm. Concordance of the coring cap thickness estimates with the SPI estimates ranged from poor at one station to very good at the remainder. In four of the comparisons the core samples suggested that the cap was thicker than could be determined with the SPI camera.

Chemistry results were available from two cores in the central portion of the cell (46 and 47) and two located nearer the periphery (45 and 49). The two central cores both showed cap from 0-4 cm that appeared to be unimpacted by mixing and core 47 had somewhat mixed concentrations in the 4-8 cm interval (Figure 3-62). The peripheral cores did not show any evidence of cap based on the chemistry. However, as has been discussed before, the coring was believed to provide an underestimate of cap thickness based on its comparison to the other data (e.g., SPI) and field observations made during collection of the cores.

3.6.2.3 Spreading placements in Cell LD. In Cell LD, nine loads of sediment from the A-III borrow site, totaling approximately 10,300 cu m, were placed using the spreading mode. All loads were placed with the dredge slowly releasing material as it moved along the central axis of the cell (Figure 3-63). This placement on the same lane was done so that each new load occurred over cap that was already in place, thereby minimizing disturbance to the EA sediments. The spreading placement was done with the objective of creating a thin cap and providing a comparison to the cap creation observations of the conventionally placed material.

Initial monitoring - load 1.

The first load of cap sand in Cell LD was placed on a lane down the central axis of the cell, while the dredge was moving slowly forward at a speed of approximately 2 knots. About 75 percent of the sediment was released along the first half of the lane, although placement continued beyond the cell boundary to the northwest (Figure 3-64). This resulted in a cap ranging from 1-3 cm in thickness along the track (Figure 3-65) with an average thickness of 1.5 to 2 cm. The cap extended out towards the edges of the cell with coverage 0.5 to 1 cm thick. The cap itself was composed of golden sand that was clearly distinguishable from the EA sediments (Figure 3-66). The RPD of the EA sediment below the cap generally showed less than 2 cm of disturbance from the impact of the descending sand, which is in contrast to the greater disturbance observed in the conventional placement cells. Somewhat greater disturbance was noted at two stations closest to where the thickest cap was placed. Plan view photography provided good confirmation of cap distribution. Core visual observations did not detect any cap, presumably because of coring artifacts as previously discussed.

Side-scan sonar detected a linear feature down the axis of the cell and two radial features about 100 m in diameter correlating with the 2-cm-thick cap areas (Figure 3-67). Even though the cap placement technique of spreading would tend to produce less seafloor disturbance than the conventional placement used in cells LU and SU, the A-III borrow sediments had an acoustic signature that was sufficiently distinct from the PV shelf sediments to enable better discrimination of the two in the records.

Final monitoring - loads 2-9.

Cell LD was completely covered with cap sediments ranging from a minimum of 1 cm to more than 10 cm thick at the end of nine capping events

(Figure 3-68). Along the central cell axis the cap was generally 6-10 cm thick or more. The only exception to this was a station at the end of the lane that had only 3-4 cm of cap. This was consistent with the records of hopper draft placement which showed most of the sediment was released before the end of the lane was reached. Cap extended to and beyond the margins of the cell. Stations along the inner edge of the cell had from 1-5 cm of cap. Stations just beyond the long axis cell edges had about 1-2 cm of cap. Plan view photography provided generally good agreement with cap distribution, though there were some stations where cap was detected with SPI and not with the plan view camera. No cores were collected for comparison.

As was observed following the initial cap load, there was little to no disturbance of the underlying EA sediment. This was evident from the persistence of the precapping oxidized surface layer (RPD) and the presence of feeding voids below the distinctive capping layer.

Side-scan sonar again was able to provide relatively good identification of where the cap sediments had been placed (Figure 3-69), but only out to about the SPI 6-cm contour. Unlike the Queen's Gate sediments, the A-III sediments produced a weaker (lighter) return, which allowed them to be distinguished from the EA sediments. Where the cap was thinner, the underlying EA sediment may have influenced the acoustic return such that there was insufficient contrast to appear in the data records.

3.6.2.4 Hopper pumpout placement in Cell LD & LC. A trial was conducted using the dredge to place sediments very gradually by pumping the sediments back out through the drag arm. Placement involved only one partial load of 300 cu m of Queen's Gate sediment placed down the axis of Cells LC and LD. The load was placed with the dredge slowly releasing material with the drag arm lowered about 24 m below the water's surface. This trial was conducted following the placement of the nine loads of A-III borrow site sediments in Cell LD.

The primary purpose of this trial was to test the feasibility of placing cap using this alternative to provide a means of reducing seafloor impact potential even further than with the spreading placement alternative. The trial demonstrated that pumpout could be successfully accomplished by the hopper dredge, though for a full-scale operation modifications to the dredge's piping would likely be required.

Surveys using the SPI and PV cameras following this single load detected the presence of the cap as thin (< 1 cm) discontinuous deposits of sediment, presence of clay clasts, and pieces of shell hash (Figures 3-70 and 3-71). Both techniques detected cap material at all stations along the axis of the cell which the dredge traveled. At outlying stations the detection of cap by the two techniques was not always coincidental.

3.7 Cap Placement Monitoring Results

3.7.1 Surge monitoring

Seven individual placement events were monitored using the upslope and downslope bottom-mounted instrumentation arrays (Table 3-4): five in LU, and one each in SU and LD. Deployments varied somewhat from time to time depending on equipment availability (Figure 3-8) (Table 3-5). Actual distances of the arrays from the placement events were a function of the position of the dredge during release of the sediments (Table 3-5) and the actual data return was sometimes affected by equipment loss or battery life (Table 3-6). Additionally, the “150 m” SU upslope array (Table 3-5) was unintentionally snagged and towed to a location 475 m downslope before the placement event, then fortuitously recovered 20 months later with useable data (Table 3-6). Overall the data provide a good assessment of surge conditions during cap placement events.

Current speed (1.25 m above bottom, 12-sec average) and turbidity were observed to steadily decrease with distance from the cap placement location during all monitored events as the radially spreading surge mixed with ambient water and lost momentum (Figures 3-72 and 3-73). In Cell LU the downslope arrays at 75 m observed maximum current speeds in the 70-120 cm/sec range, the 150-m downslope array observed maximum speeds of 33-57 cm/sec, and the downslope 250-m array observed maximum speeds of 16-25 cm/sec (Figure 3-72). All horizontal momentum may have been lost at a distance of 350 m from the release point at the center of the cell. Similarly, the maximum near-bottom turbidity (measured in standard units of Formazin turbidity units (FTU)) at the same arrays went from 400-660 FTU to 305-490 FTU to 75-200 FTU.

Decrease in surge velocity appeared to be less at the more steeply sloped Cell SU, though the reduction in maximum speed from the 115-m array (72 cm/sec) to the 170-m (63 cm/sec) array was 12 percent over the 55 m separating the two meters. The meter that accidentally ended up at 475 m downslope recorded a maximum speed of 29 cm/sec. This demonstrated a steadily decaying presence of the surge with time. Maximum turbidity in the single event at SU showed very little change in maximum value between the first two downslope arrays, but the maximum value had decreased by about 50 percent at the 475-m array.

Current velocities during the spreading event in Cell LD were notably less than those observed in either Cell LU or SU. Again steady decay of the velocity was observed with the 250-m array observing a maximum current speed about 43 percent lower than observed at the 75-m array. Turbidity values were considerably less, which may be partially a result of the lower quantity of fines present in the A-III sediments compared to the Queen’s Gate sediment, but also a consequence of less disturbance to the EA sediment from the placement process.

At any given point, the surge was a relatively short-lived phenomena, peaking quickly and then steadily decreasing to baseline typically within 12 min

at the 75-m arrays and even less time at the 150-m arrays. This surge duration can be observed in the time series records of current speed, turbidity, and current direction at Cell SU (Figure 3-74). The decreasing duration of the surge again supports the belief that placement of cap is unlikely to result in creation of turbidity currents.

With one exception, discussed in the following paragraphs, the current speeds were equal to or lower at the upslope arrays than at similarly placed downslope arrays. While there are only four direct comparisons of current speed, a fifth comparison can be estimated for Cell LU, event 5 which also supports the overall trend. This can be done by analyzing the percent decrease from the 75-m arrays to the 150-m arrays for Cell LU, which ranges from a 52-70 percent reduction in current speed. Using the 52 percent reduction as a conservative estimate, we can estimate the current speed at 75 m by dividing the 50 cm/sec observed at the 150-m array by 48 percent. This results in an estimate of 104 cm/sec at 75 m downslope compared to the actual measured value of 85 cm/sec at the upslope meter.

The one exception to the upslope/downslope trend occurred for LU event 2 where the upslope current was substantially greater than the downslope current at 75 m. In this case, cap placement actually occurred much closer to the upslope array than the downslope array, resulting in the greater speed observed at the upslope array relative to the one placed downslope.

For Cells LU and SU, turbidity at the 75-m upslope/downslope paired arrays was consistently less at the upslope array, even for the one event where current speeds were observed to be greater. Similarly as was done for currents, we can estimate what the turbidity value for event 5 in Cell LU might have been by using the most conservative reduction observed in the other data. This results in an estimate of 429 FTU at the downslope array which is greater than the observed upslope array value of 395 FTU.

Near-bottom turbidity within the surge during the spreading event in Cell LD did not show the upslope/downslope asymmetry that was observed during the conventional events in Cells LU and SU. More importantly, turbidity during the single spreading event monitored was much less than that encountered during the conventional placement events.

3.7.2 Near-bottom plume tracking

Plumes created by the cap placement process (regardless of depth tracked) predominantly moved in an alongshore (NE, SW) direction. Near-surface and near-bottom drogues provided good results on flow directions during flood and ebb tidal phases (Figure 3-75). In those few instances where plume movement was in an on-shore direction, it did so weakly such that the plume traveled less than 200 m from the cell during the approximate 2 hr of observation. In contrast, alongshore excursions were often between 1-2 km during the 2-hr tracking time. These observations covered a range of tide conditions and were also consistent with the current meter data from the bottom-mounted arrays which observed that

whenever sustained currents were moving in a shoreward direction they were no more than 10-20 cm/sec.

Suspended sediment levels in the centroid of the near-bottom plume were initially high (350-3,400 mg/L) and by the end of the approximately 2-hr monitoring period, levels had decreased to 5-20 mg/L, as compared to baseline concentrations which were approximately 2 mg/L (Figure 3-76).

DDE concentrations (total water column value which included both dissolved and particulate) were similarly greatest at the inception of the plume (0.1-1.2 ug/L) and decreased within 1-2 hr to below baseline levels (0.006-0.02 ug/L) (Figure 3-76). The highest DDE concentrations were also observed during the first placement event to occur in the cells, whereas subsequent placement events began with much lower DDE concentrations. This observation gives strength to the management approach used to minimize disturbance of the EA sediments by never placing cap directly on the EA sediment after the initial load.

3.7.3 Near-surface plume tracking

Plume monitoring observations indicate that there is a very low risk of unacceptable quantities of suspended sediments being transported to the kelp beds located approximately 1,000 m closer to shore. The results from monitoring of shallow plumes (surface to 10-m depth) were consistent with the alongshore transport observations of the deeper plumes (20-40 m) conducted to assess EA sediment resuspension (Figure 3-77). While some of the deeper plume tracking surveys did detect onshore movement, the results for the near-surface plumes showed no more than a 200-m shoreward transport during the measurement period (s). Further, this shoreward transport was usually observed around the time of slack water such that any shoreward movement would likely be quickly overwhelmed by the stronger alongshore ebb and flood currents. Light transmission and suspended solids levels reached or approached baseline during the 2-hr duration of all three surveys (Figure 3-78). In particular, the A-III sand sediments produced very little detectable presence of suspended sediment in the water column and caused very little change in the light transmission characteristics of the water.

3.8 Postconstruction Monitoring Results

Cell LU

The results of the supplemental SPI sampling at Cell LU performed in February/March 2001, roughly 5 months following the creation of the cap material deposits, generally showed that cap material layers at selected stations remained present and were approximately the same thickness as observed in the immediate postcap (post-71) monitoring. These results suggest there was no

significant change in the lateral spread of material on the seafloor at 5 months postcapping.

SPI images for the supplemental survey also indicated the presence of a visually distinct surface layer of fine-grained sediments on top of the intact cap layer. This surface layer varied in thickness from 2 to 8 cm, and comprised sediments that were finer grained than cap material. Thus, it is likely that this layer consisted of EA sediments that were possibly transported from adjacent areas outside the cell and/or that were transported through the cap by bioturbating organisms.

Due to sampling artifacts associated with the supplemental survey vibracoring (i.e., drag down or wash down of surface material along the inside of the core liner), the ability to determine sediment layering and the contributions of the recently deposited EA sediment to measured DDE concentrations could not be determined quantitatively. As a result, the supplemental survey data are considered of limited use for evaluating the cap thickness and contaminant distribution.

Box cores collected during the supplemental survey appeared to have fewer artifacts, and more representative stratigraphies, than those collected by the vibracores. However, the small box core used during the supplemental survey could not consistently penetrate the cap/EA sediment interface. In total, the chemistry and geotechnical results obtained from vibracores could not be used to accurately determine the actual thickness of the cap layer or spatial variability in cap thickness.

Cell SU

During the supplemental survey in February/March 2001, SPI sampling in the vicinity of Cell SU occurred primarily outside (upslope) of the cell boundary. Cap layer thickness values (2.3 to 8.5 cm) obtained at these sites were slightly less than those obtained immediately following (Post-21) cap placement (3 to 9.3 cm), with the exception of one site that had a 3-cm-thick cap layer during Post-21 but no detectable cap during the supplemental survey. These differences between surveys in cap layer thickness could be due to loss of small amounts of cap material by erosion or consolidation, or spatial variability in cap thickness. However, the presence of a layer of newly-deposited, fine-grained sediment, with thicknesses ranging from 1 to 4.7 cm, suggests that erosion effects in the vicinity of Cell SU were negligible during the time between the Post-21 and supplemental surveys. As discussed for Cell LU this new sediment layer likely consisted of EA sediments that were transported from adjacent areas outside the cell and/or that were transported through the cap by bioturbating organisms. Evidence of cap material in the vibracore samples collected during the supplemental survey was equivocal because of the coring artifacts, as discussed for Cell LU. One of these cores had DDE levels in the top sediment layer exceeding 100 mg/kg which may have been due to coring artifacts or possibly a local disturbance of the seafloor (e.g., trawl impacts, anchor drag, etc.).

Cell LD

The Cell LD SPI results from the supplemental survey indicated the presence of a visually distinct cap material layer having thicknesses (5.3 to >8.5 cm) consistent with those measured during the Post-9 survey in September 2000. SPI images for the supplemental survey also indicated the presence of a 6-cm surface layer of new sediment which likely consisted of EA sediments that were transported from adjacent areas outside the cell and/or that were transported through the cap by bioturbating organisms. Because the cap within Cell LD was spread along a line and resulted in less areal coverage than the cap within Cells LU and SU, it is more likely that EA sediment was transported laterally onto the cap of Cell LD than in Cells LU and SU. Indications of sampling artifacts suggest that the results of the supplemental coring survey did not provide an accurate measurement of cap layer thickness for Cell LD.

3.9 Assessment of Results Relative to Key Questions

At the outset of the pilot study, and reiterated at the beginning of this chapter, several key questions were identified that would be used to evaluate the success of the capping of EA sediments on the Palos Verdes Shelf. A summary follows of how we view the results, relative to the first four original questions. The fifth question on modeling is addressed in Chapter 4. In addition, for discussion purposes, each of the four questions are broken down into a few subquestions that are enclosed in text boxes.

3.9.1 Can a uniform cap be constructed?

Evidence from the sediment profile, coring, and side-scan sonar surveys all support a conclusion that it will be possible to create a uniform cap on the Palos Verdes Shelf. The caps that were created using both conventional and spreading placement generally varied in thickness by only a few centimeters across those areas that received what could be considered a full cap application during the pilot study, namely, the central portion of Cells LU and SU and the central axis of Cell LD. It does appear though, that the use of spreading placement may result in a cap that has somewhat greater uniformity than one created with conventional placement.

The cap placement spacing, which was based on modeling and the results of the initial field surveys, appeared to be reasonable for helping to attain a uniform cap. Single placement events resulted in cap thickness increases of only a few centimeters when the material was released immediately around the placement point while the vessel was stationary. By spacing placement points so that the bottom surge areas from neighboring points overlapped one another, the cap could be gradually and uniformly built up with limited disturbance to the EA layer. This approach was likely a large contributor to the creation of uniform caps.

a. Can multiple loads of cap material be placed accurately and consistently based upon a predetermined cap placement plan?

Although each placement event occurred during varying environmental conditions (e.g., surface currents, wind speed, and direction) and under different engineering controls (e.g., different dredge captains, slightly different rates of discharge, etc.), the ADISS monitoring results showed that a large hopper dredge could be operated to consistently meet a predetermined cap placement plan. In addition, the side-scan sonar and SPI monitoring results showed good spatial correlation between the hopper location at the sea surface during placement and the subsequent deposit of material on the seafloor (i.e., the cap material experienced little lateral displacement as it fell through the water column).

b. How far did the cap material spread on the seafloor following placement?

For the single hopper placement technique employed in Cells LU and SU, the cap material spread out laterally in a concentric pattern upon impact with the bottom, as expected based on extensive past experience and model predictions. This resulted in a deposit of cap material on the seafloor that was thickest near the point of impact and increasingly thinner toward its outer edges. For the initial spreading placement in Cell LD the contour map showed that the cap material spread between about 75 to 150 m on either side of the track line in most of the cell. The spread of material was greatest near the beginning and again at the end of the track line. The greater spread of material in the southeastern half of the cell, near the beginning of the track line, correlates well with the ADISS data showing that 75 percent of the load was placed in this location. The SPI results likewise agreed well with those from the Post-1 side-scan sonar survey, which show a circular feature near the beginning of the track line attributed to a larger quantity of cap material released in this location.

The Post-1 SPI results showed the initial cap material deposit in Cell LU had a diameter of 200 to 250 m, while the deposit in Cell SU had a diameter of 275 to 325 m. In both cells, the positioning of the SPI sampling stations within the cell, relative to the hopper's location at the sea surface during placement, proved adequate for constructing contour maps illustrating the spread of material. Despite differences in depth and bottom slope, the initial deposit on the seafloor was roughly circular in both cells, and the contours formed concentric rings of decreasing cap material thickness toward the outer edges. These results were generally consistent with model predictions and serve to illustrate an overall evenness in the lateral spread of material around the central point of impact. Confirming the ability to create a relatively symmetrical deposit of material on the seafloor through point placement on the PV Shelf is a significant study outcome. Given the results of the initial single hopper point placement events, it is clear that using multiple, sequential point placements was a successful approach to constructing the caps with uniform thickness.

The Post-71 SPI sampling in Cell LU showed that the outer edge of the cap material deposit extended as far as 200 m beyond the cell boundary to the southeast (alongslope), but less than about 100 m beyond the boundary to the northeast (upslope). In the Post-21 far field survey in Cell SU, the outer edge of the cap material deposit extended roughly 200 m beyond the cell boundary to the southwest (downslope), but less than 100 m beyond the boundary to the southeast (alongslope). Somewhat greater lateral spread in the downslope direction compared to the alongslope/upslope directions is consistent with expectations and will need to be accounted for in any future modeling efforts.

After nine spreading placements in Cell LD, SPI indicated the deposit was uniformly distributed on the seafloor at distances of 200 to 300 m on either side of the track lines, in both the upslope and downslope directions. There was some evidence that the material had spread slightly farther in the downslope direction, as thin cap layers were observed at more of the downslope SPI stations located outside the cell boundary compared to the upslope. The Cell LD Post-9 cap thickness contour map also shows slight bulges, indicating wider spreading, near the center of the two halves of the cell compared to the cell center. The slightly wider spread of material on the seafloor at the two ends of the cell probably reflects somewhat higher volumes of material placed in these locations as a result of the variability in release rate from the hopper dredge. There was good agreement between these SPI results and the side-scan sonar records showing circular surge features around the locations where larger quantities of cap material were released. For Cell LD as a whole, both the SPI and side-scan sonar results indicate a fairly homogenous lateral spread of cap material following the nine spreading placement events.

c. How much variability was there in cap thickness?

Analysis of SPI data indicated that cap thickness measurements varied by less than about 2 cm among the three replicate SPI images obtained at each station in Cells LU and SU and 1 cm among the SPI replicates in Cell LD. It is possible to conclude that across relatively short horizontal distances on the seafloor (i.e., a few meters between replicate images), there was very little variability in cap material thickness. Likewise, the SPI cap thickness contour maps for the early surveys (i.e., Post-1 and Post-5) clearly demonstrated that the seafloor deposits resulting from release of individual hopper loads of cap material consisted of a series of concentric rings having uniform thickness. These maps show how the individual placement events were resulting in relatively flat, uniform, pancake-like deposits that were thicker near the center and tapered gradually and evenly toward the outer edge, as expected based on model predictions. There was little variability in cap thickness within each concentric ring.

The Post-25 and Post-45 SPI surveys in Cell LU and the Post-21 survey in Cell SU provided some confirmation, albeit limited, of the ability to construct a uniform cap across each cell. In Cell LU, the SPI results for both surveys showed that cap thickness was consistently greater than 8 to 12 cm across the entire cell. This was partial evidence of uniformity, in the sense that all of the

individual station results were consistent in showing cap material thickness exceeding the penetration depth of the SPI camera. Coring provided some additional, albeit limited, confirmation of the general trend in cap thickness across the cell. Cap thickness observed in cores was greater in the central portion of the cells where most of the cap had been placed and was able to extend the estimate of cap thickness beyond that determined with SPI.

Cap thickness within each of the Post-21 concentric rings in Cell SU was relatively uniform, with the exception of the anomalous results from one station, where thickness varied significantly from the surrounding stations. Additional SPI sampling in the Post-21 far field survey confirmed that cap thickness varied by up to 7 cm within a 25-m radius of this station, despite the fact that it coincided with a placement location. The results are considered anomalous because this is the only instance in multiple surveys where this kind of variation from the uniform, concentric ring pattern was observed. This station was located upslope from the center of the cell, where most of the placement was concentrated. The thinner cap layer at this station may have reflected preferential downslope movement of the cap material upon impact with the bottom.

Following nine spreading placement events in Cell LD, the cap material deposit continued to show uniform thickness on either side of the central track line (i.e., the thickness contours are symmetrical around the center of the cell), with some variation in thickness along the track line related to the variable rates of release.

Overall, the SPI results in Cells LU, SU, and LD indicate a fairly consistent pattern in the construction of relatively homogenous layers of cap material. The initial placement in both cells produced a circular and gradually tapered deposit with the generally uniform thickness contours creating the appearance of concentric rings around the placement point. As this pattern was repeated in multiple subsequent placement events, cap thickness increased uniformly near the placement locations, and the overall footprint of the deposit spread outward in a fairly symmetrical pattern. Even though the cap thickness data have some limitations when the cap began to exceed about 8-10 cm (e.g., SPI penetration limits), we inferred from the thinner areas and the small number of gravity cores that the cap was being built up evenly. Thus, we are confident that those areas having thicker cap also exhibited reasonable uniformity.

d. What is the effect of water depth, bottom slope, and cap material type on a point placement?

Cells LU and SU both received sediments dredged from the Queen's Gate entrance channel, so it was not possible to comment upon the potential effects of different cap material types in these two cells. Cell SU was both deeper (65 m) and had greater slope (3.2 deg) than Cell LU (depth = 40 m; slope = 0.9 deg). The Post-1 SPI results indicated that the initial cap material footprint was considerably wider in Cell SU compared to LU (Post-1 SU diameter = 275 to 325 m; Post-1 LU diameter = 200 to 250 m). The greater depth of Cell SU

presumably allowed the cap material to spread somewhat further than at the shallower Cell LU.

The Post-1 SPI monitoring did not show any preferential spread of material in the downslope direction in either cell, particularly Cell SU, which might be expected if the difference in slope was a factor. Likewise, the Post-1 side-scan images from both cells generally showed the cap material deposit as a round, symmetrical feature with an inner high-reflectance disturbance area that correlated well with the 4-cm SPI cap contour, and a lighter radial spreading pattern that correlated well with the 2-cm SPI cap contour. Beyond the 2-cm contour, no definitive differences between the cap and ambient sediment could be detected on the side-scan images. These general characteristics were very similar in both Cells LU and SU.

The Post-5 SPI monitoring indicated that the cap material deposits in the two cells were largely similar in thickness and distribution, although the measured thickness at the upslope stations in Cell SU was somewhat less than that in Cell LU. This suggests that the steeper slope in this cell may have resulted in some preferential accumulation of cap material in the downslope direction compared to Cell LU, as might be expected. Likewise, the Post-5 side-scan records from Cell SU show a greater distribution of the lateral surge material moving in the downslope direction, whereas the side-scan records from Cell LU show a more uniform surge pattern around the entire placement area.

The Post-45 SPI monitoring in Cell LU generally indicated an even distribution of cap material within and outside the cell, although slightly thicker cap layers observed at the distal downslope stations compared to those upslope again suggest a minor effect of slope. In contrast, the Post-21 SPI results from Cell SU failed to show a strong influence of slope, as cap layer thickness at the distal upslope stations was greater than those downslope. These somewhat confounding results lead to the conclusion that the difference in depth and slope appears to have played a relatively insignificant role in the creation of uniform cap material deposits in Cells LU and SU.

e. Following placement of the pilot cap, was there considerably more seafloor topography than observed during baseline surveys?

Based on comparisons between the postcap and baseline side-scan sonar data there appeared to be no major changes in bottom topography after the capping operations were completed in the cells. For instance, no significant slumping or movement of material was observed within the side-scan imagery. Had all of the cap material been placed in only a few locations creating more prominent topographic mounds relative to the surrounding seafloor, then these features would have been reflected within the imagery. However, because the cap material was spread evenly around the cell and the resulting topographic changes were minor, the side-scan imagery did not reflect any topographic changes. Likewise, the sediment plan view images did not indicate any significant, consistent increases in small-scale surface roughness following the cap placement

events. The cap surface in the majority of plan view images appeared relatively flat or with small ripples, similar to those observed in the baseline monitoring.

3.9.2 Can disturbance to in-place sediments be kept within tolerable limits?

Some physical disturbance to the EA sediment was observed, but this appeared to be within expectations of only a few centimeters. This disturbance was minimized during the pilot study through the management of cap placement points. In addition, it appears that the spreading placement approach has the potential to result in even less disturbance to in-place sediments than conventional placement.

Disturbance to the EA sediment was evident in the SPI photographs and in the cores. SPI photos were able to observe the partial or complete loss of the 2-3-cm thick precapping sediment oxidized layer at some of the stations. This observation was particularly evident at stations close to the first few cap placement points in Cells LU and SU. However, once subsequent cap began to occur only over bottom with areas where cap laterally surged from prior events, there appeared to be some protection provided to the EA sediment that lessened the disturbance. Spreading placement in Cell LD appeared in SPI photos to result in even less disturbance to the EA sediments. This is certainly a result of the smaller mass of sediment released over any given area and the slower impact and surge velocities.

Water quality measurements also support a conclusion that the impact to the EA sediments was not unacceptably adverse. The highest occurrence of DDE in the resuspended near-bottom plume in Cell LU occurred on the very first placement event. The observed value was 0.29 ug/L, about two orders of magnitude greater than baseline of 0.005 ug/L. Subsequent measurements in the same plume showed a rapid return to baseline levels. The next monitored events in Cell LU (events 4 and 5) appeared to result in much less resuspension of EA sediment as peak concentrations were about an order of magnitude less (0.017 and 0.010 ug/L) than the first event and only two to three times greater than baseline. These placement events occurred in the same location as the previous three events and the EA sediments were likely shielded from direct impact by the cap already in place. Similarly, monitoring of the near-bottom plume in Cell SU observed a peak value of DDE immediately following the first placement event with levels nearing baseline within about 30 min. Thus, the potential for significant impacts to water quality during a full-scale operation appear to be minimal.

a. To what degree were the in-place sediments disturbed as a result of cap material placement?

The SPI monitoring for the conventional placement operations in Cell LU and SU and spreading placement in Cell LD provided estimates of the depth to which the in-place sediments were disturbed based on direct visual observation

of the remnant RPD (or absence thereof). It is important to note that in sediment profile images where the layer of lighter colored surface sediment (i.e., former RPD) appeared to be completely missing, the estimated depth of disturbance represents a conservative or minimum estimate. In such instances, the actual depth to which the in-place sediments were removed may have been significantly deeper than the depth of the former RPD, and the estimated depth of disturbance is denoted as greater than some measured value.

The initial monitoring results for Cells LU and SU (i.e., Post-1 and Post-5) were largely consistent in showing that the in-place sediments appeared to be disturbed to the highest degree near the center of the cap material deposits. This presumably represents the initial point of impact of the cap material with the bottom, and the higher energy levels would be expected to cause greater disturbance to the in-place sediments. It is important to note that the interpretation of the SPI results is limited in that it does not address what happened to the in-place sediments when they were disturbed. It is reasonable to assume that some of this disturbed sediment mixed with the cap material and became part of the cap deposit, and some was displaced into the water column to become part of the near-bottom plume.

At stations having cap material but located outside the initial point of impact, the depth of in-place sediment disturbance typically was limited to less than about 2 or 3 cm (i.e., less than the depth of the former RPD). Such stations presumably experienced the placement energy mainly in the form of a lateral surge of cap material, with less apparent disturbance to the in-place sediment than at the point of impact. Finally, a significant result of the SPI monitoring is the observation that the RPD generally remained intact at stations located immediately outside the footprint of the cap material deposits in Cells SU and LU. These results indicate that the instantaneous surge of water resulting from the cap placement had insufficient energy to resuspend the in-place sediments outside of a relatively limited area surrounding the point of impact.

For the spreading placement in Cell LD, the SPI monitoring generally showed that the greatest disturbance (roughly 2 or 3 cm) occurred at stations along the track line of the dredge, particularly where larger volumes of material were released and thicker layers of material subsequently accumulated on the bottom. Outside the immediate vicinity of the track line, the depth to which the in-place sediments appeared to be disturbed was generally limited to less than 2 cm. In general, the results suggest that the lateral surge of cap material resulting from spreading placement produced somewhat less disturbance of the in-place sediments than conventional placement. Similar to the results from Cells LU and SU, the SPI monitoring in LD showed that there was no apparent disturbance to the in-place sediments at stations located outside the cap material footprint. At these stations, the 2-3 cm layer of light colored sediment comprising the RPD remained in place, despite the passage of a placement surge.

b. Does the cap placement operation cause high concentrations of contaminants in the water column immediately following placement, as a result of resuspension of ambient sediments?

Measurements of the velocity and duration of surge currents indicated that currents had sufficient energy to resuspend bottom sediments into overlying waters and scour the EA sediment layer. However, surge current velocities were sufficient to resuspend bottom sediments (ambient and/or cap material) only within about 100 m of the placement site. Thus, for all but the first load of cap this activity would have occurred largely over areas with some cap present as a protective layer.

Water quality measurements in Cell LU up to 2 hr following each of cap placement events 1, 4, and 5 revealed high, near-bottom turbidity levels in proximity to the placement site immediately after placement; light transmittance levels dropped to 0 percent immediately following the placement event. Maximum TSS and total (dissolved plus particulate) DDE concentrations measured at the centroid of the suspended particle plumes were 1,600 mg/L and 0.29 µg/L, compared to baseline concentrations of 4 mg/L and 0.013 µg/L, respectively. Although the spatial extent of the resuspended sediment plumes was not accurately determined, turbidity levels and TSS and DDE concentrations in waters outside of the plume centroid are expected to be much lower than peak levels, immediately following the placement event.

Water quality measurements within Cell SU indicated similar increases in turbidity levels in near-bottom waters immediately following cap placement. Maximum TSS and DDE concentrations were 1,100 mg/L and 1.2 µg/L, respectively. The peak DDE concentrations were relatively higher than those in Cell LU, consistent with the several-fold higher DDE concentrations in surface sediments measured in Cell SU compared to Cell LU.

A large portion of the measured turbidity and elevated TSS concentrations likely were due to suspended cap particles settling through the water column rather than resuspended bottom sediments. For example, maximum TSS concentrations in Cell LU bottom waters, following the initial placement event, were approximately 400 times higher than baseline, whereas maximum DDE concentrations were approximately 22 times above baseline. Thus, a substantial portion of the TSS load did not contribute to water column DDE concentrations and, therefore, probably represented cap sediments with low DDE levels. The proportion of cap sediments contributing to TSS can be estimated by comparing the DDE concentrations measured in the water column samples with average DDE concentrations in cap material and surface sediments within the two cells, and assuming that all of the DDE in the water samples was associated with particles. With this approach, cap material contributed approximately 90 percent and 80 percent of the TSS following initial cap placement within Cells LU and SU, respectively.

Water quality measurements in the vicinity of Cell LD during the 2 hr following initial cap placement revealed a spike of low light transmittance

(0 percent) and correspondingly high near-bottom turbidity levels. Maximum TSS and total DDE concentrations measured at the centroid of the suspended particle plume were 350 mg/L and 0.1 µg/L, compared to baseline concentrations of 2 mg/L and 0.006 µg/L, respectively. As expected, these maximum TSS and DDE concentrations were lower than those associated with conventional placement methods used in Cells LU and SU. Similar to Cells LU and SU, most of the measured turbidity and elevated TSS concentrations in Cell LD likely were attributable to suspended cap particles settling through the water column rather than resuspended bottom sediments.

c. Do water quality impacts persist after individual placement events?

Water quality measurements at the cells demonstrated that water column properties returned rapidly to baseline conditions following each monitored cap placement event. In particular, turbidity levels and TSS concentrations declined from peak levels occurring immediately after release of cap material to near baseline levels within a period of approximately 2 hr for Cells LU and SU. For Cell LD a return to baseline conditions occurred within 30 min. Further, DDE concentrations in the water column decreased to approximate baseline levels within a period of 30 min at all cells. This suggests that particles remaining in the plume following the initial settlement period (i.e., 30 min) consisted primarily of suspended cap materials.

d. Do high concentrations of water column contaminants occur only following the first placement event in each cell (i.e., does potential for water quality impacts decrease as proportionately greater portions of a cell are capped?)

With the exception of the initial placement event in each cell, construction of the pilot study cap involved placement of individual cap loads on top of existing cap material deposits. The purpose of this approach was to minimize disturbances to existing sediments. As a consequence, impacts to water quality associated with the initial placement would be expected to be more extensive than those associated with subsequent placement events. This can be evaluated by comparing water quality measurements performed in Cell LU following Events 1, 4, and 5.

Maximum TSS concentrations measured during Events 1, 4, and 5 were 1,600 mg/L, 3,400 mg/L, and 2,700 mg/L, respectively, and did not exhibit any clear temporal trends. In contrast, maximum DDE concentrations measured during Events 1, 4, and 5 were 0.29 µg/L, 0.017 µg/L, and 0.10 µg/L, respectively. Therefore, peak DDE concentrations in the water column following Events 4 and 5 were considerably lower than those associated with the initial placement event, and proportions of TSS represented by resuspended bottom sediments during the Post-4 and -5 events were negligible (<1%). The trend observed at Cell LU indicates that the approach used to place successive cap loads on top of existing cap material appeared to be effective at minimizing disturbances of existing sediments.

e. What is the likelihood that near-surface plumes of suspended cap material are transported inshore to existing, near-shore kelp forests?

Plume monitoring observations indicated that there is a very low risk of unacceptable quantities of suspended sediments being transported to the kelp beds located approximately 1,000 m closer to shore. The monitoring of shallow plumes (surface to 10 m depth) were consistent with the alongshore transport observations of the deeper plumes (30-70 m) conducted to assess EA sediment resuspension. While some of the deeper plume tracking surveys did detect onshore movement, the results showed no more than a 200-m shoreward transport. Further, this was usually observed around the time of slack water such that any onshore movement would likely be quickly overwhelmed by the strong alongshore ebb and flood currents. Light transmission and suspended solids levels reached or approached baseline during the 2-hr duration of all three near-surface plume surveys. In particular, the A-III sand sediments produced very little detectable presence of suspended sediment in the water column and caused very little change in the light transmission characteristics of the water. Further, even though the data are limited, the multiday records from the current meter quadrapods showed no instances of strong onshore water movement.

3.9.3 Does the cap remain clean?

Other than a certain degree of mixing that occurred when initial layers of cap were placed, we were able to achieve a clean cap as thickness began to increase. The process of cap placement resulted in about 3-4 cm of the cap becoming mixed to some degree with the EA sediment. As cap thickness increased beyond this, mixing with the EA sediment became negligible such that the upper portions of the cap had very low levels of DDE.

a. What is considered clean?

The minimum detected concentration of DDE in the Queen's Gate sediment was 0.02 mg/kg. Assuming some degree of variability in the cap material, a concentration of 0.02 ± 0.07 mg/kg or less than 0.1 mg/kg is considered representative of the Queen's Gate DDE levels.

b. Following completion of the pilot capping operation, was the established cap free of contaminants originating from the ambient sediments?

Overall, the postcap coring results in Cells LU and SU served to demonstrate that the near-surface layers of the cap material had DDE concentrations similar to the levels observed from samples prior to their dredging and placement. These surface layers were found to be overlaying deeper horizons of mixed EA and cap sediment.

c. What was the degree of mixing between the cap material and ambient sediments?

In both Cells LU and SU, the SPI frequently indicated a thicker cap than was captured in the gravity core. Despite the apparent loss of the surface layer of cap material from cores, cores from both cells collected a cap layer with DDE concentrations less than 0.1 mg/kg DDE.

In Cell LU after 45 placement events, the top 4-8 cm horizon of the cores from the central portion of the cell had DDE levels similar to the Queen's Gate source material. After 71 placements, the 8-12 cm sample horizon reflected dominantly Queen's Gate source material. Below the surface material was a mixed horizon that varied in thickness and DDE concentration between the cells. In Cell LU, after 45 placement events, the depth at which DDE concentrations began to increase toward ambient levels was in the 8-12-cm sample horizon. This depth increased to the 12-16-cm sample horizon after 71 placement events.

Cores collected from the center of SU, where SPI indicated more than 10 cm of cap material contained a 4-cm horizon of cap material similar in DDE concentration to the Queen's Gate source material. In SU cores collected at locations of limited cap placement, the top core horizon contained DDE concentrations similar to or slightly lower than baseline. It is believed that coring artifacts disrupted at least the top 6 cm of sediment, thereby hindering assessment of DDE concentration at the surface of the cell. Assuming the surface material followed the concentration trends of the deeper sediments, the surface material displaced in sampling probably contained less DDE than the actual top core horizon. In both cells, the cap layer thickness captured by the gravity corer was less than observed with SPI. Adding the missing 6 cm to the surface of each core reflects thicknesses closer to those predicted for the volume of sand placed in each cell. In Cell LU, adding the missing 6 cm of material increases the estimated cap thickness over the central portion of the cell to 18 cm, with a mixed zone starting at 18 cm. Likewise, Cell SU would contain an estimated 10 cm of cap having concentrations similar to the Queen's Gate source, with mixing beginning between 10-14 cm.

3.9.4 Does the cap remain stable during placement?

We observed no evidence of cap or EA sediment instability as a result of operations. Current surge monitoring results indicated that the energy from the cap placement decayed with distance and time away from the point of release. This lessens concerns about the potential to trigger downslope turbidity flows. We did observe that at the steeper sloped Cell SU, the current speed decay was not as prominent. If the issue of turbidity flow creation does remain an unacceptable concern, use of spreading placement, which produced very little surge, would be the recommended option in such locations.

None of the other tools used to observe the state of the EA sediment and cap, i.e., SPI, PVC, side-scan sonar, sub-bottom sediment profiling, provided any

indication of sediment instability. We observed no large-scale deformations or changes in the seafloor around the cells and in particular downslope. Beyond the cap margins, SPI and PVC showed an ambient seafloor that was unaffected by the physical process of multiple capping events that had gone on nearby at a distance of only tens of meters.

a. Did the initial cap placement event in Cells LU and SU cause a strong surge current at the seafloor that resulted in considerable lateral transport of ambient sediment away from the placement location?

During each of the five placement events monitored in Cell LU, a distinct surge current was observed, having current speeds that were much greater than the weak ambient bottom currents. Within 100 m of the placement site, maximum bottom surges ranged from 70 to 125 cm/sec for all eight instrument records acquired during five placement events, and this surge current was always directed radially away from the point of the cap placement. The horizontal momentum of this surge current rapidly decreased with distance from the placement site, to the extent that maximum speeds had decreased to the range of 30 to 60 cm/sec at a distance of 150 m downslope from the placement site, and to maximum speeds of only 20 cm/sec (roughly comparable to the ambient currents) at a distance of 250 m in the downslope direction from the site. In terms of persistence, the surge events were brief, with current velocities returning to ambient levels at all measurement sites within approximately 10 to 15 min after passage of the surge. Overall, the observations of maximum near-bottom current velocities and persistence within the surge of the five separate placement events agreed closely, to the extent that these data can be viewed as statistically representative of the conventional cap placement process at Cell LU. Overall, these multidisciplinary survey results document that bottom surges were generated during conventional placement operations in Cell LU, but their effects were generally confined within approximately 200 m of the placement location.

The current meter observations in Cell SU revealed a distinct surge current having current speeds that were much greater than the weak ambient bottom currents, and this surge was similar to those observed during the five placement events in Cell LU. Maximum current speeds during the surge at the downslope array locations in Cell SU were comparable to those observed at similar distances from the placement locations in Cell LU. The results from the three downslope locations in Cell SU suggest that current speeds in the surge did not decrease as rapidly with distance from the placement site, as had been observed in Cell LU, but these observations from a single placement event in Cell SU did not represent a statistically significant data set from which to draw conclusions about differences in surge characteristics between the two cells. Because the bottom slope in Cell SU (3.2 deg) was 3.5 times steeper than that within Cell LU (0.9 deg), it is possible that the momentum of the surge energy in Cell SU was dissipated at a slower rate (per unit of distance) than the surge within Cell LU. If this were the case, the surge at Cell SU could possibly transport suspended particulates farther from the cap placement site, than would occur at Cell LU.

Maximum current speeds during the surge in Cell LD were 35 cm/sec at both the 80-m upslope and 60 downslope array locations compared to maximum speeds that exceeded 120 cm/sec for some of the surge events during conventional placements in Cell LU. The maximum current speed of 20 cm/sec at the 240-m downslope array location at Cell LD revealed that current speeds in the surge decreased with distance from the placement site (spreading line) as had been observed in Cell LU which had a similar bottom slope as Cell LD.

The turbidity records acquired within the surge event in Cell LD demonstrated that turbidity levels within the surge for this event were much lower than those observed at the same distances (both upslope and downslope) from the placement site for events in Cells LU and SU. Maximum turbidity levels at the upslope location were 8 to 10 times less than those measured for events in Cells LU and SU. And at the downslope array locations, turbidities were four to 10 times less than those measured for the other cells.

b. What is the potential for creation of turbidity flows and mudwaves?

Turbidity flows

The moored current data acquired during cap placements in Cell LU demonstrated that horizontal velocities in the bottom surge decreased with distance from the placement location for all five events monitored. And since all conventional placement operations in Cell LU were conducted in the same manner, these surge data should be representative of all placement events in Cell LU. Therefore, it can be concluded that turbidity flows were not generated during cap placement operations in Cell LU. Similarly, the moored current data acquired during the spreading event in Cell LD demonstrated that horizontal velocities in the bottom surge decreased with distance from the placement location.

The most significant difference between surge data acquired at LU and SU was that the data from the two downslope measurement sites in Cell SU showed less of a decrease in surge velocities over the distance between these two stations, as had been observed during surge events in Cell LU. While these results neither prove nor disprove that a turbidity flow occurred during placement Event 1 in Cell SU, they do show that the velocity characteristics of the surge in Cell SU may have been different from those within Cell LU. Because the bottom slope in Cell SU was 3.5 times steeper than that of Cell LU, we would expect that the rate of spatial dissipation of surge velocities would be less for the steeper location. Similarly, the surge may have traveled farther downslope from Cell SU even in the absence of a turbidity flow. Additional field measurements during cap placement operations, and/or numerical modeling of the surge and turbidity flow processes would, however, be useful to substantiate any conclusions about turbidity flows in the vicinity of Cell SU. However, following all placement events, physical evidence of seafloor conditions around the perimeter of the cap deposit from SPI, plan view photographs, side-scan sonar, and sub-bottom sediment profiling showed no evidence of disturbance by turbidity flows.

Mudwaves

Another topic of concern about the capping operation was whether the ambient sediments underlying the newly formed cap would have sufficient gravitational potential that the underlying sediments could shift laterally under the weight of the cap and find a location to escape (breach) the cap layer. This process has been called a mudwave to associate it with potential horizontal transport of material (mud or underlying ambient sediment), versus the diapir process where underlying capped sediments breach an overlying cap by moving vertically, as within a chimney. During a recent project in Boston Harbor which involved placing a thick (i.e., 1-m) cap over recently dredged material that had been placed in a confined aquatic disposal (CAD) cell (pit), diapir structures developed within the cap, and underlying dredged material was found on top of the cap in various locations within the cell (Fredette et al. 2000). It is, however, important to point out that for the Boston Harbor CAD cell project that a large volume of dredged material with very high water content was placed within the vertical walls of the CAD cells and effectively prevented from moving horizontally. Consequently, the 1-m sand cap placed over the unconsolidated dredged material in the Boston Harbor CAD cells was a much different situation than the relatively thin (2-20 cm) cap that was placed during the Palos Verdes pilot capping program over relatively consolidated ambient sediments that had been in place for decades before this capping project. For this reason, diapirs were not expected to be a significant process for breaching of the pilot study cap resulting from conventional placements in Cells LU and SU.

Similarly, for a mudwave to develop under the pilot study cap, this would require: a) substantial overlying weight from a thick cap, and b) relatively mobile, high-water content sediments underlying the cap. Since neither of these conditions were met in the present study, mudwaves were not expected to occur following placement of the pilot study cap. If, however, they had occurred, the spatial information acquired during the sequential side-scan sonar and sub-bottom sediment profiling surveys would be the principal means of detecting this process. If the cap had been breached by a mudwave and a large volume of ambient sediment was lying on top of the cap material, the side-scan record may have revealed small-scale topographic relief at the location where the underlying material was ejected, and there may also have been a visible region of irregular side-scan signal strength, due to the transition in return signal strength associated with the boundary from cap material to the mobile ambient material. Because no such topographic relief nor irregular signal strength patterns were detected during any of the side-scan sonar and sub-bottom sediment profiling surveys, it is believed that mudwaves did not occur immediately following the capping operations.

**Table 3-1
Monitoring Vessels Used during Pilot Cap Construction (First Five Listed) and 2001 Survey (Last Vessel on List)**

Vessel Name	Operator	Home Port	Dimensions (m)		
			Length	Beam	Draft
<i>R/V Sea Watch</i>	Southern California Marine Institute	Terminal Island, CA	20	7	1.5
<i>R/V Yellowfin</i>	Southern California Marine Institute	Terminal Island, CA	23	7	2.6
<i>M/V Tuna</i>	Pacific Tugboat Service	San Diego, CA	12	5	1
<i>R/V Sea World</i>	UCLA Marine Science Center	Marina del Rey, CA	19.5	5.5	2.4
<i>M/V Bottom Scratcher</i>	Greg Elliot	Long Beach, CA	19	5.5	1.2
<i>R/V Wm. A. McGaw</i>	SAIC - Maripro	Santa Barbara, CA	32	8	3.8

Table 3-2 Problem Statements, Monitoring Objectives, and Techniques for Monitoring		
Problem Statement	Monitoring Objectives	Monitoring Techniques
Does placement occur as modeled?	Measure distribution and thickness of cap during separate phases and under different cap placement scenarios; Provide information/data for comparisons with USACE model predictions of sediment accumulation/spreading within capping areas.	1) Sediment profile imaging 2) Plan view photography 3) Sub-bottom profiling 4) Side-scan sonar 5) Coring for sediment chemical and physical parameters 6) Dredge positioning and load measurements 7) Hopper dredge sampling 8) Bottom-mounted array water column current measurements
Can a cap with uniform thickness be constructed?	Determine ability to control cap placement, spatial variability/uniformity of cap thickness, and validate model predictions.	1) Sediment profile imaging 2) Sub-bottom profiling 3) Coring
Does resuspension of in-place sediments and water column dispersion of capping material occur as modeled?	Provide information/data for comparisons with model predictions of surge following cap placement, lateral extent of disturbance, and evaluate effect of EA sediment resuspension on water column concentrations of TSS and contaminants relative to background levels.	1) Current and optical backscatter measurements to detect surge and plume (OBS/ADCP) 2) Plume mapping and water column sampling for TSS and DDE (transmissometer, rosette sampler) 3) Video documentation 4) Sediment profile imaging 5) Sub-bottom profiling and side-scan sonar 6) Drogue tracking
Does cap remain clean?	Determine contaminant concentrations in cap immediately following placement, and extent of mixing of EA sediments and cap material.	1) Sediment profile imaging 2) Coring
Does cap remain stable?	Determine stability of cap during and immediately after cap construction by assessing cap distribution over EA deposit and changes in lateral surge velocities during cap placement.	1) Sediment profile imaging 2) Plan view photography 3) Coring 4) Side-scan sonar 5) Currents and optical backscatter measurements using bottom mounted arrays

Table 3-3 Physical Characteristics of Pilot Capping Cells as Observed in Baseline Data								
Mean Physical Characteristics on Selected Core Sections								
Cell	Liquid Limit		Plastic Limit		Bulk Density (g/cc wet)		% Sand	
Core Section (cm)	0-8	8-20	0-8	8-20	0-4	16-20	0-8	12-20
LU	36	39	33	32	1.76	1.73	58	58
LD	41	43	30	30	1.71	1.73	49	48
SU	89	124	36	48	1.51	1.34	20	11
SD	71	104	34	40	1.57	1.34	23	11

**Table 3-4
Matrix of Instrumentation Used for Various Deployments in Cells LU, SU, and LD**

Cell	Material Placement Event	Material Placement Date	Material Placement Time (GMT)	Mooring Deployment	Oceanographic Dataset Name	Mooring Location	Water Depth (m)	Aquadopp Current Sensors	OBS Turbidity Sensors	ARESS Current Sensors	OBS Turbidity Sensors	ADCP Current Profiler
LU	1	8/2/2000	19:21	1	PV-A-1	75 m Downslope 150 m	45	1	1	2	2	1
		*	*	*	PV-B-1	Downslope	45	1	1			
SU	1	8/10/2000	18:34	2	Array moved*	475 m Downslope	172	1	1			
		*	*	*	PV-G-1	75 m Downslope	64			2	2	1
		*	*	*	PV-H-1	115 m Downslope	65			2	2	
		*	*	*	PV-I-1	170 m Downslope	74			2	2	
		*	*	*	PV-J-1	75 m Upslope	60	1	1			
LU	2, 3, 4 & 5	8/13/2000	4 different times	3	PV-D-2	75 m Upslope	42	1	1			
		*	*	*	PV-A-2	75 m Downslope	45			2	2	1
		*	*	*	PV-B-2	150 m Downslope	46			1	2	
		*	*	*	PV-C-2	250 m Downslope	47			2	2	
LD	1	8/15/2000	19:15	4	PV-P-1	75 m Upslope	42	1	1			
		*	*	*	PV-L-1	75 m Downslope	43			2	2	1
		*	*	*	PV-M-1	150 m Downslope	48			1	2	
		*	*	*	PV-N-1	250 m Downslope	49			2	2	
East of Cells LU and SU	None (array not within cells)	30-day record		2 separate deployments	PV-X	East of Cells LU & SU	52					1

* The array initially placed at 150 m upslope in Cell SU was snagged by a vessel and inadvertently moved to a position 475 m downslope before the placement event occurred at this cell.

**Table 3-5
Actual Distances from Moored Arrays to Cap Placement Locations for all Events
Monitored in Cells LU, SU, and LD**

Cell	Deployment	Event	Upslope "75"	Downslope "75"	Downslope "150"	Downslope "250"	Downslope "475"
LU	1	1	nd	100	165	nd	nd
	3	2	50	70	150	250	nd
	3	3	55	80	160	260	nd
	3	4	75	70	135	240	nd
	3	5	75	60	140	240	nd
SU	2	1	80	60	115	170	475
LD	4	1	80	60	145	240	nd

nd = no deployment

Table 3-6
Summary of Data Return from Current Measurement Equipment Deployed in Cells LU, SU and LD

Material Placement Date	Material Placement Time (GMT)	Mooring Deployment	Array Locations										
			75 m Upslope	75 m Downslope	115 m Downslope	150 m Downslope	170 m Downslope	250 m Downslope	475 m Downslope				
8/2/2000	19:21	1		100%		100%							
				100%	Ended before placement								
8/8/2000	18:34	2	100%	No data	100%			100%					100%
				100%									
8/13/2000	7:32	3	100%	100%			100%			100%			
				100%									
8/13/2000	10:58	3	100%	100%			100%			100%			
				100%									
8/13/2000	16:59	3	100%	100%			100%			100%			
				100%									
8/13/2000	20:19	3	100%	Battery expired			100%			100%			Battery expired
				100%									
8/15/2000	19:15	4	100%	100%			100%			100%			100%
				100%									

ARESS current sensor
 Aquadopp current sensor
 ADCP current profiler

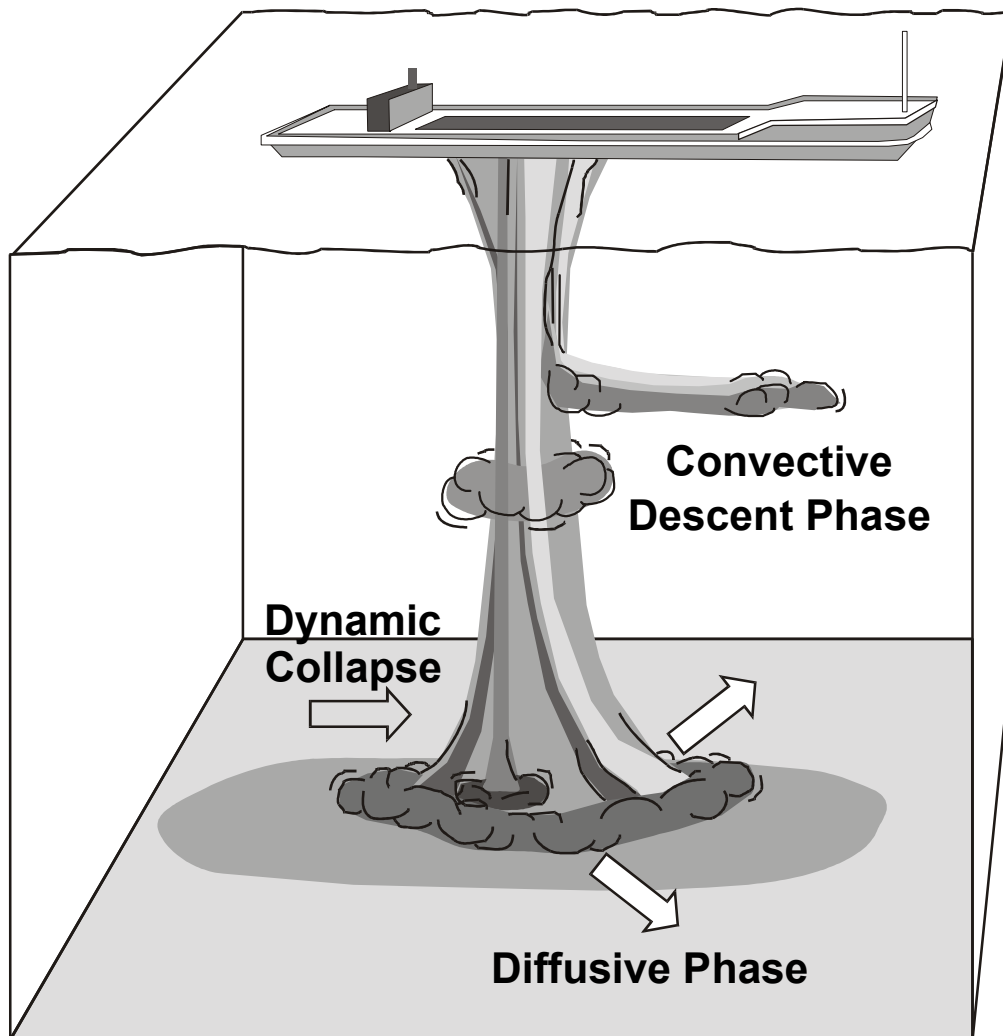

Figure 3-1. Phases of sediment behavior following release from transport vessel



Figure 3-2. Palos Verdes pilot capping area and locations of Southern California Marine Institute (SCMI), Queen's Gate harbor entrance, and the A-III borrow site relative to Los Angeles and San Pedro



Figure 3-3. Southern California Marine Institute (SCMI)



Figure 3-4. Survey planning and data processing at Southern California Marine Institute



Figure 3-5. *RV Sea Watch*, one of vessels used during field monitoring operations



Figure 3-6. *MV Tuna*, one of vessels used during field monitoring operations

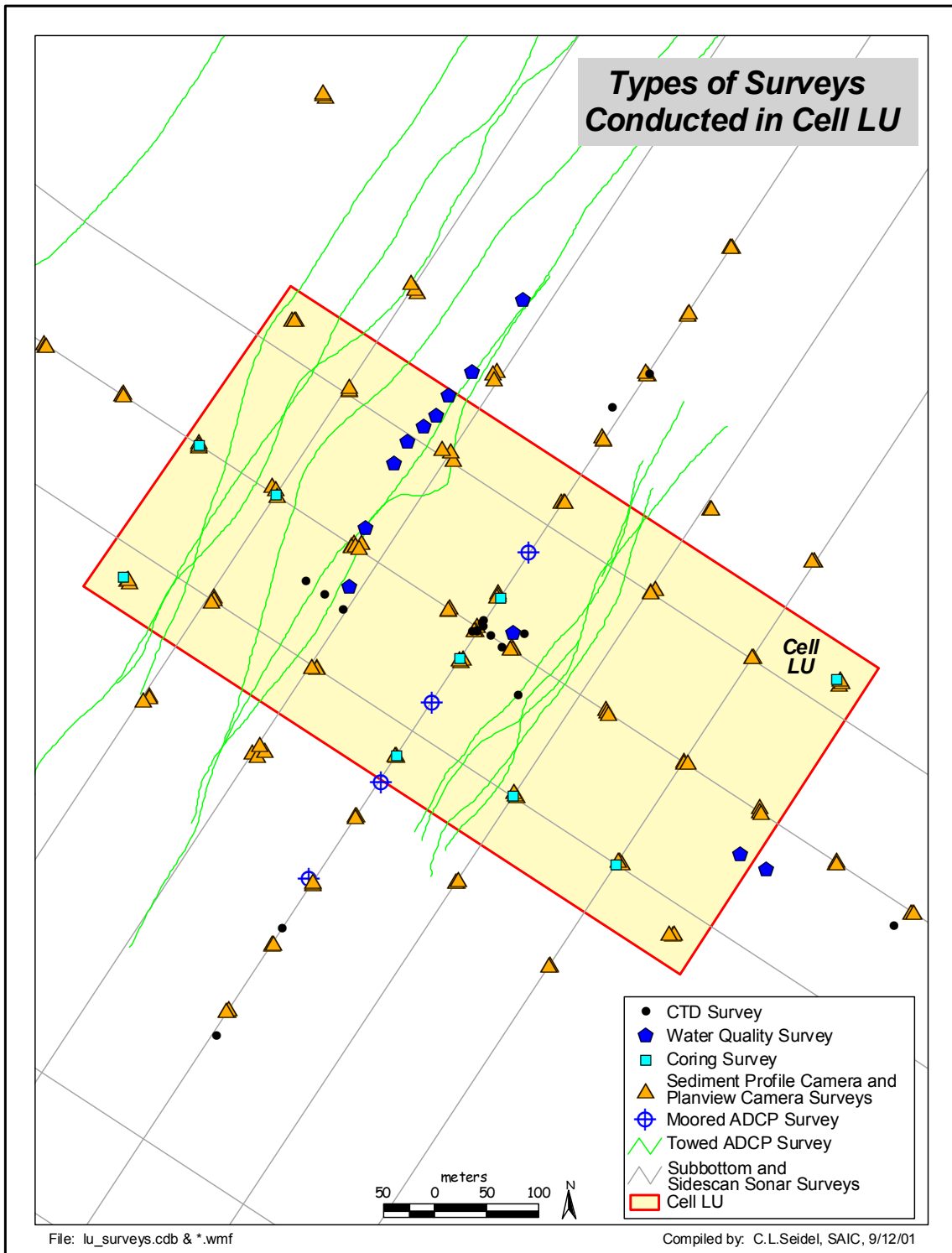

Figure 3-7. Composite graphic showing distribution of survey positions around Cell LU. Straight lines show the sub-bottom sediment profile and side-scan sonar tracks. Wavy lines show towed ADCP tracks during plume monitoring. Symbols indicate locations of bottom quadrapods, samples collected from the water column during plume tracking, and seafloor sample collection positions following cap placement events

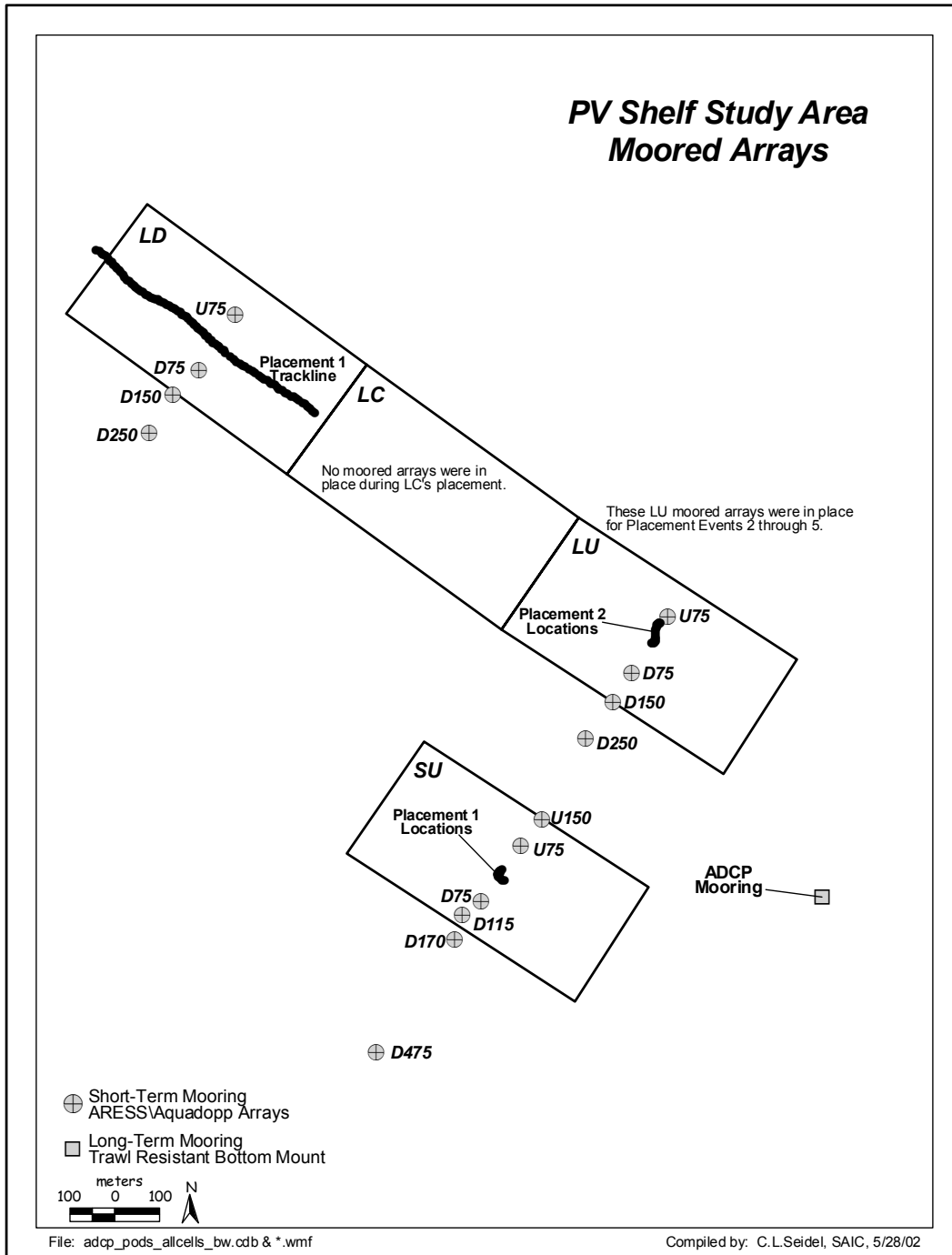

Figure 3-8. Composite graphic of bottom array placement locations at Cells LU, SU, and LD. Also shown are first placement locations of cap sediments during time arrays were deployed

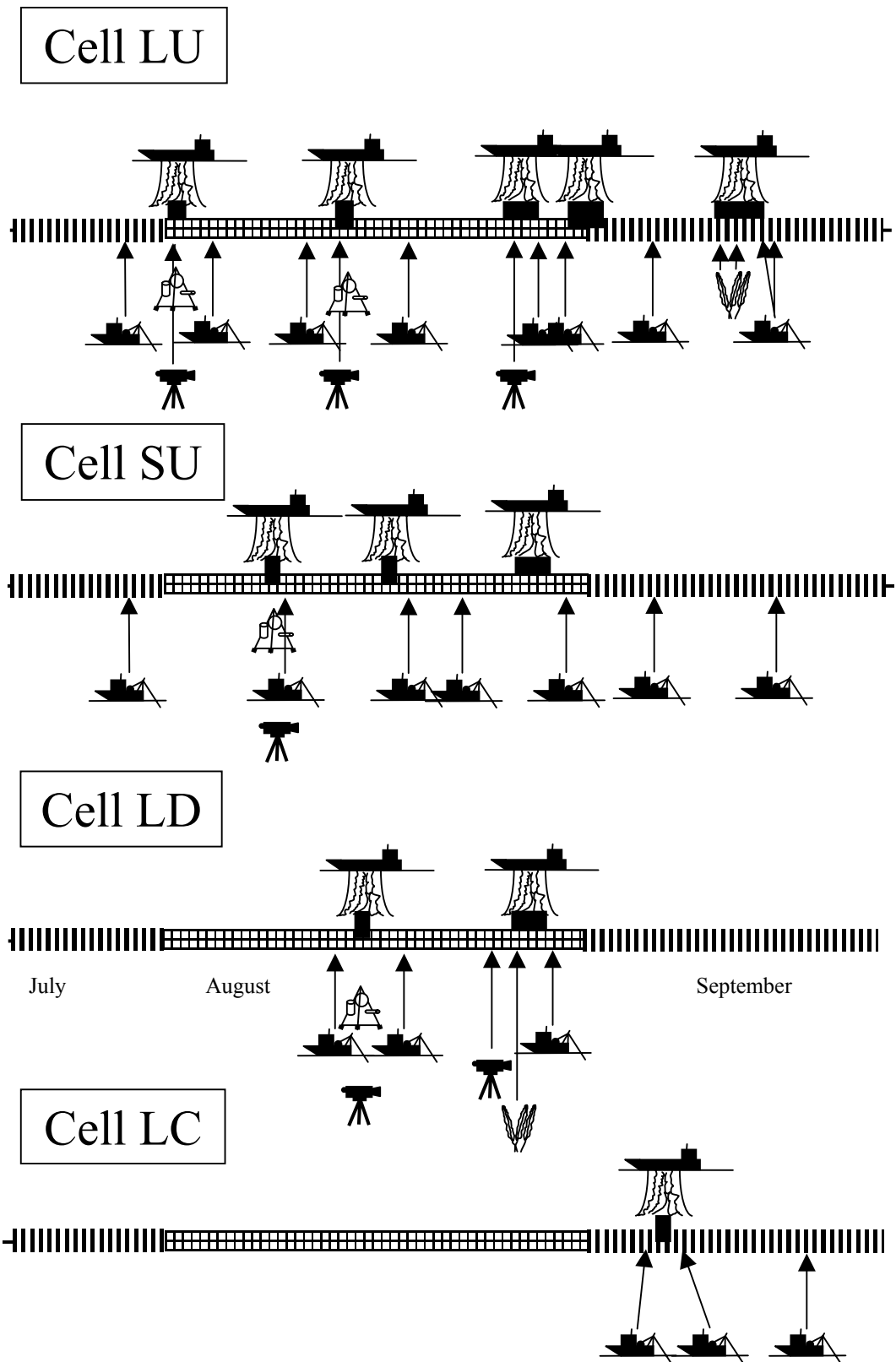

Figure 3-9. Composite time line of capping and monitoring activities during summer 2000 pilot capping. See following figures for detailed explanation of symbols

Cell LU

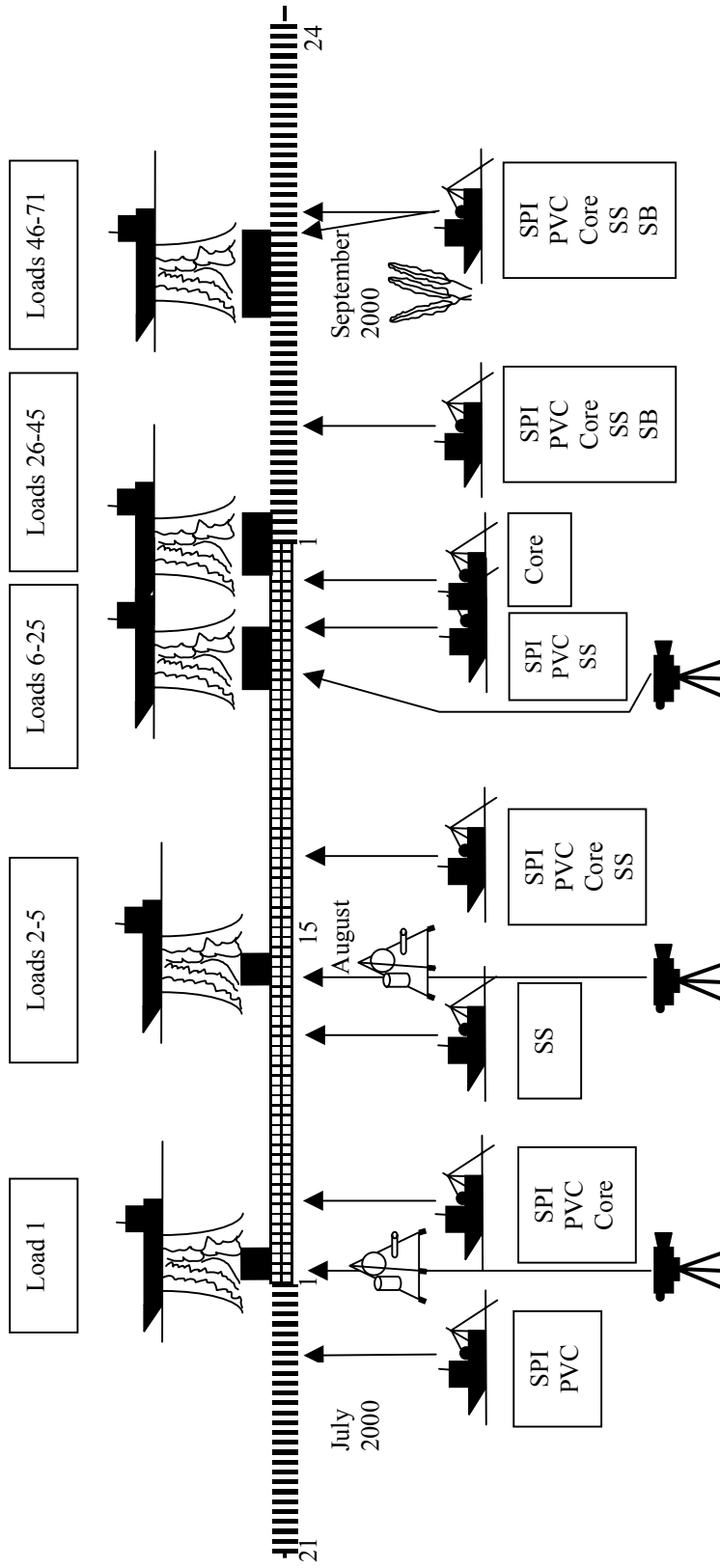

Figure 3-10. Activities time line for Cell LU 21 July 2000-24 September 2000. Cap placement activities are indicated by dredge symbol and solid bar. Monitoring activities are shown by monitoring vessel, current meter tripod, video camera, and help symbols. Monitoring activity codes associated with monitoring vessel symbol are SPI-Sediment Profile Imaging, PVC-Plan View camera, Core-Coring survey, SS-Side Scan, SB-Sub-bottom profiling. Activities associated with the tripod include bottom arrays, plume tracking, and plume water quality sampling

Cell SU

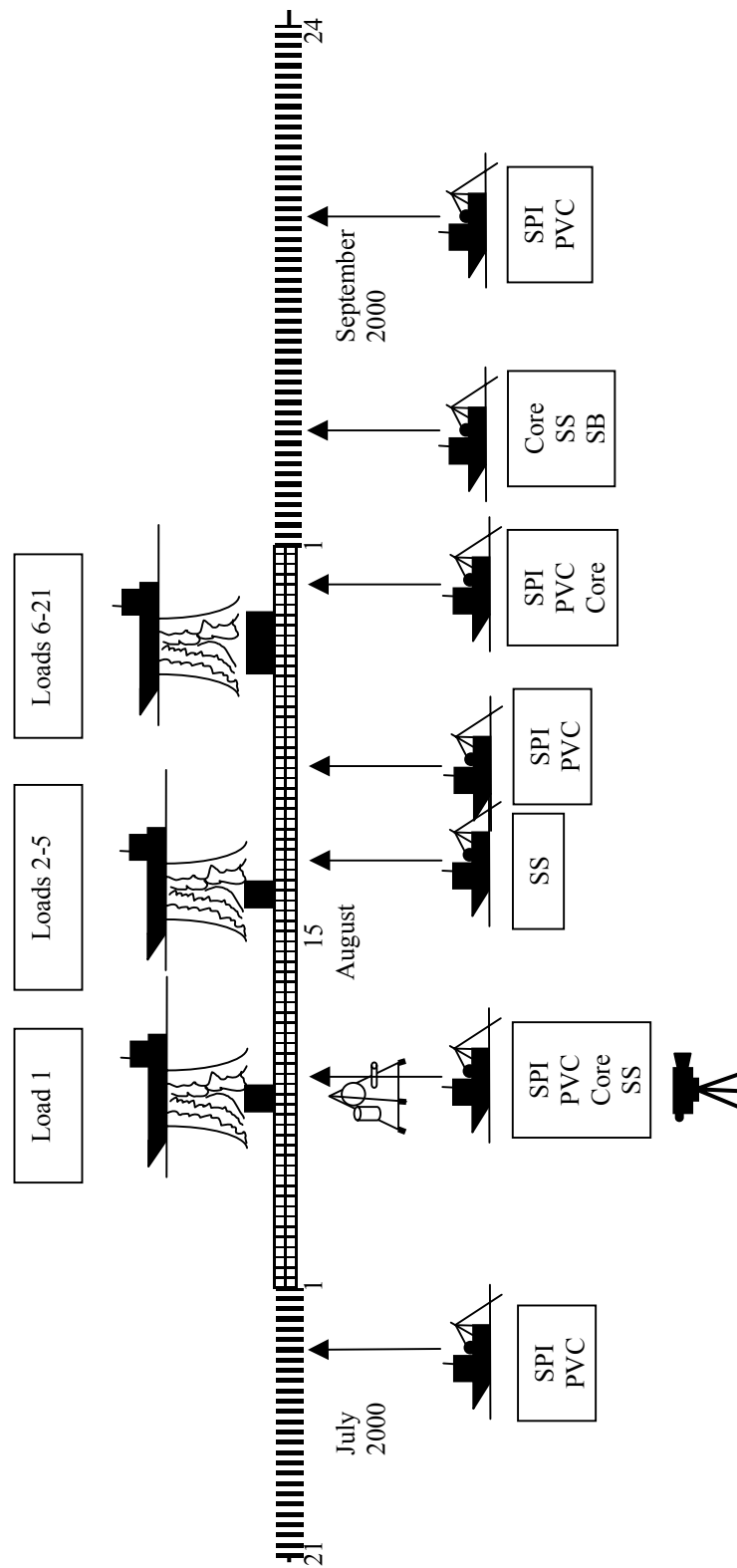

Figure 3-11. Activities time line for Cell SU 21 July 2000-24 September 2000. Cap placement activities are indicated by dredge symbol and solid bar. Monitoring activities are shown by monitoring vessel, current meter tripod, and video camera symbols. Monitoring activity codes associated with the monitoring vessel symbol are SPI-Sediment Profile Imaging, PVC-Plan View camera, Core-Coring survey, SS-Side Scan, SB-Sub-bottom profiling. Activities associated with tripod include bottom arrays, plume tracking, and plume water quality sampling

Cell LD

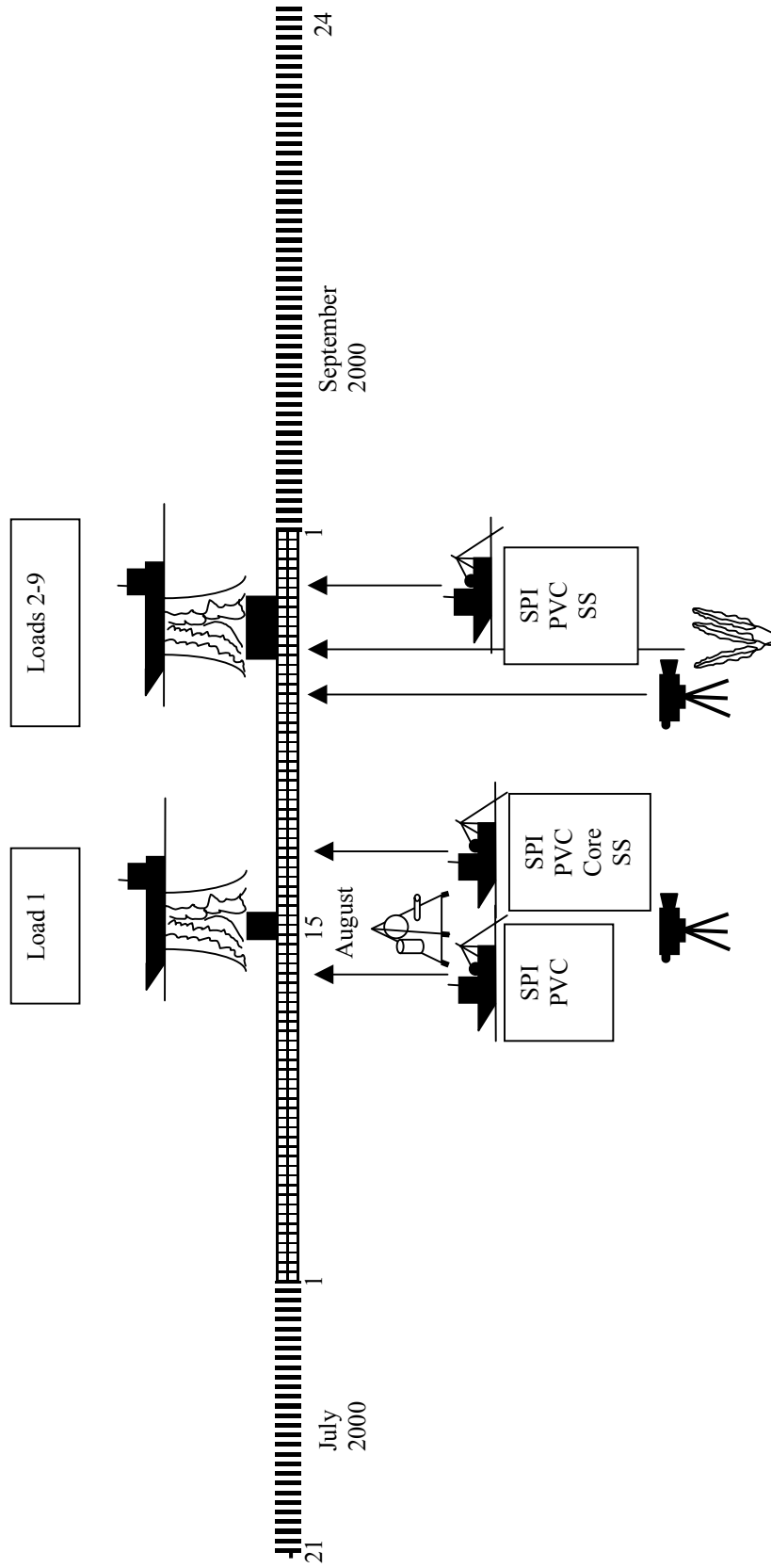

Figure 3-12. Activities time line for Cell LD 21 July 2000-24 September 2000. Cap placement activities are indicated by dredge symbol and solid bar. Monitoring activities are shown by monitoring vessel, current meter tripod, video camera, and kelp symbols. Monitoring activity codes associated with monitoring vessel symbol are SPI-Sediment Profile Imaging, PVC-Plan View camera, Core-Coring survey, and SS-Side Scan. Activities associated with the tripod include bottom arrays, plume tracking, and plume water quality sampling

Cell LC

3-62

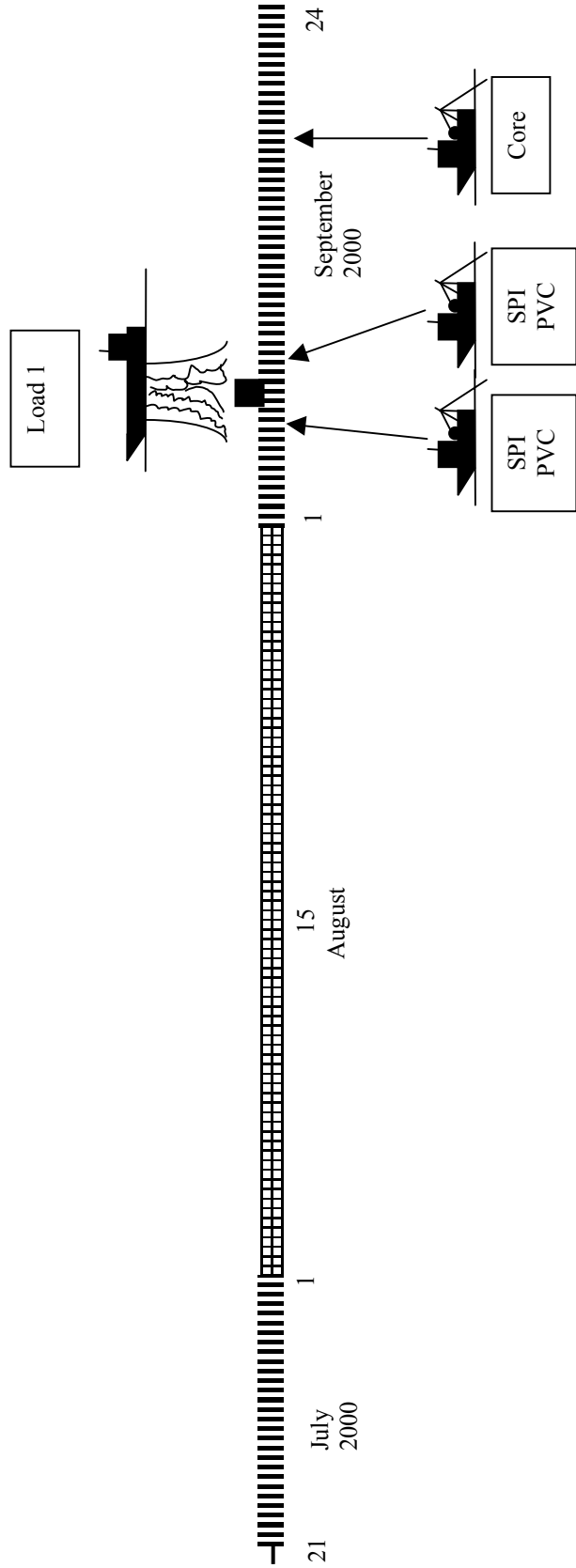

Figure 3-13. Activities time line for Cell LC 21 July 2000-24 September 2000. Cap placement activity is indicated by the dredge symbol and solid bar. Monitoring activities are shown by monitoring vessel. Monitoring activity codes associated with the monitoring vessel symbol are SPI-Sediment Profile Imaging, PVC-Plan View camera, Core-Coring survey

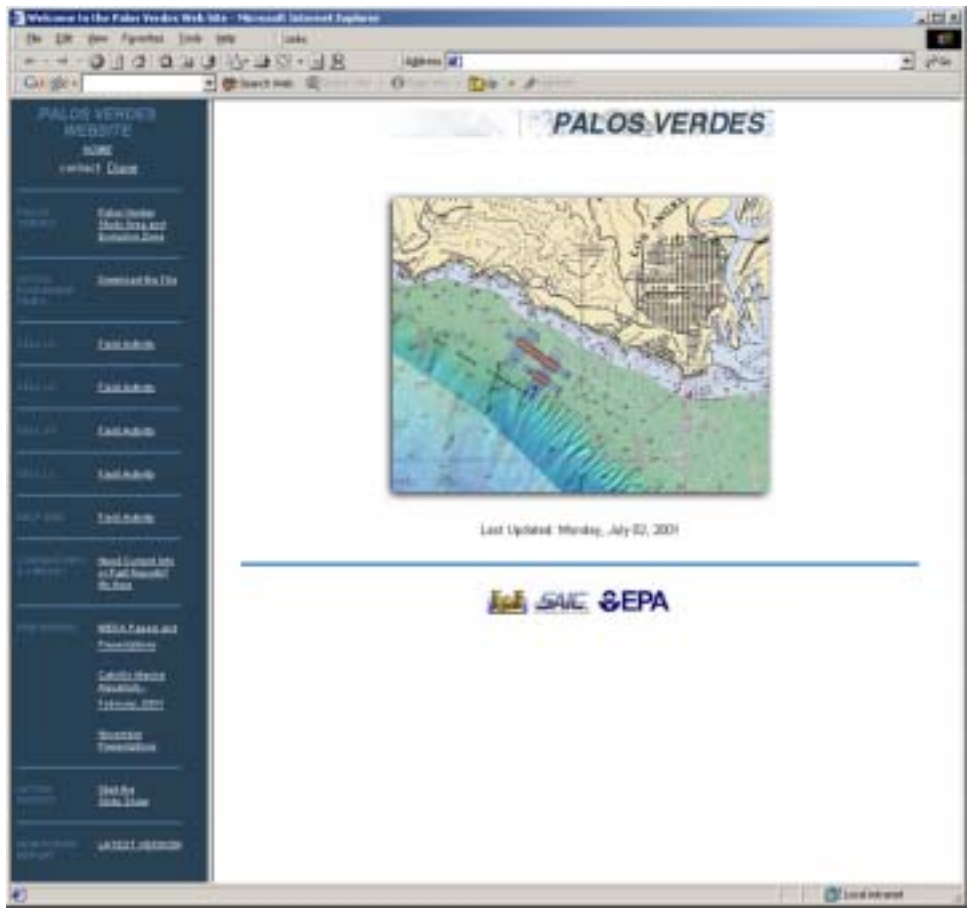

Figure 3-14. Contents page of the Palos Verdes Web site illustrating type of information that was available to project team



Figure 3-15. Navigator and DGPS navigation related equipment aboard one of survey vessels. The DGPS equipment was linked to laptop computer for visual real-time display of vessel position and target sample locations

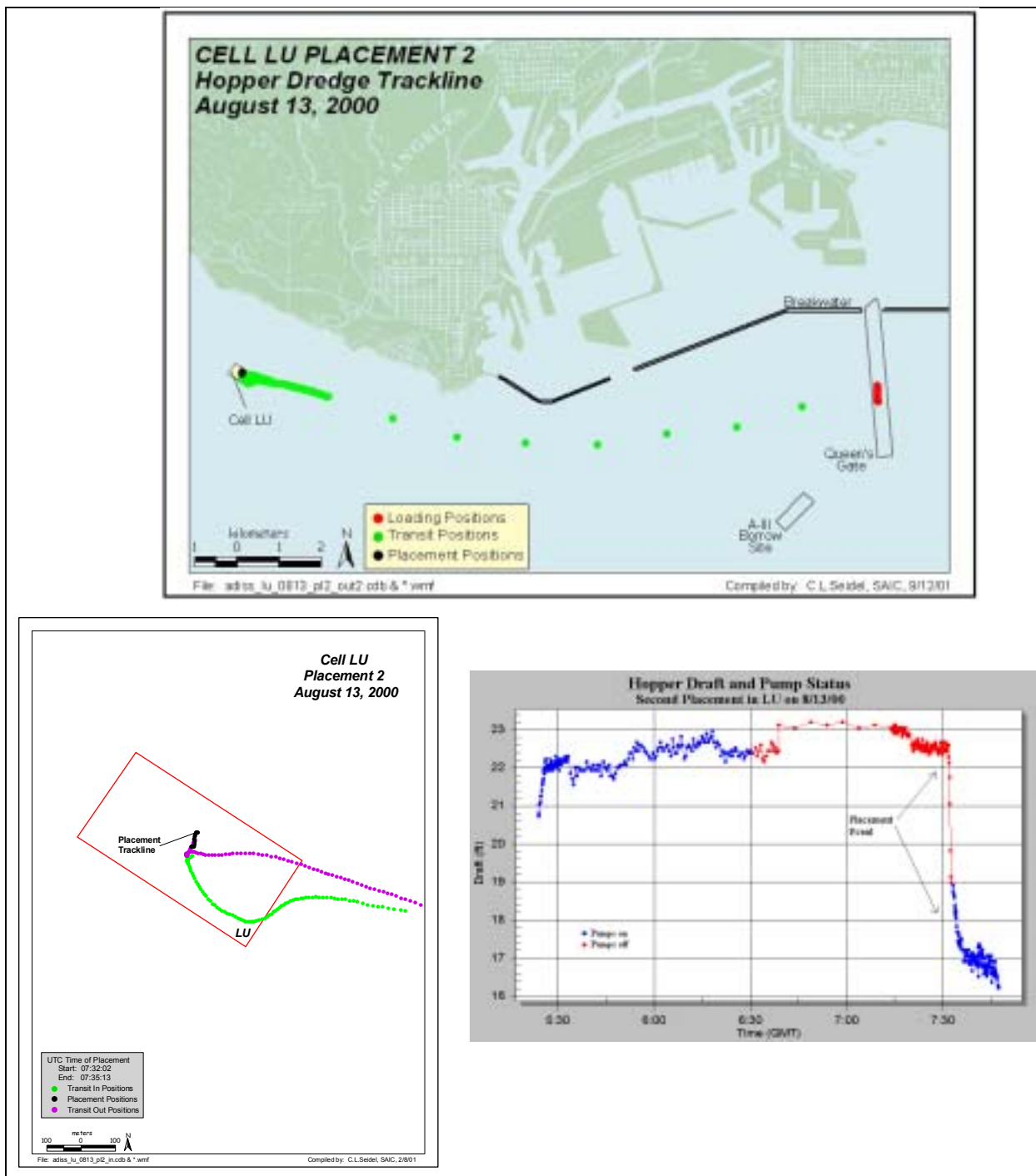

Figure 3-16. Example of dredge tracking information collected by Automated Disposal Surveillance System (ADISS). Top graphic shows the loading, transit, and placement positions. Left graphic shows detailed position during placement and right graphic shows time series of hopper draft during sequence



Figure 3-17. Retrieval of grab sample from hopper bin of dredge *Sugar Island*



Figure 3-18. Acoustic Doppler Current Profiler (ADCP) towfish on deck of *MV Tuna*



Figure 3-19. Deployment of drogue from *MV Tuna* in plume behind *Sugar Island*

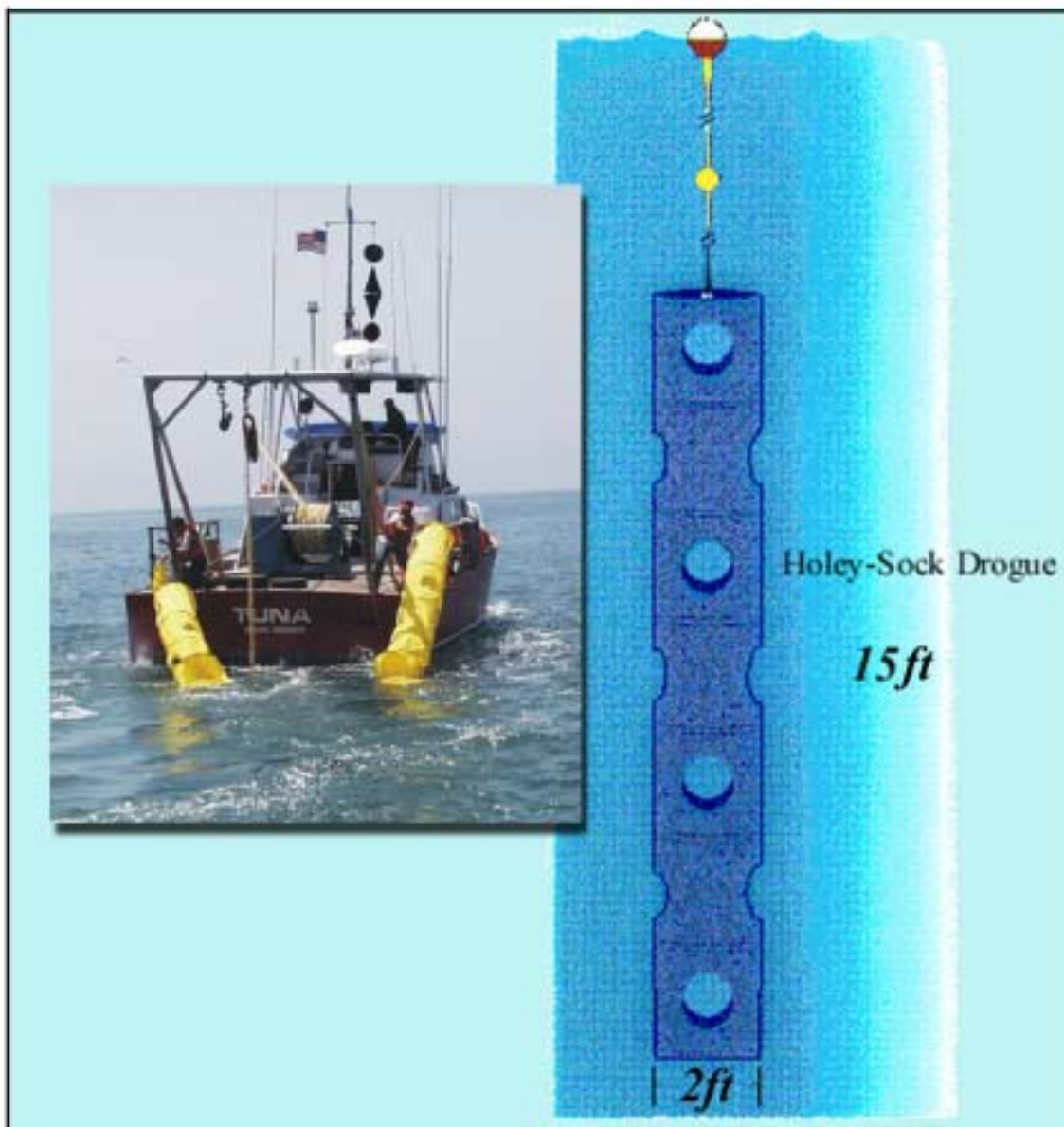

Figure 3-20. Schematic of holey-sock drogue used to track currents at different levels in water column with inset of deployment operations in plume



Figure 3-21. Rosette sampler used to collect water samples from plume and conductivity, temperature and depth (CTD) data

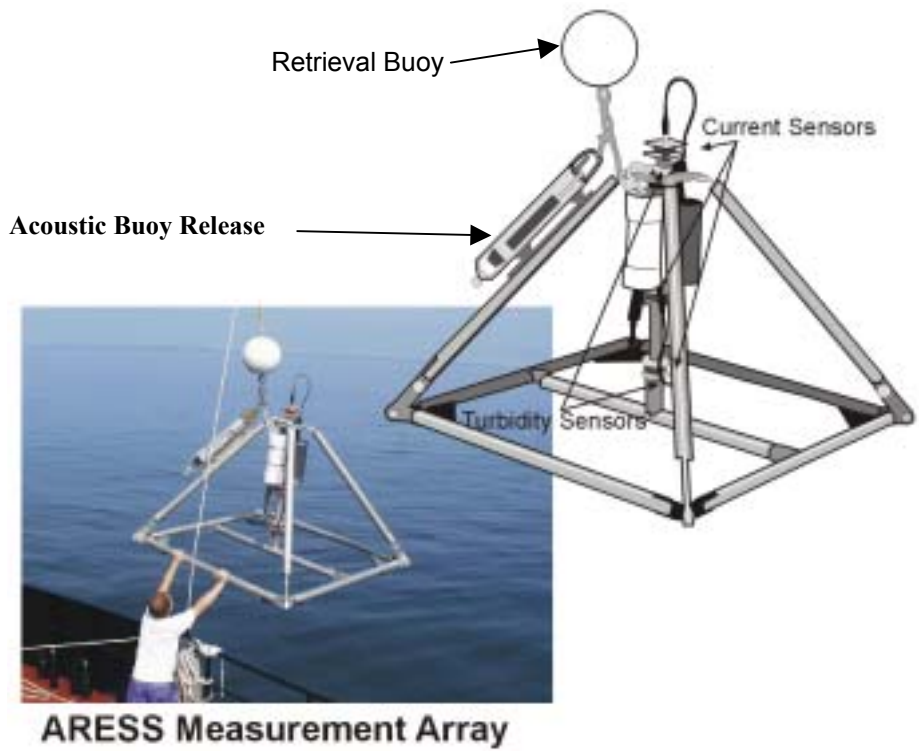

Figure 3-22. ARESS Oceanographic instrument array quadrupod



Figure 3-23. Video camera frame on deck of *RV Sea World* prior to deployment

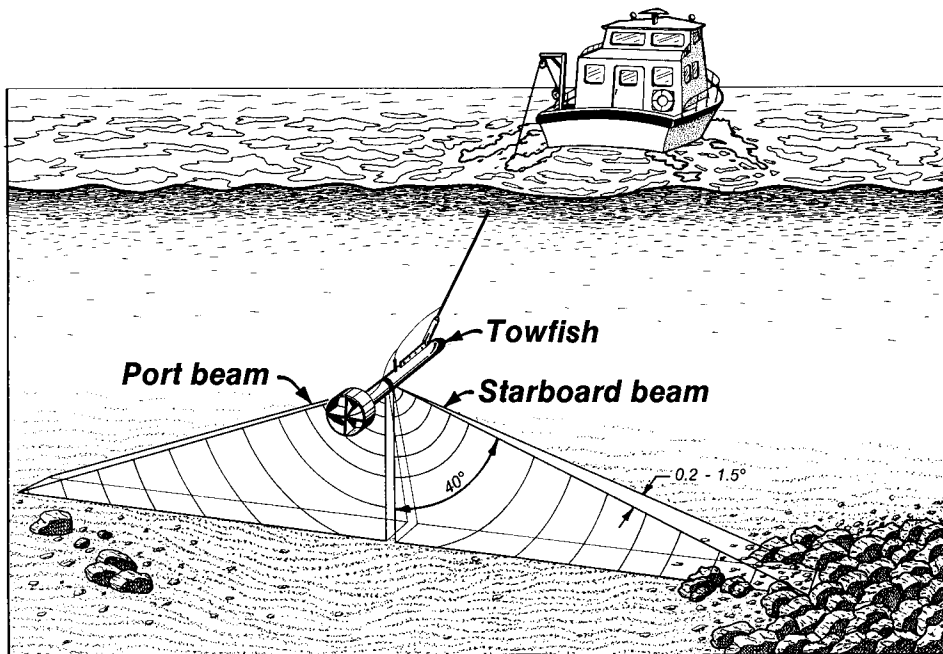

Figure 3-24. Schematic of side-scan sonar operations showing side-scan towfish and how area of seafloor on either side of instrument is scanned by sonar beams

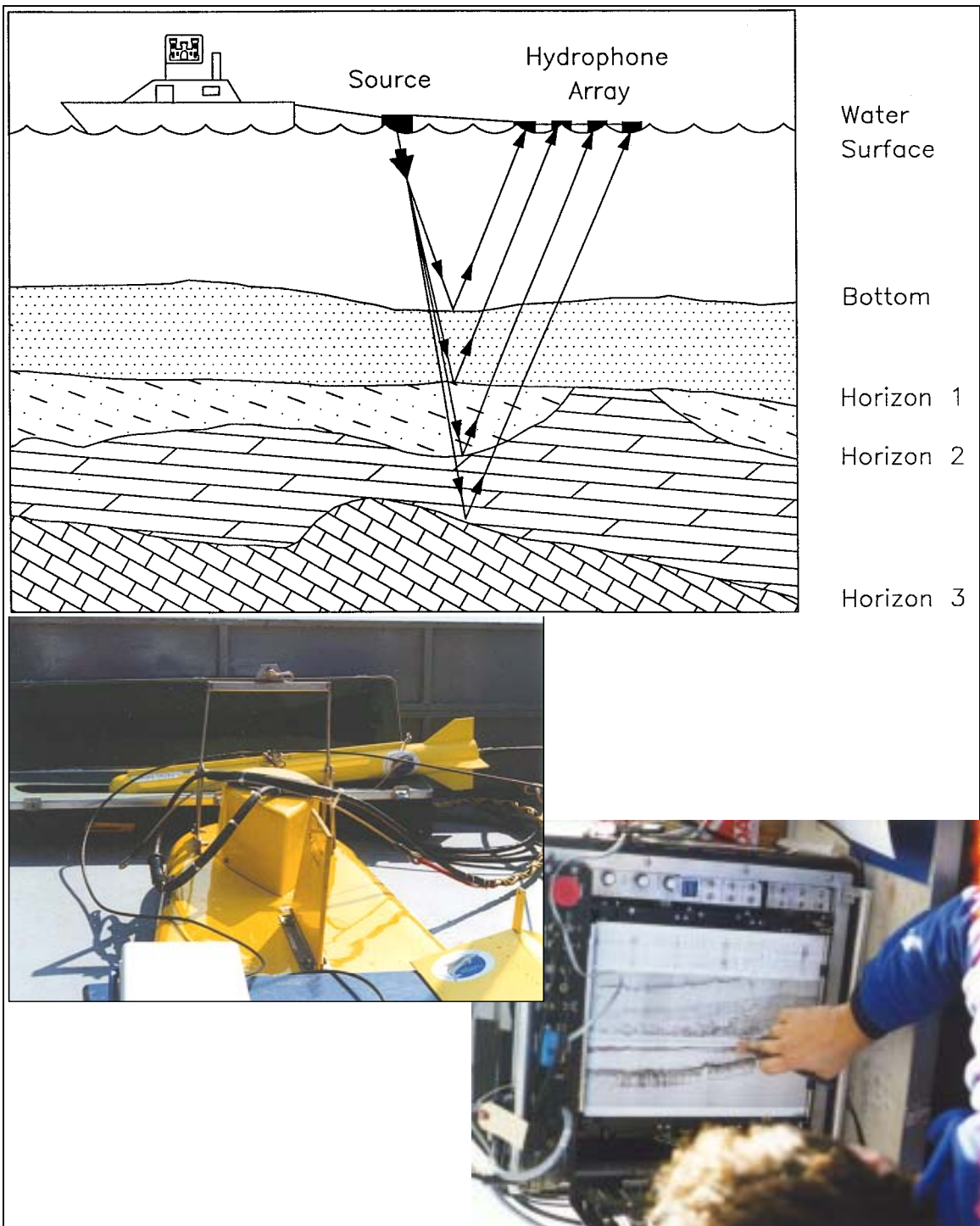

Figure. 3-25. Conceptual diagram of sub-bottom sediment profile operation along with photo (bottom left) of a sub-bottom fish in foreground (source) and example of sub-bottom recorder trace (bottom right)

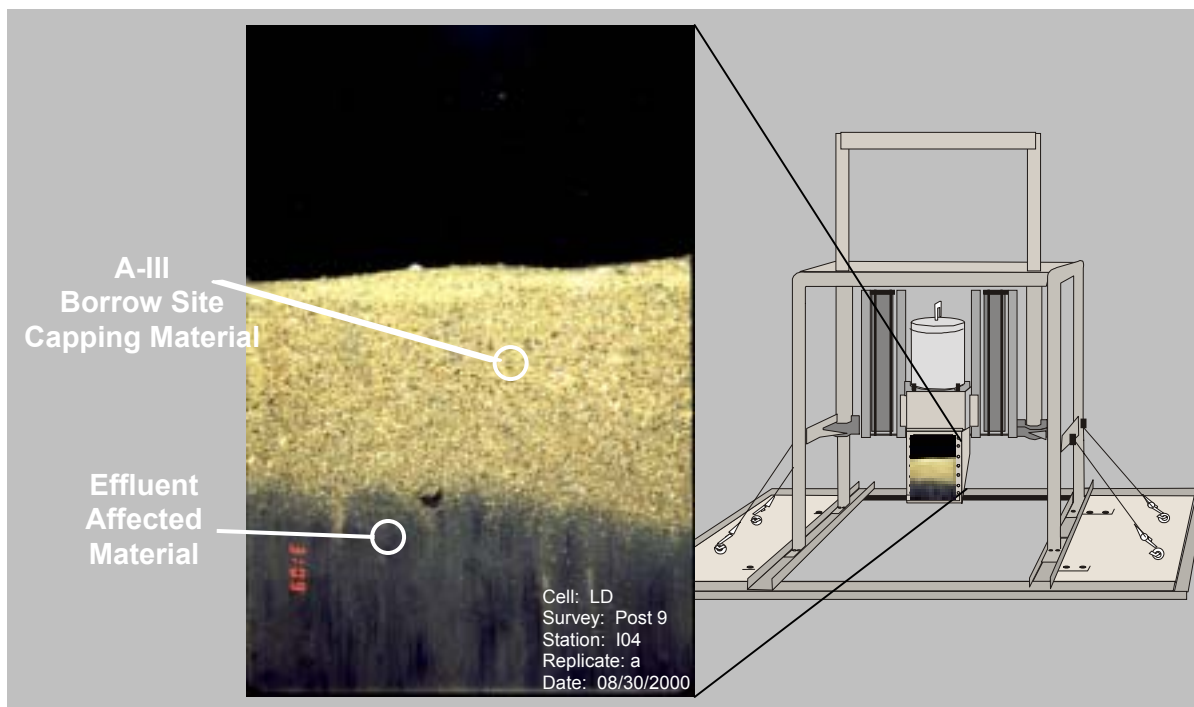

Figure 3-26. Schematic of sediment profile image (SPI) camera showing photo of profile down into sediment from Cell LD after placement of capping sand. Camera is able to photograph area 21 cm high by 15 cm wide. Plan view camera (PVC) was attached to frame of SPI camera so that it would take photograph before SPI touched seafloor

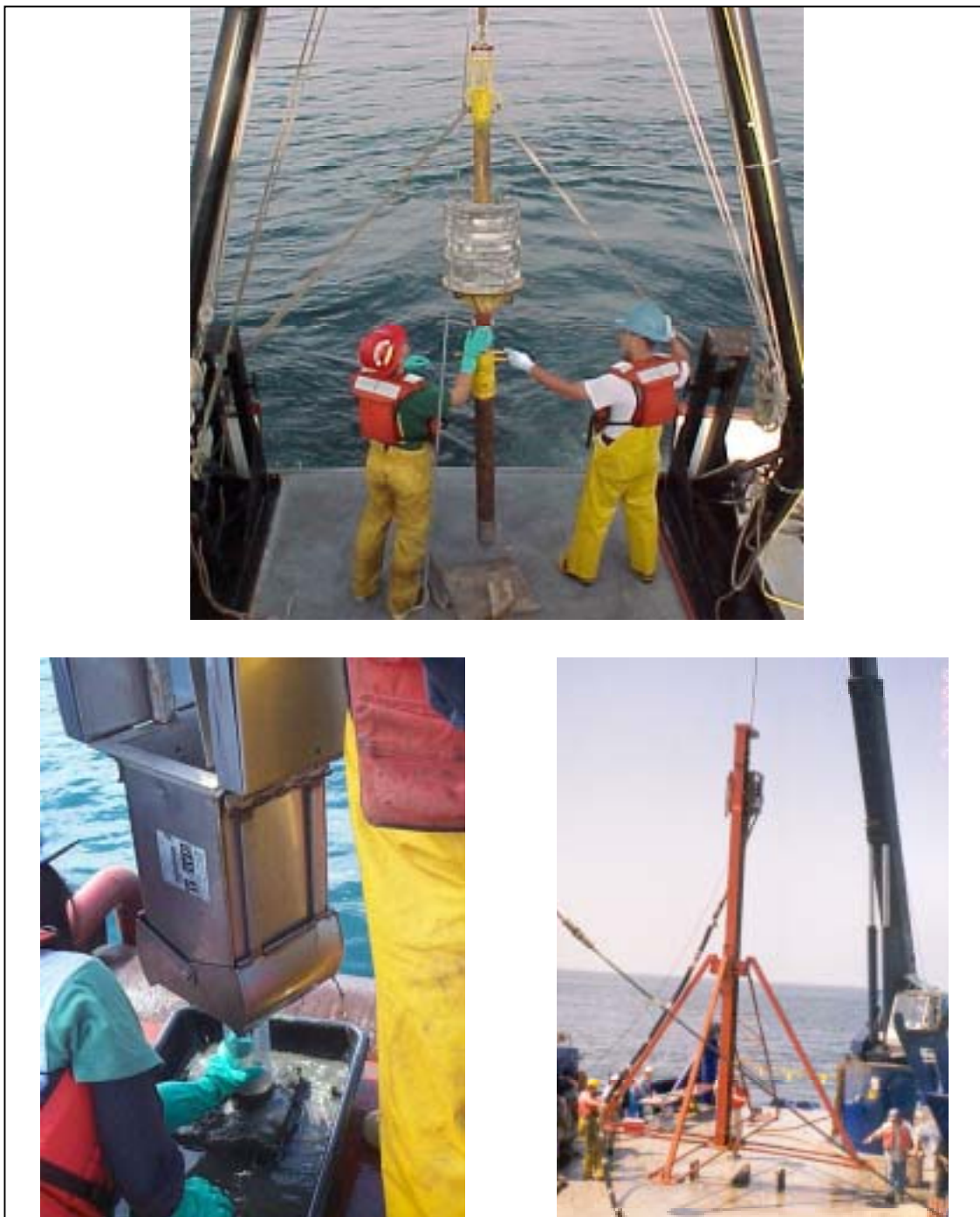

Figure 3-27. Types of coring equipment used for collecting sediment samples. Gravity corer (top), Gray-O'hara box corer (bottom left) and vibracorer (bottom right)

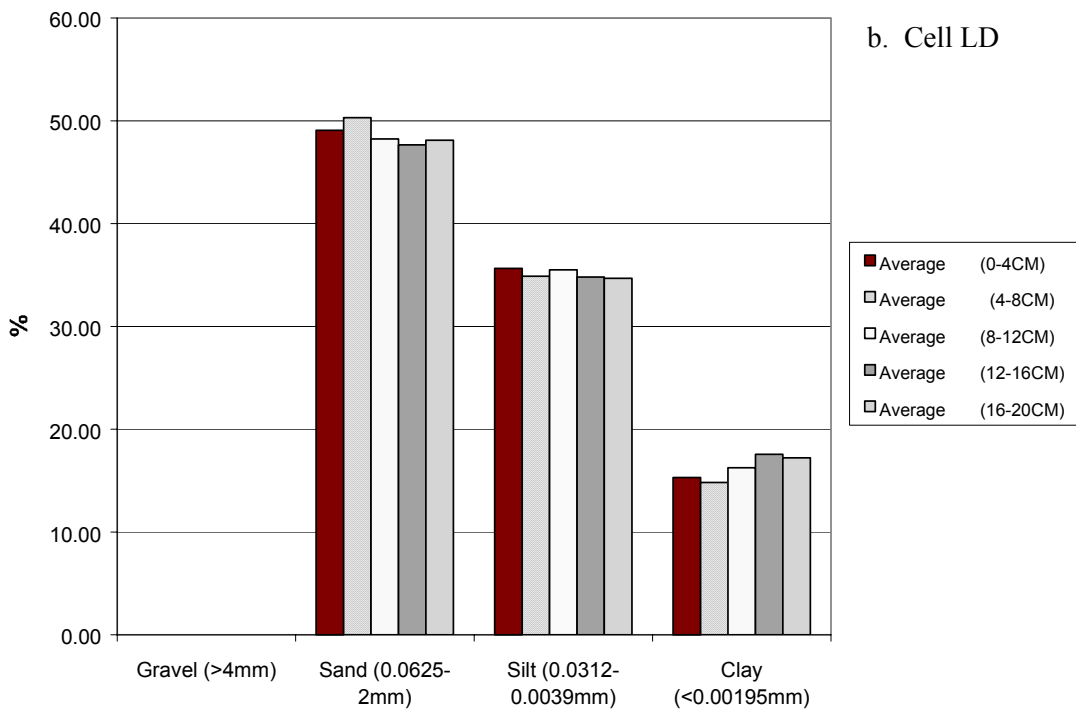
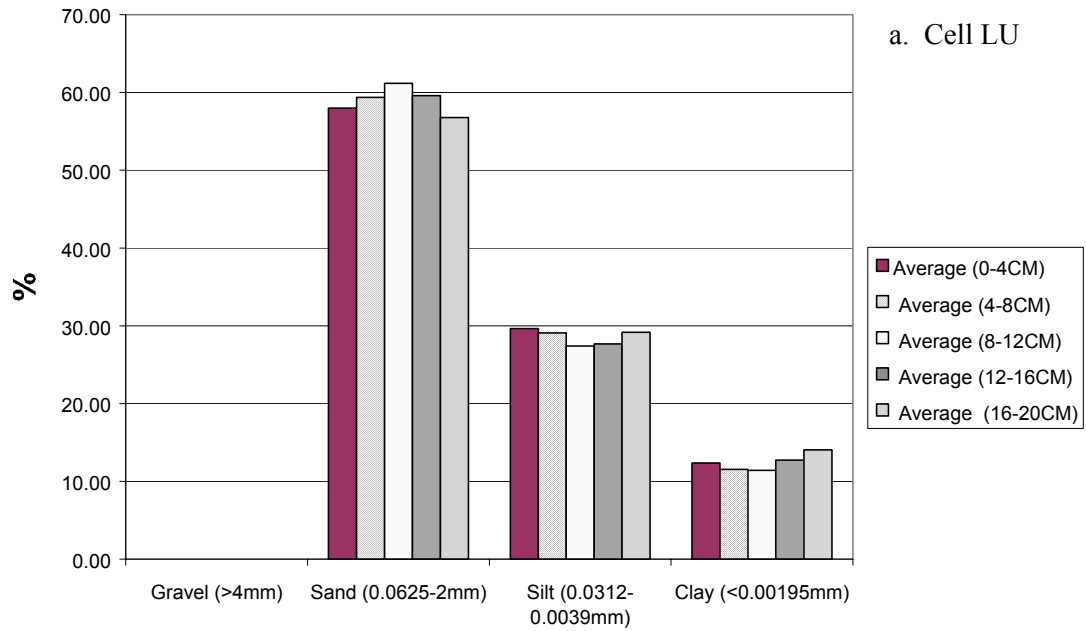

Figure 3-28. Down-core mean grain size distribution in baseline samples

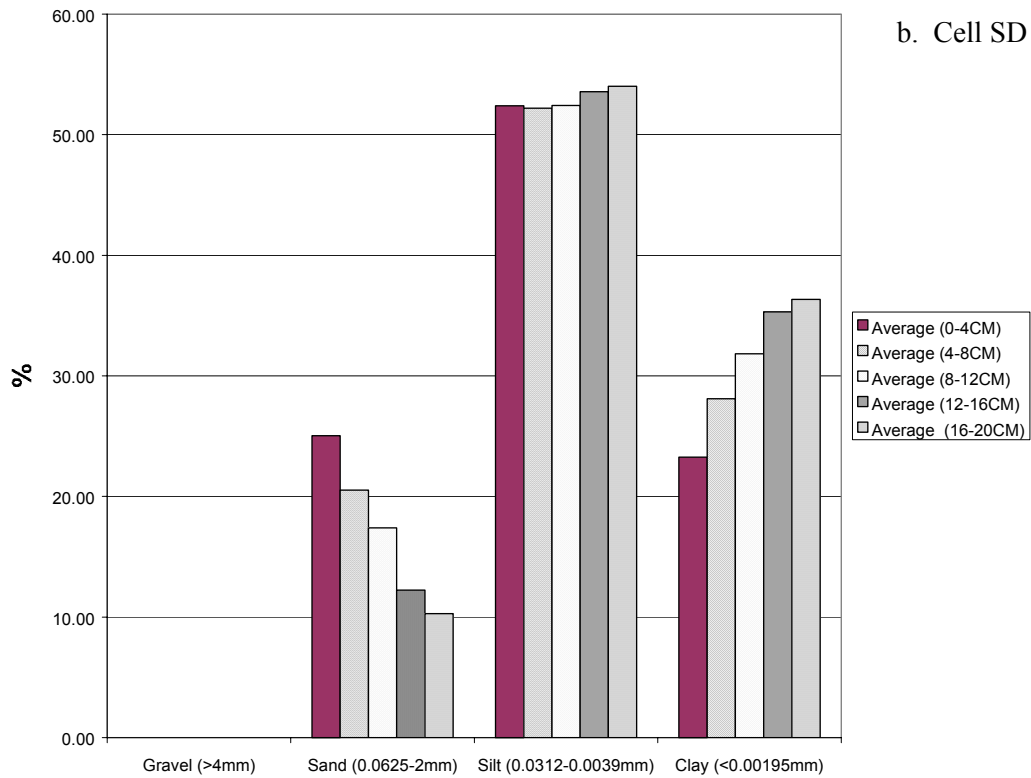
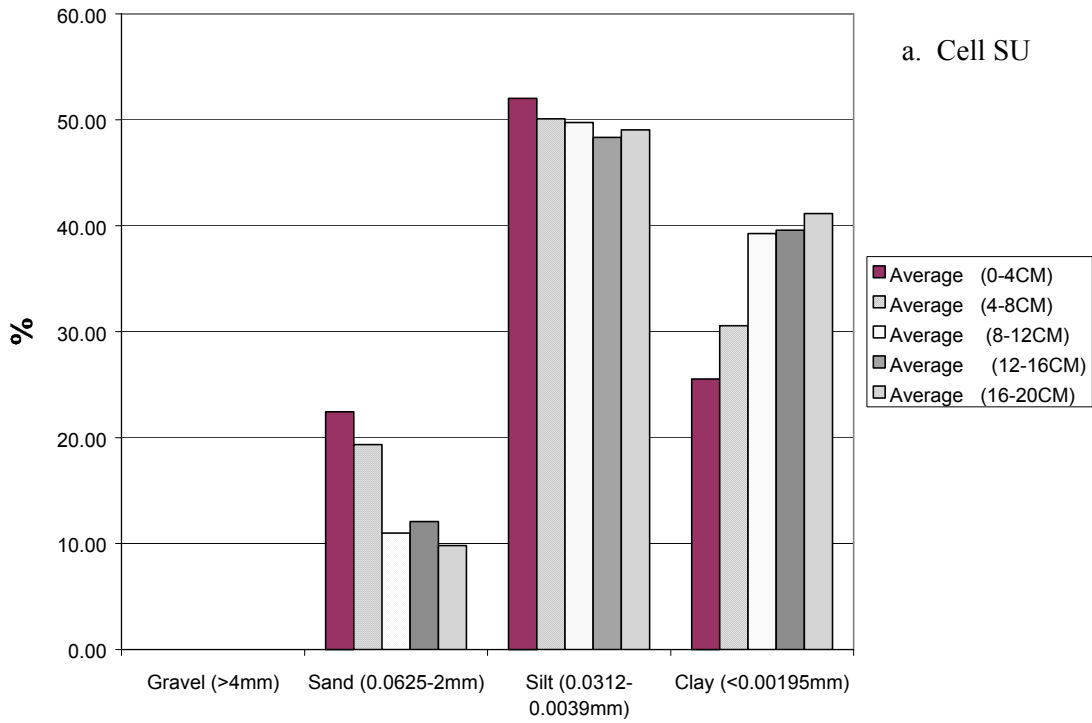

Figure 3-29. Down-core mean grain size distribution in baseline samples

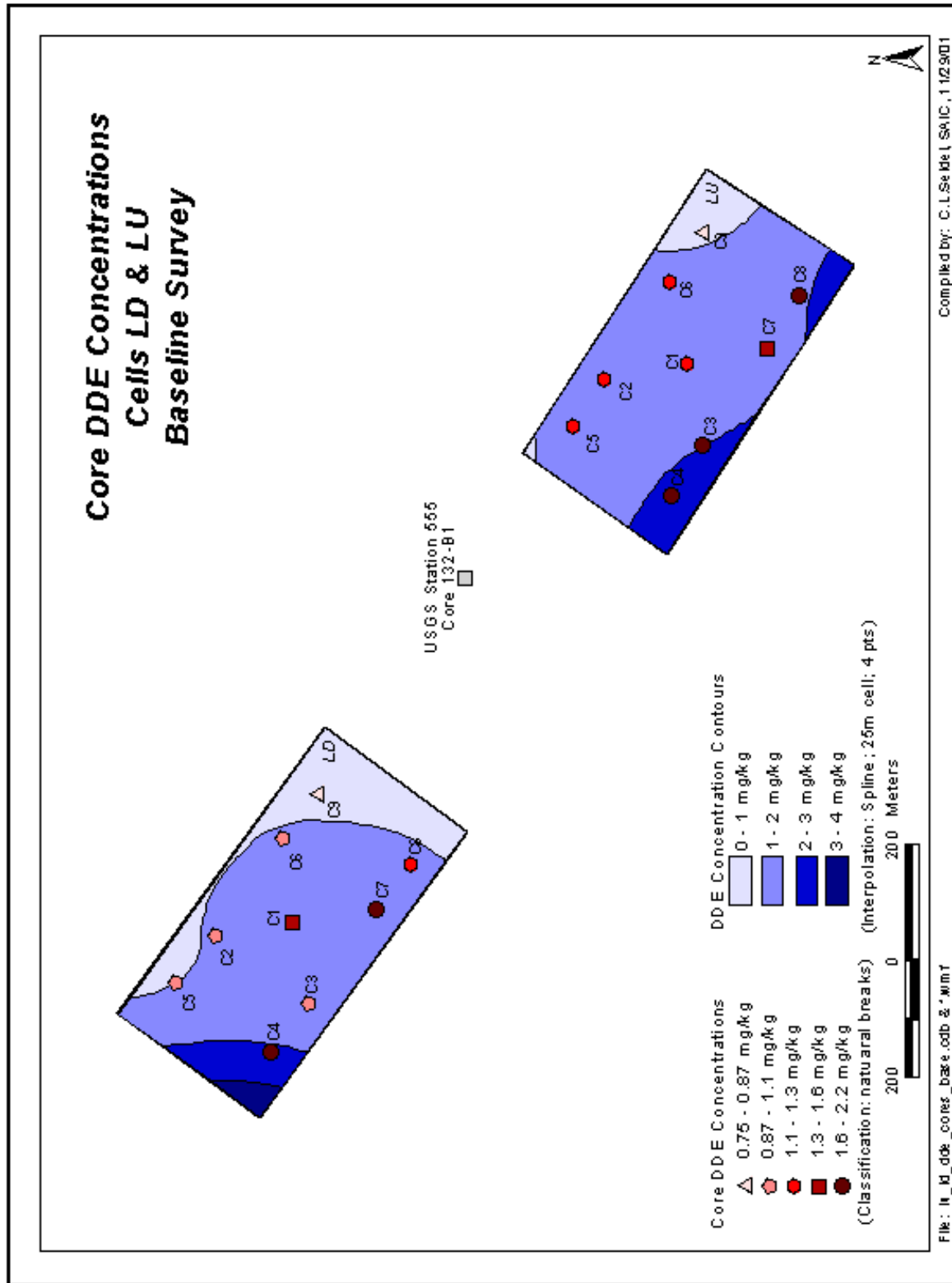

Figure 3-30. Baseline sediment surface DDE concentrations in Cells LD and LU and location of historical USGS station 555

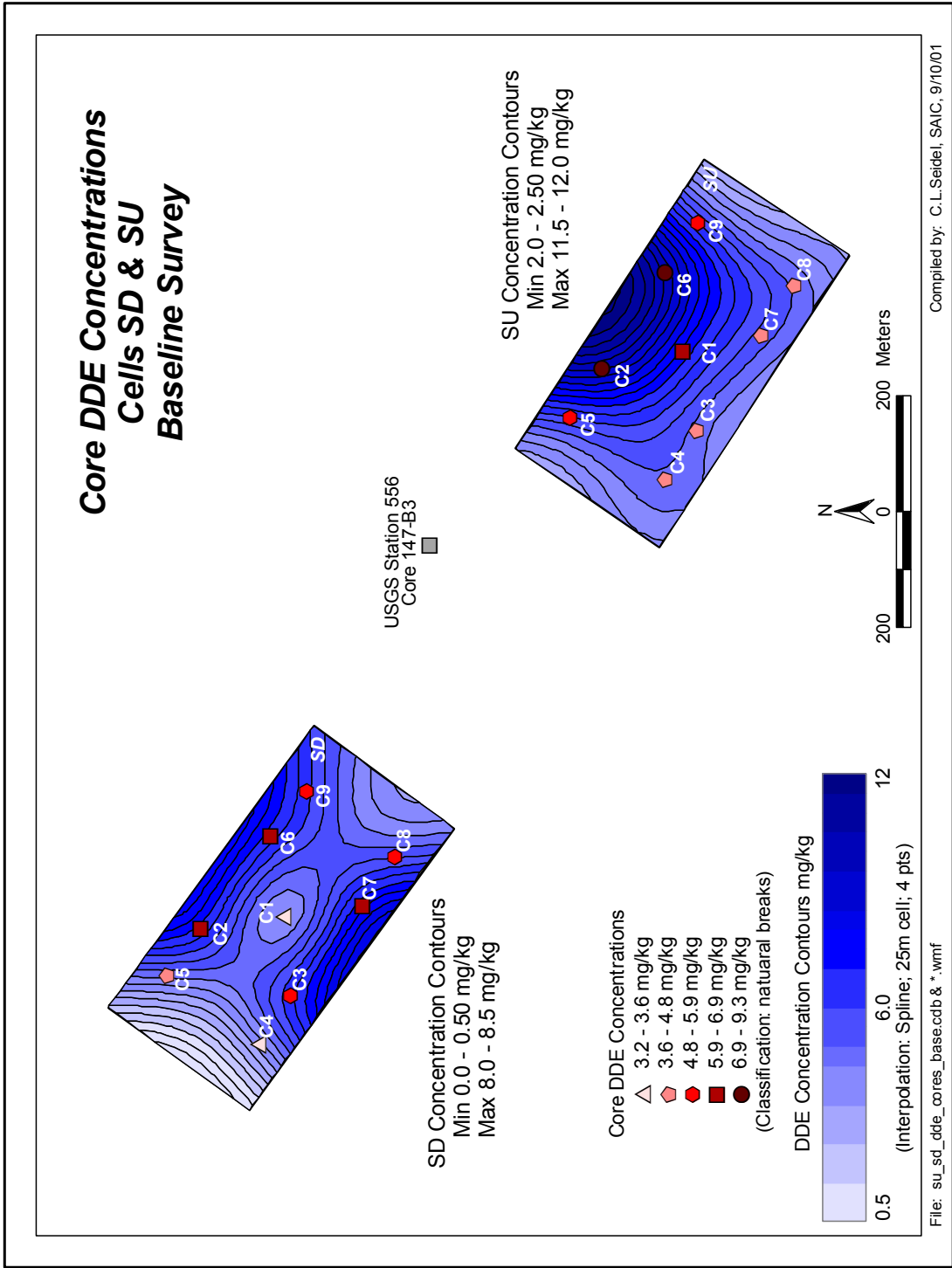

Figure 3-31. Baseline sediment surface DDE concentrations in Cells SD and SU and location of historical USGS station 556

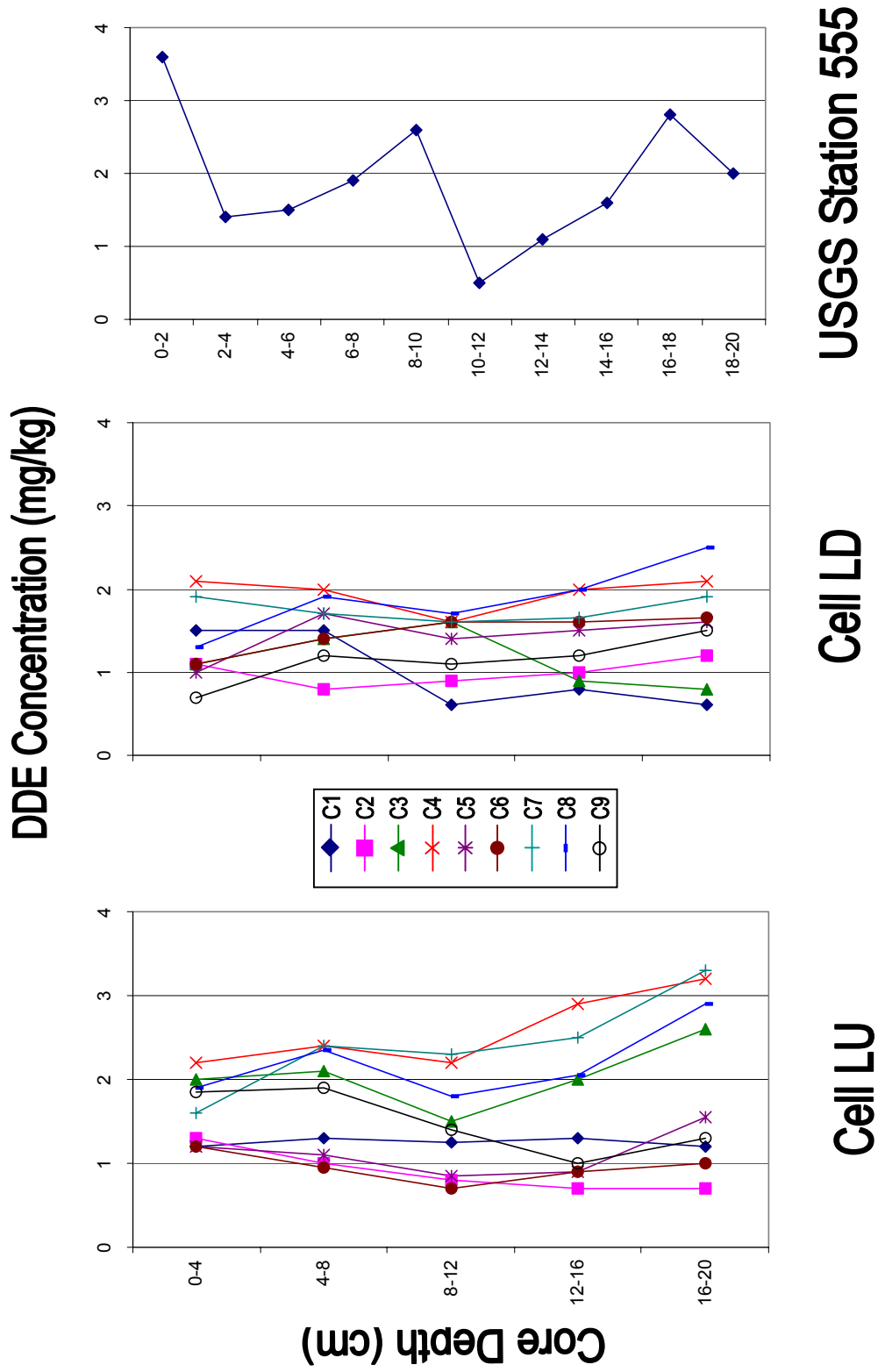

Figure 3-32. Baseline down-core concentrations of DDE in Cells LU and LD compared to historical USGS station 555

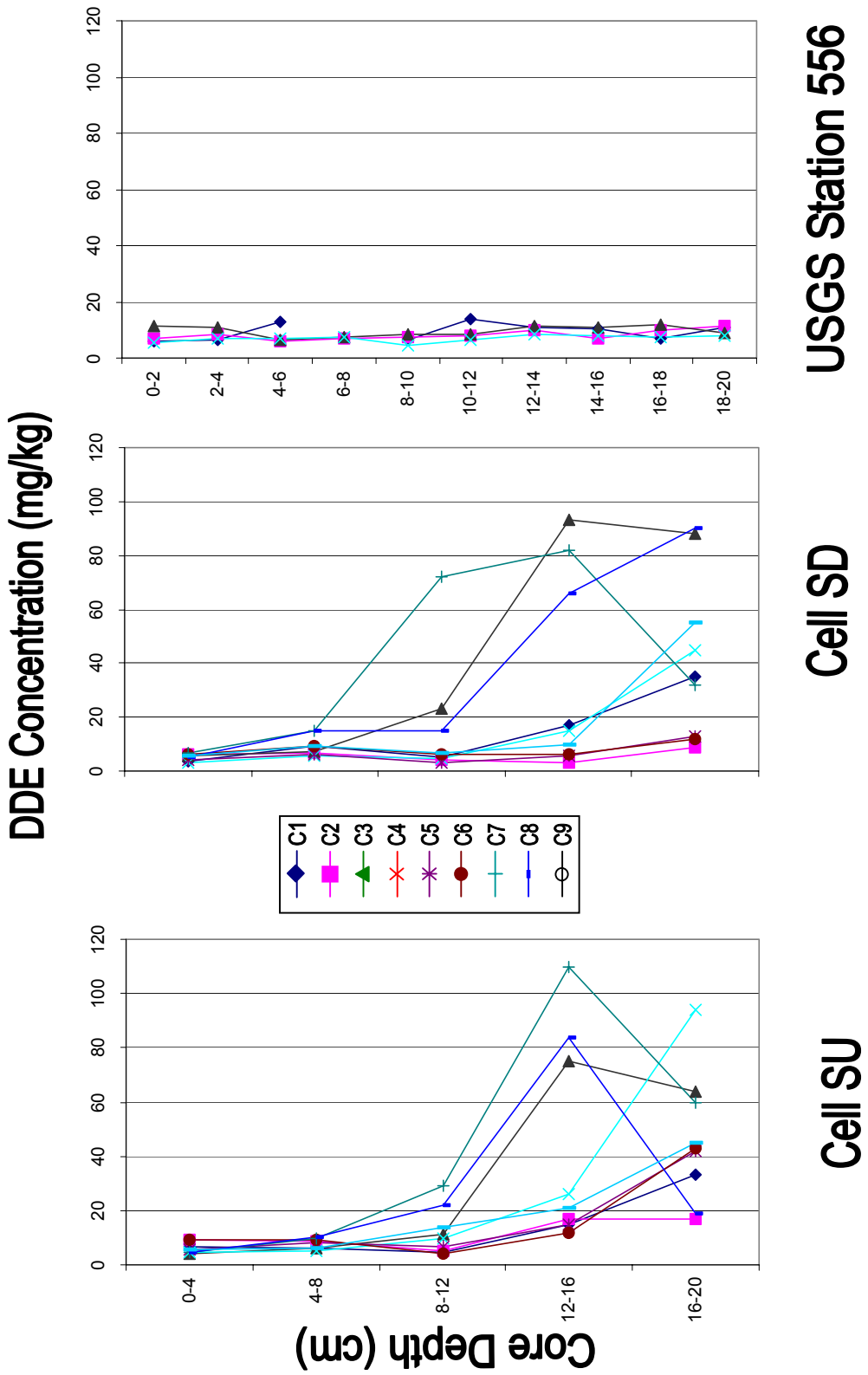

Figure 3-33. Baseline down-core concentrations of DDE in Cells SU and SD compared to historical USGS station 556



Figure 3-34. Comparison of representative SPI photos from landward (LUI11) and seaward cells (SUO24) showing difference in small scale topography resulting from biological burrowing activity

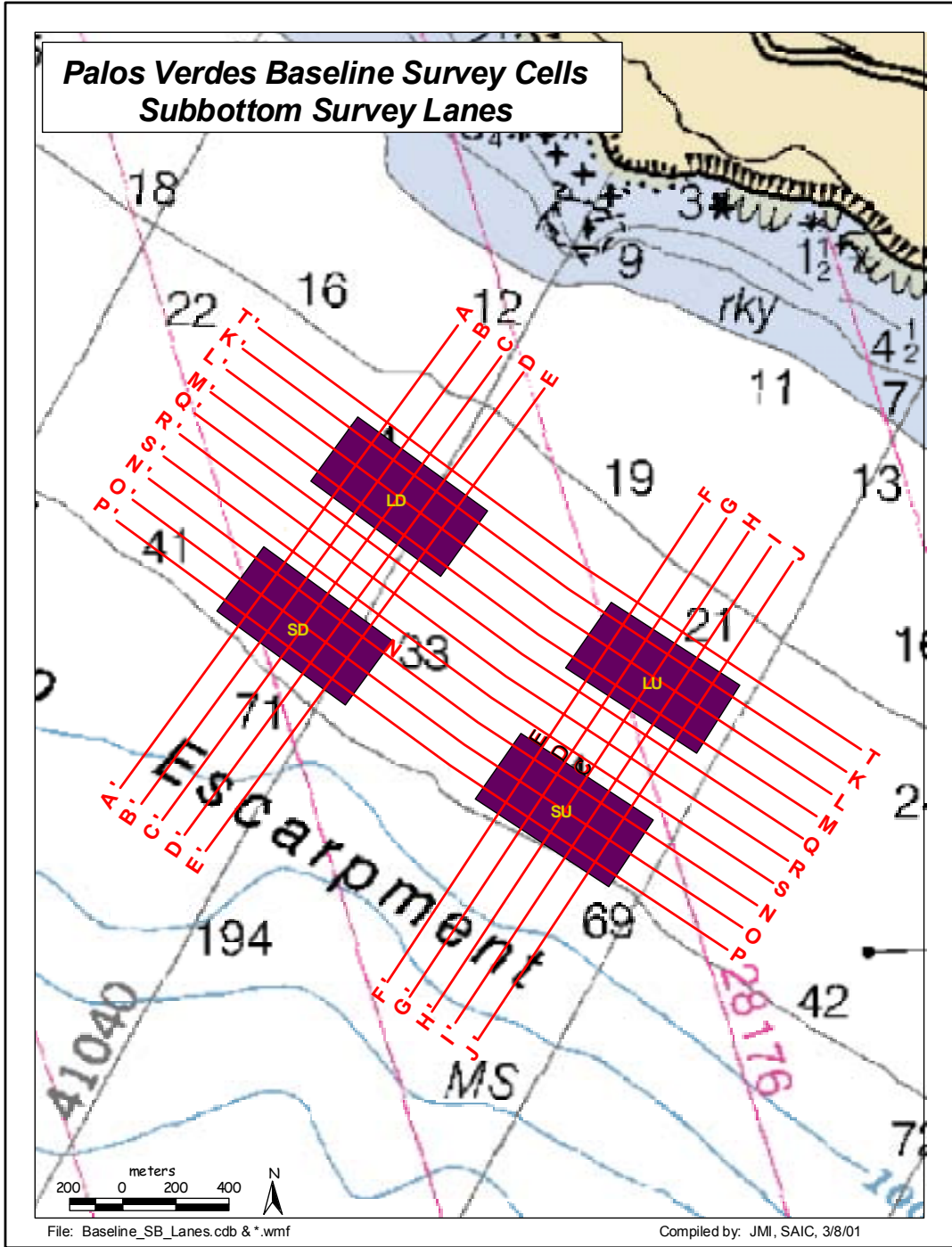

Figure 3-35. Sub-bottom sediment profile and side-scan sonar survey lanes conducted during baseline survey

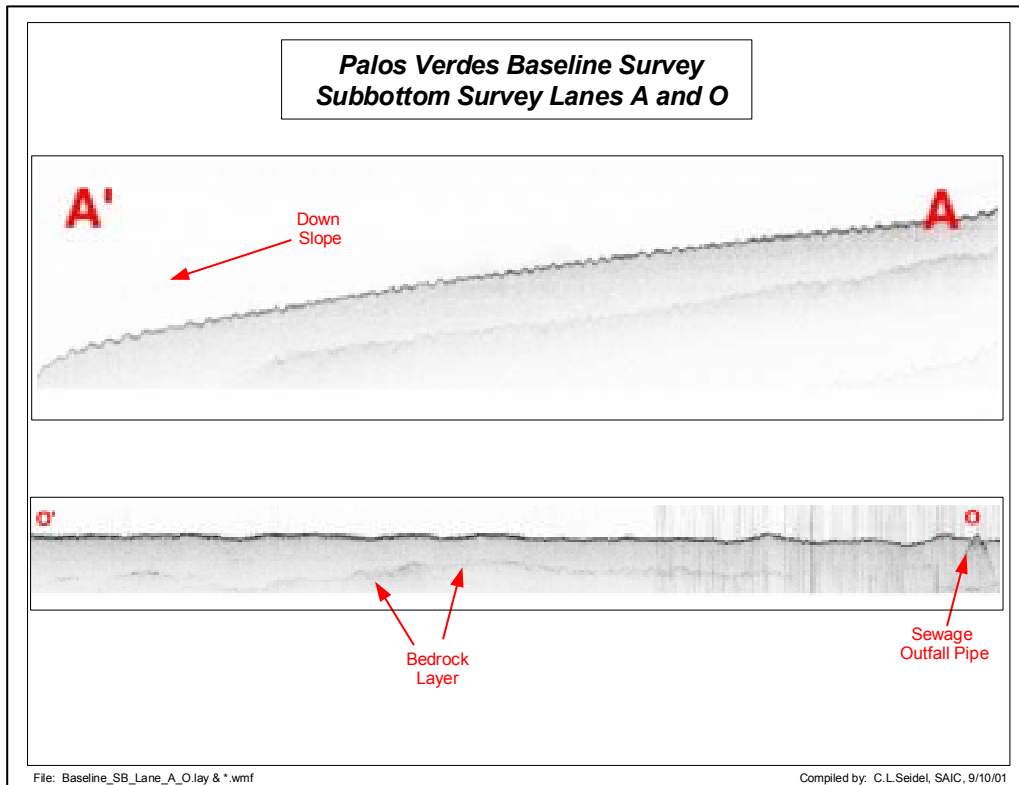

Figure 3-36. Examples of sub-bottom sediment profile survey data from baseline survey lanes A-A' and O-O'

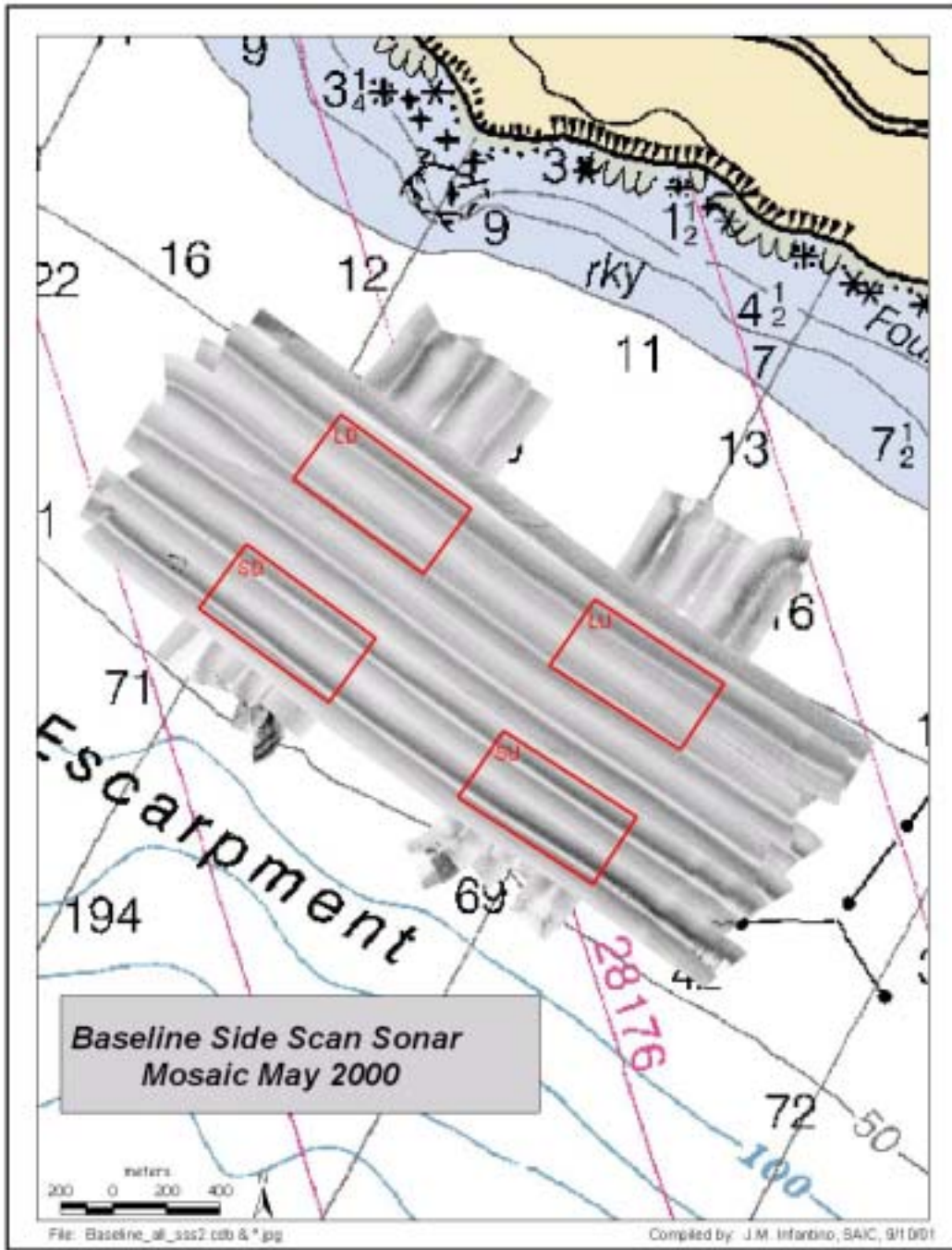

Figure 3-37. Baseline side-scan sonar mosaic showing relatively smooth, featureless seafloor

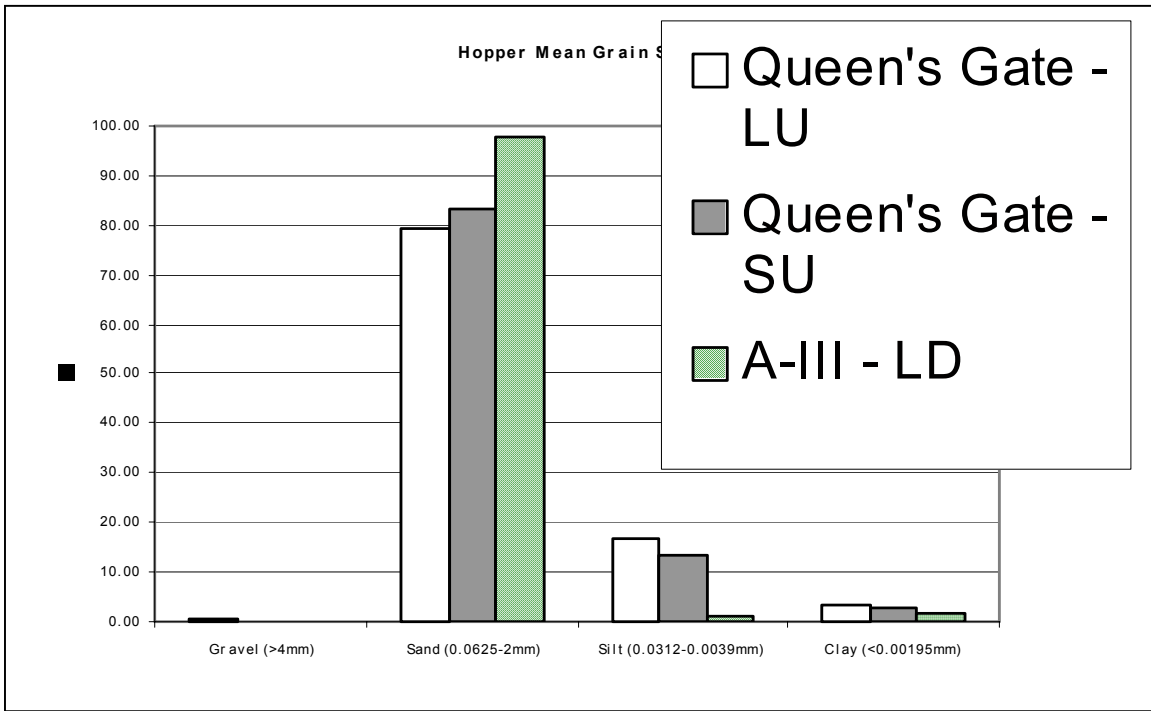

Figure 3-38. Hopper sample mean grain size distribution from Queen's Gate sediment (LU and SU) and the A-III borrow site (LD)

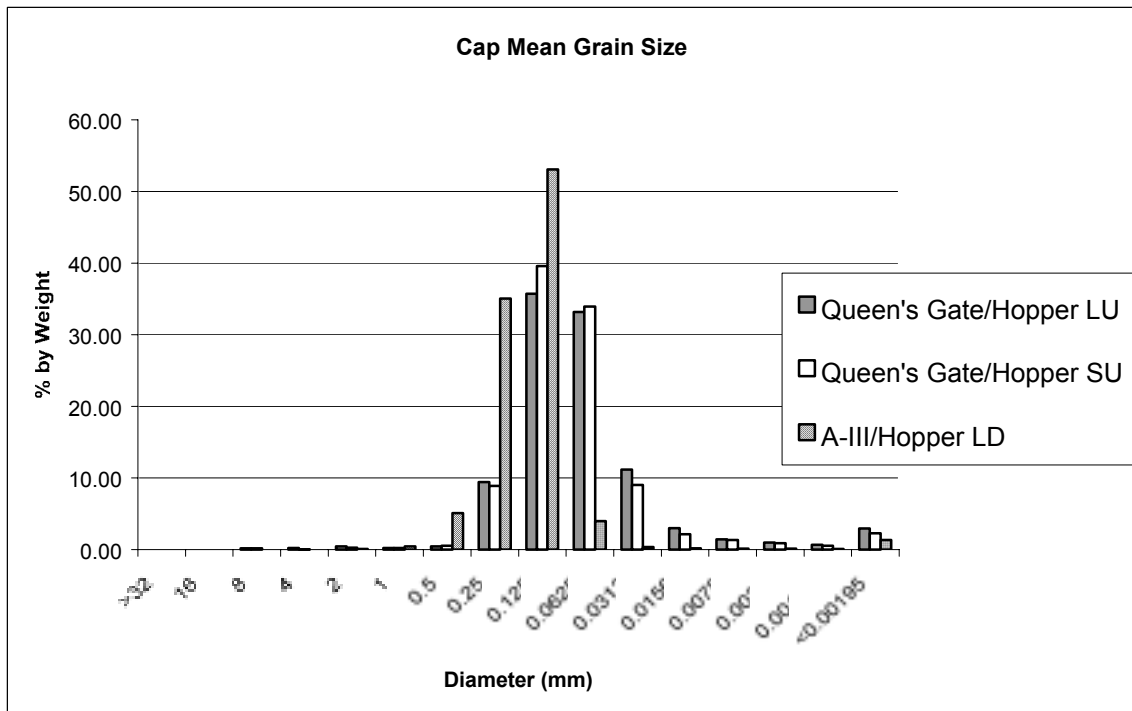

Figure 3-39. Mean cap material distribution (mm size classes) from dredge hopper samples

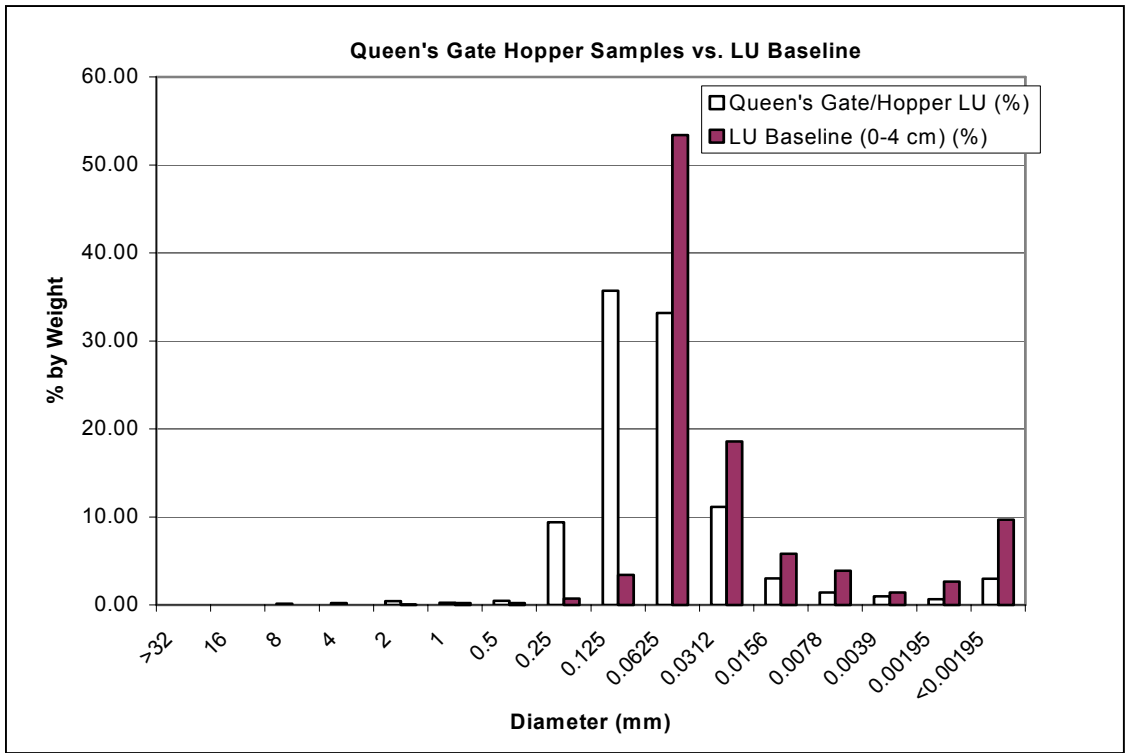

Figure 3-40. Cap material (Queen's Gate) grain size distribution in comparison to LU 0-4-cm baseline (EA) core sections

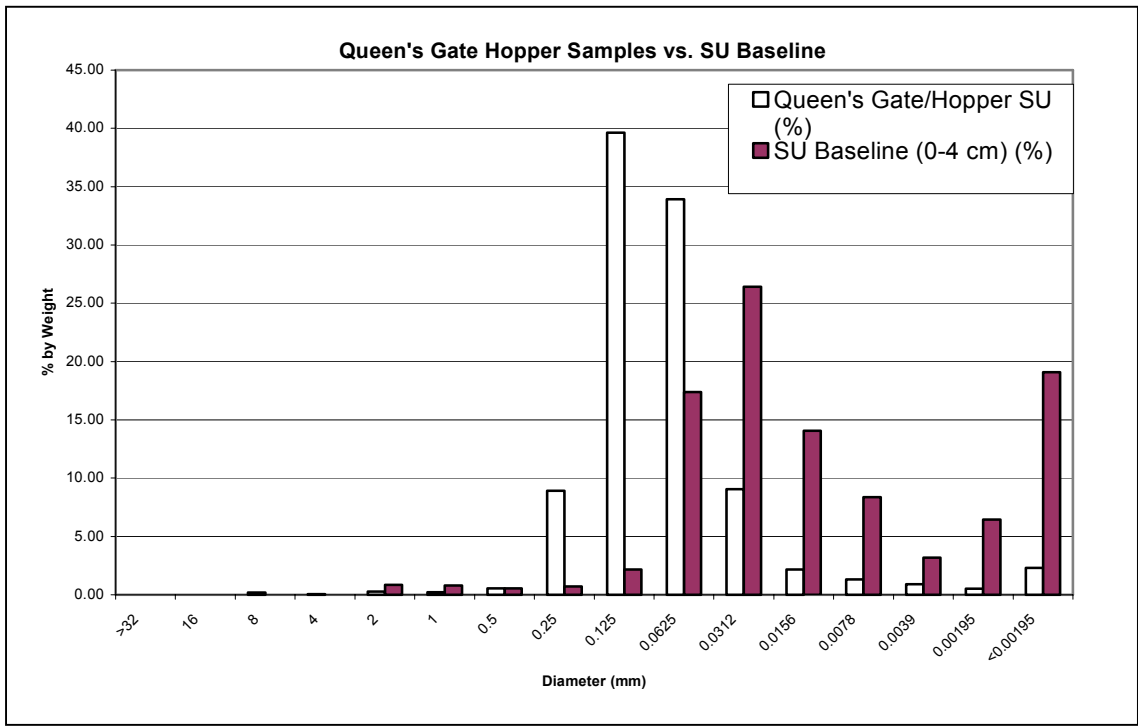

Figure 3-41. Cap material (Queen's Gate) grain size distribution in comparison to SU 0-4-cm baseline (EA) core sections

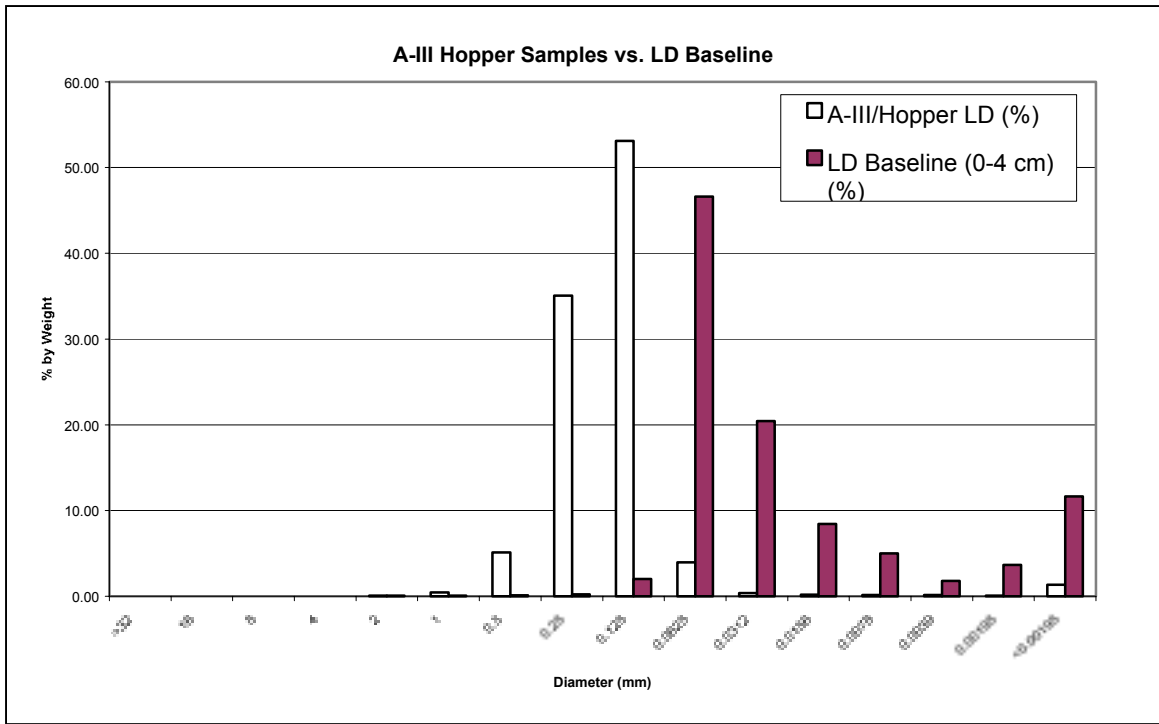

Figure 3-42. Cap material (A-III) grain size distribution in comparison to LD 0-4-cm baseline (EA) core sections

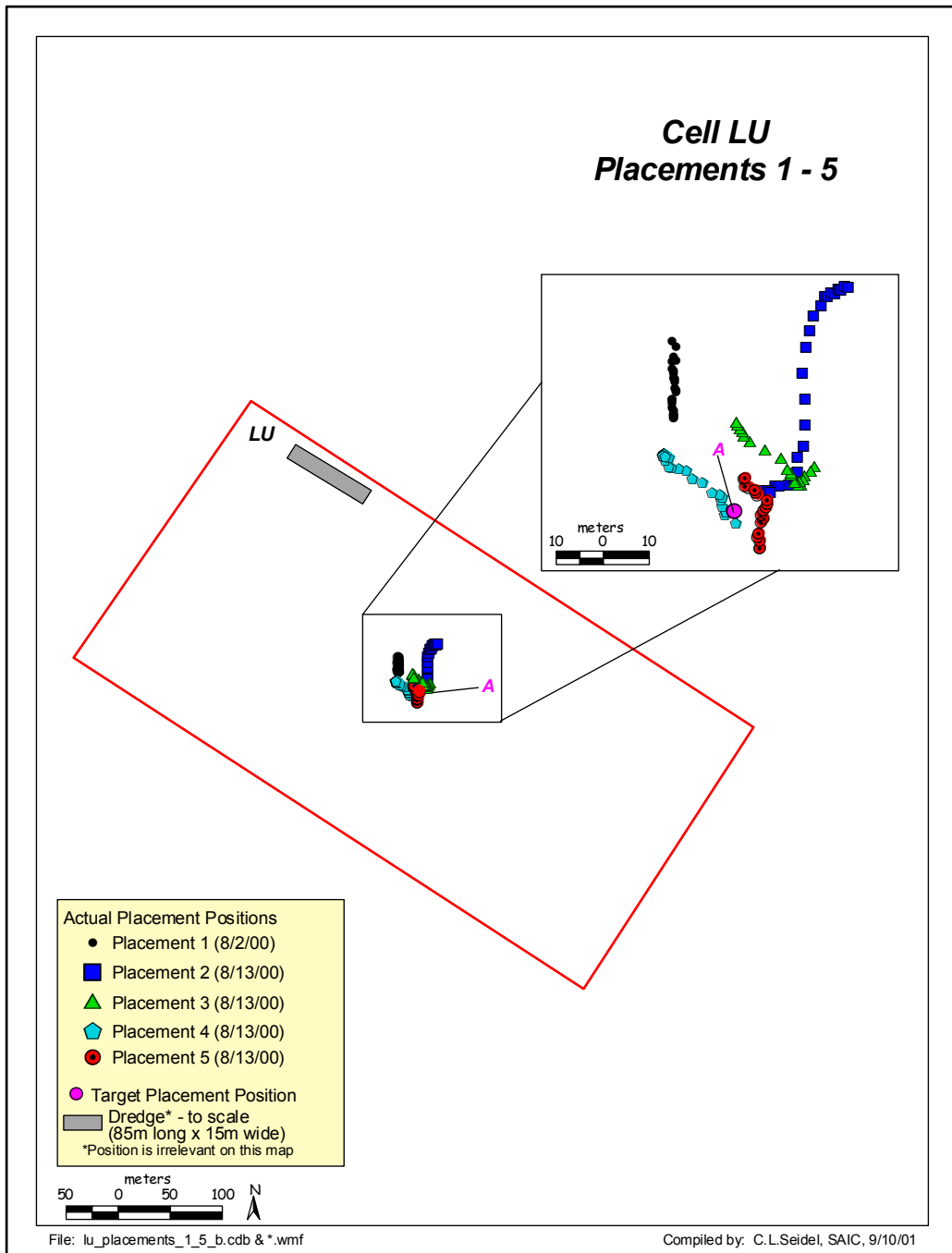

Figure 3-43. Positions recorded by the ADISS electronic tracking system of first five loads of cap material at Cell LU. Gray rectangle provides scale for size of dredge

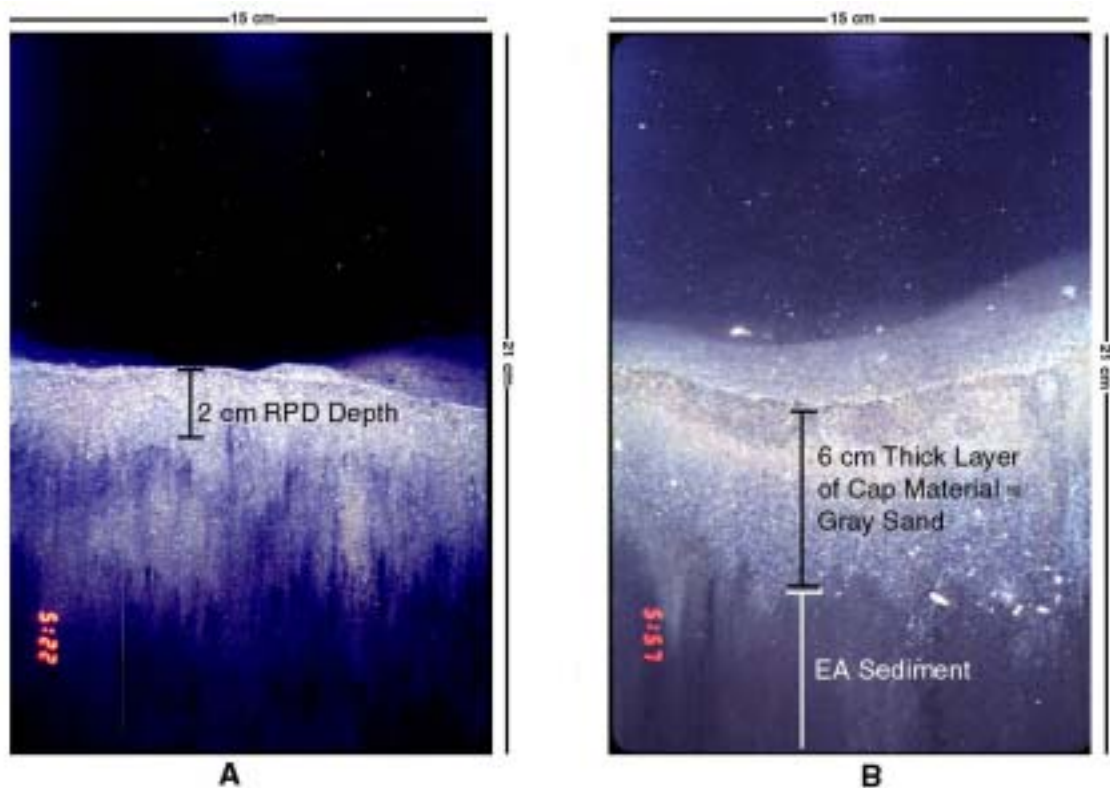

Figure 3-44. Two sediment-profile images from sta I08 to illustrate appearance of cap material layer on seafloor following single hopper placement event in Cell LU. Image A from background survey shows existing fine-grained sediment prior to cap material placement, with RPD depth of 2.0 cm. Image B from Post-1 survey shows distinct depositional layer of gray-colored, fine sand overlying existing fine-grained sediment at depth. Point of contact between cap material layer and underlying existing sediment is distinct. Light-colored, fine-grained sediment comprising the RPD in left image has been replaced, in effect, by depositional layer of capping sand at right

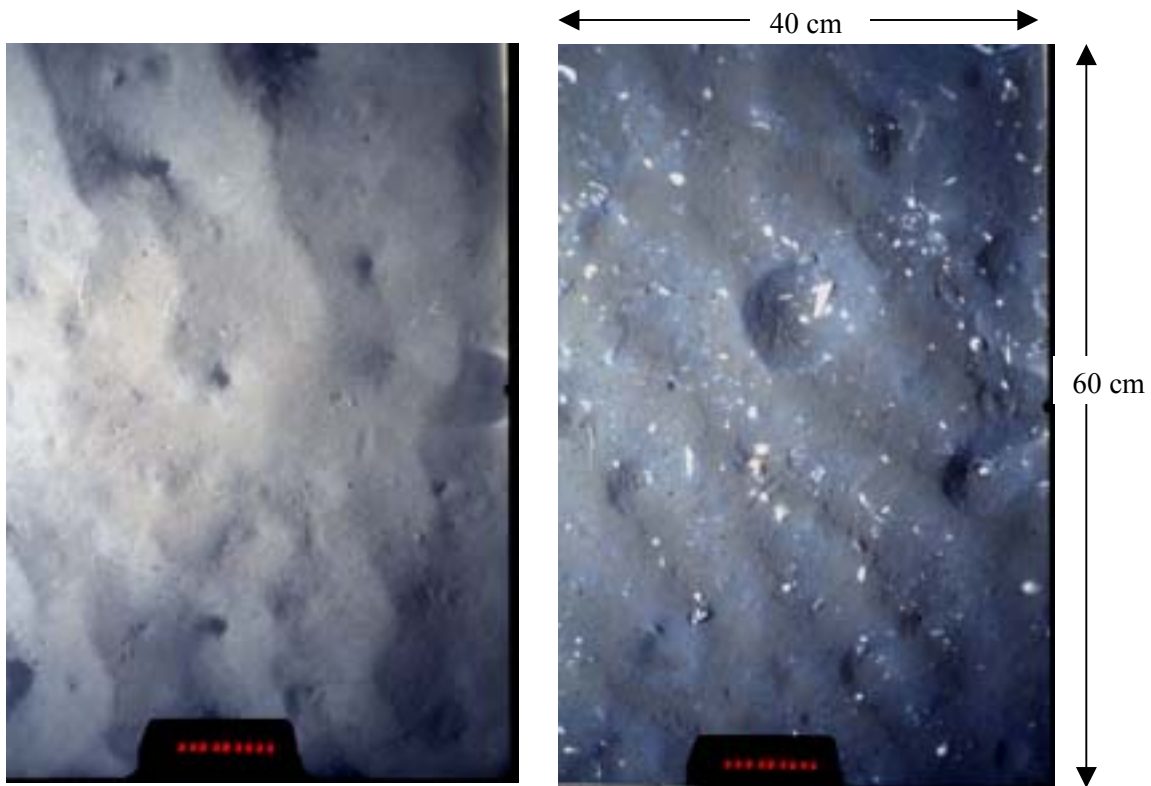

Figure 3-45. These images taken at Cell LU stations during post 1 survey display differences in color between the lighter colored EA sediments away from cap on left and darker cap material which also contains shell hash on right near where cap was released

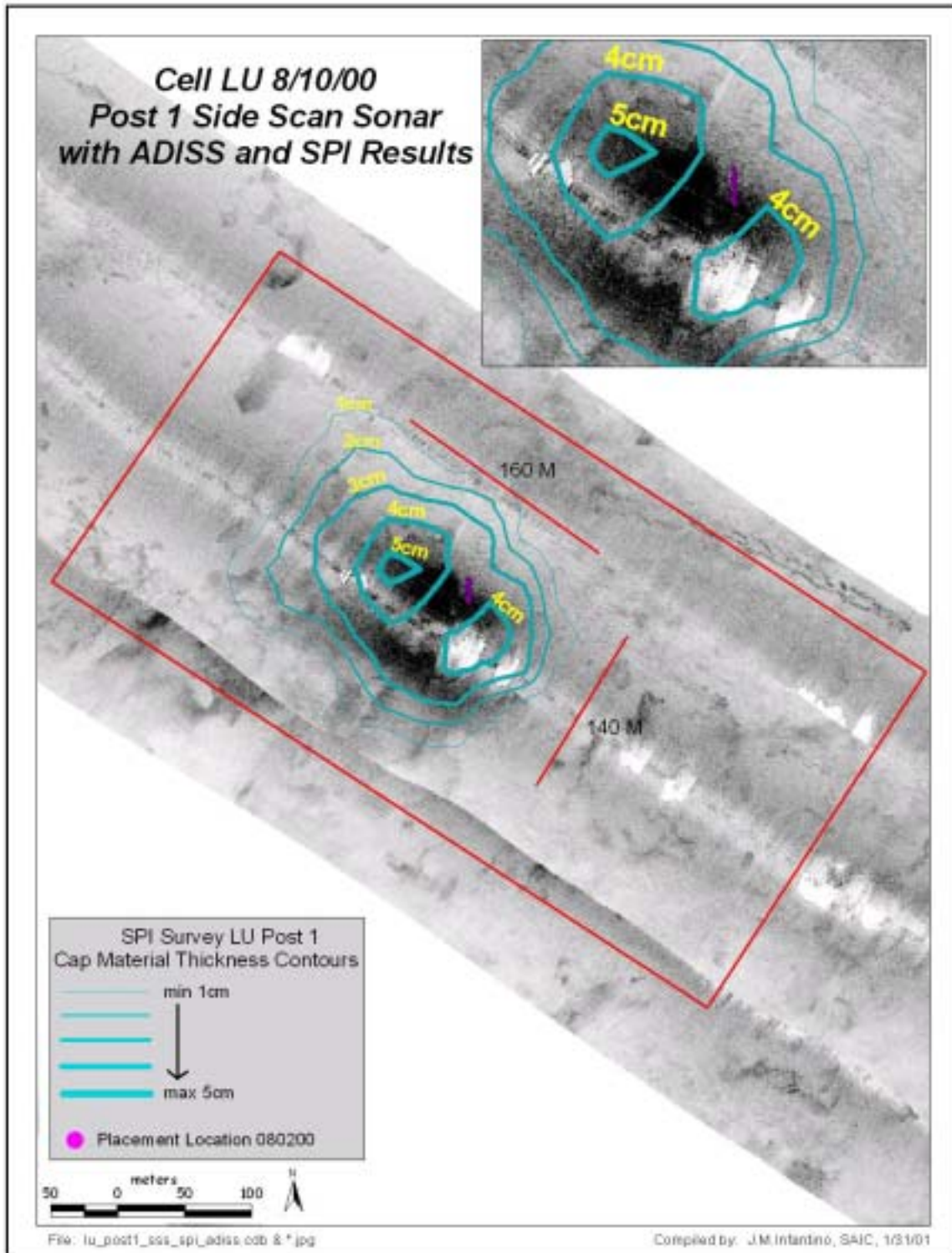

Figure 3-46. Side-scan sonar imagery after first load of cap material placed in Cell LU

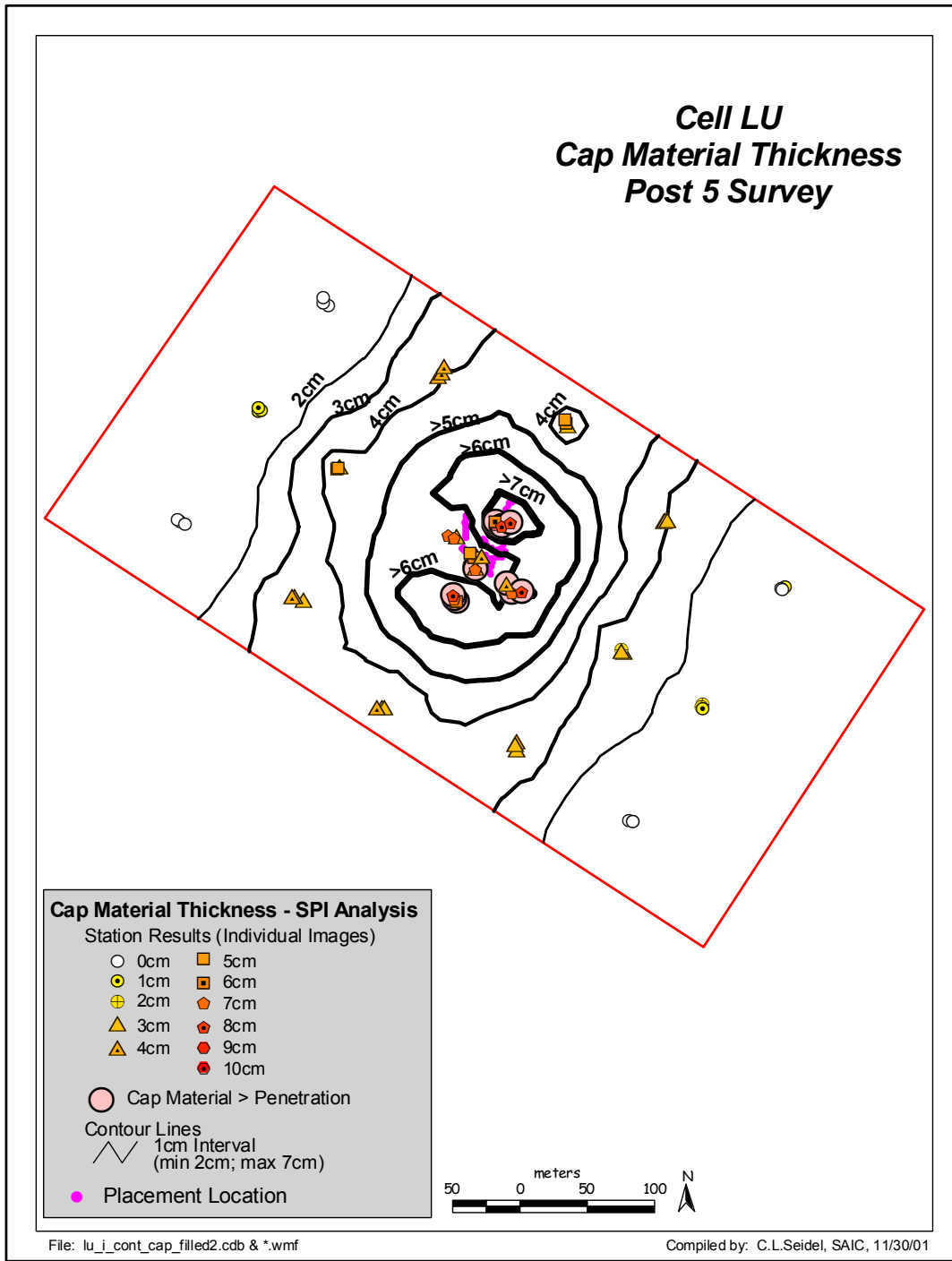

Figure 3-47. Distribution of cap material as determined by SPI camera after five cap placement events in the center of Cell LU

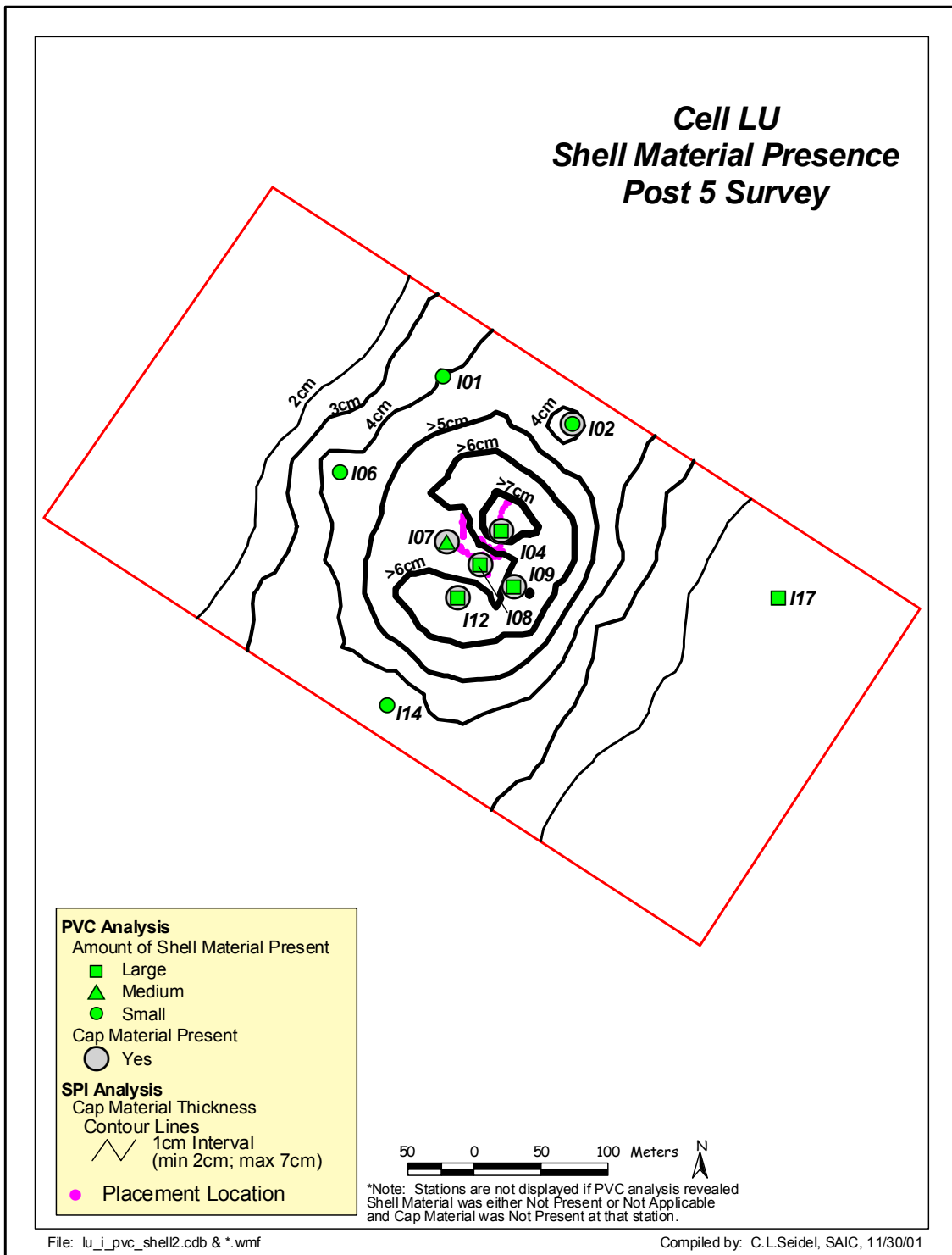

Figure 3-48. Distribution of cap material as determined by plan view camera after five cap placement events in center of Cell LU

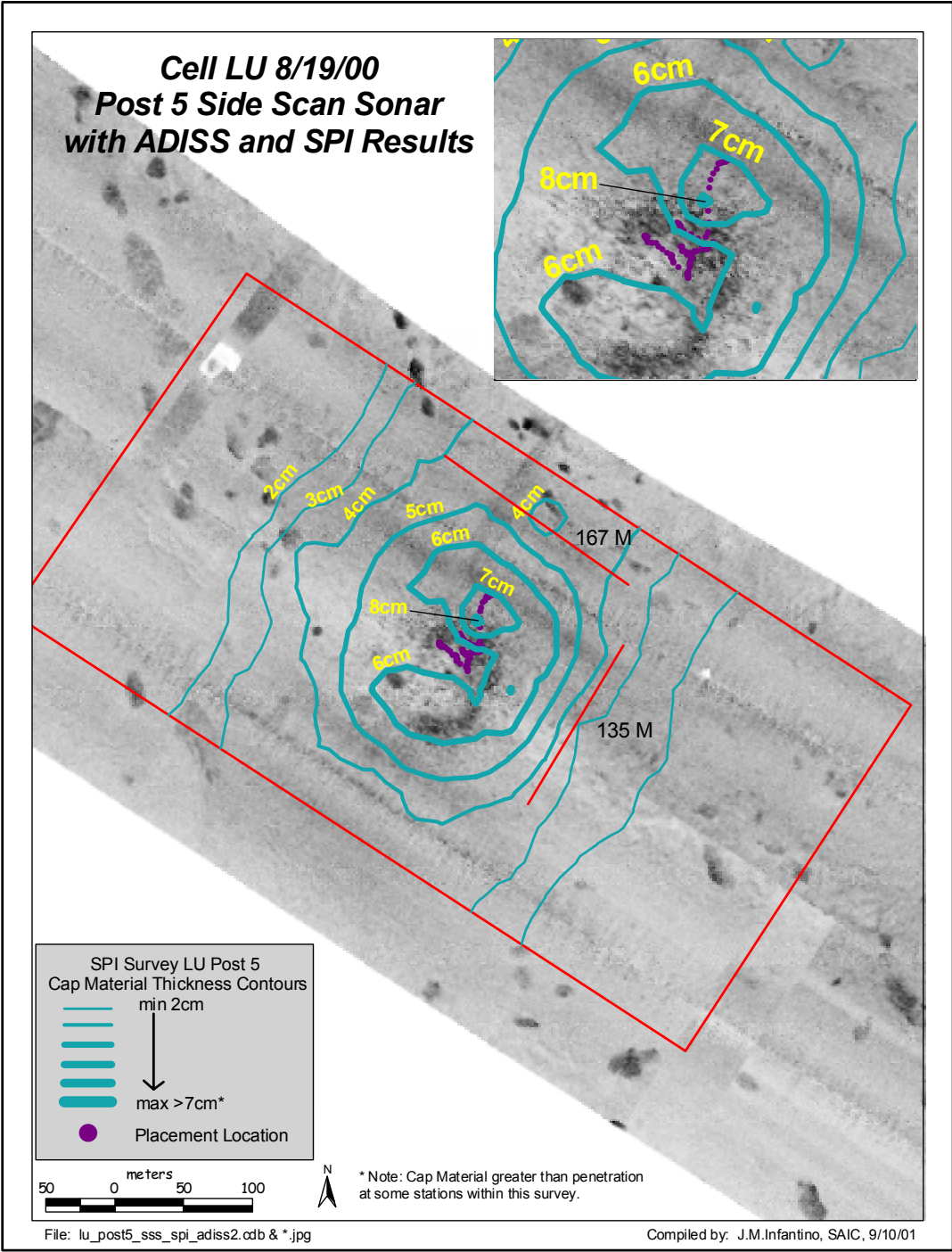

Figure 3-49. Results of the side-scan sonar survey after five cap placement events with SPI contours overlaid

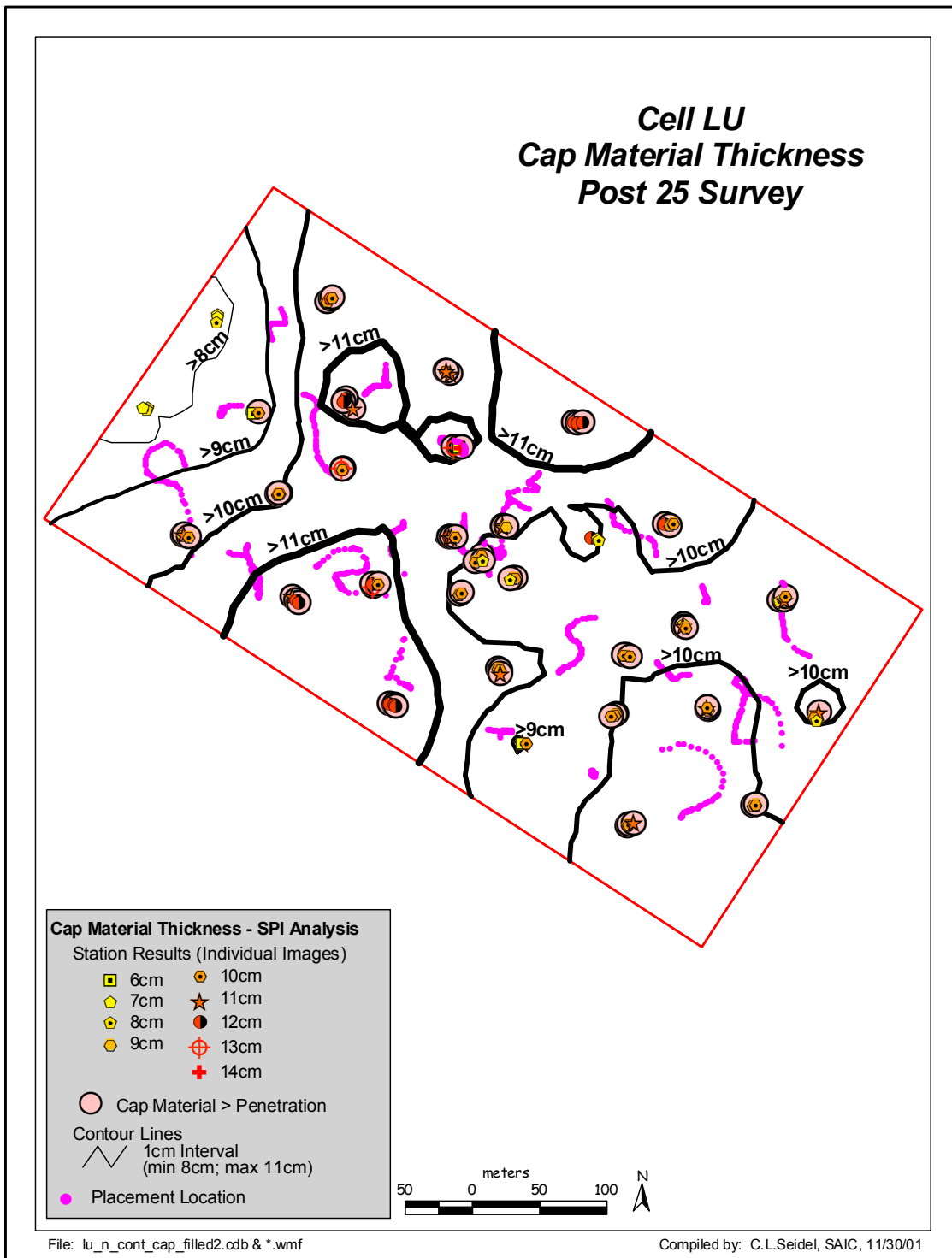

Figure 3-50. Distribution of cap determined by SPI camera after 25 placement events in Cell LU

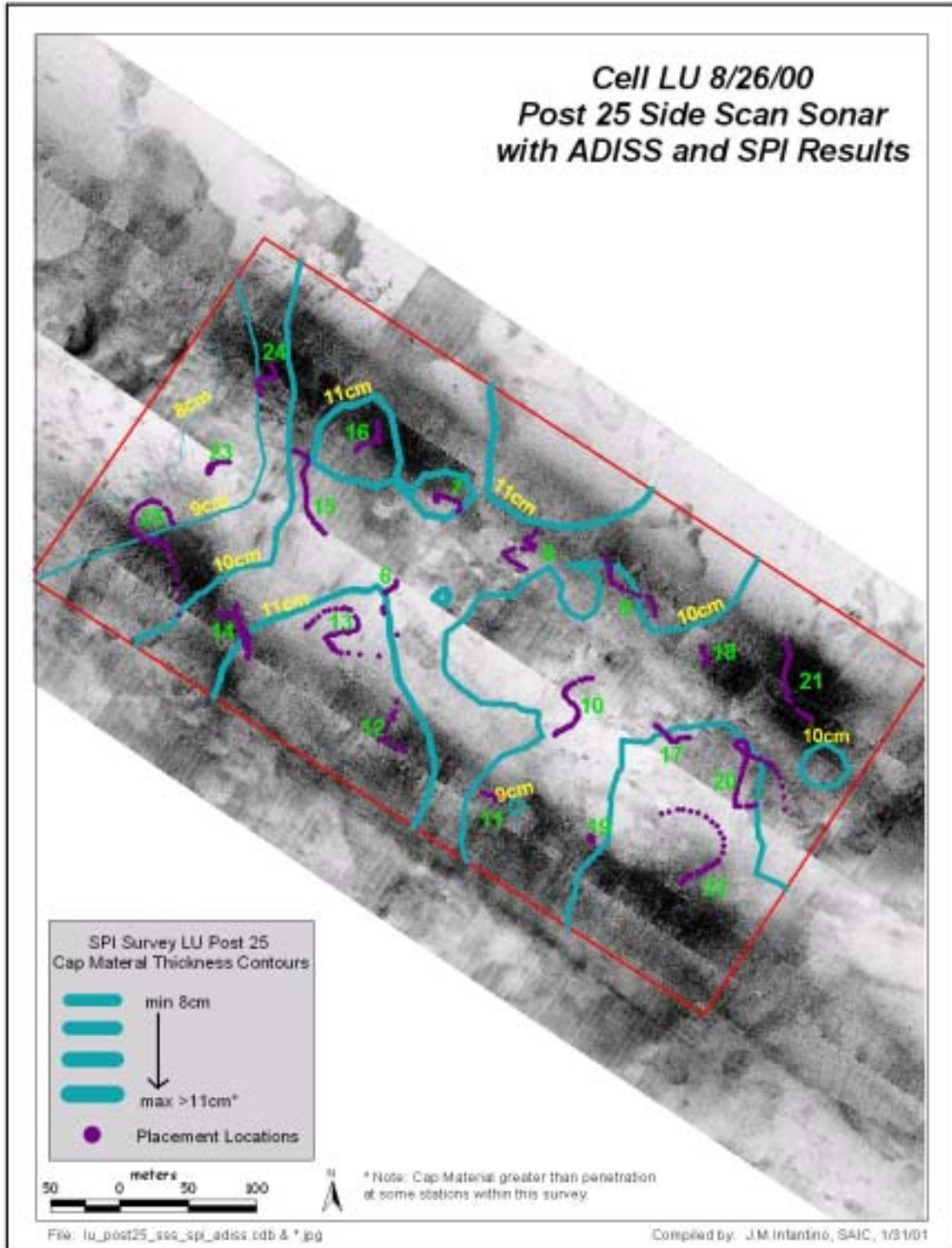

Figure 3-51. Side-scan sonar results after 25 placement events in Cell LU with SPI contours overlaid

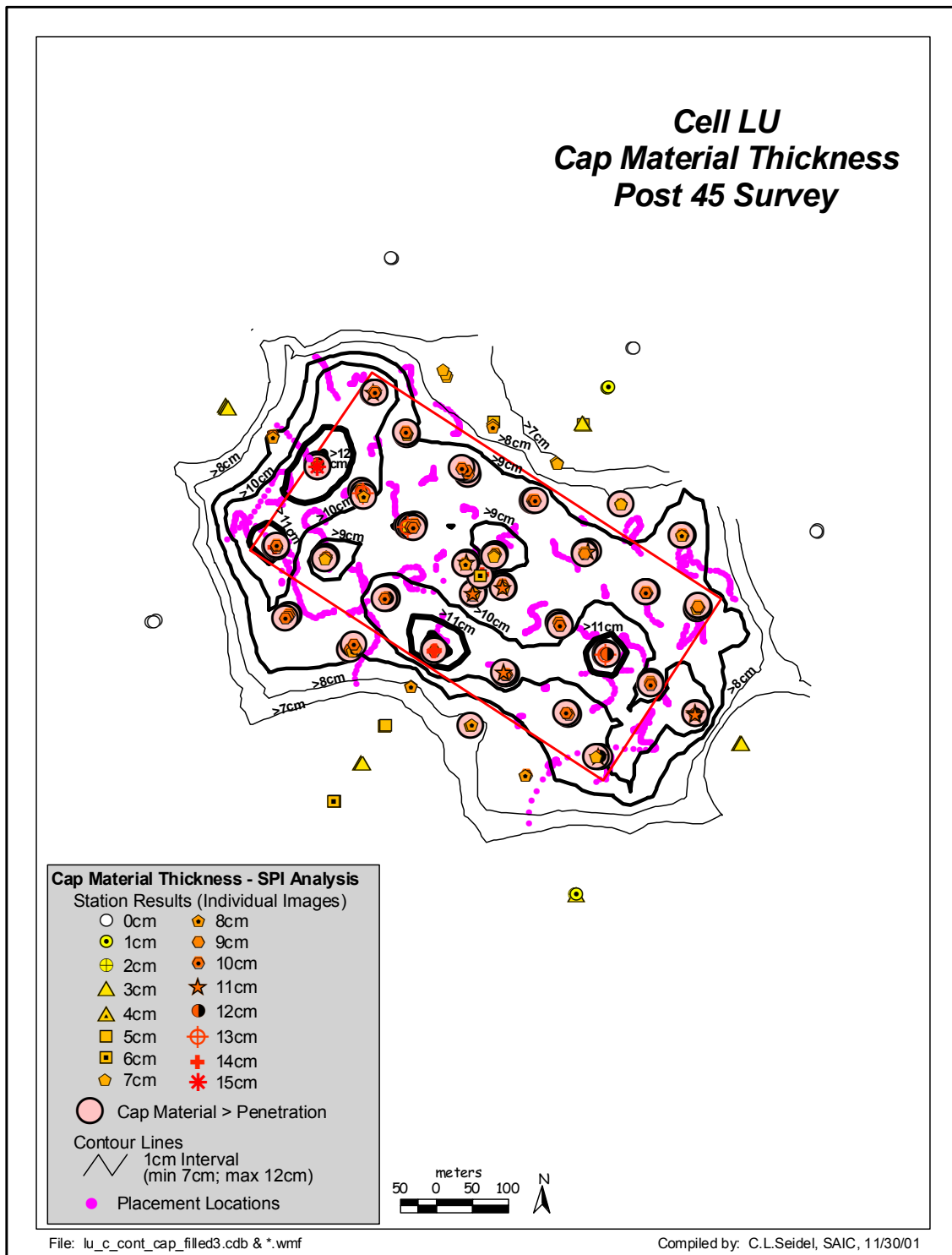

Figure 3-52. Distribution of cap determined by SPI camera after 45 placement events in Cell LU

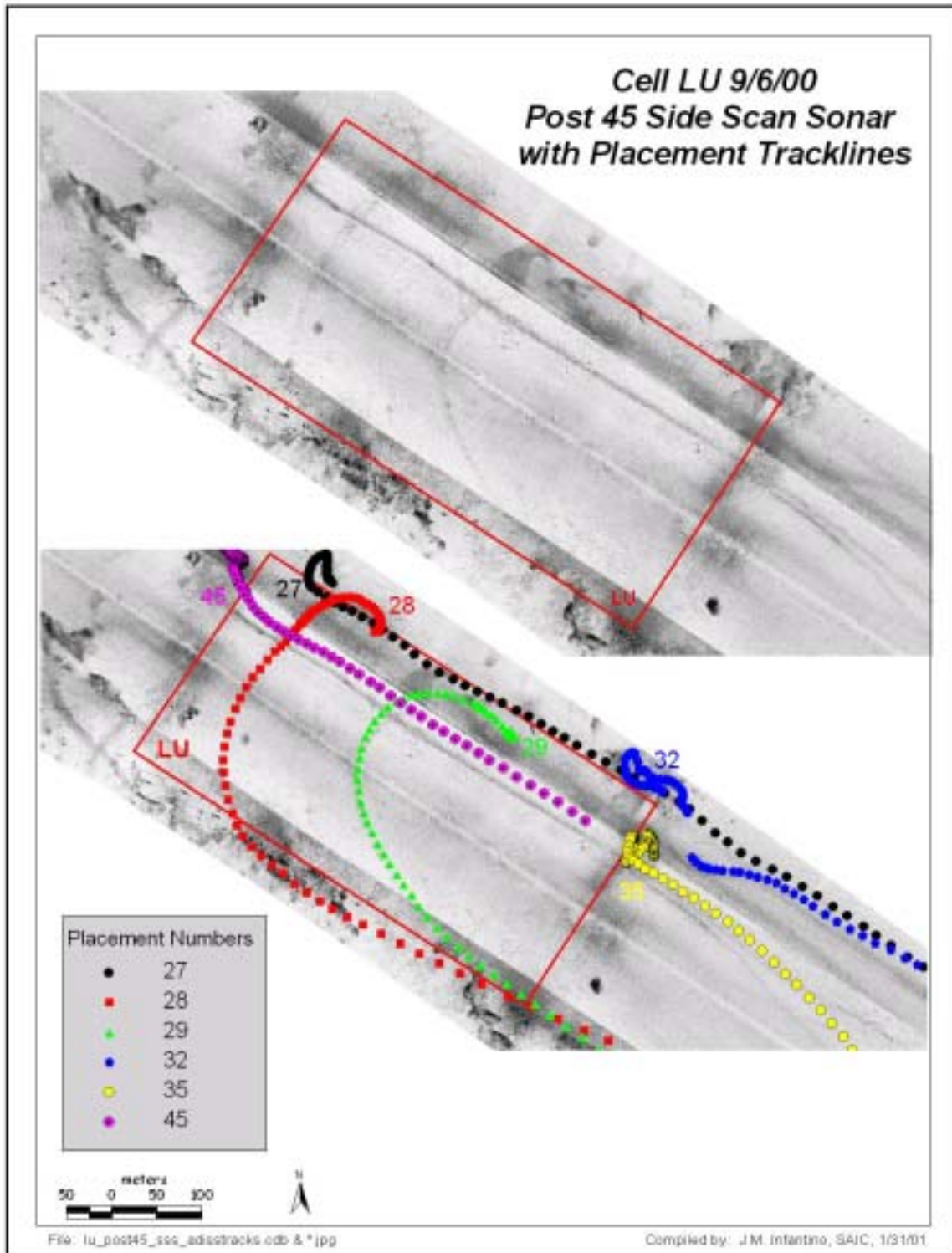

Figure 3-53. Side-scan sonar mosaic with dredge departure trails – LU Post 45

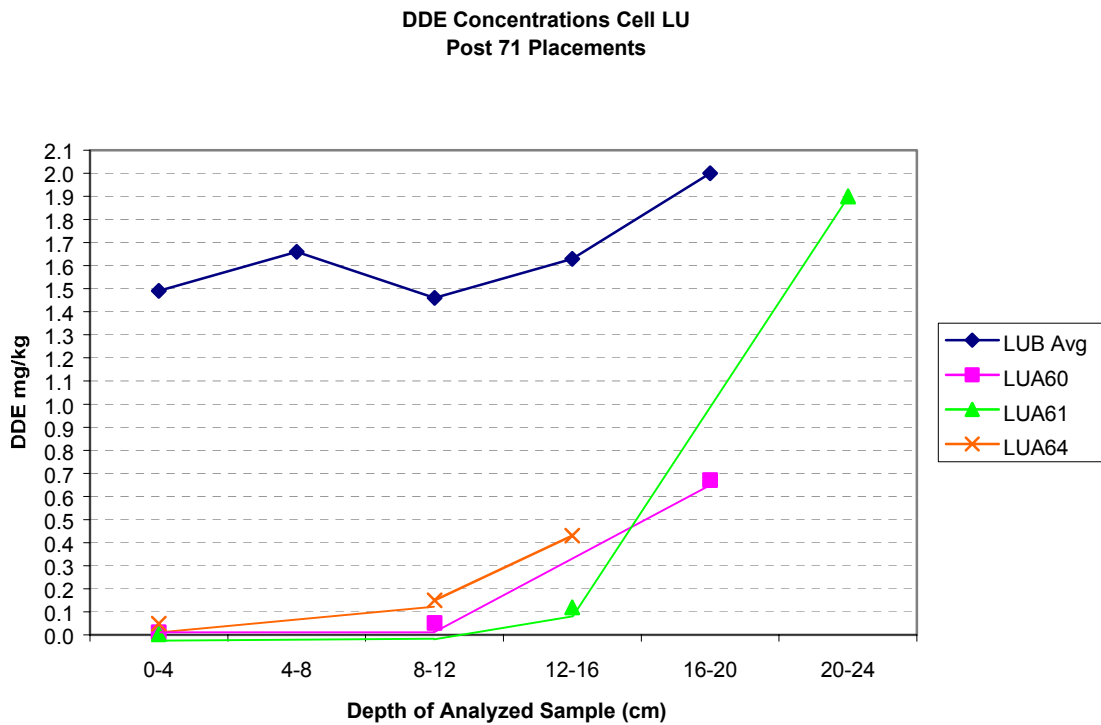
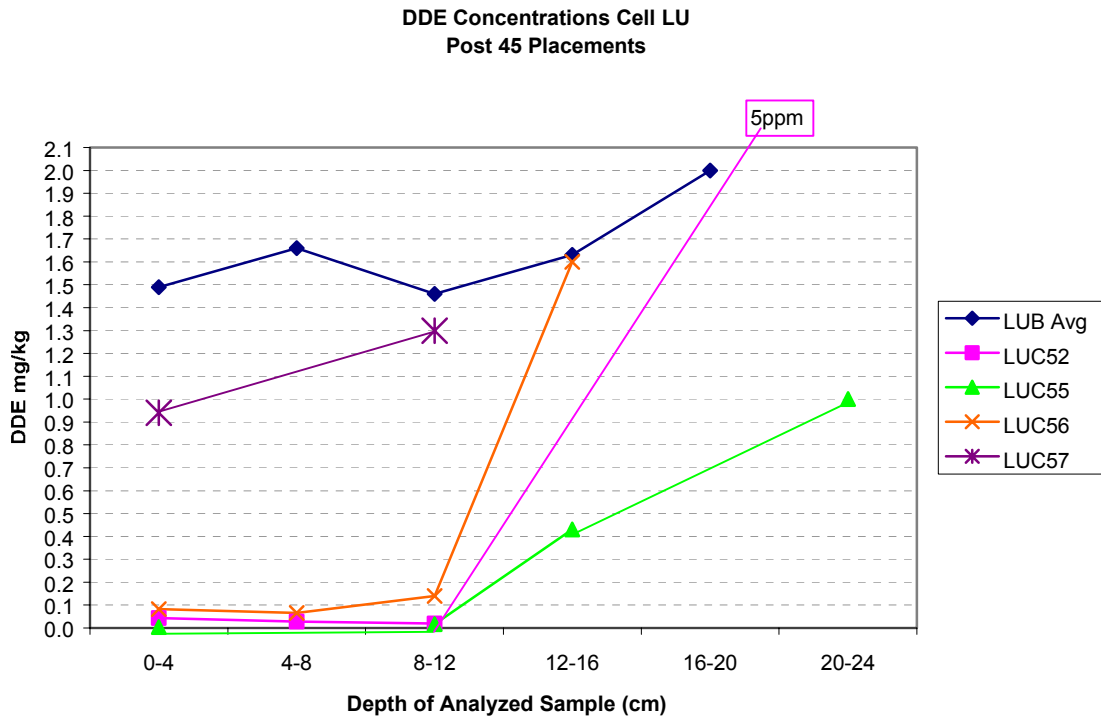

Figure 3-54. Down-core DDE concentrations in Post-45 (top) and Post-71 (bottom) LU cores in comparison to baseline EA sediment (LUBAVG)

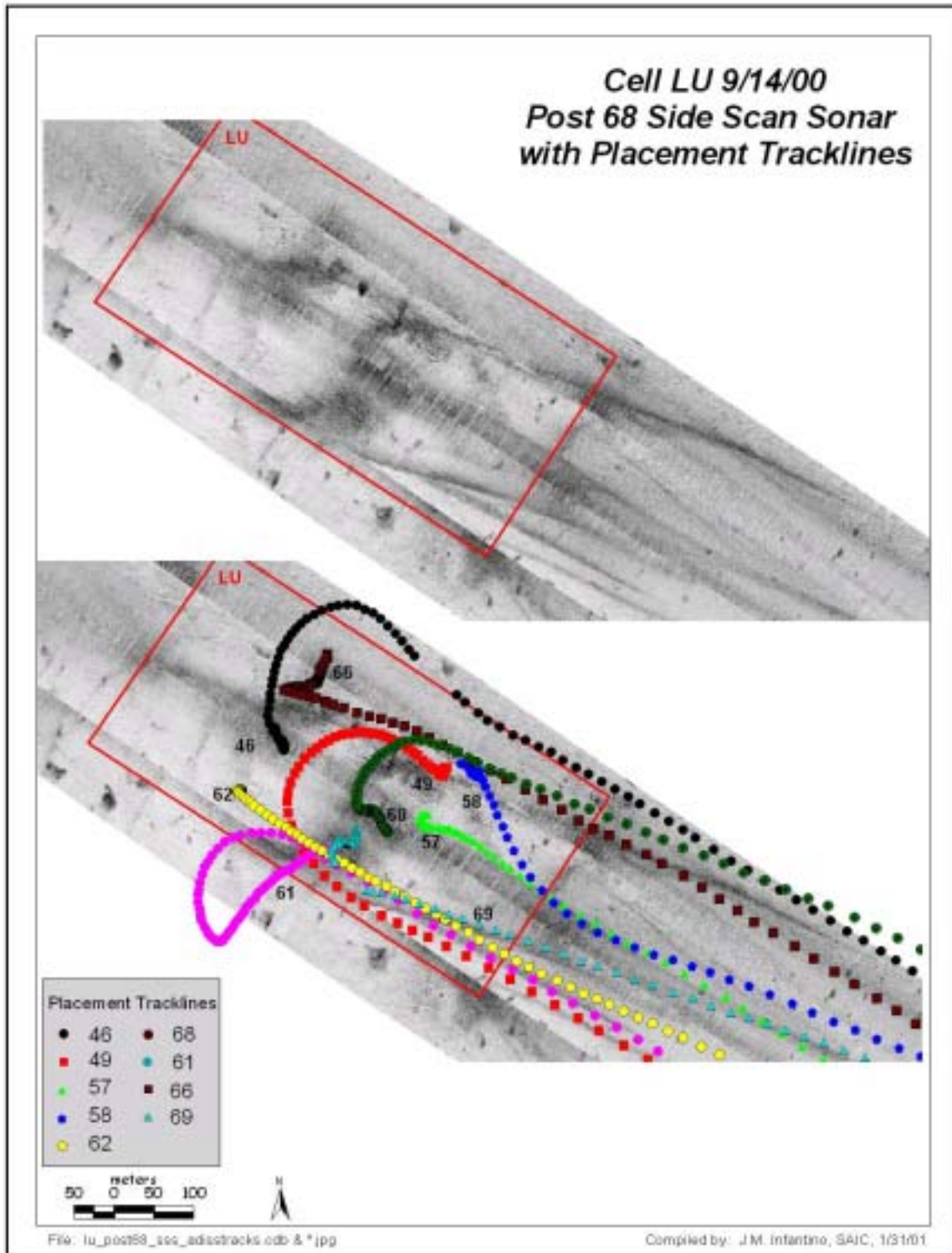

Figure 3-55. Side-scan sonar mosaic with dredge departure trails – LU Post 68

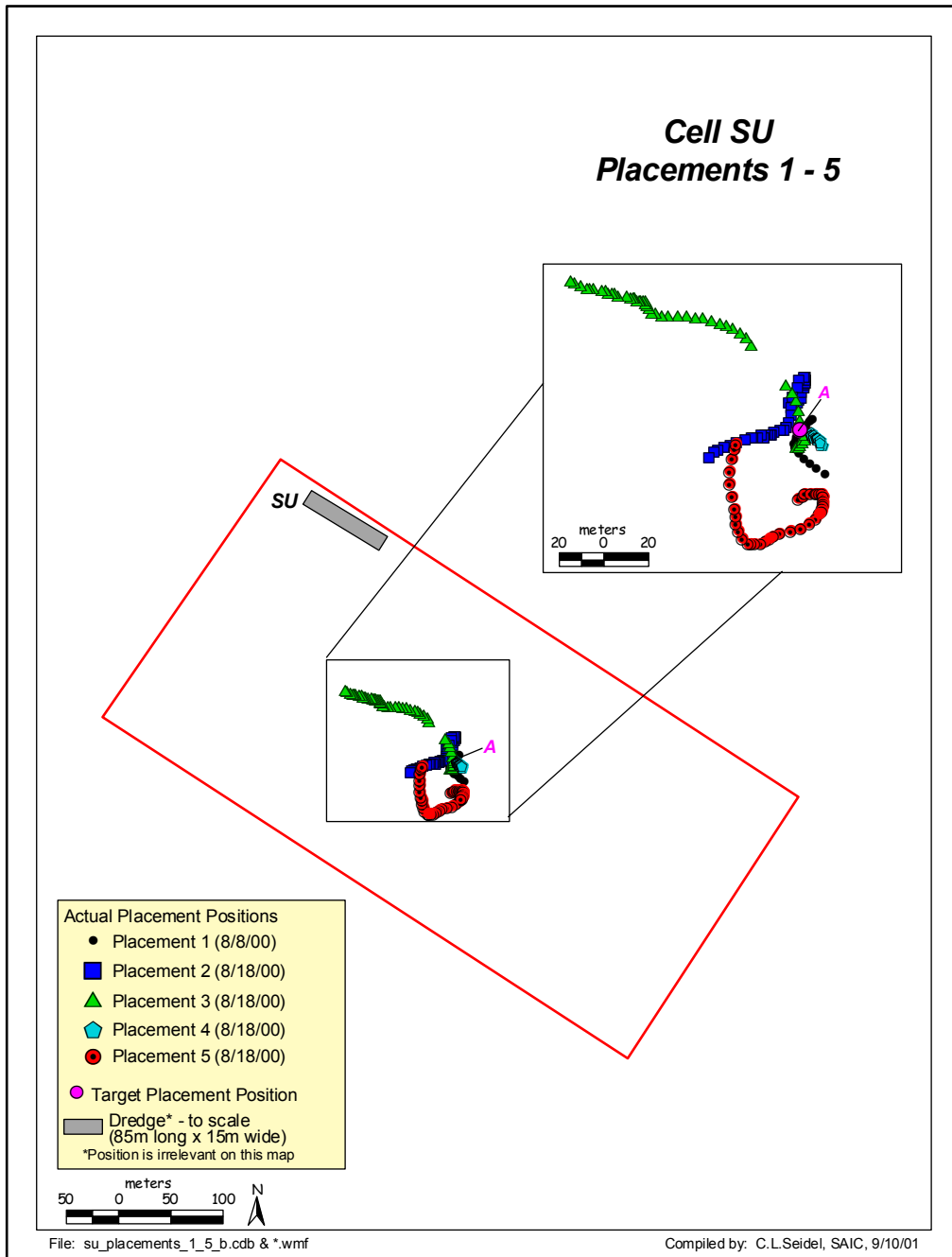

Figure 3-56. Map illustrating Cell SU on Palos Verdes Shelf and positions of hopper dredge *Sugar Island* during placement of cap material during Events 1-5 in August 2000. Dredge position data were acquired by ADISS. Gray box shows dimension of dredge

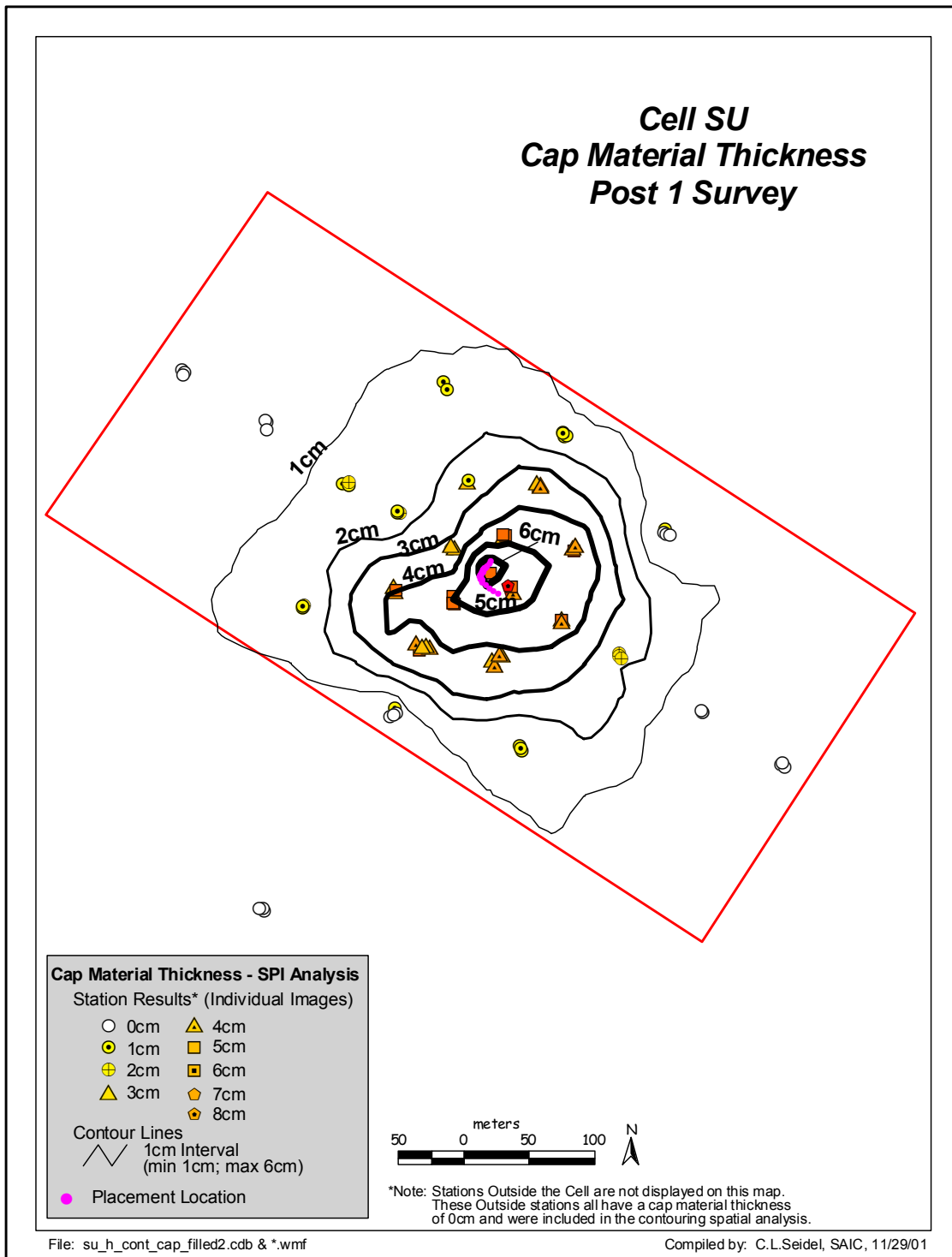

Figure 3-57. Placement location and thickness of cap material on seafloor for the Post 1 SPC survey in Cell SU. Contour lines are based on average measured thickness of cap material layer at each station (mean of n = 3 replicate sediment profile images), while each plotted symbol depicts cap material thickness measurement for individual replicate image

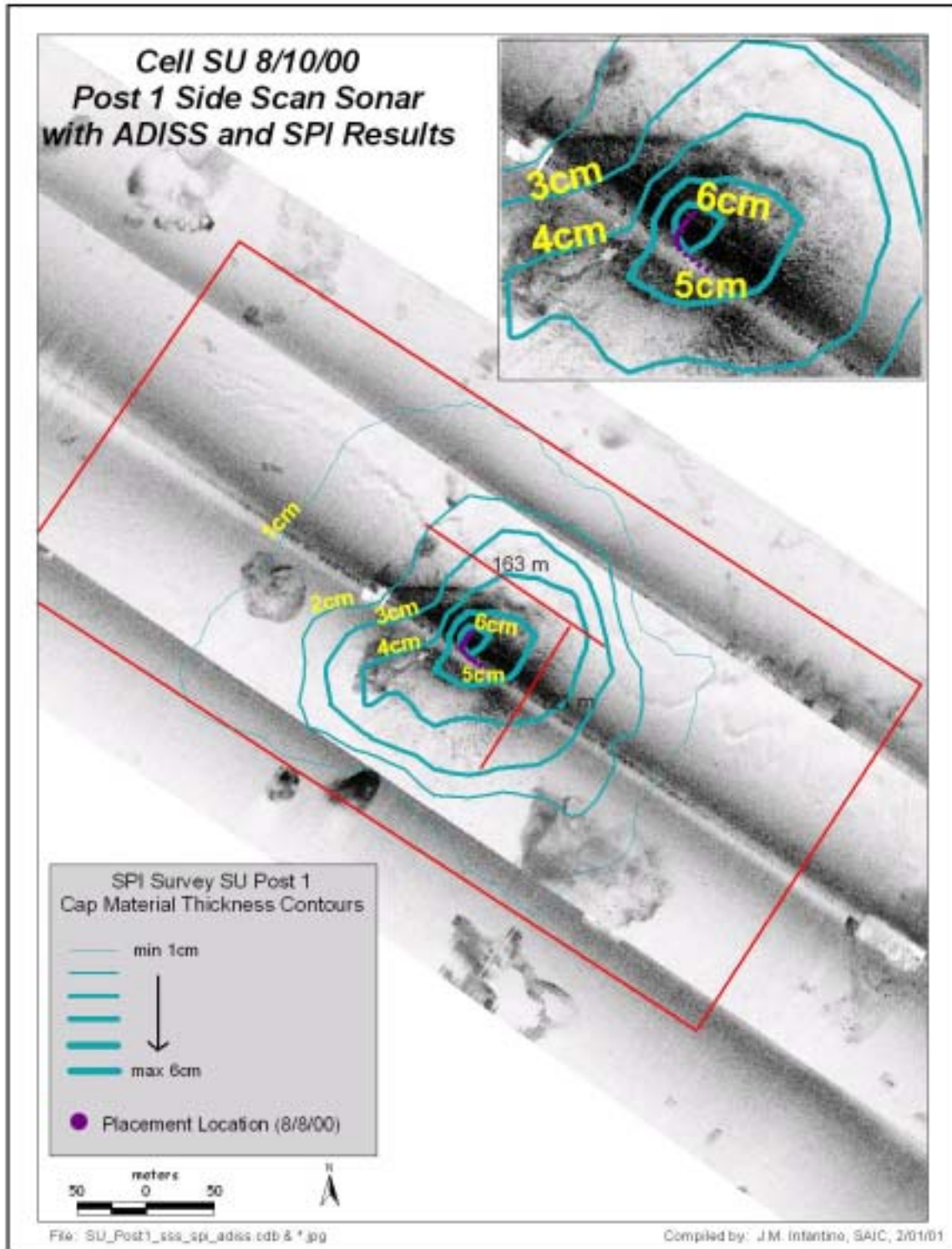

Figure 3-58. Side-scan sonar mosaic with SPI cap contours – SU Post 1

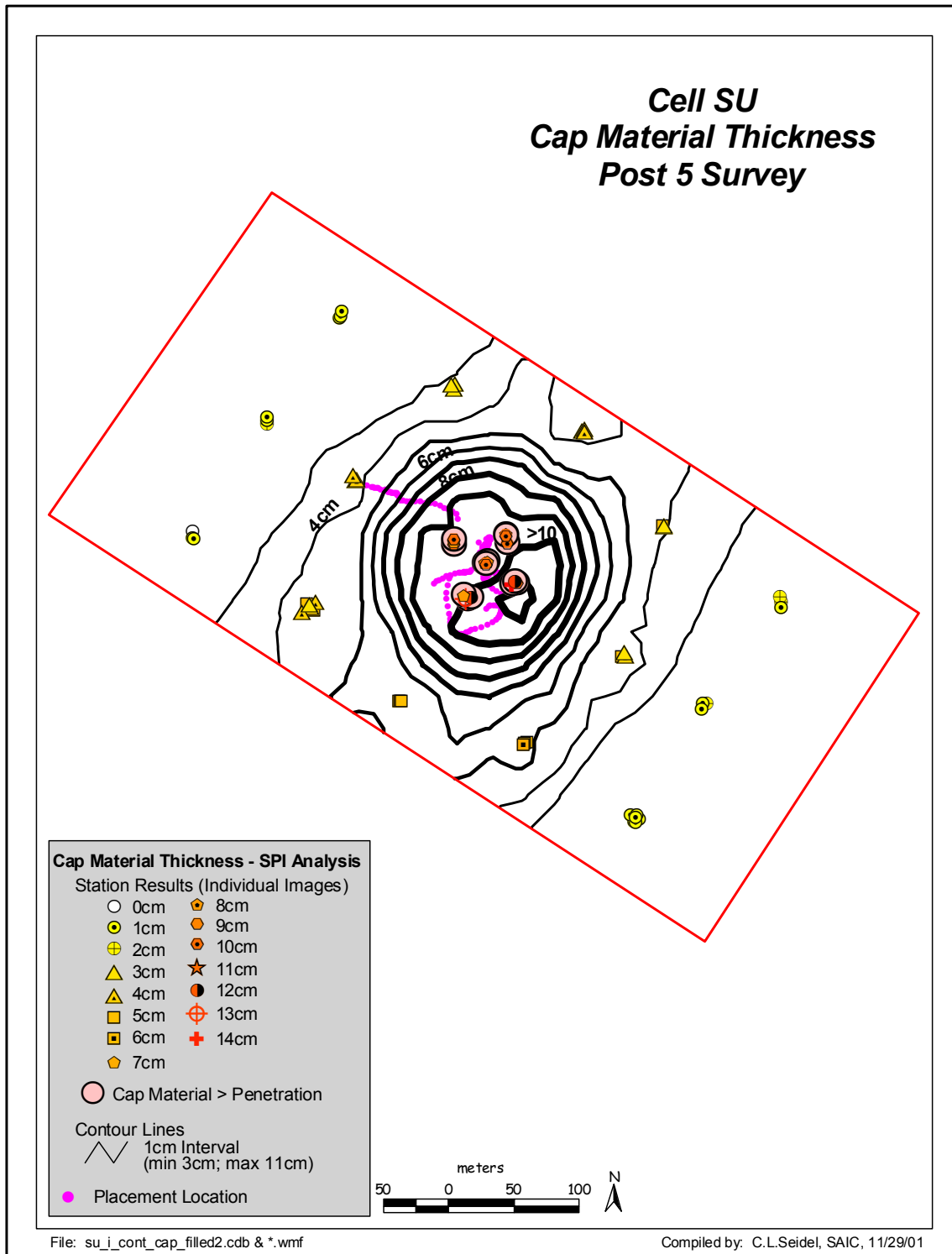

Figure 3-59. Placement locations and thickness of cap material on seafloor in Cell SU for Post 5 SPC survey. Contour lines are based on average measured thickness of cap material layer at each station (mean of n = 3 replicate sediment profile images), while each plotted symbol depicts cap material thickness measurement for individual replicate image. Note that cap material layer thickness exceeded penetration depth of sediment profile camera in a number of images near center of the cell (cap material > penetration)

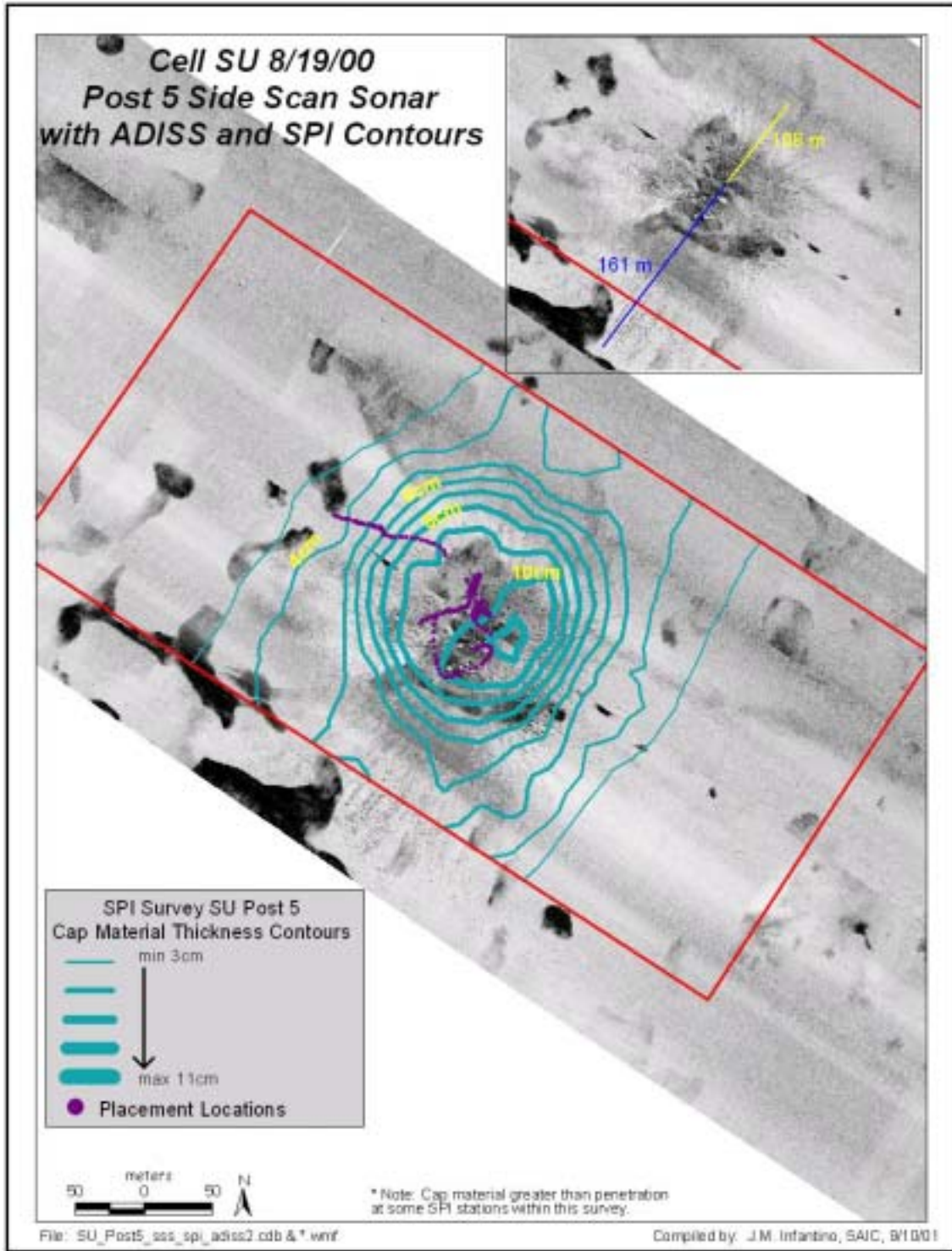

Figure 3-60. Side-scan sonar mosaic with SPI cap contours – SU Post 5. Inset shows central area of cell

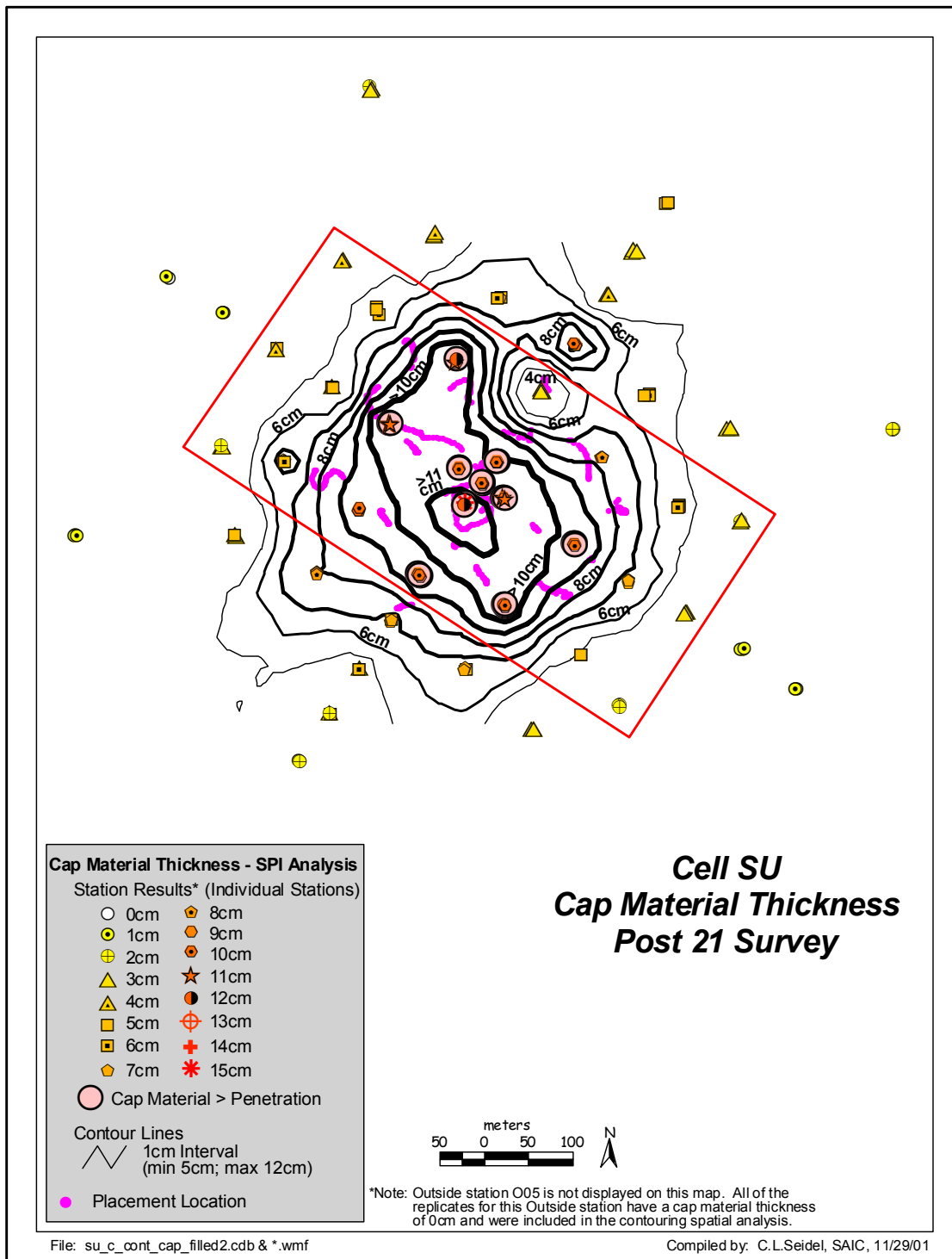

Figure 3-61. Placement locations and thickness of cap material on the seafloor in Cell SU for Post 21 SPC survey. Contour lines are based on average measured thickness of cap material layer at each station (mean of n = 3 replicate sediment profile images), while each plotted symbol depicts cap material thickness measurement for individual replicate image. Note that average cap material layer thickness exceeded penetration depth of sediment profile camera at 10 stations inside cell boundary (cap material > penetration)

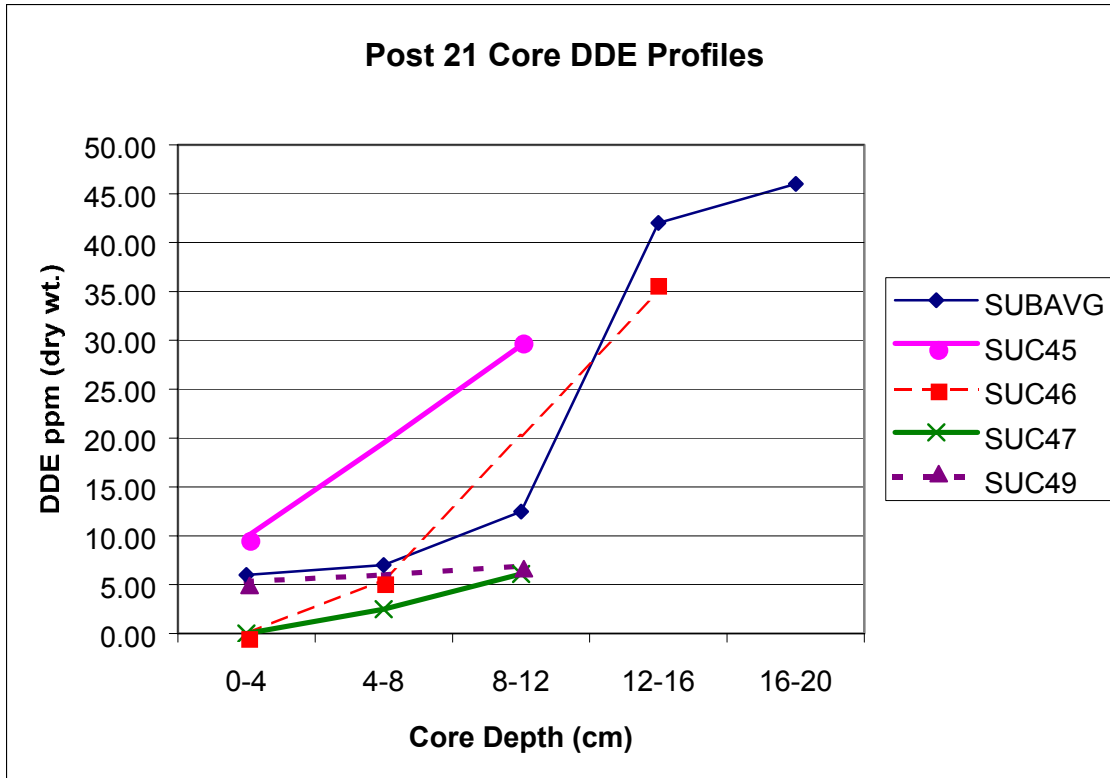

Figure 3-62. Down-core DDE concentrations in Post-21 cores in comparison to baseline (SUBAVG) EA sediment. Cores SUC46 and SUC47 were located on central portion of cap and cores SUC45 and SUC49 were farther out toward cap edge

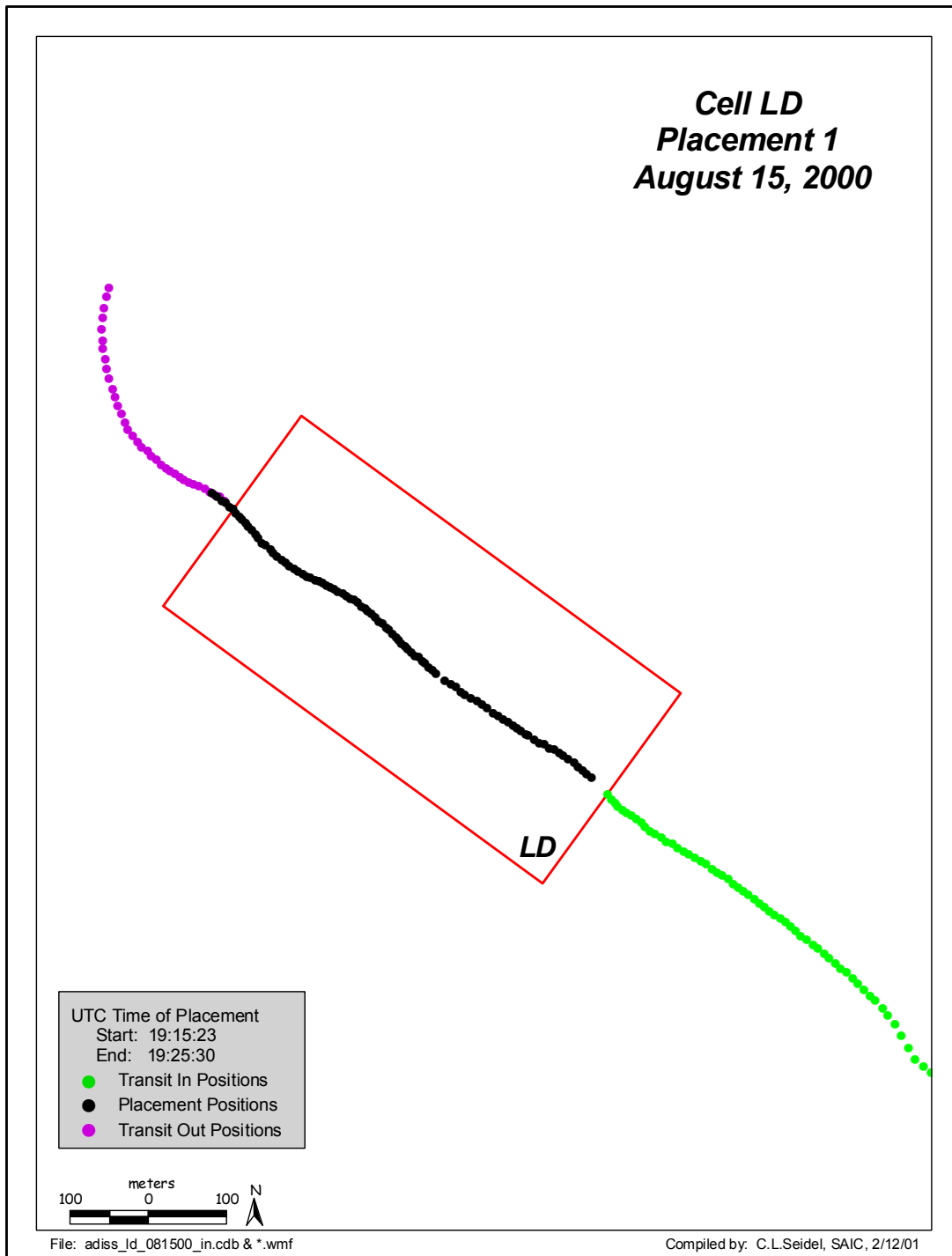

Figure 3-63. Map illustrating Cell LD on the Palos Verdes Shelf and the trackline of the hopper dredge *Sugar Island* as it traveled northwestward along axis of cell during spreading Event 1 on August 15, 2000. Dredge position data were acquired by ADISS

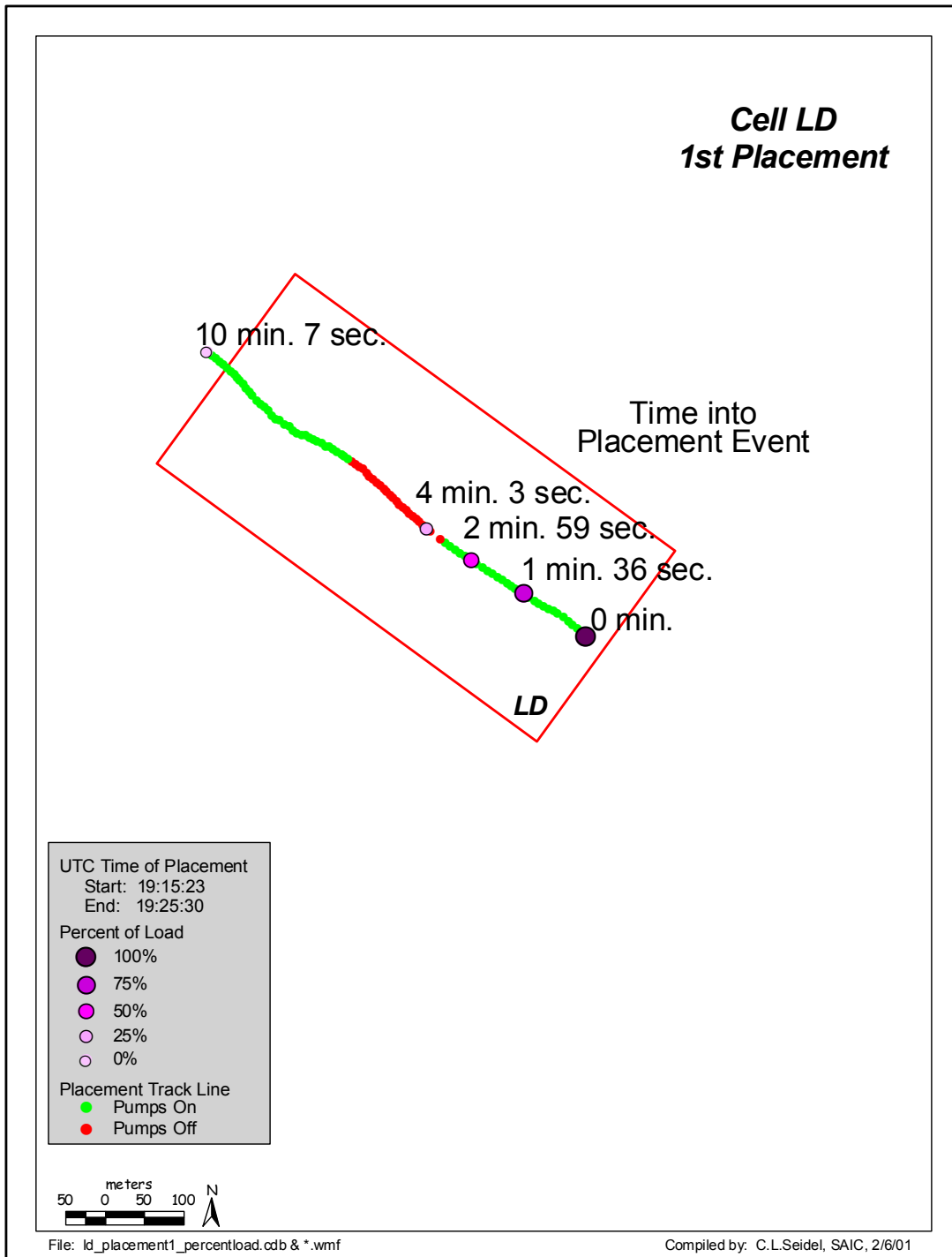

Figure 3-64. Map illustrating Cell LD on the Palos Verdes Shelf and positions of hopper dredge *Sugar Island* as it moved northwestward during spreading of cap material during Event 1 on August 15, 2000. Dredge position data were acquired by ADISS. Also shown are elapsed times that correspond with percent of material (i.e., 100%, 75%, etc.) remaining within the hopper

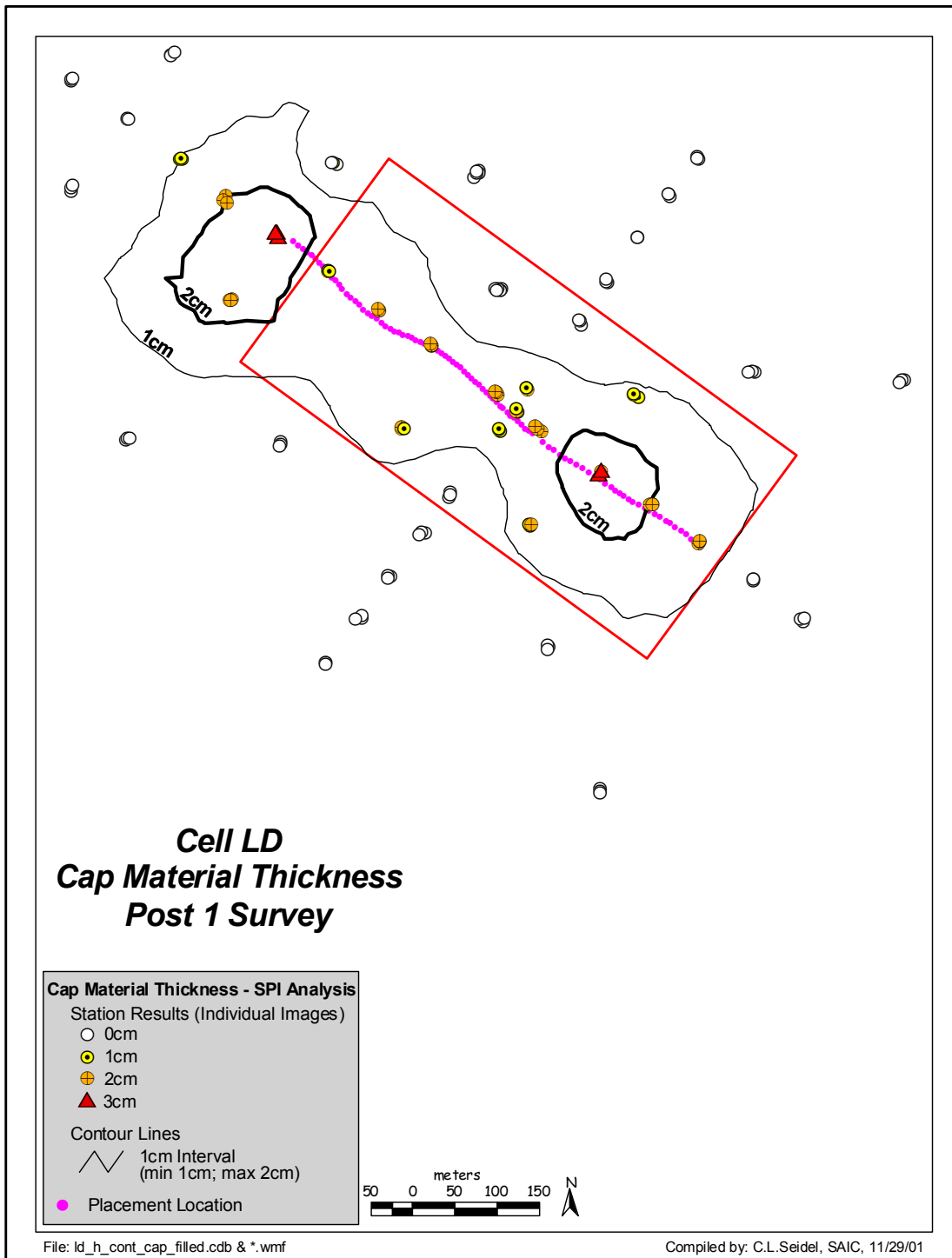

Figure 3-65. Track line of hopper dredge during first spreading placement event in Cell LD, and thickness of resultant cap deposit on seafloor as detected in Post 1 SPC survey. Contour lines are based on average measured thickness of cap material layer at each station (mean of n = 3 replicate sediment profile images), while each plotted symbol depicts cap material thickness measurement for an individual replicate image.

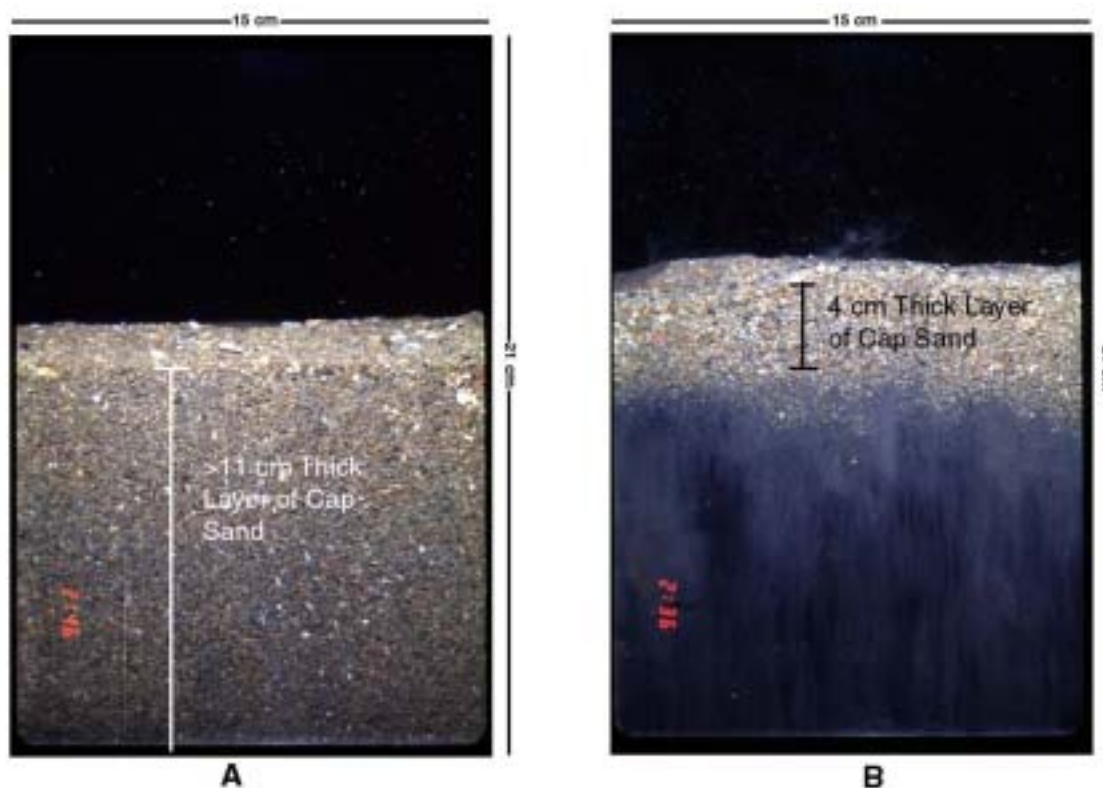

Figure 3-66. Representative sediment profile images from the Post-9 survey in Cell LD. Image A from a station along center line shows cap material from borrow site A-III (homogenous, golden sand) extending from sediment surface to below imaging depth (cap material thickness greater than penetration depth of 11 cm). Image B from station off center line shows discrete layer of golden cap sand measuring 4 cm thick

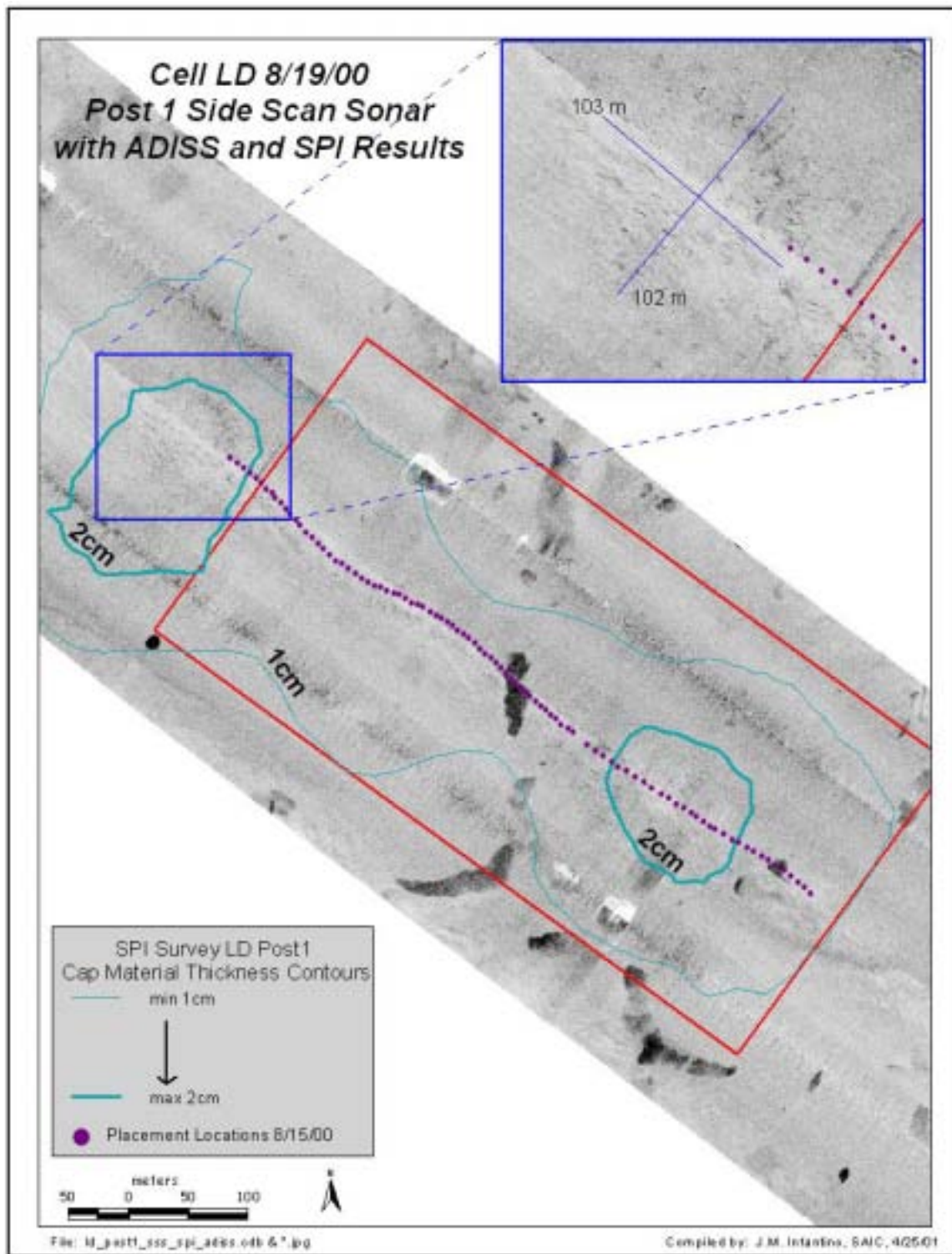

Figure 3-67. Side-scan sonar mosaic with SPI cap contours and ADISS dredge track – LD Post 1

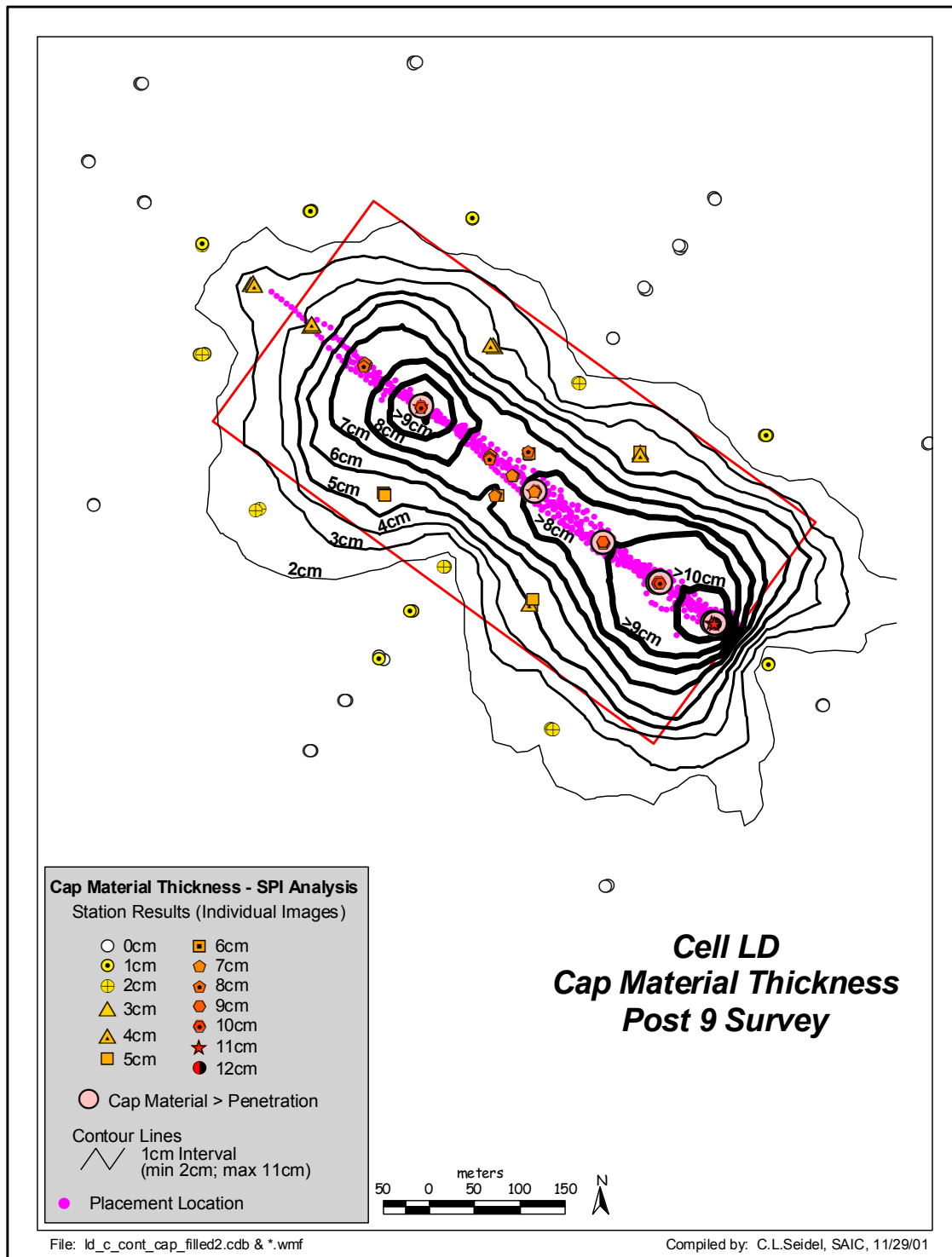

Figure 3-68. Placement locations and thickness of cap material on the seafloor in Cell LD for Post 9 SPC survey. Contour lines are based on average measured thickness of cap layer at each station (mean of n = 3 replicate sediment profile images), while each plotted symbol depicts cap material thickness measurement for individual replicate image. Note that cap layer thickness exceeded penetration depth of sediment profile camera in a number of images along hopper dredge track line (cap material > penetration)

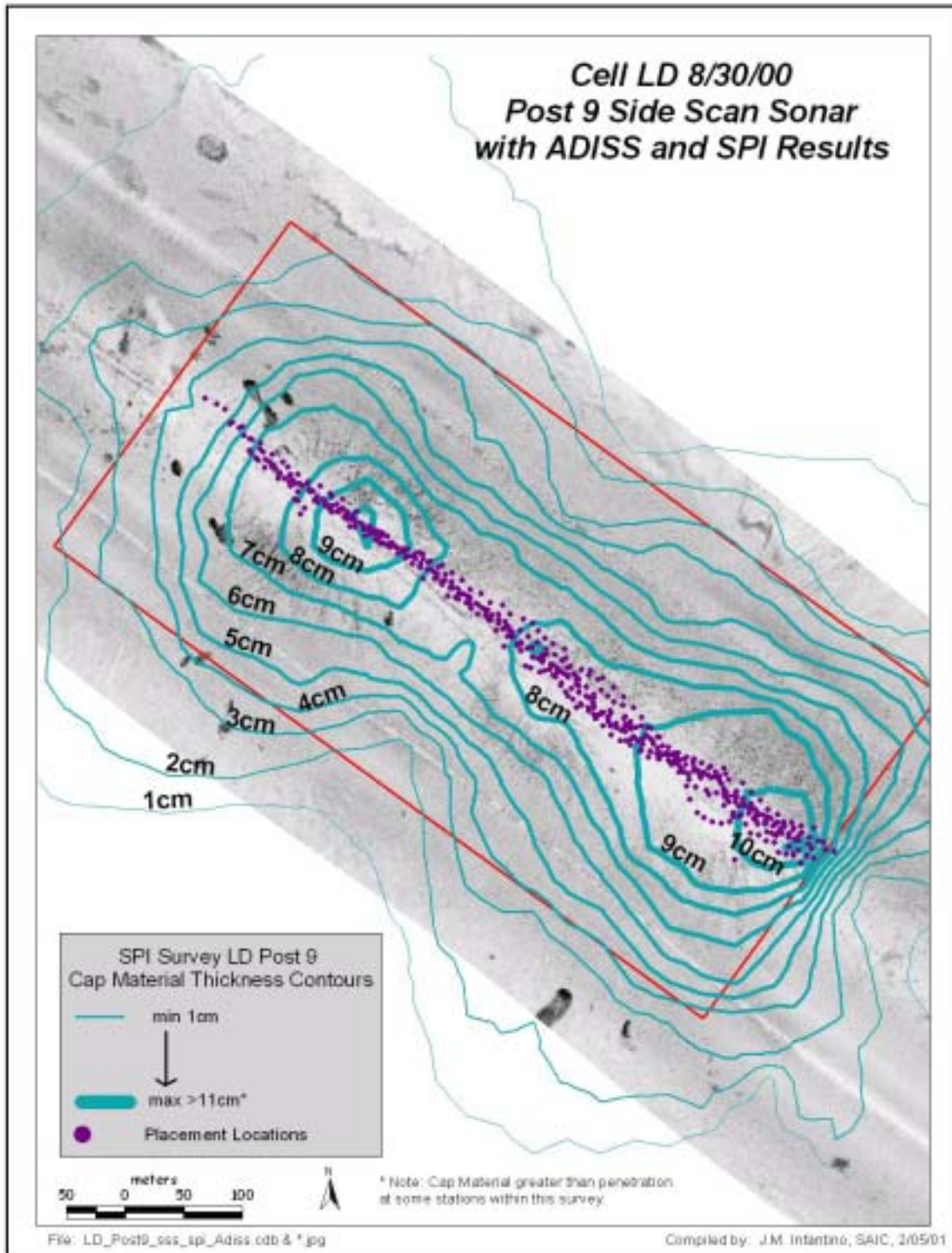

Figure 3-69. Side-scan sonar mosaic with SPI cap contours and ADISS dredge track – LD post 9

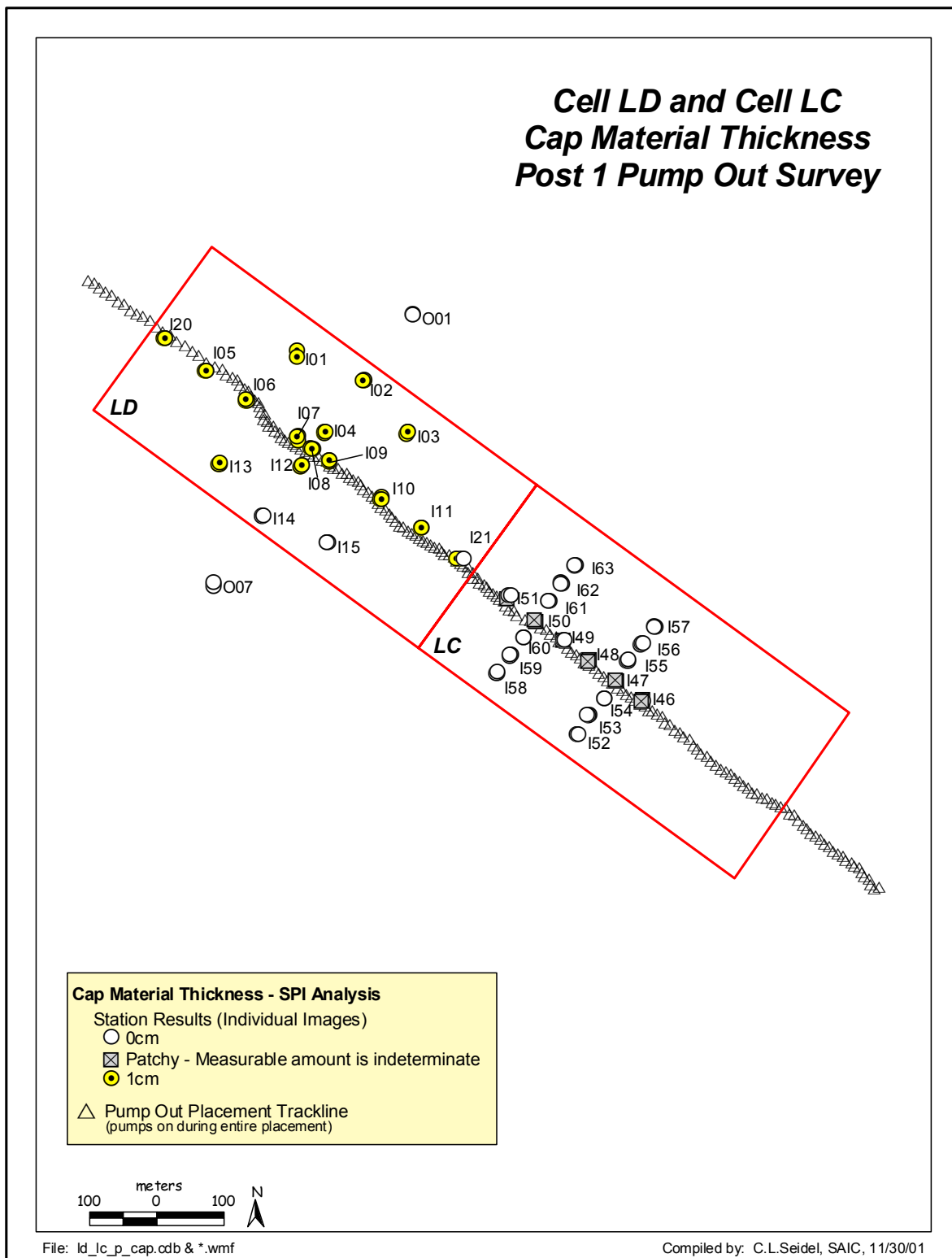

Figure 3-70. Track line of hopper dredge during pump-out placement in Cells LD and LC, and thickness of resultant cap layer in replicate images obtained at each station

Cell LD and Cell LC Shell Material Presence Post 1 Pump Out Survey

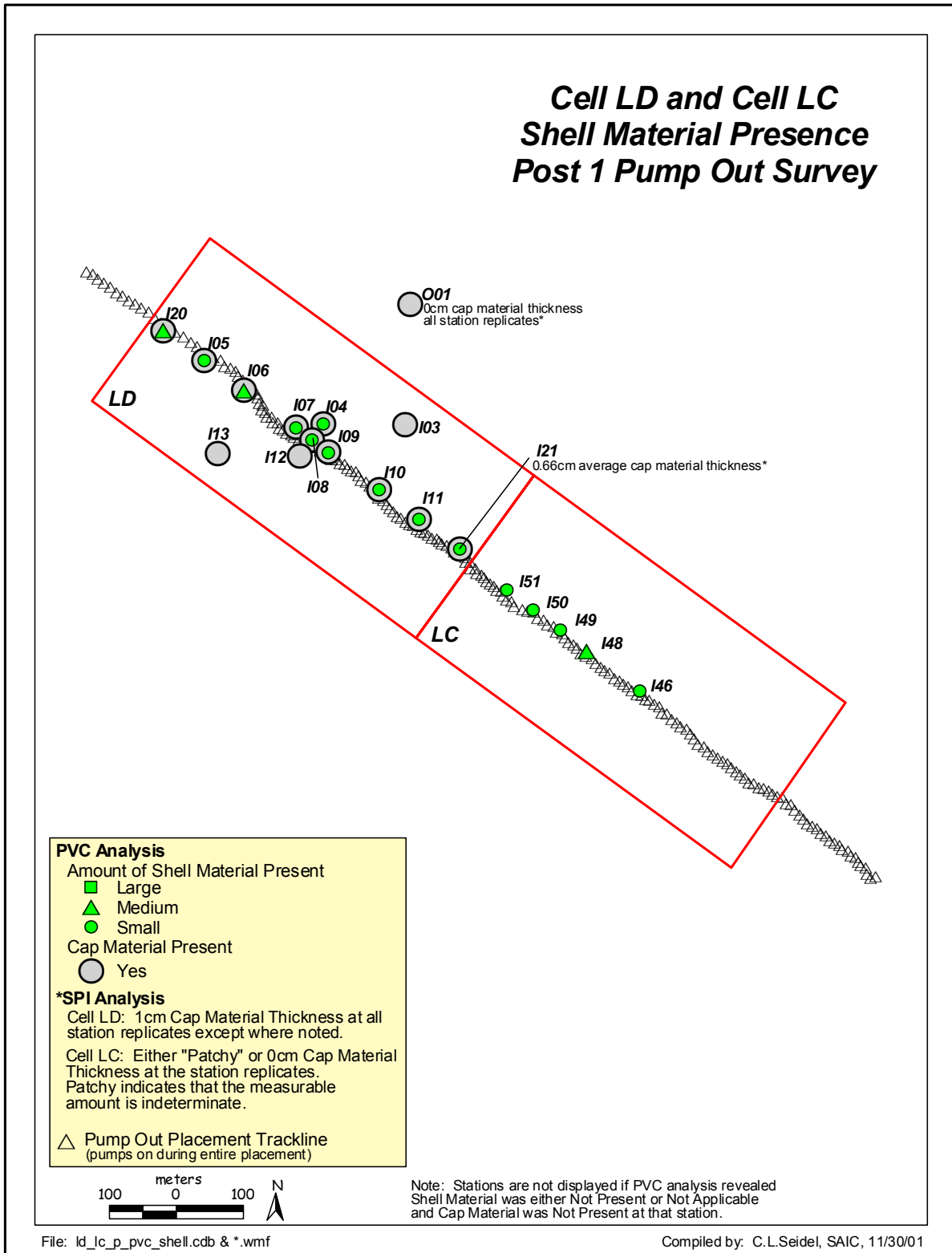

Figure 3-71. Extent of cap and shell material based on plan view camera (PVC) analysis – Post 1 survey in Cells LD and LC

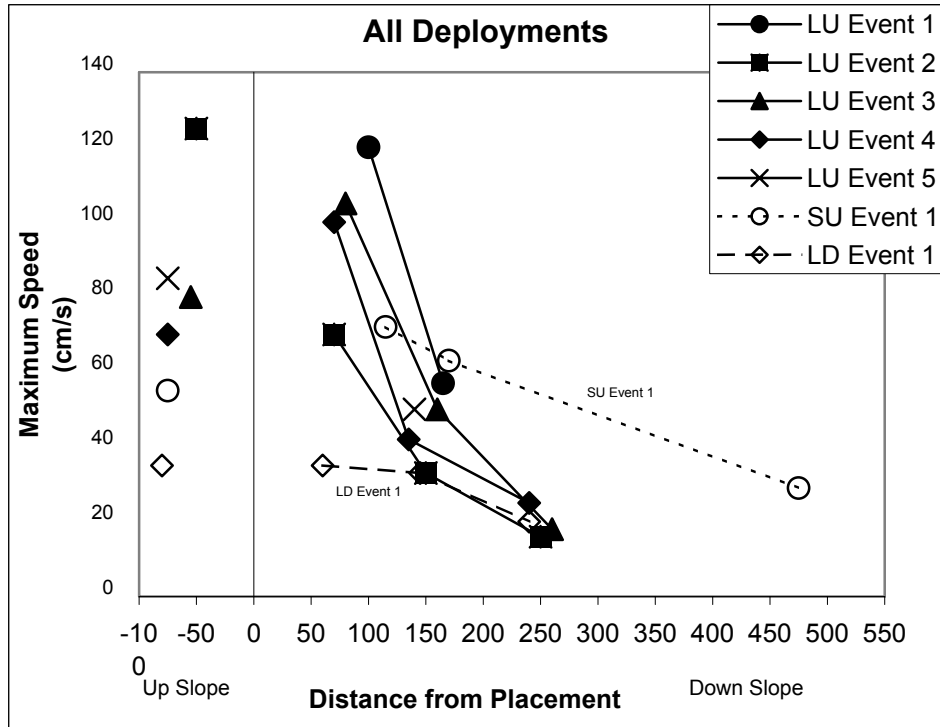

Figure 3-72. Observations of maximum surge current speed with distance away from cap load release point

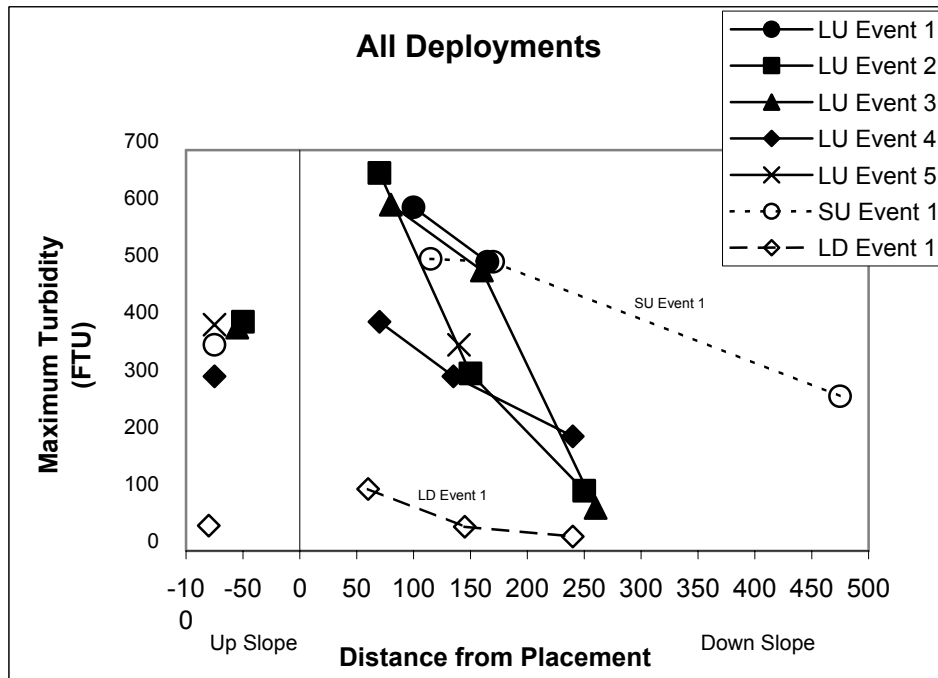

Figure 3-73. Observations of maximum turbidity with distance away from cap load release point

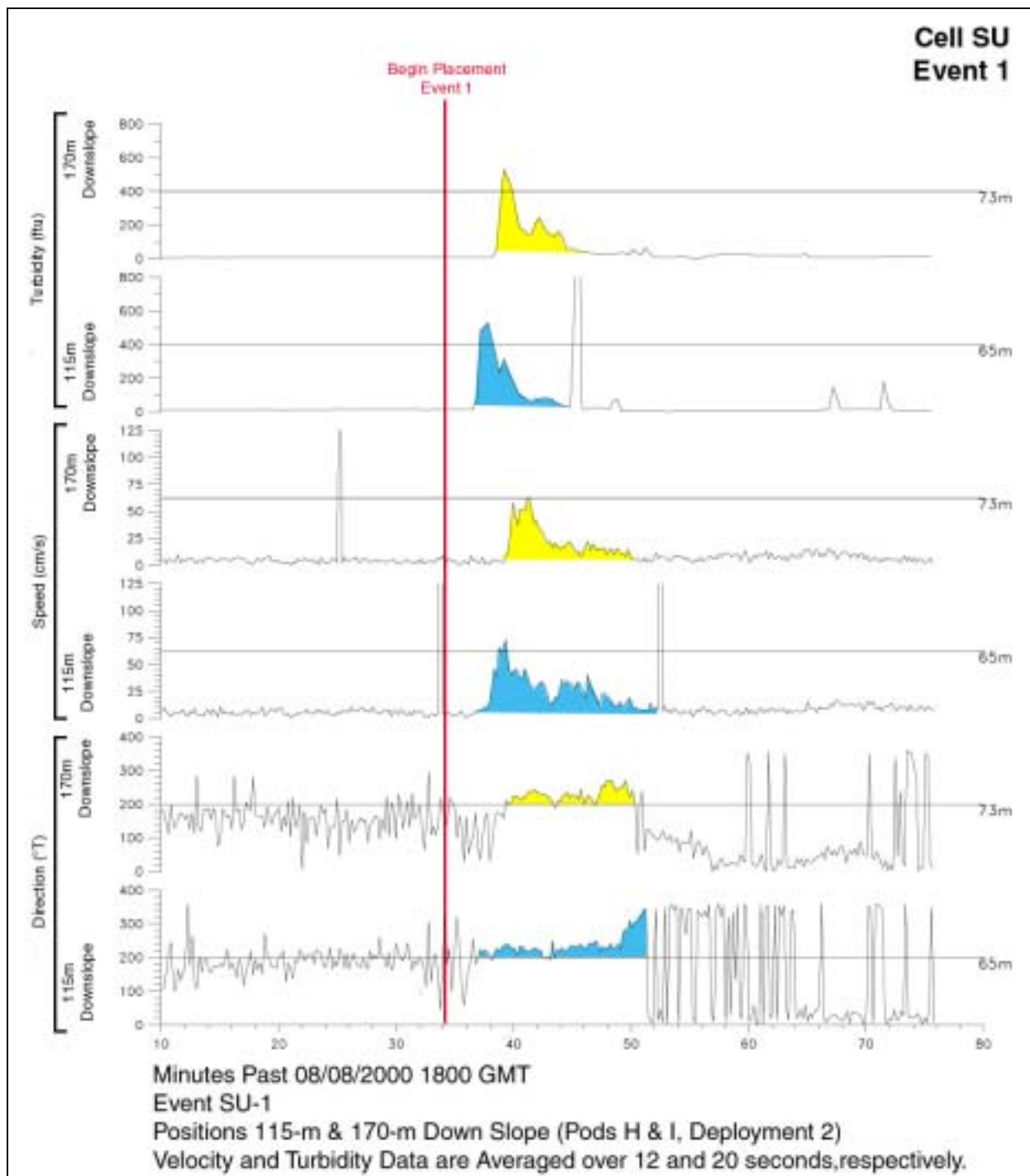

Figure 3-74. Example of data record from one of bottom instrument deployments (SU, Event 1) showing magnitude and duration of surge events observed. Shaded areas illustrate where event was distinguishable from background conditions

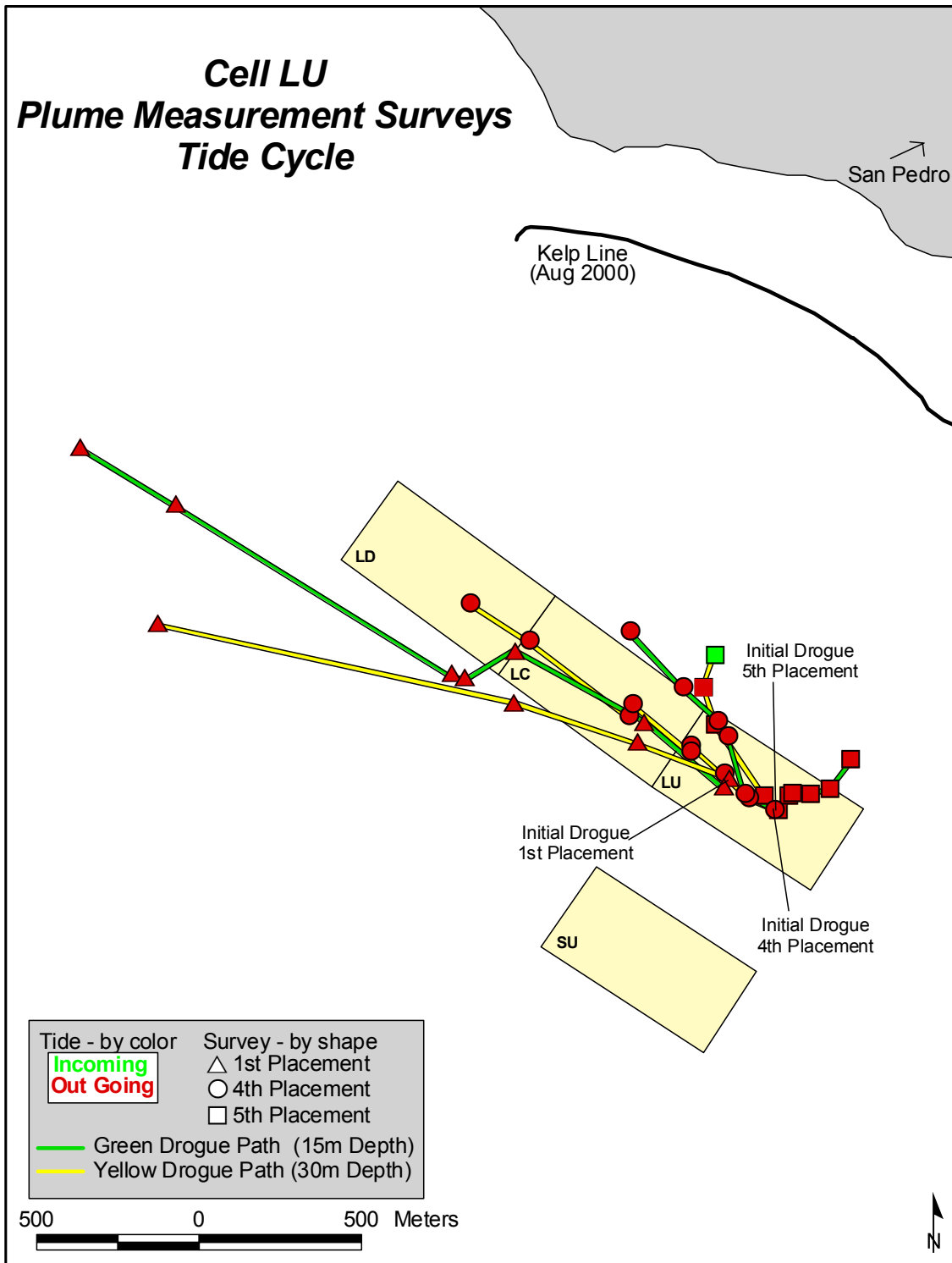

Figure 3-75. Drogue trajectories released at center of cell during plume tracking surveys at Cell LU

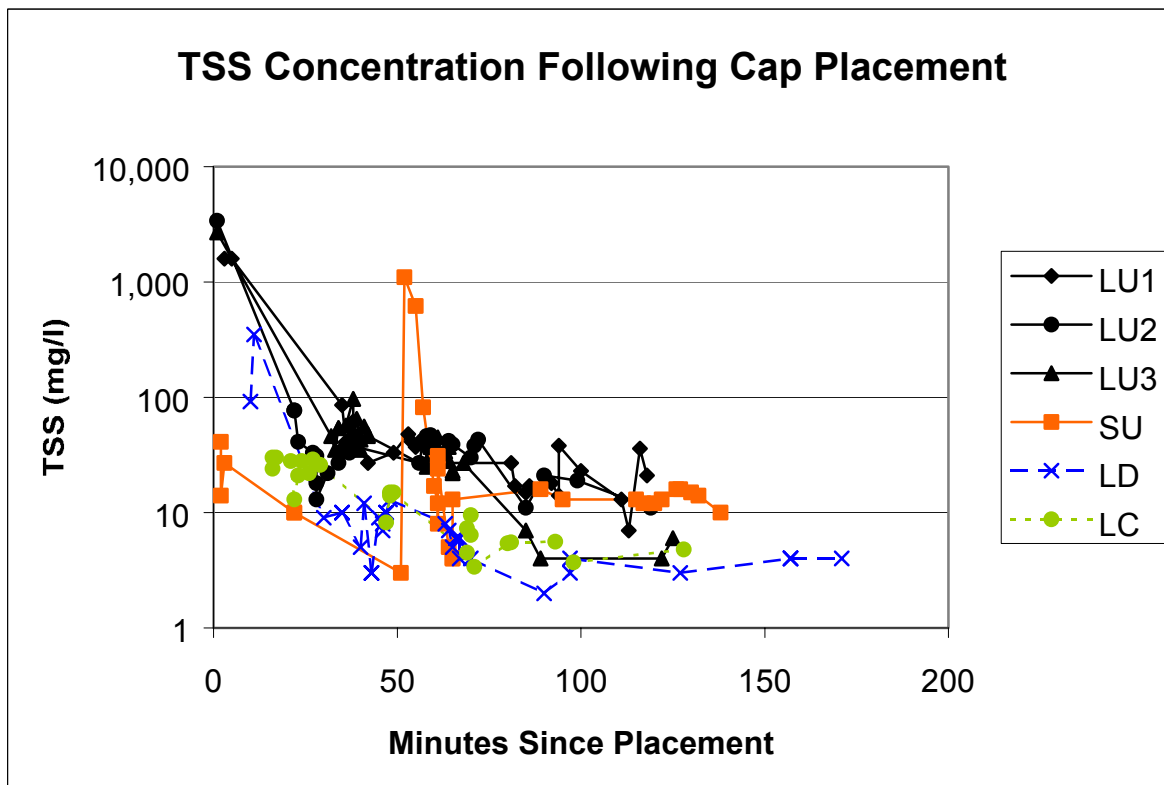
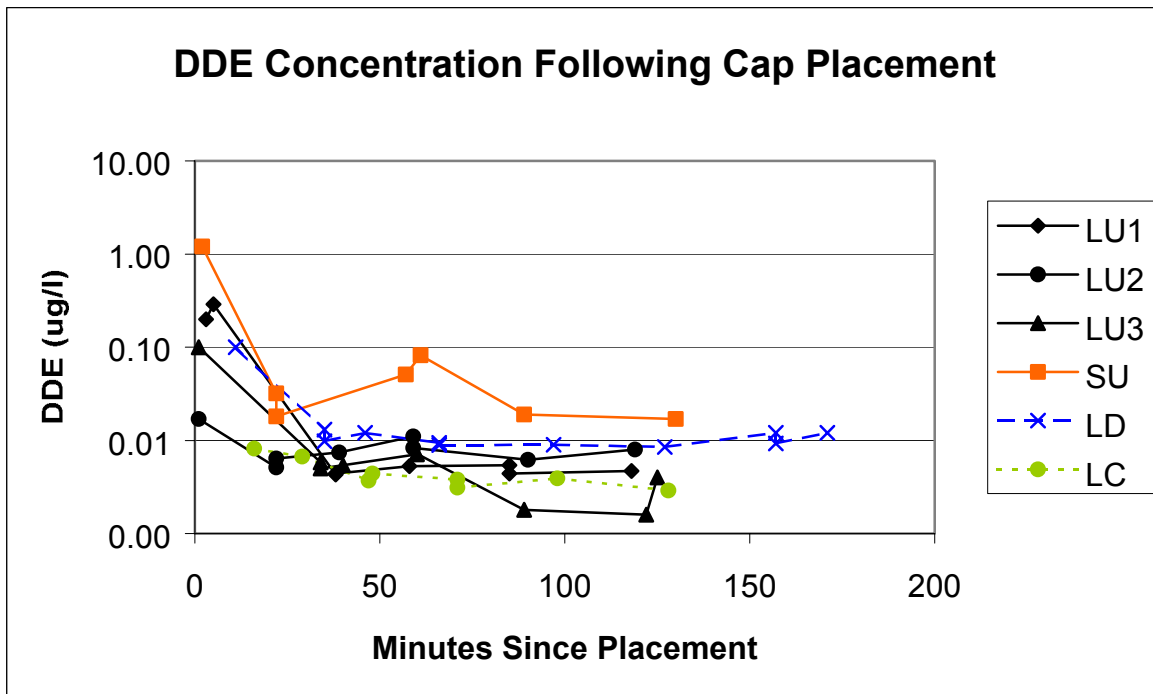

Figure 3-76. Plume DDE (top) and TSS (bottom) concentrations measured following cap placement in Cells LU, SU, LD, and LC. Note log scales

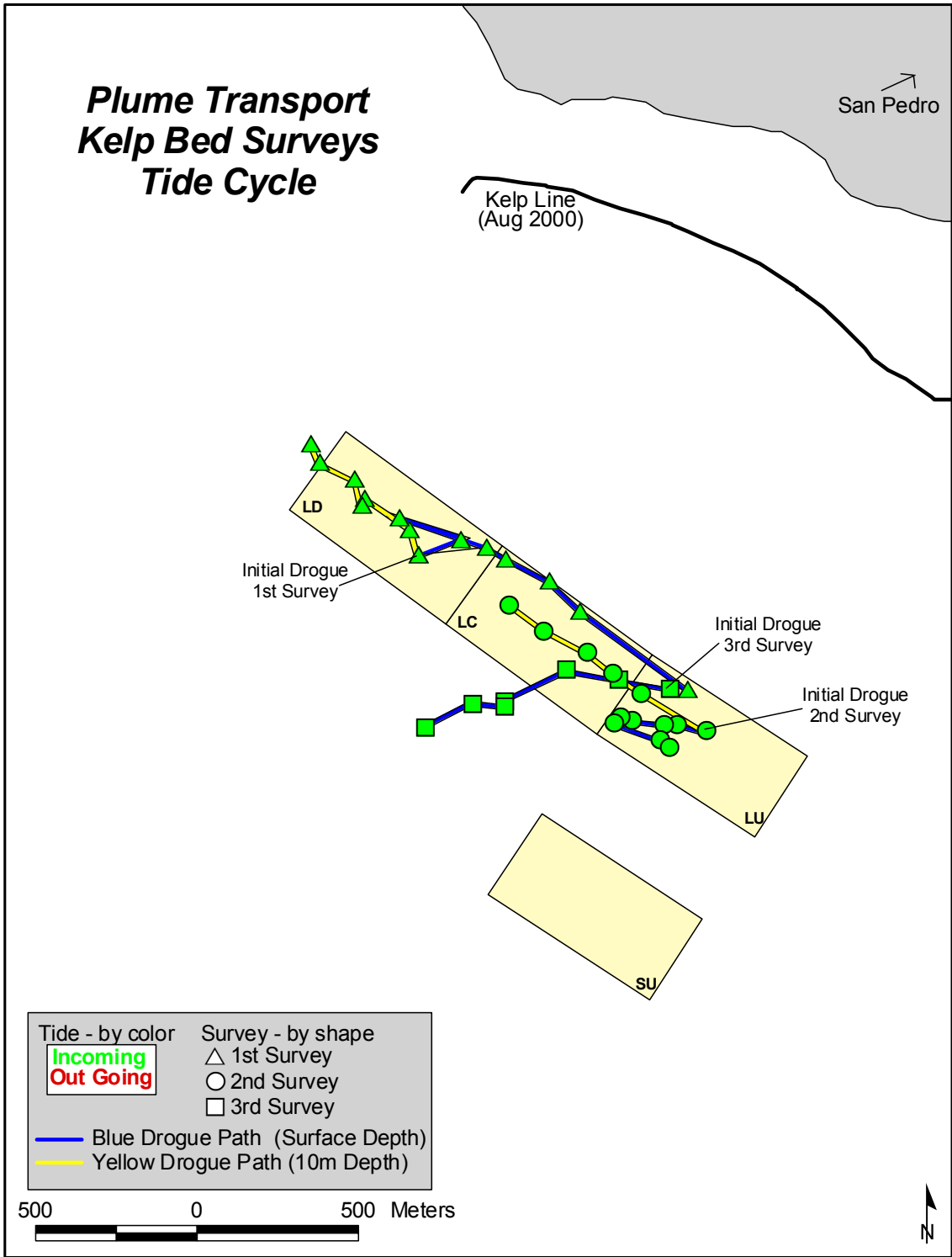

Figure 3-77. Drogue trajectories released in Cells LU and LD during plume tracking surveys

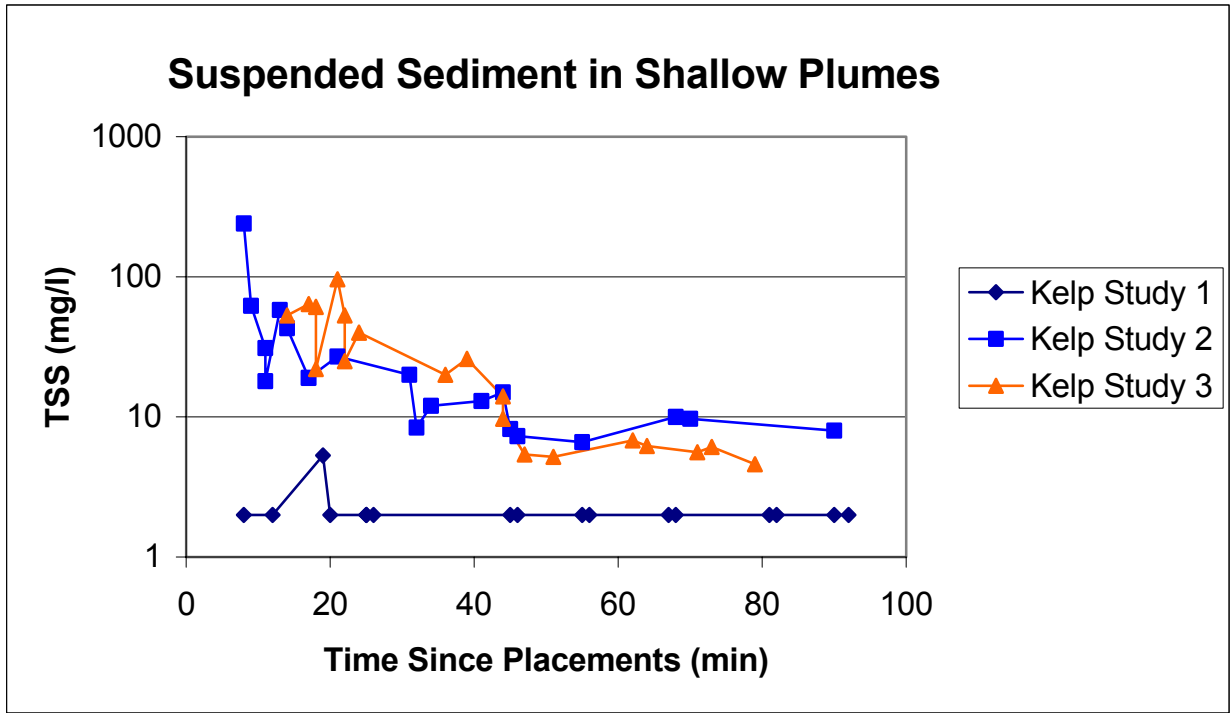

Figure 3-78. Composite plot of total suspended solids concentration for discrete water samples versus time since initiation of cap placement collected during CTD profiling operations of three cap placement events in Cells LD (Study 1) and LU (Studies 2 and 3) as part of assessment of potential kelp impacts

4 Cap Placement Modeling

- 4 Cap Placement Modeling 4-1
 - 4.1 Introduction..... 4-2
 - 4.2 Model Descriptions..... 4-3
 - 4.2.1 STFATE model for plume and surge characteristics..... 4-3
 - 4.2.2 MDFATE model for cap coverage and thickness..... 4-4
 - 4.2.3 D-CORMIX model for estimating bottom impact velocity during direct pump-out 4-5
 - 4.3 MDFATE Modeling for Cap Coverage and Thickness 4-6
 - 4.3.1 MDFATE applications 4-6
 - 4.3.2 MDFATE input 4-7
 - 4.3.3 Scenarios modeled..... 4-8
 - 4.3.4 MDFATE results – conventional placement in Cells LU and SU 4-9
 - 4.3.5 MDFATE results – spreading placements in Cell LD..... 4-14
 - 4.4 STFATE Modeling for Plume and Surge Characteristics..... 4-15
 - 4.4.1 STFATE applications 4-15
 - 4.4.2 STFATE input 4-15
 - 4.4.3 STFATE bottom surge current prediction results..... 4-16
 - 4.4.4 STFATE TSS predictions..... 4-18
 - 4.4.5 STFATE far field plume predictions 4-19
 - 4.5 D-CORMIX for Modeling Direct Pump-out 4-20
 - 4.5.1 Input..... 4-20
 - 4.5.2 Results 4-21
 - 4.6 Pilot Cap Study Implications for Full-Scale Cap Volume Predictions 4-21
 - 4.6.1 Limitations on measurement of pilot cap study sediment volume relationships..... 4-22
 - 4.6.2 Pilot study sediment volume relations 4-23
 - 4.7 Modeling Summary and Conclusions 4-25
 - 4.7.1 MDFATE..... 4-25
 - 4.7.2 STFATE..... 4-26
 - 4.7.3 Cap loss predictions..... 4-28
 - 4.7.4 D-CORMIX..... 4-29
 - 4.8 Modeling Recommendations 4-29
 - 4.8.1 Additional MDFATE modeling..... 4-29
 - 4.8.2 MDFATE model improvements 4-30
 - 4.8.3 STFATE model improvements..... 4-31
 - 4.8.4 Data collection..... 4-32

4.1 Introduction

Numerical model simulations of various aspects of cap placement were a critical component of the pilot project. ERDC engineers and scientists primarily used two ERDC-developed models, the Short-Term FATE of dredged material (STFATE) (Johnson and Fong 1993), and the Multiple-Dump FATE of dredged material (MDFATE) (Moritz and Randall 1995), to develop sediment fate predictions related to sediment dispersion and transport in the water column, and cap material buildup and placement, respectively. A third model, the Dredging Cornell Mixing Zone Expert System (D-CORMIX) (Doneker et al. 1995) was used to estimate the bottom impact velocity of the cap material during the direct pump-out process.

As part of the earlier in situ capping options study (Palermo et al. 1999), MDFATE simulations were used to estimate the volumes of dredged material required to cover 300 by 600-m cells with a given cap thickness. For the pilot study, MDFATE was used again to compute required volumes, both in the hopper and in the channel, to cover the target cells, LU and SU, with 15 cm of cap material. MDFATE was also used to compute the area covered by both individual and multiple placements. The information on cap thicknesses and area coverage was needed to make decisions on the spacing and location of the various monitoring activities such as the spacing and extent of the SPI stations and cores. MDFATE was used to assist in computing individual spacing and placement patterns within a given cell that would result in the desired cap thickness. Finally, a major goal of the pilot cap study was to determine how accurately MDFATE could predict cap extent and thickness.

The STFATE model was used to predict the fate of the plume that remained in the water column, the impact velocity of the descending jet, and the bottom surge velocity. In addition, because of concern that the plume might adversely impact the inshore kelp beds, a STFATE simulation was conducted to predict the path and TSS concentrations in the water column from a single placement of Queen's Gate cap material. The TSS data were used to make a qualitative estimate of potential impact to the kelp beds. There was also concern over cap material placement impacts on the Whites Point sewage outfalls. However, the MDFATE predictions of cap thickness showed no accumulation at the outfall locations, so no STFATE simulations were made to predict water column plume tracks and concentrations in the direction of the outfalls.

The ability of the STFATE model to accurately predict the various aspects of the capping process was also of interest. The bottom surge velocity is one of the most easily and accurately measured aspects of the aquatic portion of the cap placement process and is directly responsible for both potential resuspension of the EA sediments and the ultimate cap extent. Therefore, prior to cap placement several STFATE simulations were also conducted to estimate the velocity of the bottom surge. This information was used to assist in locating the placement of the bottom-moored current meters. After the cap placement operation, additional

STFATE simulations were conducted to compare measured surge velocities with STFATE predictions based on the actual conditions of the placements. Comparisons of water column plume dimensions and TSS concentrations with field data were also made.

The remainder of this chapter provides brief descriptions of the STFATE, MDFATE, and D-CORMIX models, discussions of the capping scenarios simulated, primary input data, and results and comparisons to field measurements where appropriate for each model. The STFATE model is described first, because the MDFATE model is based on the STFATE model. However, because the MDFATE model was by far the most used model and much of the STFATE input for this study was developed from the MDFATE input, the discussion of MDFATE scenarios, input, results, etc., are provided next, followed by the discussions of STFATE and D-CORMIX results. Pilot study cap volume relations are described next with some discussions of implications for full-scale cap volume predictions. The chapter concludes with a summary of the modeling activities and some recommendations. A full description of the dredged material fate modeling activities completed for the pilot study can be found in Appendix K.

4.2 Model Descriptions

4.2.1 STFATE model for plume and surge characteristics

STFATE simulates the process of placement of a single load of dredged material from a hopper dredge or barge. Field evaluations by Bokuniewicz et al. (1978) and laboratory tests by Johnson et al. (1993) have shown that the placement of dredged material generally follows a three-step process (Figure 3-1): (a) convective descent during which the material falls under the influence of gravity, (b) dynamic collapse, occurring when the descending cloud or jet either impacts the bottom or arrives at a level of neutral buoyancy, in which case the descent is retarded and horizontal spreading dominates, and (c) passive transport-dispersion, commencing when the material transport and spreading are determined more by ambient currents and turbulence than by the dynamics of the placement operation.

Model development in this area was initiated in the early 1970s with the work of Koh and Chang (1973) and was continued with developments by Brandsma and Divoky (1976), Johnson (1990) and Johnson and Fong (1993). However, deficiencies remained in the model. Research in the USACE Dredging Research Program (DRP), which resulted in the STFATE model, was directed at removing many of these deficiencies, e.g., inadequate representation of placement from hopper dredges, the inability to represent the nonhomogeneity of placement material, the inability to model placements at dispersive sites, the inadequate representation of the bottom collapse phase, and the inability to model placement over bottom mounds.

STFATE still has a number of limitations that reduce its ability to accurately model the placement process. The more important limitations that have the greatest impact on this project are detailed here. A major limitation in the ability of STFATE to predict the fate of sediments suspended in the water column for periods of several hours is the model's use of time invariant currents, i.e., in a given STFATE model simulation the ambient current is constant over the period of the simulation. In addition, before the effort discussed herein was conducted, only a unidirectional depth-averaged current could be entered for placement at sites with variable bathymetry. Thus, the ability of STFATE to simulate the TSS plume was reduced when the currents varied significantly through the water column or had a strong tidal influence, which causes them to change direction over short time periods (1 to 2 hr). Before making the model runs presented here, STFATE was modified to allow for vertical shear in the ambient currents over the Palos Verdes Shelf. However, the time invariancy limitation remained.

STFATE has two other limitations that influence the accuracy of predictions for this application. First, STFATE does not accurately model the bottom dynamic collapse phase over variable bathymetry. Second, no erosion of bottom sediments by the bottom surge is allowed in STFATE, and once sediment is deposited on the bottom it is assumed to remain there. A somewhat more detailed description of STFATE and its limitations can be found in Appendix K and Clausner et al. (2001), with a full description of the model provided by Johnson and Fong (1993).

4.2.2 MDFATE model for cap coverage and thickness

MDFATE simulates the mound developed by multiple placements of dredged material from a hopper dredge or barge. MDFATE was developed under the USACE Dredging Research Program (Hales 1995). The MDFATE model was formerly known as Open Water Disposal Area Management Simulation (ODAMS) Program (Moritz and Randall 1995). MDFATE is a site management tool that bridges the gap between the STFATE model (Johnson and Fong 1993), which simulates the placement of a single load of dredged material, and the Long-Term FATE of dredged material (LTFATE) model (Scheffner et al. 1995) which predicts the long-term stability (days to years) of dredged material mounds.

In MDFATE, the suspended solids and conservative tracer portions of STFATE are removed so the modified STFATE sub-model within MDFATE only simulates the convective descent and dynamic collapse processes. The LTFATE model combines hydrodynamics (waves, currents, and tides) and sediment transport algorithms to predict the stability of dredged material mounds composed of grain sizes ranging from small gravel/coarse sand down to coarse silts. MDFATE uses modified versions of STFATE and LTFATE to simulate multiple placement events at one site to predict mound building and can be used to determine if navigation hazards are created, to examine site capacity and mound stability, to design capping operations, and to conduct long-term site planning. During the earlier capping study (Palermo et al. 1999), a stand-alone version of the LTFATE model was used to model cap stability during storms.

The following paragraph highlights major MDFATE limitations that impact this project. Clausner et al. (2001) gives a more detailed description of MDFATE and its limitations.

MDFATE has all the STFATE process limitations (e.g., time invariant currents over the duration of individual simulations and no estimates of resuspension of existing bottom material). Also, like STFATE, MDFATE calculates a rate of material leaving the vessel based on an assumption that the rate is relatively uniform. The ADISS data (Appendix J) clearly indicated that the material leaves the vessel at a nonuniform rate, particularly for material placed in the spreading mode. See Appendix K for a more detailed discussion of MDFATE limitations.

In addition to conventional bottom releases where the vast majority of the material descends rapidly to the bottom, MDFATE can simulate capping using a spreading (particle settling) type of placement. During this spreading placement, all the vertical kinetic energy of the material coming out of the dredge (or barge) is dissipated in the upper water column, allowing the sediments to experience passive transport, diffusion and settling of solids based on individual particle fall speed. The MDFATE capping module can simulate two spreading placement methods. One method is the slow release of cap material through the slightly cracked (0.3 to 0.6 m) split hull of a barge/hopper dredge. The second method simulates hydraulic pipeline discharge from a hopper dredge reversing its dredge pumps. The spreading particle settling mode portion of MDFATE is not as sophisticated as the conventional placement mode, as it does not allow a realistic simulation of the dredge track line, nor does it allow multiple sediment types to be modeled.

4.2.3 D-CORMIX model for estimating bottom impact velocity during direct pump-out

The Cornell Mixing Zone Expert System (CORMIX) was specifically developed to provide a predictive tool for conventional or toxic pollutant discharges into waterways. The CORMIX modeling system was originally developed to address bottom discharges with low suspended solids concentrations or buoyant bottom discharges. Such discharges are typically associated with municipal wastewater, industrial waste outfalls, cooling water, and freshwater releases in saline environments. Dredged placement operations, on the other hand, typically involve surface or near-surface discharges, frequently with high suspended solids concentrations. Consequently, the original CORMIX package was not directly applicable to dredged material placement operations (Chase 1994).¹

The Dredging Operations Mixing Zone (DROMIX) program, now known as Continuous Discharge FATE (CDFATE), was developed to adequately address the need for modeling surface or near-surface dredge discharges (Havis

¹ Chase, D. (1994). "Dropmix user's manual," draft report prepared for the Environmental Laboratory, U.S. Army Waterways Experiment Station, Vicksburg, MS.

1994). The DROP MIX program takes data describing typical dredge discharge activities, and utilizes the CORMIX modeling system (with slightly-modified output routines) to predict water column concentrations and dispersion of the plume into the water column resulting from pipeline discharges and other discharges of a continuous nature into waterways. The DROP MIX routines transform the dredge discharge information (negatively or neutrally buoyant surface discharge) into an equivalent, mirror-image, positively or neutrally buoyant, bottom discharge scenario with sedimentation.

In an effort to better model the dense fluid mud layer resulting from surface discharges of dredged material slurries from pipelines, Doneker et al. (1995) developed CD-CORMIX, now known as D-CORMIX. D-CORMIX models the transport of the fluid mud, entrainment of water into the fluid mud layer (growth and dilution), and sedimentation of particles from the fluid mud layer.

The D-CORMIX program was used in a limited manner during the pilot study to estimate the impact velocity of the cap material jet with the bottom during direct pump-out through the dredge drag heads at various depths. This program predicts the time for the jet to descend through the water column and the size of the plume as a function of distance from the source. This is the only model for estimating the growth and movement of discharge plumes that provides sufficient output to compute the velocity of a jet as it impacts the bottom. Doneker et al. (1995) discuss the D-CORMIX program, its capabilities, and outputs in detail. The impact velocities computed from the D-CORMIX simulations were used as part of the decision for determining if direct pump-out should be used during the capping operation.

4.3 MDFATE Modeling for Cap Coverage and Thickness

4.3.1 MDFATE applications

MDFATE modeling simulations were made to predict the cap thickness and extent at Cells LU, SU, and LD (Figure 1-4 or Figure 3-8) as a function of sediment characteristics (primarily grain-size distribution), hopper dredge operating characteristics (speed, heading, duration of placement), the volume and bulk density of material in the hopper and on the bottom, and ambient currents. A number of MDFATE scenarios were conducted at various times prior to, during, and following actual placement, respectively. These three primary phases of MDFATE simulations are referred to as predictive, operations, and hindcast.

The primary model results of interest included maximum mound thickness and cap extent. Expected cap footprint and thickness from a single placement were principle simulations during the predictive, preplacement phase. This information was used to design the monitoring program. Later, MDFATE

simulations of full cap placements were conducted to assist in determining the volume of cap material required.

Immediately prior to and during the initial placements, MDFATE operational simulations were conducted to fine-tune monitoring activities, confirm prior estimates of spacings between placements, and to confirm that the MDFATE predictions were reasonably close to the actual mound characteristics as determined by monitoring. This suite of MDFATE predictive simulations estimated offset (the distance and direction between where the cap material was released and where it came to rest on the seafloor) to insure cap material did not land directly on the bottom-mounted instruments. Additionally, information from these simulations provided confidence that the cap placed during the pilot study would meet design expectations.

The final sets of MDFATE hindcast simulations were conducted using monitoring data of actual cap thickness and extent to determine how well MDFATE could model actual cap dimensions and its applicability to a full-scale cap. These data were also used to update various coefficients needed to predict required cap volumes for full-scale capping.

4.3.2 MDFATE input

Required inputs for the MDFATE model included Palos Verdes Shelf bathymetry, environmental conditions such as waves and current, sediment characteristics, hopper dredge dimensions, and details on the placement (duration, volume, heading, etc). Most of the input data remained constant between a series of MDFATE simulations. These constant data typically included vessel characteristics, bathymetry, model grid spacing, water density, and wave data. Input data that did generally vary included volume of dredged material, hopper dredge velocities, and sediment characteristics. Only selected input data are discussed in this chapter, primarily those associated with the hindcast simulations.

A wide range of scenarios was modeled in the predictive phase at the start of this project to examine potential ranges of possible impacts for conventional placements in Cells LU and SU because exact sediment properties, vessel loads, placement areas, vessel direction, heading, speed, and current were unknown. The matrix of predictive MDFATE simulations is provided in Table 4-1. As certain unknowns became more defined, the simulated scenarios became more focused. During the operations simulations, many of the input values related to dredge characteristics came from ADISS or NATCO with some dredged material characteristics computed from analysis of hopper samples. Input for the hindcast simulations used the best data available including monitoring data from SPI and cores. Table 4-2 summarizes the majority of the MDFATE input parameters used. Table 4-3 summarizes sediment data for the predictive and operational simulations, while Table 4-4 summarizes sediment data for the hindcast simulations. Full details on input parameters are provided in Appendix K.

4.3.3 Scenarios modeled

This section briefly describes the cap placement scenarios modeled using MDFATE during the pilot project.

Conventional placement scenarios simulated (Cells LU and SU).

Predictive. Prior to the capping operation, model sensitivity tests were performed for several dredge velocities: 0, 0.5, 1.0, 2.0, and 3.0 knots, generally with the dredge moving from east to west. The nominal duration for the dredge to empty the conventional loads was estimated to be 3 min based on load curves from the Queen's Gate Channel Deepening Project. Table 4-1 summarizes the matrix of MDFATE simulations that were conducted for conventional placement prior to actual operations. The predictive simulations showed that acceptable cap dimensions would occur with the dredge nearly stationary. Also, a stationary dredge greatly simplified the deployment of bottom-mounded instruments for field data collection.

Operational and Hindcast. During the operational simulations, conventional loads were placed with the dredge nearly stationary. For hindcast simulations, the dredge moved at the velocity determined by ADISS. While the initial operational simulations continued to use 3-min placement durations with the dredge heading east to west, later operational simulations and the hindcast simulations used actual data on vessel velocity, duration, volume, etc., collected by ADISS. Chapter 2 and Appendix K provide some additional details and a summary of loads, velocities, durations, etc. Note that the heading used for the model was based on the vector between the placement start and end-point, while in reality, the dredge track showed significant deviations from a straight line for some loads due to a combination of wind and currents.

Spacings between adjacent loads were determined by a combination of the MDFATE simulations from the earlier study (Palermo et al. 1999) and practical considerations. The earlier studies assumed the dredge would have a significant forward velocity, thus lanes were set up. Lane spacings of 60 to 75 m were used. The decision to use conventional placements was primarily to facilitate the monitoring activities. The selected spacing of 75 m between adjacent placements was within the range of spacings already simulated and also conveniently divided the 300-m-wide cell in to four even sections. Also note that this 75-m spacing is less than one hopper dredge length (83 m) and is roughly five hopper dredge widths. Figures 3-50 through 3-55 provide good examples of the relative hopper placement spacings and dredge tracks during placement as do Figures 3.2-9 and 4.2-6 in Appendix J.

Scenarios for spreading placement (Cell LD).

Predictive. Model sensitivity tests were performed for the spreading mode by varying the input grain size (i.e., the D_{50}) between 0.33 and 0.4 mm. MDFATE allows only a single grain size for this type of simulation, current speed and direction, and placement depth. The load for each simulation was 1,987 m³ and the vessel speed was 1.5 knots with a north heading. MDFATE

only allows north/south or east/west headings in the spreading mode. This simulation was conducted with three tracks, each 500 m long and separated by 30 m. The duration for the dredge to empty the load was 30 min with a vessel speed of 1.5 knots. These values were based on experience during the 1997 New York capping project (Lillicrop and Clausner 1998) using a similar NATCO dredge and 0.4 mm sand.

Hindcast. As described in the SAIC (2001) monitoring report, it was difficult for the dredge to achieve the goal to evenly release all the dredged material as it passed over the cell. The ADISS data (SAIC 2001) showed that the majority (65 percent) of the material as placed in the first one-third (S.E. portion) of cell LD, with 17 percent in the center and northwest one-thirds of the cell. Unfortunately, MDFATE can only simulate an even rate of release, at a single heading that must be either north to south or east to west. For the hindcast simulations in LD, the center point of the placement (from a time standpoint) was computed along with an average velocity. The individual placements were then simulated separately using an east to west placement direction (270 deg).

4.3.4 MDFATE results – conventional placement in Cells LU and SU

The results described in this chapter deal almost exclusively with the hindcast simulations. Results from the predictive and operational simulations are described in detail in Appendix K. A summary of the results from the hindcast simulations is provided in Table 4-5. Included in Table 4-5 are the cell in which the material as placed and the number of placements simulated (e.g., LU1 is a simulation of the first placement in LU, LU5 is a simulation of the first five placements in LU, etc.), the sediment characteristics used in the simulation (as described in Table 4-4), the maximum cap dimensions as defined by the 1-cm contour (L x W refers to the alongshore and shore perpendicular cap dimensions), the maximum cap thickness from the simulation, the maximum cap thickness as determined by SPI, and the percent of the volume of material placed that was retained on the bottom within the model grid boundaries.

Prior to the discussions of the results, a short description of the terms placement, load, and volume is in order. In common USACE terminology, a load is the full mass (or weight) of dredged material inside the hopper bin when the dredge has finished loading. In addition to the weight of dredged material (as determined by the change in dredge displacement), the load of dredged material also occupies a certain volume inside the hopper dredge. Because the weight of the dredged material, or load, is more easily determined than the volume, the dredging contractor routinely calculates the load in tons. However, the dredging contractor is paid based on the volume of dredged material removed from the channel. Thus the dredging contractor often determines the relationship between the volume and weight of the channel material, i.e., the bulk density of the channel sediments. By knowing the bulk density of the material in the channel, the bulk density of the material in the hopper, and the relationship between the two, the contractor can convert the load in tons to an in-channel volume. When the loading operation is complete, the hopper dredge transports the load to the placement site where the load is placed (a single placement). The terms

placement and load are interchangeable, but for this report the term placement is used.

Single Placements (LU1 and SU1). For the initial placements in Cells LU and SU, the maximum cap thicknesses predicted by MDFATE (maximums in the 2-3-cm range) were generally 3 cm less than the maximum SPI measured cap thicknesses near the placement locations. Figures 4-1 and 4-2 show the single placement MDFATE simulations compared to the SPI measured cap thicknesses for LU and SU, respectively. This difference between measured and predicted is likely because SPI cap thickness measurements included the resuspended layer as part of the cap. These estimates of EA layer depth of disturbance at the point of impact were estimated as a minimum of 2.5 to 3 cm. Figure 4-3 shows the estimated depth of EA layer disturbance following the LU1 placement. This observation that the measured SPI cap thickness includes the depth of EA disturbance is strengthened by the fact that the volume of the cap as estimated by the SPI thickness measurements was considerably greater than the volume placed or estimated by MDFATE. In addition, random variations such as nonuniform placement rates cannot be modeled, which may also contribute to the difference between SPI and MDFATE results. The mound extent (as defined by the 1-cm contour) generally showed good agreement between SPI and MDFATE. Mound extent (based on the 1-cm contour) predicted by MDFATE for LU1 was about 250 m in the along-shelf direction, compared to SPI measurements of about 245 m. For SU1, the MDFATE maximum mound extent in the along-shelf direction was 285 m while the SPI maximum extent was 325 m. The larger diameter cap mound from the SU1 placement, compared to the LU1 cap from the LU1 placement, was likely because at the greater depths found in Cell SU, more water is entrained in the descending jet, resulting in a larger diameter impact cloud and hence, a larger cap.

To have the mound locations from the MDFATE single placement simulations agree with the actual locations required eliminating the residual (nontidal) current from the simulations. See Appendix K for details. MDFATE single placement simulations required not including residual currents to have the predicted mound location agree with the actual location. The MDFATE program requirement to simulate any residual current for one full week combined with older versions of LTFATE sediment transport routines and limited data on critical shear stresses, results in excessive transport of mound sediments when sizeable residual currents are used.

Slope effects for single placements as shown by SPI were modest. MDFATE did not model slope effects for single loads particularly well (i.e., the MDFATE model predicted more material depositing downslope and less material depositing upslope than shown by SPI measurements). The nonuniform rate of release is one possible explanation of these data.

Multiple Placements in LU and SU. MDFATE simulations were made of all the multiple placements to correspond to the point at which monitoring was done to provide ground truth data: after 5, 25, 45, and 71 placements in Cell LU and after 5 and 21 placements in Cell SU. Several of these placements are discussed here, and additional details are provided in Appendix K.

The results from the multiple simulations were reasonably consistent, allowing some general observations to be made. First, the simulations that best agreed with the overall footprint as measured by STFATE used no tidal currents. Residual currents were never used for any of the multiple placement simulations because of the excessive offset problems noted in the predictive and operational single load simulations. The best simulations all included stripping of the sediment fractions. Those simulations where no stripping was specified resulted in mounds with an excessive thickness of the central mound peak. The simulations with stripping and no tidal currents, however, still had a pronounced central mound peak that was thought to exceed the actual cap thickness by as much as 10 cm or more. These peaks were of limited extent, perhaps 50 to 100 m across, and are thought to be remnants of the five loads placed at the center of Cells LU and SU initially. The center of the mound also received contributions of dredged material from many of the surrounding placements. These contributions tended to build up the center of the mound when combined with the five initial placements made at the center of each cell. It is suspected that in the field, the surge from surrounding placements tend to resuspend and reduce the thickness of the central cap peak. Because MDFATE does not resuspend already placed material, these peaks remained in the model results when no tidal currents were included. Other than the excessive central peak, the remainder of the cap deposit predicted by the simulations (with no currents and with stripping), within and around the cell boundary, agreed well with the SPI observations after the depth of EA sediment disturbance was subtracted from the SPI measured cap thickness. Also, the no tidal current simulations provided much more symmetrical caps (i.e., circular caps), than the simulations with tidal currents. These circular, no tidal current simulated mounds more closely matched the SPI observed mound geometries.

When tidal currents were included in the MDFATE simulations, the peak in the center of the cell was less prominent without the mound as a whole being offset and matched the probable maximum cap thickness much better. However, the rest of the mound appeared to be too thin as the remaining cap material deposit was stretched in the direction of the major tidal current directions, NW to SE, and reduced in the onshore/offshore direction. The mound did not move as it did for the residual currents because the tidal currents only act for 3 hr at a time, as opposed to 7 days or more for residual currents, and tidal currents change direction every 3 hr, primarily acting in the NW to SE directions. For the simulation of the 45 and 71 placements in Cell LU, including tidal currents resulted in an overprediction of the maximum extent of the cap in the along-shelf direction. SPI images were not taken outside the cell boundaries for the LU5 and LU25 simulations, so this topic cannot be addressed for those simulations.

The SU simulations showed the sensitivity of MDFATE to the volume of the material in the vessel bin. This aspect needs to be examined before additional modeling is done if possible. Details can be found in Appendix K.

Lack of good core data made accurate comparisons for the full placements in Cells LU and SU difficult because at the center of the mound, virtually all of the cap thicknesses measured by SPI were greater than the depth of penetration.

Slope effects for the full cap placements as modeled by MDFATE were evident but not extreme, with the deeper cell, SU, showing a greater impact of slope. Typically, the center of the mound and downslope contours were displaced about 30 m downslope in the MDFATE simulations.

Maximum extent of the cap as determined from SPI agreed well with the location of the predicted 1-cm contour from MDFATE simulations for the nontidal current simulations.

Last, but not least, like in the single placements, a much better match between the MDFATE predictions and the SPI measured cap thickness was realized by subtracting the EA depth of disturbance from the SPI measured cap thickness.

LU5 Simulations. As previously described, the stripping, no tidal currents MDFATE simulation best matched the SPI observations (Figure 4-4). However, the simulated maximum cap thickness, 18 cm, exceeded the SPI maximum observed thickness of greater than 8 cm. The simulation with stripping and tides reduced the maximum cap thickness to 13 cm (Figure 4-5), closer to actual, however, the outer contours did not match the SPI measurements as well as the nontidal simulations. Because no SPI measurements were taken beyond the cell boundary, it is more difficult to comment on the agreement outside the cell. The mound obviously extended beyond the cell boundary.

LU25 Simulations. Once again, the MDFATE simulation with stripping and no tidal currents best matched the SPI observations (Figure 4-6). Again the maximum predicted cap thickness, 28 cm, was considered to be too thick, but in the remainder of the mound, predicted thickness, adjusted for EA disturbance depth, matched the SPI thicknesses well. When tidal currents were included in the simulation along with stripping, the maximum predicted mound thickness was reduced to 17 cm, much closer to the SPI measured thickness of greater than 15 cm.

LU45 Simulations. The LU45 simulations with stripping and no tidal currents provided the best match with SPI observations. Like the other multiple placements with no tidal currents, a central mound peak developed, with a maximum thickness of 30 cm, and with the 20-cm peak having a diameter of 160 m (Figure 4-7). This 30-cm peak is not considered to actually develop as previously noted. Most of the cell had predicted MDFATE thickness of greater than 10 cm, with 15-cm thicknesses covering a large portion of the cell. Cap thickness as measured by SPI exceeded penetration depth in all cases, with the measured SPI thickness ranging from greater than 8 cm to greater than 15 cm. As noted in Chapter 3, Section 3.6.2, core data (primarily sediment chemistry) indicated cap thicknesses in the center of the cell (300 x 300-m area) in the 12 to 16-cm range of cap only sediments and cap plus mixed layer of 12 to 20 cm. The SPI measurements also showed up to 5 cm of cap extending up to 150 m from the cap boundary in all directions, which is matched well by the no tidal current simulation when the correction of EA disturbance depth is made.

When tidal currents were included (Figure 4-8), the maximum cap thickness predicted by MDFATE was reduced to 19 cm, with most of the cell having thicknesses in the 8 to 13-cm range, probably thinner than what actually occurred, but not by too much.

LU71 Simulations. The MDFATE simulations of the LU71 placements, which were meant to construct a 45-cm thick cap over the central portion of the LU cell, had only limited monitoring data collected following placement, including some far field SPI stations to determine maximum cap extent and limited cores. The LU simulation with no tides predicted a mound with a maximum cap thickness of 42 cm (Figure 4-9), while the corresponding simulation with tides predicted a maximum cap thickness of just over 30 cm (Figure 4-10). As in previous simulations, the no tides simulation significantly overpredicted the maximum cap thickness. In this case, the simulation with tides may also have overpredicted the actual maximum cap thickness. Core data estimated the cap thickness over the central portion of the mound as 16 cm. Adjusting for the estimated loss of cores due to bow wake (Section 3.6.2), the actual cap thickness may have been in the 22 to 24-cm range.

Examining the maximum extent of the cap, the no tidal current simulation matched the SPI measurement best, with the 1-cm MDFATE contour acting as the edge of the definable cap, at about 240 cm (SPI) and 220 cm (MDFATE) (Figure 4-11). The MDFATE simulation with tides overpredicted the maximum extent of the cap by over 200 m. In the upslope direction, both the MDFATE with no tidal currents and MDFATE with tidal currents overpredicted the maximum cap extent, 215 and 185 m, respectively, compared to the SPI measurement of maximum cap extent, 100 m.

SU5 Simulations. The SU5 simulations offered the best chance to compare the differences in placements between LU and SU because the number of placements was the same, the pattern of placements was the same, and the volumes were nearly identical, although SU had 10 percent more material placed. While the actual mounds as measured by SPI and cores were relatively similar with maximum thicknesses of 8 to 10 cm, the MDFATE simulations showed the differences due to water depth and slope. At Cell LU, MDFATE overpredicted mound thicknesses, while at Cell SU, MDFATE tended to underpredict mound thicknesses. For example in Cell LU, the simulation with LU average sediments, no tides, and stripping predicted a mound 18 cm thick, while the comparable mound in Cell SU was predicted to be 6 cm thick. Note that when sediment characteristics, more similar to those of SU (i.e., less dense) were used, the MDFATE simulation with no tides and stripping, predicted the maximum mound thickness to be 8 cm (Figure 4-12). Also, the predicted mounds in LU were generally more circular compared to those in SU, which tended to be stretched and displaced in the downslope direction (Figure 4-12).

SU21 Simulations. The SU21 simulations also reflected the influences of the deeper depths and different placement pattern compared to the LU25 placements. For example, the 25 LU placements covered an area 450 m long and 150 wide, while the SU placements covered an area 300 m long and 300 m wide. The effect of the greater depths in Cell SU resulted in a larger footprint for the SU

placements. The MDFATE and SPI cap thickness measurements showed the SU21 cap to be roughly 800 m long and 740 m wide, while the comparable LU25 placement, which covered a length 150 m longer, had a total length of 865 m, only 65 m longer than the SU21 placement. Similar effects of water depth can be seen in cap thickness: placements in Cell SU resulted in thinner caps than roughly comparable placements in Cell LU.

Initial SU21 simulations used the same sediment characteristics as those from the LU45 and LU71 placements. When better core data became available, a second round of simulations was made with slightly less dense sediments that produced slightly thicker mounds. Like the LU25 simulations, the SU21 simulations were best matched when no tidal currents were included along with inclusion of stripping of all sediment fractions (Figure 4-13).

4.3.5 MDFATE results – spreading placements in Cell LD

Single load. There was reasonable agreement on single load placements considering limitations in MDFATE modeling capabilities in spreading mode and the fact that true particle settling was not achieved. MDFATE predicted maximum mound thickness of 1 cm, while the SPI measurement showed a maximum of 2.5 to 3 cm (Figure 4-14). However, this is based on the apparent inclusion of a large volume of resuspended EA material in the SPI thickness measurement. In fact, the SPI estimated volume was 2,230 m³, compared to the volume in the vessel of 976 m³ (NATCO estimate – equivalent in-channel volume equal to settled solids hopper volume) and the MDFATE estimate of volume on the bottom of 835 m³. The EA depth of disturbance ranged from 0.8 to 2 cm. When the estimated volume of EA sediments included in the SPI cap thickness measurement is taken into account and the average thickness of the EA sediment layer is subtracted from the SPI measurement, agreement between SPI and MDFATE is good.

The rate for many of the LD placements was nonuniform, which reduced the accuracy of the prediction. Typically, almost 65 percent of the hopper load was released in the first one-third of Cell LU (the southeasternmost portion of the cell), with 17 percent released in each of the remaining third of the cell (Appendix J, Section 5.2.4). This nonuniform rate of release resulted in a dog bone shaped bottom footprint, which was wider at the ends and narrower in the center. The wider section at the end of the cell is likely due to release of a relatively large amount of material at the very end of the load. MDFATE is not able to model a nonuniform rate of release.

The MDFATE conventional placement simulation of LD1 did not match the SPI measured mound nearly as well as the spreading mode simulation. The conventional placement mound was too narrow, peaked, and greatly overpredicted the cap elevation. Therefore, conventional placement was not used for modeling multiple loads in Cell LD.

Multiple placements. The full nine placements simulation in Cell LD showed good agreement considering the limitations in MDFATE modeling capabilities in

spreading mode. The MDFATE simulation predicted a mound with a maximum thickness of 11 cm, while the SPI data indicated a similar thickness (Figure 4-15). The MDFATE predicted cap covered a somewhat smaller area than the SPI measured cap. This was likely due to the fact that while the MDFATE spreading simulations are based on particle settling with no currents, the bottom current measurements indicated that there was a definite bottom surge associated with the LD placements.

One of the difficulties in modeling placements in Cell LD was the apparent change in grain size. The baseline vibracoring effort in A-III borrow site showed the average D_{50} to be 0.33 mm. Samples collected from the hopper showed a D_{50} of about 0.22 mm. Cores collected postcap had a sand size D_{50} of about 0.17 mm. This seems counterintuitive, i.e., one would normally expect the dredging and placement process to winnow out the fines and make the material coarser. Possible explanations include insufficient sampling in the portion of the A-III borrow site dredged for cap material, or more likely mixing of EA sediments with the borrow site cap material during the coring process. This issue should be studied in more detail if borrow site material will be used on the full cap. Additional coring of the cap in Cell LD may also provide additional information.

4.4 STFATE Modeling for Plume and Surge Characteristics

4.4.1 STFATE applications

The objective of STFATE simulations prior to placement was to examine bottom impact velocities, horizontal surge velocities, and plume impacts on kelp beds from individual loads. After placement, STFATE simulations were conducted for single load events and results were compared to measured horizontal surge velocities, plume dimensions determined from acoustic backscatter data, and suspended sediment concentrations obtained from water samples. Input for simulations made after placement utilized field data collected during the capping operation. Several STFATE hindcast simulations were made while waiting for all of the field data to become available. This section describes the final STFATE simulations conducted to compare (a) computed bottom surge velocities with average bottom surge velocities calculated from bottom mounted current meter measurements, (b) computed plume size with dimensions determined from acoustic backscatter data, and (c) computed suspended sediment concentrations with measured concentrations determined from water samples collected in the bottom surge (McDowell et al. 2001; SAIC 2001).

4.4.2 STFATE input

The STFATE simulations used the same multibeam bathymetric survey data collected by the Los Angeles District as that used in the MDFATE simulations.

Values of the ambient currents used in model simulations prior to the capping operation were based on the same summarized results of a PV Shelf current study as part of NOAA investigations of the PV site (Noble 1994) used for the MDFATE simulations. After the capping operation, ambient currents were based on data from an ADCP, drogue paths, and bottom mounted current meters. The ambient velocity determined from these data was assumed to apply at the point of placement. This velocity was then “spread” over the STFATE numerical grid using an algorithm discussed in Appendix K. The ambient velocities specified at the point of placement for each of the seven simulations, i.e., LU1, LU2, LU3, LU4, LU5, SU1, and LD1, are given in Table 4-6.

The sediment used for STFATE simulations prior to actual placements was the Queen’s Gate fine sediment and the A-III borrow site sediment with 0.4 mm-diam described in the “MDFATE input” section. Sediment characteristics are defined in STFATE by the following parameters: specific gravity, volume fraction of each type, fall velocity, as-deposited void ratio, critical shear stress, cohesiveness, mixing, and stripping. These, along with volumes of placement material, are summarized in Table 4-7.

It should be noted that the volumes listed in Table 4-7 are those assumed to leave the placement vessel very quickly. As discussed in Appendix K, these were determined from an inspection of the plots of vessel draft versus time. It is assumed that the initial bottom surge detected at the bottom mounted current meters is primarily a function of the amount of material released very quickly.

4.4.3 STFATE bottom surge current prediction results

As previously noted, a major purpose of the STFATE simulations after the capping operation was to compare bottom surge velocities computed by STFATE with those determined from bottom-moored current meters. Due to the simplistic nature in which STFATE computes the spatially varying bottom surge, it was decided to compare the average velocity of the surge from the point of placement until it reached the bottom-moored current meters located at various distances from the placement point. See Appendix J for details on the actual measurements.

Data from the LU1 placement were used in a model validation effort, resulting in the selection of various model coefficients, e.g., the convective descent entrainment, bottom form drag, and bottom friction coefficients (see Appendix K). Simulations for LU2 through 5, SU1, and LD1 were then conducted with the same coefficients. A brief summary of model results from the LU1 placement simulation is presented before discussing the comparison of model results with the remainder of the field data.

The descent of the single placement cloud through the water column took 7.4 sec before the leading edge impacted the bottom at LU (Figure 4-16). From an initial radius of 9.3 m the placement cloud grew to a final radius at bottom impact of 24.4 m as a result of entraining ambient water. The insertion velocity of the placement cloud was 292 cm/sec, and cloud velocity increased due to

gravity to a maximum velocity of 384 cm/sec during the descent. However, because of the dilution of the cloud and resistive forces acting on the cloud, its velocity at bottom impact decreased to 222 cm/sec. As a result of the placement cloud's energy, the cloud begins to collapse vertically and spread horizontally over the seafloor. For the LU1 placement, the bottom spreading ended 740 sec after the placement operations began. The horizontal dimensions of the cloud at the end of spreading were computed to be 299 by 298 m (Figure 4-17). The SPI 1-cm contour dimensions for the LU1 placement were 245 m by 215 m.

The available field data were from current meters located about 100 m and 165 m downslope from the placement point. From the current meter measurements, the average speed of the bottom surge during the time it traveled to each meter (Figure 3-9) was determined. The LU1 field data indicated that the average surge speed from the moment it struck the bottom until the front moved past the first ARESS meter (about 100 m away) was 91 cm/sec; whereas, the average speed during its travel to the second meter (165 m away) was 68 cm/sec. The average speeds computed by STFATE were 81 cm/sec and 65 cm/sec, respectively. Results for all seven simulations are summarized in Table 4-8 and Figures 4-18 and 4-19. Computed values are presented at some locations even though field data were not available at those locations.

In Table 4-8, MBE is the Mean Basis Error and ARE is the Average Relative Error. Each is defined as follows:

$$MBE = \sum (M_i - O_i) / N ,$$

where

M_i = Model value

O_i = Observed value

N = Number of observations

and

$$ARE = \sum | M_i - O_i | / \sum O_i$$

The comparison of model bottom surge speed computations shows an excellent agreement with the field data for the LU1 placement. Of course it should be remembered that model coefficients were adjusted to provide this agreement. As discussed in Appendix K, the major parameters influencing the bottom speed computations were the descent entrainment and drag coefficients, the fraction of kinetic energy at impact lost due to bottom impact (S1), and the form drag and bottom friction coefficients in the bottom collapse phase. S1 has a significant impact on the initial speed of the surge since it controls how much of the kinetic energy at impact is available to drive the initial movement of the surge. However, the initial kinetic energy is dissipated fairly quickly and the longer-term movement of the surge is controlled by the conversion of potential energy to kinetic energy. The descent entrainment and drag coefficients impact the

potential energy of the cloud at bottom impact, as well as, its kinetic energy. Since the bottom collapse form drag and bottom friction coefficients control the dissipation of surge kinetic energy, they have more of an impact on the average surge speed over greater distances.

Table 4-8 and Figures 4-18 and 4-19 reveal that agreement between measured and computed average surge speeds is not as good for the LU2 simulation. As discussed in Appendix K, the reason isn't entirely known. However, there is uncertainty in the amount of placement material immediately released and the exact location of where the material was released since the placement vessel experienced more drift during this placement than during any of the other LU placements. Agreement between measured and computed surge speeds is quite good for all other simulations. It is difficult to make general statements concerning the comparisons shown in Table 4-8. For some simulations, at some distances, the computed values are higher than the measured speeds, but for others they are lower. Four of the simulations had a positive bias, whereas, the other three had a negative bias. Of course, the general trend of decreasing speed with distance from the placement point is observed in both the measured and computed surge speeds. In general, the rate of decrease seems to compare well, implying that the conversion of potential energy to kinetic energy and the dissipation of the kinetic energy are represented reasonably well in STFATE.

Simulations LU1 – LU5 were similar, with the major differences being the amount of material immediately released and the ambient currents. However, placements SU1 and LD1 were quite different from the LU placements. SU1 occurred in a much greater water depth. This is reflected in the lower surge speeds and the fact that the computed bottom collapse cloud spreads over a greater distance. The reduced surge speed and larger surge footprint at the deeper site agree with data collected by Bokuniewicz et al. (1978).

The LD1 placement was a spreading operation in which the material was slowly released over about 10 min along the length of the LD cell. Since the material was released at a slower rate than in the LU and SU placements, one would expect lower bottom surge speeds. Table 4-8 and Figure 4-19 show that this is indeed true for the measured, as well as, the computed surge. For example, at 60 m from the placement point, the measured speed was 34 cm/sec, whereas, the computed value was 38 cm/sec. Compare this with the computed LU5 surge speed at 60 m of 110 cm/sec.

4.4.4 STFATE TSS predictions

Water samples were collected in the field for the LU1, LU4, LU5, SU1, and LD1 operations for the purpose of determining TSS concentrations. Most of the samples were collected very near the bottom to capture surge TSS concentrations. Of course, there is no way to know how much of the sediment in the samples came from the placement versus material being eroded from the bottom due to the surge. STFATE does not compute and display suspended sediment concentrations until the bottom collapse phase has terminated. Thus, in

these simulations no information on concentrations is available for the first 10-15 min of the simulation. At the end of the collapse phase in the LU1 simulation (about 12 min), maximum TSS concentrations ranged from 50-100 mg/L in the upper water column to 250-500 mg/L in the lower water column. At the end of 5 min, one measured TSS concentration at about middepth was about 1,600 mg/L. This does imply that material is stripped away from the top of the bottom surge, as is computed in STFATE. After 35 min, LU1 field data indicated TSS concentrations close to 100 mg/L near the bottom, whereas, STFATE computed maximum values of 250-500 mg/L. There is no way to know whether the water sample collected represented the maximum concentration, so comparing these TSS values is difficult.

TSS concentrations from water samples collected during the LU4 operation were as high as 3,400 mg/L after 1 min, with those concentrations decreasing near the bottom to about 15 mg/L after about 30 min. After 15 min, STFATE computed maximum concentrations of 25-50 mg/L very near the bottom. TSS values collected near the bottom in the LU5 operation were about 2,700 mg/L after 1 min and decreased to less than 50 mg/L after 32 min. After 31 min, STFATE computed upper water column maximum concentrations of 10-25 mg/L and 100-250 mg/L in the lower water column. Again, it is difficult to directly compare the field data with the computed concentrations.

In the SU1 operation, water samples collected near the bottom (60-61 m) after 3 min revealed a TSS concentration of 27 mg/L, whereas, after 22 min at the same depth the concentration was 10 mg/L. This compares fairly well with computed maximum concentrations of less than 50 mg/L at a depth of 58 m after 34 min.

TSS concentrations measured for the LD1 operation were quite low, e.g., less than 20 mg/L, except for one sample collected 21 min after the placement began which gave a value of 350 mg/L at a depth of about 44 m. STFATE computed a maximum concentration after 25 min at a depth of 39 m of 250-500 mg/L.

4.4.5 STFATE far field plume predictions

Comparison of far field plume locations and dimensions were made between STFATE predictions and data collected by the BBADCP. Qualitatively, the agreements were reasonable, particularly for those placements that were almost stationary, e.g., the LU1 operation. However, for those operations where the vessel was turning while disposing material, e.g., LU4, there was less agreement in the comparison of the size of the computed plume and that inferred from the BBADCP data. Plots of the computed water column plume are displayed in Appendix K. The impact of the vertical shear in the ambient currents can clearly be seen.

When placement takes place from a stationary vessel, both the model and the data from the BBADCP transects clearly show a water column plume that increases in size with depth. For example, after about 30 min from the beginning of the LU1 placement, STFATE computed a water column plume with a width of

about 210 m in the upper water column and about 490 m in the lower water column. These widths were based on a cutoff concentration of 1 mg/L. Data from the BBADCP after 30 min showed an upper water column plume with a width of about 200 m and a lower water column plume of about 400 m. These results imply fairly good agreement between the size of the water column plumes computed and those measured. However, direct comparisons are difficult since the locations of the BBADCP transects relative to the centroid of the plume are unknown.

When placement takes place while the placement vessel is moving, especially while turning, water column plumes that appear to have a uniform width throughout the water depth can be generated. Results from the LU4 placement that imply this are presented in Appendix K.

4.5 D-CORMIX for Modeling Direct Pump-out

As noted earlier, the D-CORMIX model was run to determine if placing cap material by direct pump-out through the drag heads would result in a bottom impact at a greater velocity than would be expected from conventional bottom placement.

4.5.1 Input

D-CORMIX required input data of bottom slope, water depth, dredge characteristics, pump-out time, and dredge speed. The input data for the CD-CORMIX simulations are given in Table 4-9.

In May 2000, three CD-CORMIX simulations were run using 0.79 m^2 as the size of the material exit area on the drag head. The release depth for all of these simulations was 21 m. The initial impact velocities were estimated using the following water depths and slurry densities:

47-m water depth, slurry density = 1.2 g/cm^3

47-m water depth, slurry density = 1.3 g/cm^3

66-m water depth, slurry density = 1.2 g/cm^3

Following these simulations, however, a visual observation of the drag head on the dredge *Sugar Island* indicated that the material exit area on the drag head was about 2.3 m^2 , roughly three times larger than the value used for the initial CORMIX runs. Three additional simulations were run in June 2000 to determine if the size of the material exit area would affect the impact velocity values from the previous simulations. The slurry density was 1.2 g/cm^3 for all of the new simulations. In addition, slightly more conservative water and release depths were used to calculate the new estimates. The water and release depths are as follows:

- a. 40-m water depth released at 10 m.

- b. 65-m water depth released at 10 m
- c. 65-m water depth released at 21 m

4.5.2 Results

The initial CD-CORMIX estimates of bottom impact velocities ranged from 1.7 to 2.4 m/sec for 47-m and 1.2 m/sec at 66-m. Estimates for the second set of estimates were not significantly different, even at the more conservative fall distances. Comparison of the initial impact velocity estimates with the later estimates indicated a velocity decrease of the plunging plume (jet) at impact by less than 2 percent. This comparison showed that the plume velocity at impact is driven by density and not by the initial momentum. The average velocity was decreased by less than 7 percent, and angling the plume upward had no effect on the velocities. Because these impact velocities were less than or equal to the estimated impact velocities expected from conventional surface release, a decision to conduct a trial placement using direct pump-out was made.

No data were collected on actual bottom impact velocities from the single direct pump-out placement. Therefore there are no results to compare actual and predicted values.

4.6 Pilot Cap Study Implications for Full-Scale Cap Volume Predictions

A critical aspect of the pilot cap study was to verify the volumes required to produce a cap of a given thickness over a given area. Accurate estimates of required cap volume will also be critical for any full-scale cap. The as-placed void ratio is a key factor in determining the volume of cap material needed to achieve the design thickness for a capping project. Volume estimates for the pilot capping study were based on an earlier estimate of the as-placed void ratio developed as part of the Palermo et al. 1999 report. The actual as-placed void ratio for Queen's Gate sediment, computed based on cores from Cells LU and SU, was considerably lower than the 1999 estimate. As a result, the cap layers that were constructed in the pilot study were not as thick as initially expected.

The revised sediment volume relationships measured during the pilot study make it possible, along with other loss estimates and lessons learned during the study, to compute the volumes of sediments and the corresponding number of hopper loads that would be required for full-scale capping of the Palos Verdes Shelf. The remainder of this section describes the pilot capping study limitations associated with measurement and computation of the sediment volume relationships. This is followed by a discussion of the sediment volume relationships derived from the pilot study data.

4.6.1 Limitations on measurement of pilot cap study sediment volume relationships

One of the goals of the pilot study was to acquire data on the sediment volumes and losses associated with cap placement. This information that can be used to improve the estimates of volumes required, both in situ and in-hopper to produce a cap of given thickness for a full-scale project as were done in Palermo et al. 1999. The information on the volumes is also needed for computing cost estimates. While some improved information was acquired during the pilot study, difficulties in measuring cap thickness and extent with a high level of accuracy resulted in considerable amounts of uncertainty on volume and loss computations.

Achieving an accurate estimate of cap volume requires knowledge of the cap extent, thickness, and also bulk density (mass per unit volume). Knowledge of the cap bulk density is required because the volume occupied by a given mass of sediments will change as the void spaces between the sediment particles change. To accurately compute volumes and costs, the bulk density of the material in the channel prior to dredging, in the hopper after dredging, and on the bottom following placement all need to be known accurately. Also, any losses of material during dredging and placement have to be calculated. The detailed geotechnical testing and undisturbed sampling required to achieve accurate estimates of bulk density are not routine and were not done on the in-channel Queen Gate or A-III borrow site sediments prior to dredging. As part of the monitoring program associated with the pilot cap study, geotechnical testing of the material in the hopper and as-placed were conducted. However sampling problems, particularly coring artifacts in the as-placed cap material, resulted in considerable scatter in the data. See Chapter 3 for more details on coring problems. Also, detailed data on hopper tonnage and volume of sediment in the full hopper were no part of the initial monitoring plan.

A major difficulty in computing cap volumes was an accurate estimate of cap extent and thickness following placement. The water depths at the site combined with the thinness of the caps did not allow conventional surface bathymetry to serve as a useful tool for measuring cap thickness. Therefore, cap thickness measurements were based on SPI images and cores that were limited in number by costs. As described in Chapter 3 and the SAIC monitoring report, there were factors and problems that reduced the usefulness and accuracy of the cap thickness data. During placement, the upper 2 to 3 cm of EA sediments were resuspended and mixed with the cap sediments. These EA sediments were included in the estimated cap thickness as determined by SPI and cores, making it difficult to estimate the thickness contribution solely from the cap material placed. In some cases the thickness of EA sediments resuspended and mixed with cap sediments were reasonably accurately known, but in other cases only a conservative minimum could be determined. Also, only on the initial placements in LU, SU, and LD did the SPI camera penetrate fully through the cap. These initial placements resulted in only a few centimeters at most of cap material. When the resuspended EA sediments were included, the contribution of the EA sediments was about 25 percent of the total volume and at many locations was a significant portion of the total thickness. When five placements were monitored,

the percentage of the EA sediments in the cap decreased, but in the central portion of the mound the cap exceeded penetration of the SPI camera. This made the accurate determination of maximum cap thickness and volume computation impossible.

A critical component for computing volumes is the change in bulk density from the sediments in the channel to the bulk density in the hopper dredge to the bulk density as-placed on the PV Shelf. Based on information from NATCO, where the volume and mass of up to 20 hopper dredge loads were compared to before and after channel surveys, the in situ bulk density of Queen's Gate sediments was found to average about 1.9 g/cm^3 . Full hopper load values and the volume of solids settled in the hopper were available in two cases. For those cases, the overall bulk density of the material in the hopper was in the 1.5 to 1.6 g/cm^3 range, higher than the initially estimated bulk density of 1.4 g/cm^3 .

Even with the problems in determining sediment properties, the pilot capping project provided improved information that can be used to update volume estimates for full-scale capping using sediments similar to Queens Gate or those found in the A-III Borrow Site. Data from the March 2002 field study will likely provide some better sediment/volume relationship data that can be used to improve the full-scale capping volume computations.

4.6.2 Pilot study sediment volume relations

This section follows the logic developed in comparable sections of Appendix E from Palermo et al. (1999) for computing full-scale cap volumes required. However, updated information from the pilot capping study is provided. This information can be used for future estimates of full-scale cap volumes.

Queens Gate. Table 4-10 lists the values of the different variables used to describe the sediment solid/volume relationships for each of the phases in the dredging/placement process for sediments removed from the Queen's Gate Channel during the pilot cap study. For each row in the table, a measured value of bulk density or water content was used to compute the remaining values. The void ratio, porosity, and volume fraction concepts are discussed in detail in Appendix K. The void ratio of the in-source sediment (sediment in the Queen's Gate Channel prior to dredging) 0.91, was computed from information provided by NATCO based on a calculated in situ bulk density of 1.9 g/cm^3 . The second row is the in-hopper sediment volume relationship which is based on the detailed load and volume data collected from the initial placements in LU and SU. These numbers were averaged, which produced an average bulk density of the entire hopper load (settled sediments and slurry) of 1.54 g/cm^3 . For full-scale capping computations, the bulk density should be reduced to 1.5 g/cm^3 , based on the assumption that during routine capping the dredge efficiency would be somewhat less than achieved during the initial loads of the pilot cap study. Note that this value is still above the 1.4 g/cm^3 density predicted initially by the contractor.

However, this overall hopper bulk density concept is not generally reported by dredging contractors when estimating production. As described earlier in Chapter 4 and Appendix K, the dredging contractors typically report the hopper load as the equivalent volume of channel material removed at the in-channel or in-source bulk density. Based on experience during the pilot capping project, this relationship between hopper load and in-source volume removed was approximately 1:1, thus the values in this row are the same as the “In-source” row. Note that this volume also corresponded to the volume of settled solids in the hopper. These values will be used in further calculations.

The last row is the sediment volume relationships for Queen’s Gate material as-placed on the PV Shelf based on the cores collected as part of the monitoring program. An average of LU and SU core bulk density values (1.79 and 1.60 g/cm³ for LU and SU, respectively) was used to compute the values noted. The next to last column of Table 4-10 also shows the relative volume occupied by the solids in each of different phases of the dredging/placement process. Using these values, 1.0 m³ dredged from in-channel would occupy 1.0 m³ in the hopper during transport, and 1.14 m³ after initially settling on the bottom, not accounting for losses during the process. When losses are computed these values can be adjusted to account for losses.

A-III Borrow Site. Using similar logic, a table with the same sediment volume relations for the A-III Borrow Site was created (Table 4-11). The void ratio of the in-source sediment was assumed to be 0.91. This void ratio corresponds to an in situ bulk density of 1.90 g/cm³ and is based on the dredging contractors’ assumed in situ density, which was the same for Queen’s Gate. For a future capping project design, a good estimate of the in-source of void ratio and bulk density is needed.

The second row is the in-hopper sediment volume relationship which is based on information supplied by NATCO, which assumed an overall bulk density of the entire hopper load of 1.8.

Similar to the logic previously noted, the contractor reported hopper loads as volumes at the estimated in-source bulk density. Therefore this relationship between hopper load and in-source volume removed has a relative volume occupied factor of 1.0.

The last row of Table 4-11 is the of sediment volume relationships for Borrow Site A-III material as-placed on the PV shelf based on the cores collected as part of the monitoring program.

The cores collected after LD1 did not contain any obviously visible cap material. Thus, using the bulk density values from these cores did not make sense. Consequently, it was decided to use the MDFATE recommended value of an as-deposited void ratio of 0.75 for sand in the LD1 simulations. Developing as-placed void ratio values for the LD9 placements was difficult because there were no cores collected after the LD9 placements. The supplemental core data was not readily available when the LD9 simulations were initially being done; therefore an as-deposited value of 0.75 from LD1 was used (corresponds to a

bulk density of 1.98 g/cm³). In reviewing the supplemental core data for Cell LD, the bulk density value of the cap material in cores 105A and 108A (located at a depth of 8 to 12 cm) was 1.85 g/cm³. It was decided to use this value for the full cap volume computations. It is possible that a thicker cap might increase bulk density slightly; also placement in deeper water might reduce bulk density. Obviously, this issue will have to be revisited in the design of a full-scale cap.

4.7 Modeling Summary and Conclusions

This section summarizes applications and conclusions based on the numerical modeling conducted for the pilot study. It also briefly discusses the modeling work done in the in situ capping options study (Palermo et al. 1999) to fully summarize all the numerical modeling activities associated with this project. The potential for the models to be used for a full-scale cap design for the Palos Verdes Shelf is also discussed.

Numerical model simulations of various aspects of cap placement were conducted using the following ERDC-developed models in support of the pilot study: the MDFATE, STFATE, and D-CORMIX models.

4.7.1 MDFATE

MDFATE was the primary model used for the pilot study cap project. MDFATE model simulations were primarily used in the preliminary design phase (Palermo et al. 1999) to develop volumes required for various placement options, but also to bracket possible placement modes and sediments. For the pilot study cap project, MDFATE modeling was used to predict the area covered by both individual and multiple placements for a range of sediments and dredge operating characteristics to provide guidance for developing the Operations and Monitoring Plan. MDFATE predictions of cap thicknesses and area coverage were needed to make decisions on the spacing and location of the various monitoring activities, e.g., the spacing and extent of the SPI stations and cores. MDFATE was used in a predictive mode to define desired dredge operating characteristics (e.g., moving versus stationary) and to assist in computing individual spacing and placement patterns within a given cell that would result in the desired cap thickness. MDFATE was also used as part of a procedure to determine required cap volumes. During actual placement operations, MDFATE was used to determine placement spacings and to confirm the actual mound configurations were reasonably close to predictions, providing confidence to continue the project. The final set of MDFATE simulations were conducted in a hindcast mode using the best available measured data to determine how well the model could predict cap dimensions and thus determine its suitability for design of a full-scale cap.

The overall conclusion is that MDFATE did a reasonable job of predicting cap configuration for the Palos Verdes Pilot Cap and can be used for full-scale

cap design. As expected, placements in the shallower Cell LU, where the average measured depth is 43 m, resulted in a thicker cap and smaller mound than did comparable placements in Cell SU, where the average measured depth is 65 m. Exact correlation of modeling results with SPI measurements was difficult because in general the upper 2 to 3 cm of EA sediments were resuspended and mixed with the cap material. Coring problems made it difficult to verify the maximum cap thickness for the multiple placements where cap thickness often exceeds SPI penetration in the thicker portions of the cap. MDFATE's inability to include resuspension generally resulted in what appeared to be overprediction of maximum cap thickness over a small peak at the center of Cells LU for multiple placements. MDFATE predictions of maximum cap extent (based on the 1-cm contour) agreed well with the SPI estimates of maximum cap extent, particularly in the alongslope and downslope directions. The MDFATE spreading placements in Cell LD also had good overall correlations with monitoring data. Maximum cap thickness, about 11 cm, matched well with SPI measurements, though the MDFATE predicted mound was narrower than the SPI mound. This agreement was achieved in spite of the fact that true particle settling was not achieved during the LD placements.

Some impacts of slope and water depth were evident in the model results and were confirmed by monitoring data. The SU placements resulted in a slightly larger footprint and thinner mounds with some displacement downslope. Certain improvements to MDFATE, particularly in the spreading mode, would improve model application to a full-scale project. Various improvements in data collection would also improve model accuracy and reduce uncertainty. If additional monitoring data are collected that improve cap thickness or geotechnical properties, additional MDFATE simulations could be done.

The as-deposited void ratio used for the predictive and initial operational MDFATE predictions and cap volume requirements was based on a single data point from a disturbed sample. The as-deposited void ratio of 1.39 from this sample was much higher than values computed from the core samples of as-deposited cap material. Data from cores collected after cap placement showed the as-deposited void ratio ranged from 1.04 to 1.27, i.e., the actual void ratio was considerably smaller than originally predicted. This resulted in placing insufficient volume to achieve the design cap thickness goals.

The results from the monitoring and modeling data were used to update the estimates for full-scale capping projects. Preliminary indications are that the volumes and number of hopper loads for full-scale capping are less than those recommended in the earlier in situ capping study (Palermo et al. 1999).

4.7.2 STFATE

The STFATE model was used to predict the fate of the suspended sediment plume that remained in the water column, the impact velocity of the descending jet, and the bottom surge velocity. In addition, because of concern that the plume might adversely impact the inshore kelp beds, an STFATE simulation was conducted early in the pilot study cap study to predict the path and TSS

concentrations in the water column from a single placement of Queen's Gate cap material. The TSS data were used to make a qualitative, conservative estimate of potential impact to the kelp beds.

Except for the LU2 operation, the average bottom surge speeds computed by STFATE compared quite well with those determined from data provided by the bottom mounted current meters. The differences between the computed and measured values were generally within 10-20 percent. Given the simplistic nature in which STFATE computes a collapsing bottom cloud of dredged material over variable bathymetry, this agreement is remarkable. The agreement was about the same for the LU, SU, and LD operations, even though the water depth and mode of placement differed considerably between the LU, SU, and LD operations. All of the LU placements and the SU placement were intended to be stationary, whereas the LD placement was a spreading operation. The water depth for the LU and LD placements were about the same, whereas the water depths for the SU placement were much greater, i.e., in excess of 60 m versus 40 m for the other placements.

Computed impact velocities for the LU placements were all in the range of 210 – 240 cm/sec, whereas those for the SU1 and LD1 placements were 145 and 75 cm/sec, respectively. The lower value for the SU1 placement is reflective of the increased water depth and that for the LD1 placement reflects the fact that the placement was a spreading operation. No field data on bottom impact velocities were available.

Water samples were collected for the LU1, LU4, LU5, SU1, and LD1 operations to yield TSS concentrations. Most were collected very near the bottom. Measured values within 1-3 min after the placement were in the 2,000-3,000 mg/L range. No comparison could be made with STFATE results since TSS concentrations aren't computed until after the end of the bottom collapse phase. In all the simulations, the bottom collapse phase lasted for 10-15 min. However, there were a few measurements collected at 20-35 min after the placement that were "close" to those computed. For example, after 35 min a value of 100 mg/L was measured near the bottom, whereas STFATE computed maximum near bottom concentrations of 250-500 mg/L.

Only a qualitative comparison of the water column suspended sediment plume compute by STFATE could be made with the BBADCP data. However, for those placements that were essentially stationary, the agreement was good. After 30 min or so, widths of both the computed and observed plumes in the upper part of the water column were about 200 m, with lower water column plume widths of 400-500 m. For those simulations where vertical shear in the ambient currents was evident, both the computed and observed plumes demonstrated similar behavior. For example, the upper water column plume might move in one direction from the placement point, with the lower water column plume moving in a different direction.

4.7.3 Cap loss predictions

One of the primary goals of this pilot study was to estimate the percentage of cap material lost during placement, i.e., cap material that remained in the water column following placement and was transported beyond the monitored area by currents before depositing and that did not contribute to the cap. While simple in theory, comparing the mass of cap material in the hopper with the mass of cap material on the bottom after placement to compute mass loss is quite difficult in practice, and was made even more difficult by the thinness of the cap placed. Typically, the volumes in the hopper and on the bottom are compared, but because the bulk density (mass/unit volume) of the material in the hopper can change during placement, the change in bulk density in the hopper and as-placed has to be taken into account. Section 4.6.1 discussed the limitations in computing the mass/volume relationships in detail, which include lack of good data of the in situ material prior to dredging, limited mass/volume relationships from the dredge, the inability of the SPI to fully penetrate the cap on all placements except the initial placement (to give an accurate measure of cap thickness), the inclusion of the EA sediment mixed into the cap (which increases the uncertainty of the cap thickness measurement), and the coring artifacts which prevented accurate measurements of core thickness and caused the variability in the bulk density data. Thus, our opinion is that the hopper volumes versus MDFATE volumes versus SPI and core volume have too much uncertainty to make meaningful comparisons. However, other data described in the following paragraphs make it possible to make some estimated of cap loss. However, forthcoming data from the March 2002 survey may allow for some meaningful comparisons.

The cap loss prediction should be based on a combination of data, including results from MDFATE simulations, STFATE simulations, and comparisons of mass of material in the hopper with that found after placement. MDFATE predictions of cap material lost (Section 4.3.4 and Table 4-5), i.e., material that either did not settle in the grid or was eroded and transported out of the grid during the long-term simulation, ranged from almost none (1 percent) during the spreading placement of A-III sediments, to 44 percent for the SU 21 placement with tidal currents and stripping. For the MDFATE simulation of the LU placements, the single placements resulted in a 10 percent loss of material. The multiple placement material losses ranged from 3 percent (no tidal currents and no stripping for LU5), to 29 percent (tidal currents and stripping for LU45). For the MDFATE simulation of SU placements, the single placement (no tidal currents and stripping) resulted in loss of 31 percent of placed material, while the multiple placement losses ranged from 13 percent (SU5 with no tidal currents and no stripping) to 44 percent (SU21 with tidal currents and stripping). It is suspected that the higher losses would not actually occur, that the MDFATE simulations for the deeper site (and perhaps the shallower site) do not run for a sufficiently long time to allow all the material that would actually settle in the actual placement to settle in the simulation. Also, the simulated grid was a bit small; increasing the grid size probably would have allowed additional material to settle inside the grid. Last, there are some questions on the accuracy of the critical shear stress values and whether any material is being eroded during the long-term simulations.

The STFATE information provides estimates of cap material loss, defined as percentage of material still in the water column when the simulation ended. As noted in Appendix K, the STFATE estimated percent solids in the water column after 30 min for the conventional placements ranged from a high of 15 percent (LU1) to a low of 5 percent (LU 4), with an average of 9 percent, with the single SU placement percent loss of 10 percent. For the single LD placement of A-III sediments, the STFATE estimated losses were 3 percent.

Mass losses to the water column from hopper dredge placements have previously been estimated at two to five percent (e.g. Truitt 1986).

It may be possible to provide additional confidence in the STFATE water column loss estimates by using the water sample TSS data from the pilot study. This data, combined with the STFATE and ADCP estimates of plume dimensions, could be used to provide an additional estimate of water column losses. Note, however, that there is a considerable amount of uncertainty due to the relatively small number of water samples collected.

From the preceding data, the following recommendations for cap loss data for full-scale capping are provided. For placement of Queen's Gate like sediments, a conservative estimate of 20 percent losses should be assumed, based primarily on the STFATE predictions. A less conservative estimate of losses would be in the 10 to 15 percent range. For spreading placements of A-III like sediments, a conservative estimate of 10 percent losses should be assumed, with a less conservative estimate of 5 percent losses.

4.7.4 D-CORMIX

D-CORMIX was used to estimate the bottom impact velocity of the cap material during the direct pump-out from the drag head. The model results showed impact velocities that were less than the impact velocities from conventional placement. During the single direct pump placement no measurements of bottom velocities were conducted. Thus, no further conclusions about the accuracy of CORMIX can be made.

4.8 Modeling Recommendations

This section provides recommendations for numerical modeling and related analysis associated with the pilot study and full-scale capping. The first three recommendations concern modeling associated with the pilot study. The next set of recommendations describes numerical modeling and data collection for a full-scale capping effort.

4.8.1 Additional MDFATE modeling

A relatively large number of MDFATE simulations were made for this project. However, lack of reliable measurements of cap thickness for the

multiple placements due to coring problems makes the MDFATE results somewhat in question. If additional monitoring of the pilot cap is done and good quality cores produce better estimates of cap thickness, then some additional MDFATE model runs to improve the predictions should be considered. Some additional model sensitivity simulations could also be done at the time to look at other issues in more detail such as the influence of vessel volume on cap geometry and the influence of sediment bulk density and as-deposited void ratio.

Both MDFATE and STFATE were developed as screening level models primarily for planning studies. Application of MDFATE in particular as a design tool for the pilot study has pointed out many model limitations and features that need to be added or improved for use as a management tool. Recommendations are included for the MDFATE and STFATE models and data collection efforts that would improve the full capping applications.

4.8.2 MDFATE model improvements

While the MDFATE model provided useful information for the preliminary design and pilot study, improvements should make it more useful for future capping projects on the PV Shelf. The suggested improvements are broken down into two categories; major improvements that will require a considerable effort (e.g., at least several months and a budget exceeding \$100,000) and would likely be funded through USACE research efforts and minor improvements, that would require days to weeks to complete and could be considered for funding by the project (e.g., \$10,000 to \$20,000).

Major improvements to MDFATE are centered on water current simulations and sediment transport algorithms. A needed improvement is the ability to allow time varying residual currents in addition to tidal currents. This improvement, combined with improvements to the sediment transport algorithms and critical shear stress specifications, should improve the simulation of the cap geometry. The sediment transport algorithm improvement is probably the most needed for future PV capping project and is probably not too difficult or expensive. In addition, algorithms to model resuspension could be added to MDFATE. However, because most caps are 50 to 100 cm thick, this is a feature that is probably not needed for the vast majority of capping projects. A quick, rather crude resuspension algorithm could be added. However, it would need some research for refinement.

In STFATE, the user can specify the values of the various coefficients that control the convective descent and dynamic collapse phases. As noted in the STFATE sections, some adjustment of these variables was required to produce estimates of bottom surge currents that best matched the measured data. At present, the user has no control over these variables in MDFATE; default values are used and are not readily determined. It would be straightforward to determine these values and compare them to the values that produced the best STFATE match to measured currents. If the variables are significantly different, then another minor improvement to MDFATE would be to allow the user to specify

the values of the various coefficients that control the convective descent and dynamic collapse phases as is presently allowed in STFATE.

MDFATE limitations on the ability to model the spreading mode, both in a hindcast and forecast mode, should be easily corrected. The major improvement needed would be to allow the vessel to have a heading of any orientation, instead of the north/south, east/west headings now allowed. In addition, the starting point for the heading should be specified, not the midpoint of the placement. Finally, capability to model a series of spreading mode placements in a single simulation, as is now the case for the conventional placements, should be included.

However, it should be noted that the hydrodynamic and placement conditions required to achieve particle settling are based on limited research and have extremely limited field verification. In fact, the LD placement modeled was the first true field verification of the spreading mode. Ultimately, additional research on the conditions that reduce vertical momentum and contribute to particle settling should be conducted.

4.8.3 STFATE model improvements

The STFATE applications to the Palos Verdes pilot project were minor compared to the MDFATE applications. If far field suspended solids are a major concern (e.g., at the kelp beds), two likely approaches to simulate multiple placements are recommended. The first would be to use a beta version of STFATE developed for a project on the Providence River, RI (Gailani et al. 2001),¹ that allows simulation of multiple placements and allows the input of time varying currents. However, the STFATE modifications made for the PV simulations that allow for vertical shear in the ambient currents and modifications that spread point velocity data over the numerical grid in a more reasonable fashion should be incorporated. One approach might be to take near field results from STFATE and then apply the Suspended Sediment Fate of dredged material model (SSFATE) (Johnson et al. 2000), which allows modeling over a longer time scale, larger area, and can handle 3-D currents. This would be a considerably more complicated application, although with good current data it should not be an overwhelming task.

If surge speeds continue to be an issue, then one option is to wait for the three-dimensional dredged material placement model being developed under DOER (Johnson 2001). This model will likely not be available until October 2003 at the earliest. Another option would be to use a beta version of an improved SURGE model developed for the Providence River Project (Gailani

¹ Gailani, J.Z., Smith, S.J., Scheffner, N.W., and Vanadit-Ellis, W. (2001). "Dredged material fate modeling of proposed Providence River confined aquatic placement (CAD) cells and ocean dredged material placement site (ODMDS), Report prepared for USACE New England District (draft) by U.S. Army Engineer Research and Development Center, Vicksburg, MS.

et al. 2001) to make improved predictions, after validation with bottom surge current data collected as part of the pilot study.

4.8.4 Data collection

Several aspects of data collection could be improved that would improve modeling and, hence, design and management of a full-scale capping project.

Sediment data. There is some concern that the samples collected from the surface of the hopper load do not adequately represent the majority of the sediments in the hopper. Collecting samples at multiple times during the hopper loading should provide a better estimate of the material in the hopper than a single sample at the end of the loading. Safety would be an issue that would need to be considered.

Grain-size distribution analyses should be performed at a minimum of one-half phi intervals or, even better, one-quarter phi intervals, rather than the one-phi intervals conducted for the past project. It was difficult to determine the D_{50} accurately with the relatively large range between sieve sizes for the GSD analysis done for the pilot project. In addition, the analyzed data should be provided in conventional percent finer versus grain size (log scale) plots. This would make it easier to determine the mean grain size.

Coring artifacts made it difficult to accurately determine as-deposited geotechnical properties; therefore, improved coring techniques are needed. Sampling over intervals of 4 cm appeared to composite cap and EA sediments near the interface. This made interpretation of properties (water content and bulk density) difficult. In the future, if cap material is evident in a 4-cm interval, the sample should be collected from the cap material, not the whole interval. For example, in the supplemental coring data for LD, geotechnical samples that contained pure (as could best be determined visually) cap material “golden sand” should be clearly identified and the samples for geotechnical testing collected.

Hopper dredge data. If practical, the dredge crew should enter loaded and light draft (corrected), vessel load (tons), total hopper volume, and settled volume into an electronic vessel tracking system to allow computation of bin density and related items. Alternatively, these values should be recorded in a separate spreadsheet. These data will assist in determining vessel loads and drafts for hindcasting MDFATE simulations of cap creation. Also, if a gyro compass vessel heading cannot be automatically added to the vessel tracking system, the vessel heading during placement should be manually entered into the system.

4.9 Full-Scale Cap Volume Computation Recommendations

The pilot study provided data that can be used to update volume computations for the full-scale capping project. If additional MDFATE

simulations are conducted based on additional data collected from the pilot project, then the results should be evaluated to determine if the MDFATE generated input for full-scale capping volumes should also be adjusted and new estimates created. Acquiring good estimates of in situ bulk density and void ratio for the source material are critical for accurate model simulations used to make volume computations.

**Table 4-1
Matrix of Predictive MDFATE Simulations Using Conventional
Placement with Queens Gate Sediments**

Water depths	43, 62 m
Dredge velocity range	Stationary, 0.5, 1.0, 2.0 knots
Placement duration	180 sec
Residual current	0, 5, 10 cm/sec
Sediment characteristics	fine, average, coarse

**Table 4-2
Summary of MDFATE Input**

Parameter	Cells LU and SU			Cell LD	
	Predictive	Operational	Hindcast	Predictive	Hindcast
Bathymetry	SPL multi-beam, 30-m grid	SPL multibeam, 30-m grid	SPL multibeam, 15-m grid	SPL multibeam, 30-m grid	SPL multibeam, 15-m grid
Sediment source	Queens Gate	Queens Gate	Queens Gate	A-III	A-III
Sediment characteristics	See Table 4-3		See Table 4-4	Appendix K	See Table 4-4
Dredge characteristics					
Draft loaded	6.0 m	6.0 m and ADISS/NATCO	ADISS/NATCO	6.0 m	ADISS/NATCO
Draft light	3.0 m	3.0 m and ADISS/NATCO	ADISS/NATCO	6.0 m	ADISS/NATCO
Duration	3 min	3 min/ADISS	ADISS avg. 3.5 to 4.5 min	30 min	ADISS avg. 7.5 min
Vessel speed	0-3 knots	0.1 knots	ADISS 0.3 –0.4 knots avg.	1.5 knots	ADISS 2 knots avg.
Load volume/bin density	Initially 1,200 m ³ /1.4, May 2,735 m ³ /1.4	2,735 m ³ /1.4 ADISS, NATCO	ADISS/NATCO ~ 1,000 m ³ /1.9	1,987 m ³ /1.86	ADISS/NATCO ~1,200 m ³ /1.8
Currents	vary	vary	ADCIRC tidal or no currents	vary	ADCIRC tidal or no currents
Waves	none	none	none	none	none

**Table 4-3
Queen's Gate Sediment Characteristics for MDFATE Predictive and Initial Operational Simulations of Pilot Cap Placements**

Sediment Type	% Sand	Sand Grain Size (mm)	% Silt	Silt Grain Size (mm)	% Clay	Clay Grain Size (mm)
Coarse	80	0.17	16	0.03	4	0.003
Average	63	0.12	30	0.03	7	0.003
Fine	56	0.09	35	0.03	9	0.003

Assumed particle specific gravity 2.70

**Table 4-4
Summary of Sediment Characteristics in MDFATE Hindcast Simulations**

Scenario/Sediment Types	Specific Gravity (g/cm ³)	Volume Fraction	Particle Size D ₅₀ (mm)	As-Deposited Void Ratio
Scenario	LU 1 – Based on full hopper volume			
Sand	2.7	0.27	0.09	0.75
Silt	2.7	0.065	0.05	2
Clay	2.7	0.0103	0.003	4.5
		Total 0.34		Composite 1.10
Scenario	LU5, LU 25, LU45, LU71, SU 5 and SU 21 with average LU sediments			
Sand	2.72	0.4078	0.09	0.75
Silt	2.72	0.0878	0.05	1.75
Clay	2.72	0.0206	0.003	4
		Total 0.52		Composite 1.04
Scenario	SU1, SU 5, SU 21 – SU sediments with bulk density of 1.50			
Sand	2.72	0.40	0.09	0.85
Silt	2.72	0.06	0.05	2.70
Clay	2.72	0.01	0.003	4.00
Clumps	1.40	0.05	5.00	2.00
		Total 0.52		Composite 1.27
Scenario	LD1 initial			
Sand	2.68	0.50	0.25	0.75
Scenario	LD1 later, LD full placements			
Sand	2.68	0.47	0.22	0.75

Table 4-5 Hindcast Simulations Summary					
Cell No. Placements, Sediment Characteristics	Scenario Simulated	1-cm Contour Dimensions l x w (m)	Maximum Simulated Cap Thickness (cm)	Maximum SPI Cap Thickness (cm)	Percent of Volume Retained
LU 1, LU1 Sed	Full hopper volume	250 x 205	2.9	5	89%
LU1, LU Avg Sed	In channel volumes	170 x 115	4.0	5	90%
LU 5, LU Sed	No tides, stripping	380 x 330	18	min 8-10	84%
LU 5, LU Sed	Tides, stripping	450 x 240	13	min 8-10	84%
LU 5, LU Sed	No tides no stripping	340 x 275	32	min 8-10	97%
LU 5, LU Sed	Tides, no stripping	425 x 265	25	min 8-10	97 %
LU 25, LU Sed	No tides, stripping	865 x 640	28	>15 cores	85%
LU 25, LU Sed	Tides, stripping	1,200 x 560	17	>15 cores	80%
LU 45, LU Sed	Tides, stripping	1,520 x 655	19	>15 cores	71%
LU 45, LU Sed	No tides, stripping	1065 x 700	30	>15 cores	86%
LU 71, LU Sed	Tides, stripping	>1,500 x 750	31	22-24 est cores	76%
LU 71, LU Sed	No tides, stripping	1,075 x 760	42	22-24 est cores	84%
SU 1, SU Sed inc void ratio	No tides, stripping	285 x 245	2.4	6	69%
SU 5, LU Sed	No tides, stripping	525 x 400	7	min 8-10	85%
SU 5, LU Sed	Tides, stripping	450 x 295	6	min 8-10	72%
SU 5, SU Sed	No tides, stripping	515 x 395	8	min 8-10	77%
SU 5, SU Sed	No tides, no stripping	490 x 350	13	min 8-10	87%
SU 21, LU Sed	Tides, stripping	910 x 535	10	> 15	62%
SU 21, LU Sed	No tides, stripping	770 x 725	16	>15	85%
SU 21, SU Sed	No tides, no stripping	715 x 563	26	>15	87%
SU 21, SU Sed	Tides, stripping	885 x 530	11	>15	56%
SU 21, SU Sed	No tides, stripping	780 x 740	17	>15	79%

**Table 4-6
Ambient Velocity Employed for Each Simulation**

Simulation	Depth (m)	Magnitude (cm/s)	Direction (Deg T)
LU1	15	21	310
	30	18	300
	40	15	280
LU2	15	10	60
	30	8	200
	40	8	240
LU3	15	6	150
	30	4	80
	40	4	80
LU4	15	14	300
	30	14	300
	40	14	300
LU5	15	15	60
	30	12	275
	40	5	275
SU1	15	16	125
	40	6	65
	60	5	160
LD1	15	20	300
	30	15	285
	40	9	285

**Table 4-7
Placement Volumes and Material Properties Used in STFATE Simulations**

Simulation	Volume (yd ³)	Sediment	Volume Fraction (%)	Fall Velocity (fps)	Void Ratio	$\tau_{critical}$ (lb _f /ft ²)	Cohesive	Stripped
LU1	2219	Sand	0.2688	0.020	0.75	0.015	No	No
		Silt	0.0655	0.006	2.00	0.009	No	Yes
		Clay	0.0103		4.50	0.002	Yes	Yes
LU2	1584	Sand	0.3690	0.020	0.75	0.015	No	No
		Silt	0.0369	0.006	2.00	0.009	No	Yes
		Clay	0.0041		4.50	0.002	Yes	Yes
LU3	1606	Sand	0.3403	0.020	0.75	0.015	No	No
		Silt	0.0656	0.006	2.00	0.009	No	Yes
		Clay	0.0041		4.50	0.002	Yes	Yes
LU4	1873	Sand	0.3690	0.020	0.75	0.015	No	No
		Silt	0.0328	0.006	2.00	0.009	No	Yes
		Clay	0.0082		4.50	0.002	Yes	Yes
LU5	2140	Sand	0.3657	0.020	0.75	0.015	No	No
		Silt	0.0369	0.006	2.00	0.009	No	Yes
		Clay	0.0164		4.50	0.002	Yes	Yes
SU1	2660	Sand	0.2490	0.020	0.75	0.015	No	No
		Silt	0.0249	0.006	2.00	0.009	No	Yes
		Clay	0.0028		4.50	0.002	Yes	Yes
LD1	6211	Sand	0.3894	0.025	0.75	0.015	No	No
		Silt	0.0184	0.006	2.00	0.009	No	Yes
		Clay	0.0020		4.50	0.002	Yes	Yes

Table 4-8 Comparison of STFATE Average Surge Speed with Field Measurements					
Simulation	Distance (m)	Measured (cm/sec)	STFATE (cm/sec)	MBE (cm/sec)	ARE (%)
LU1	100	91	81	-6.5	8.8
	165	68	65		
			53		
			43		
LU2	70	58	86	20.7	31.9
	150	42	62		
	250	32	46		
			37		
LU3	80	64	69	-2.0	11.3
	160	52	45		
	240	32	28		
LU4	70	93	94	6.7	9.4
	135	59	69		
	240	41	50		
	317		40		
LU5	60		110	4.0	5.8
	140	65	69		
	240		49		
	318		36		
SU1	115	55	64	8.0	13.1
	170	51	58		
	250		51		
	432		32		
LD1	60	34	38	-1.0	15.4
	140	33	27		
	170		24		
	240	31			

Table 4-9 CD-CORMIX Input Values	
Input Categories	Input Values
Bottom slope/location	2 deg, 1,500 m offshore
Water depths	40 to 66 m
Sediment characteristics	average
Dredge speed	1.5 knots
Pump-out time	40 min
Slurry density	1.2 and 1.3 g/L
Release depths	10 and 21 m
Sugar Island dredge dimensions	
Pipeline diameter	27 in.
Velocity	20 fps
Net drag head area	8.5 and 25 sq ft

Table 4-10 Sediment Volume Relationships for Queens Gate Materials				
Location	Void Ratio (e)	Porosity (n)	Solids Volume Fraction (V_f)	Relative Volume Occupied (no losses)
In-source	0.91	48 %	0.52	1.0
In-hopper	2.53	71%	0.28	1.87
In hopper – contractor method	0.91	48%	0.52	1.0
In-cap	1.15	53%	0.47	1.14

Table 4-11 Sediment Volume Relationships for Borrow Site A-III Materials				
Location	Void Ratio (e)	Porosity (n)	Solids Volume Fraction (V_f)	Relative Volume Occupied (no losses)
In-source	0.91	48 %	0.52	1.0
In-hopper	1.14	53%	0.47	1.22
In hopper – contractor method	0.91	48%	0.52	1.0
In-cap	1.0	50%	0.50	1.04

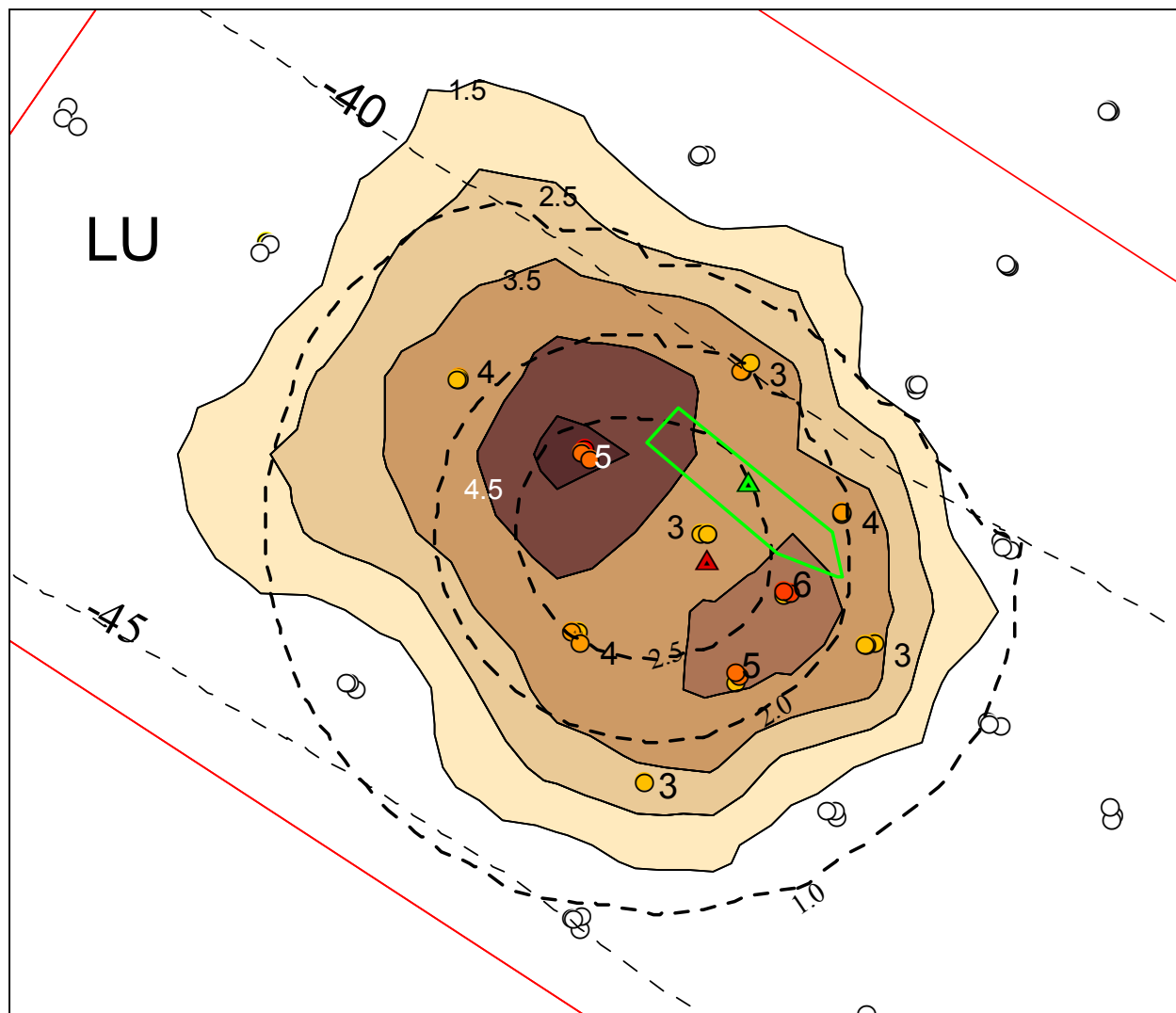

Figure 4-1. MDFATE hindcast simulation and SPI inferred cap thickness (centimeters) of initial LU placement. Dashed lines are MDFATE cap thickness contours (labeled with decimal, e.g., 1.0), solid lines are SPI cap thickness contours (labeled as decimal), colored dots show SPI station locations, labels next to colored dots are SPI cap thickness (integer), depth contours are in meters. Green line is dredge location at start of dump, green triangle is center of bin at start, red triangle is center of bin at completion of placement

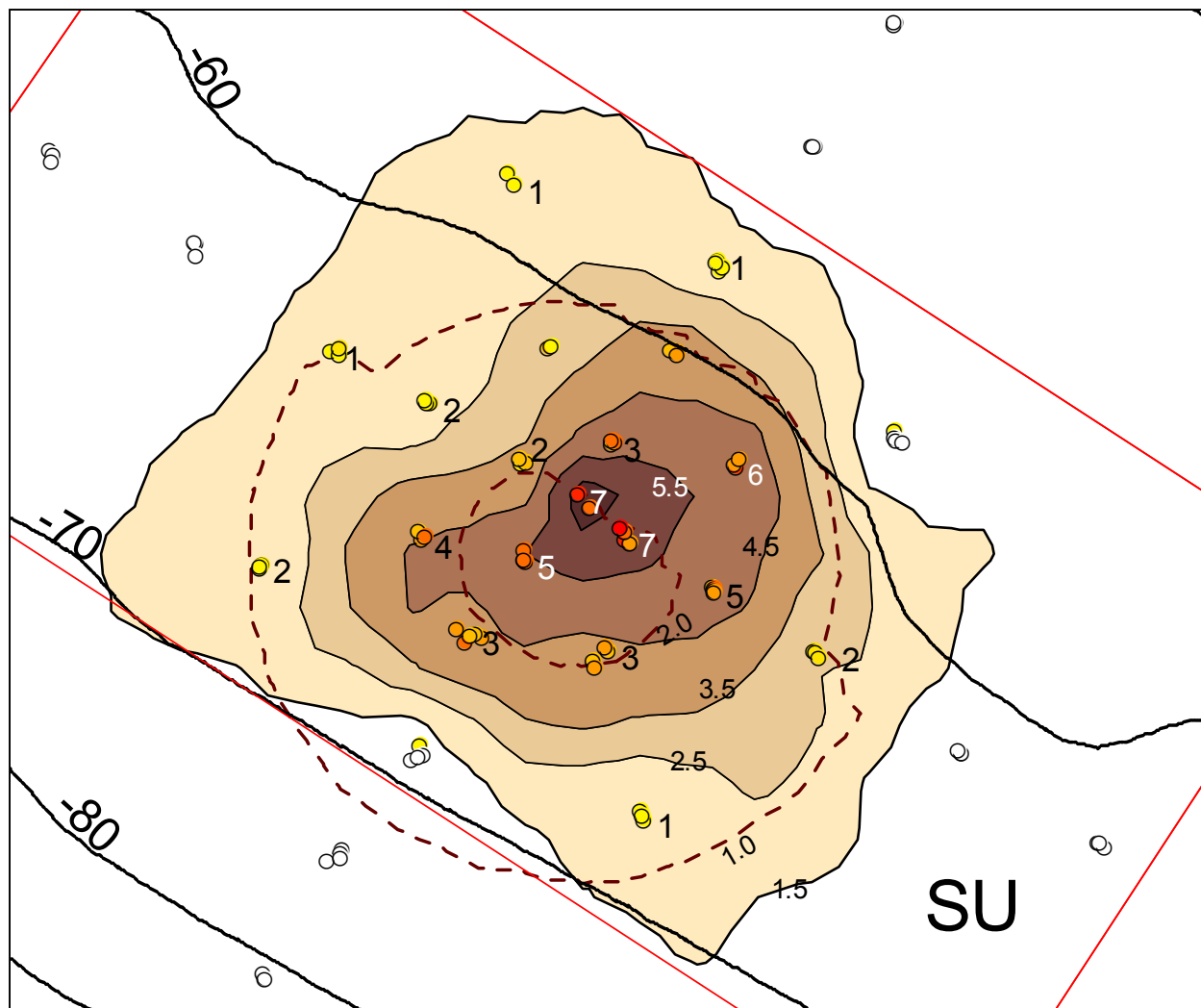

Figure 4-2. MDFATE hindcast simulation and SPI inferred cap thickness (centimeters) of initial SU placement. Dashed lines are MDFATE cap thickness contours (labeled with decimal, e.g., 1.0), solid lines are SPI cap thickness contours (labeled as decimal), colored dots show SPI station locations, labels next to colored dots are SPI cap thickness (integer), depth contours are in meters

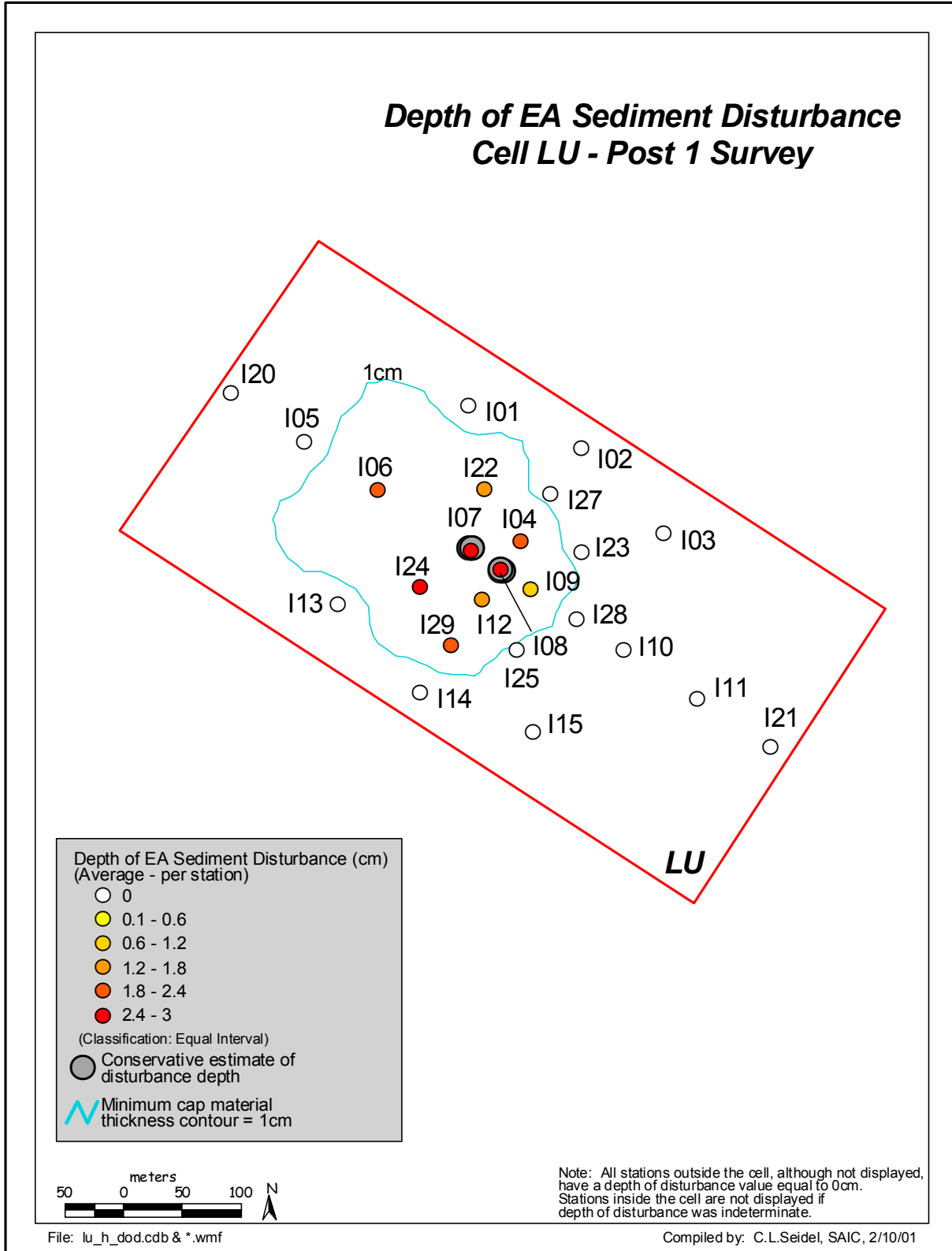

Figure 4-3. LU1 placement EA layer depth of disturbance based on SPI measurements (SAIC monitoring report)

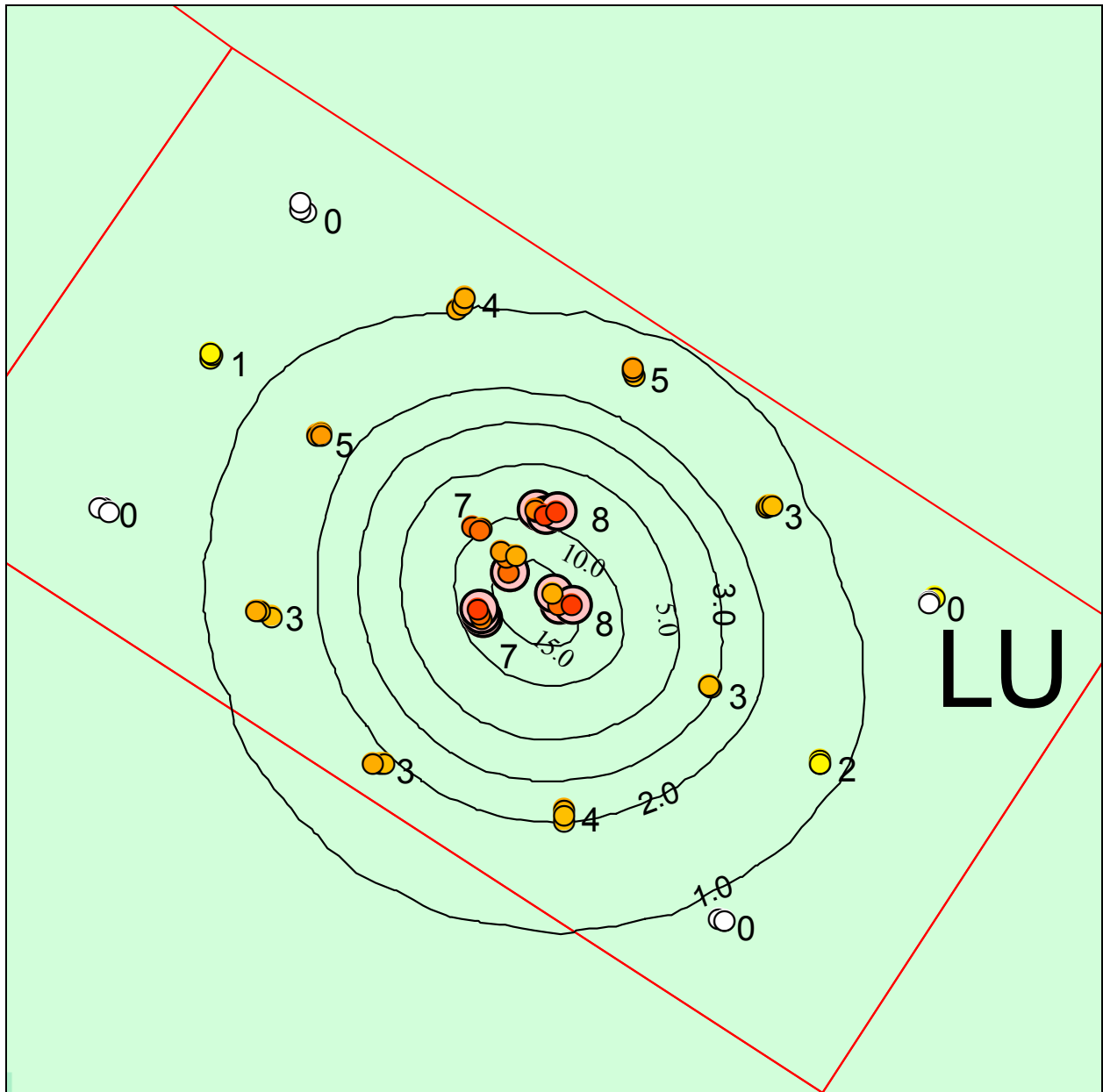

Figure 4-4. MDFATE hindcast simulation of LU5 and SPI inferred cap thickness (centimeters). MDFATE simulation had no tidal currents and included stripping of sediments. Solid lines are MDFATE cap thickness contours (x.0) in centimeters, colored dots indicate SPI stations, SPI thicknesses are in centimeters (whole numbers), pink dots are locations where cap thickness exceeded SPI penetration depth

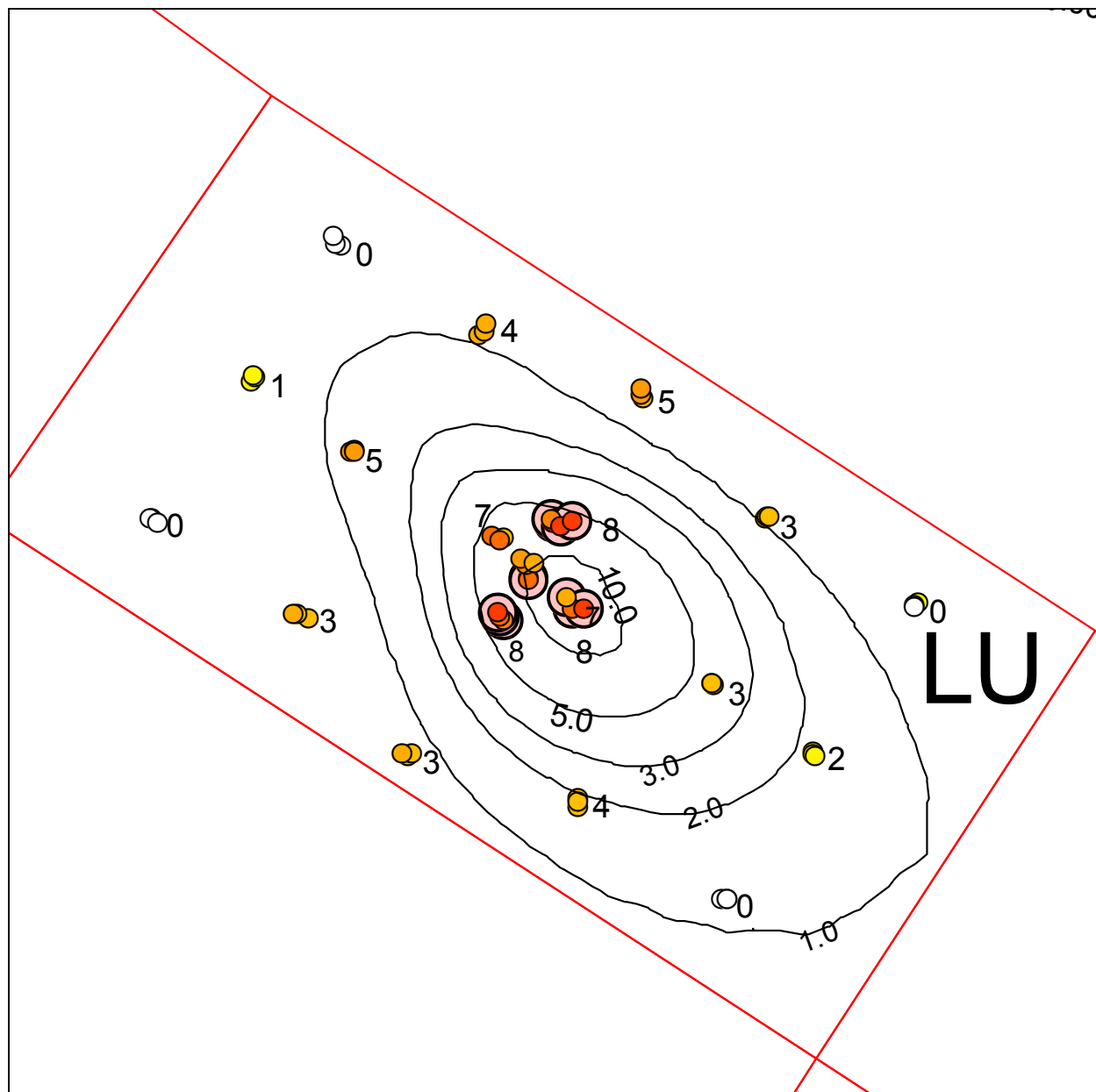

Figure 4-5. MDFATE hindcast simulation of LU5 and SPI inferred cap thickness (centimeters). MDFATE simulation had tidal currents and included stripping of sediments. Solid lines are MDFATE cap thickness contours (x.0) in centimeters, colored dots indicate SPI stations, SPI thicknesses are in centimeters (whole numbers), pink dots are locations where cap thickness exceeded SPI penetration depth

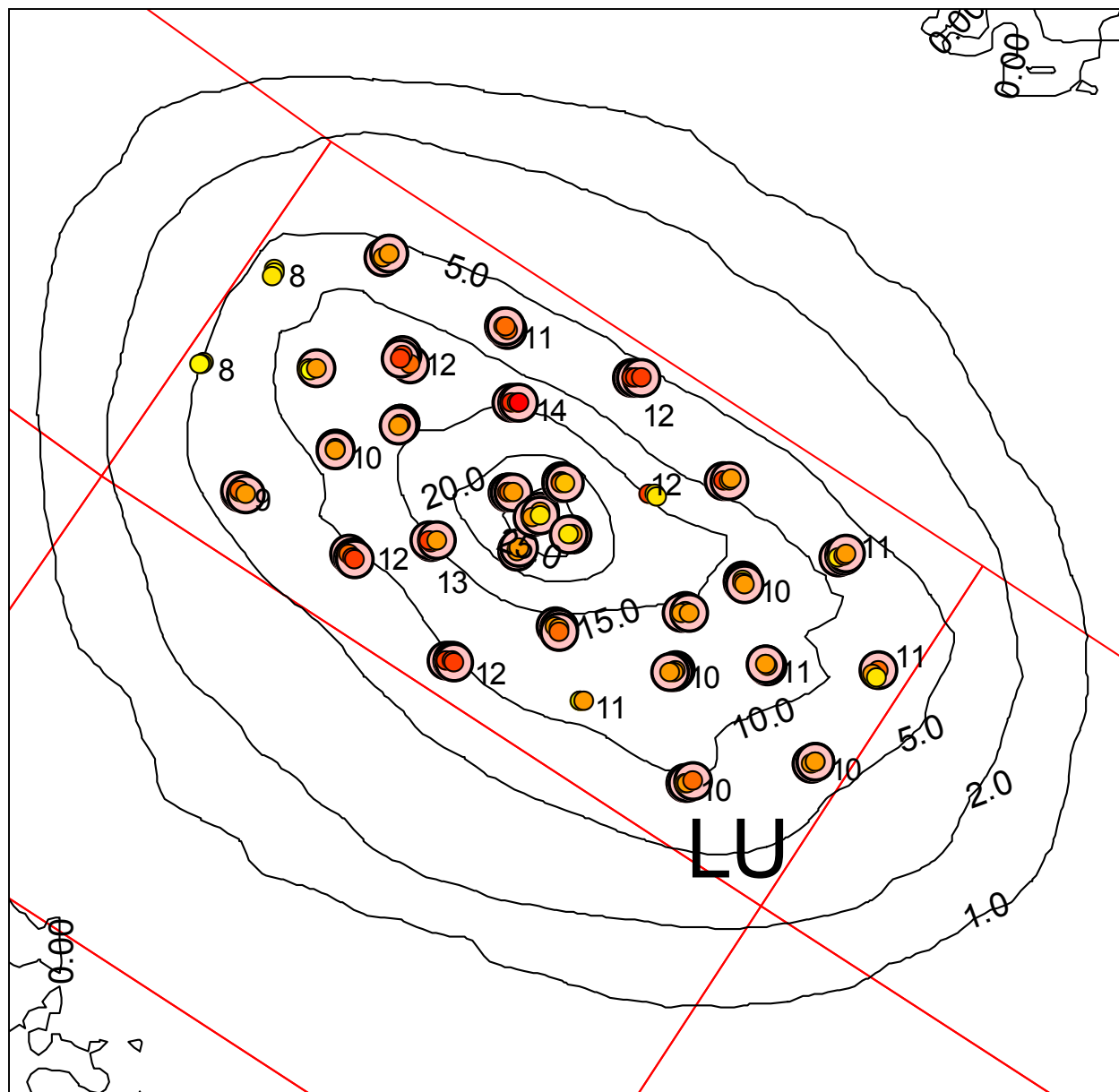

Figure 4-6. MDFATE hindcast simulation of LU25 and SPI inferred cap thickness (centimeters). MDFATE simulation had no tidal currents and included stripping of sediments. Solid lines are MDFATE cap thickness contours (x.0) in centimeters, colored dots indicate SPI stations, SPI thicknesses are in centimeters (whole numbers), pink dots are locations where cap thickness exceeded SPI penetration depth

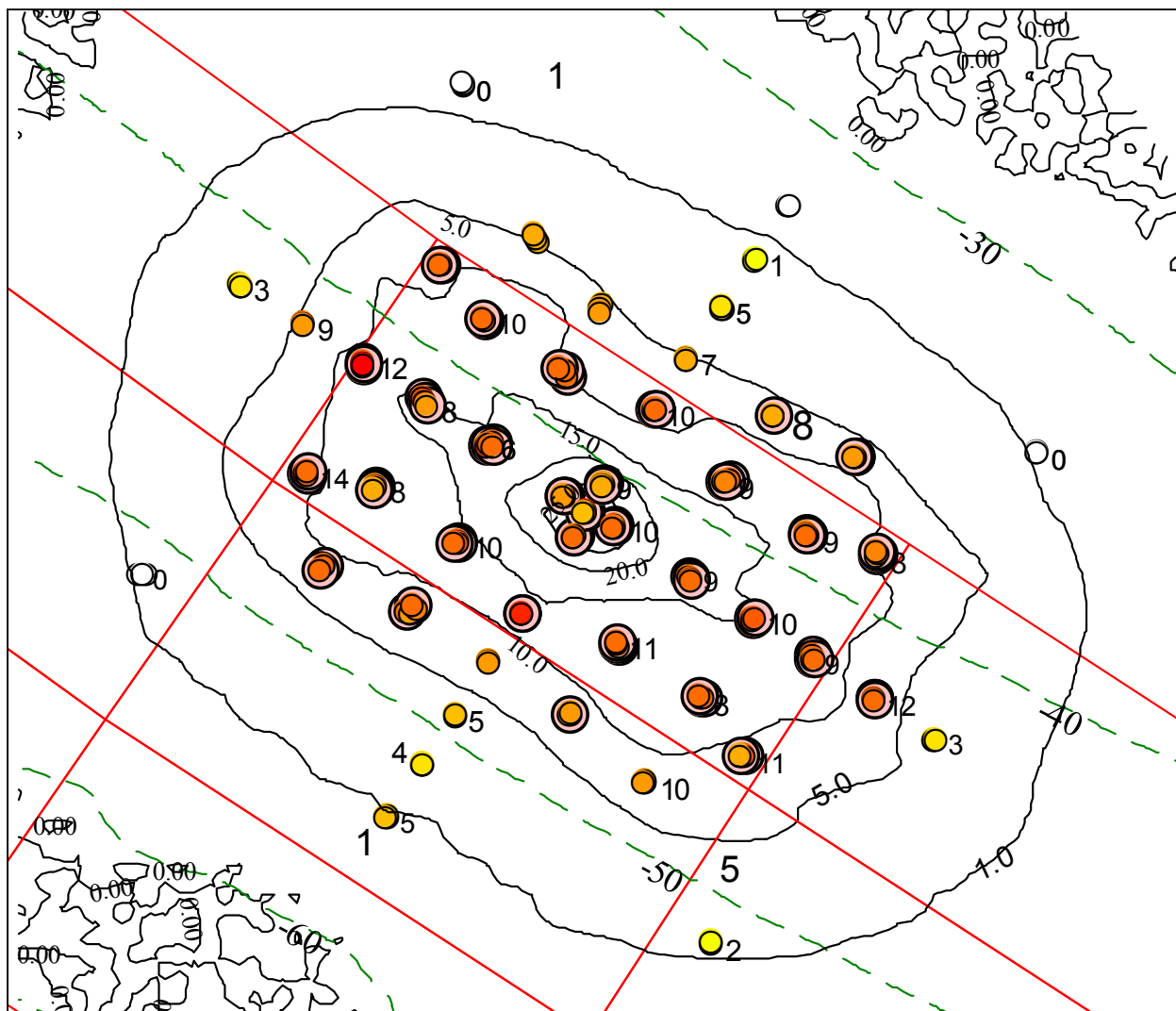

Figure 4-7. MDFATE simulation of LU45, without tidal currents, and including stripping of sediments. Depth contours (x.0) are MDFATE cap thickness in centimeters, colored dots indicate SPI stations, SPI thicknesses are in centimeters (whole numbers), pink dots behind colored dots are locations where cap thickness exceeded SPI penetration depth

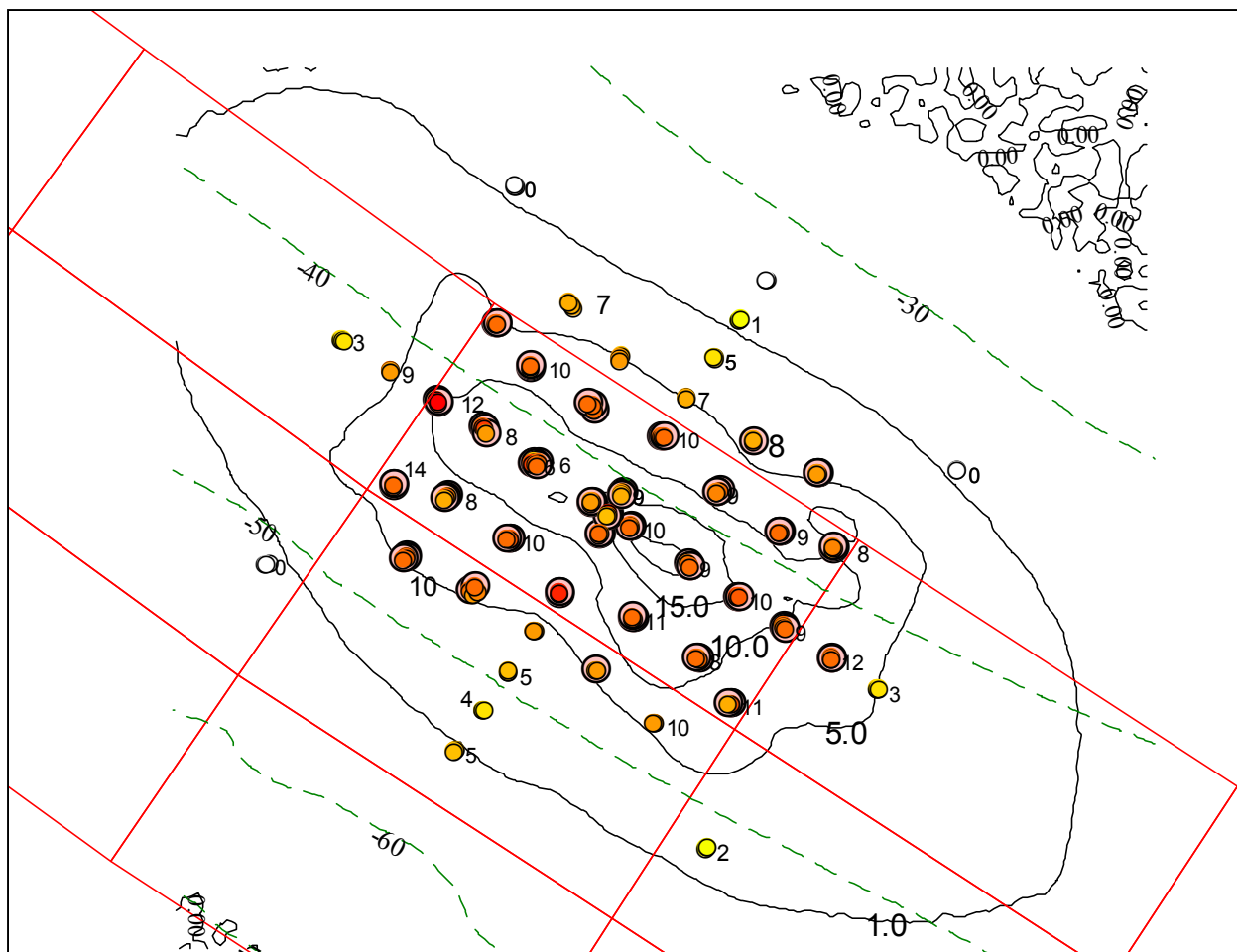

Figure 4-8. MDFATE hindcast simulation of LU45 and SPI inferred cap thickness (centimeters). MDFATE simulation had tidal currents and included stripping of sediments. Solid lines are MDFATE cap thickness contours (x.0) in centimeters, colored dots indicate SPI stations, SPI cap thicknesses are in centimeters (whole numbers), pink dots behind colored dots are locations where cap thickness exceeded SPI penetration depth. Dashed green contours are water depths in meters

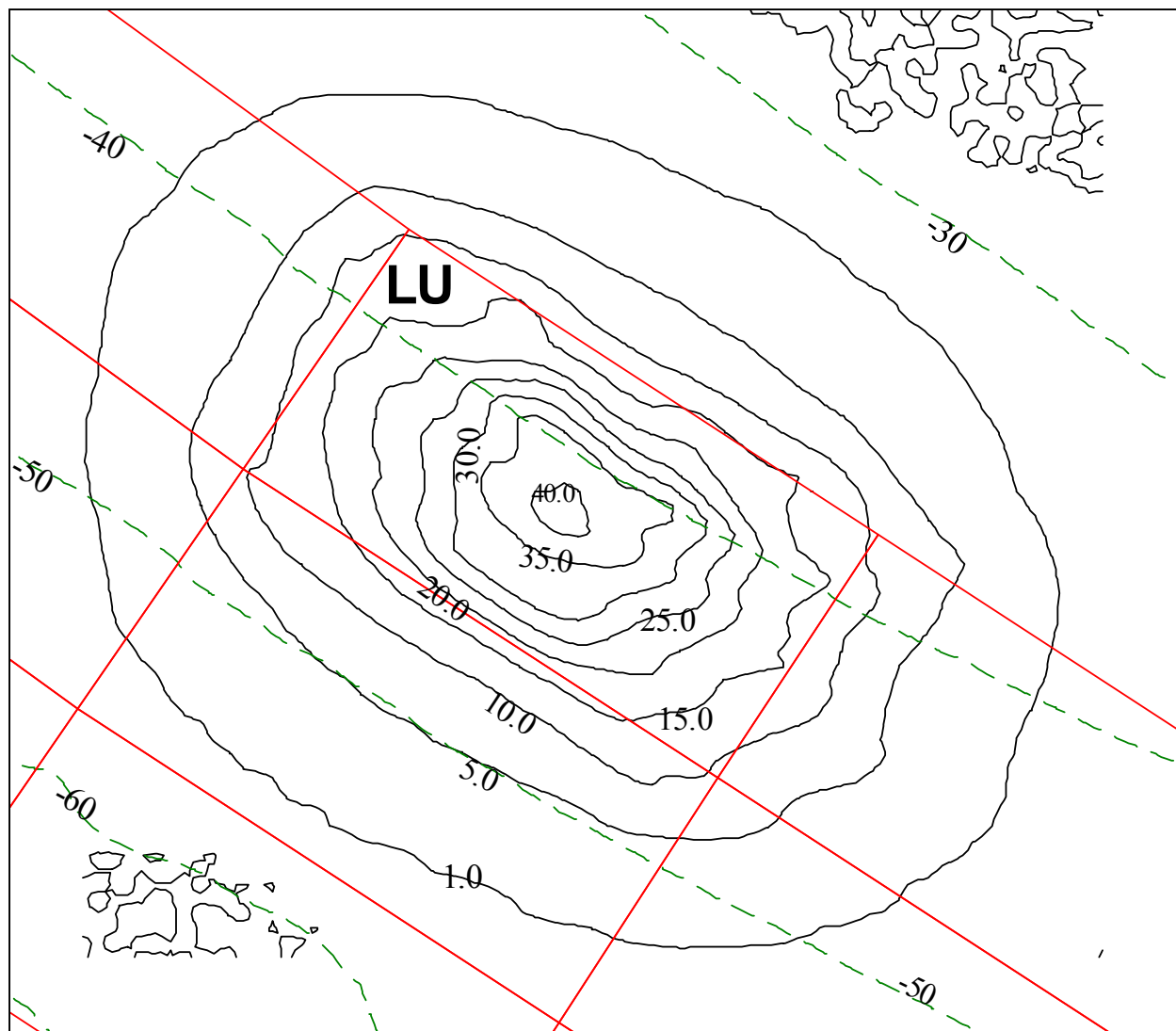

Figure 4-9. MDFATE simulation of LU71, without tidal currents, and including stripping of sediments. Solid contours are MDFATE cap thicknesses in centimeters, dashed contours are water depths in meters

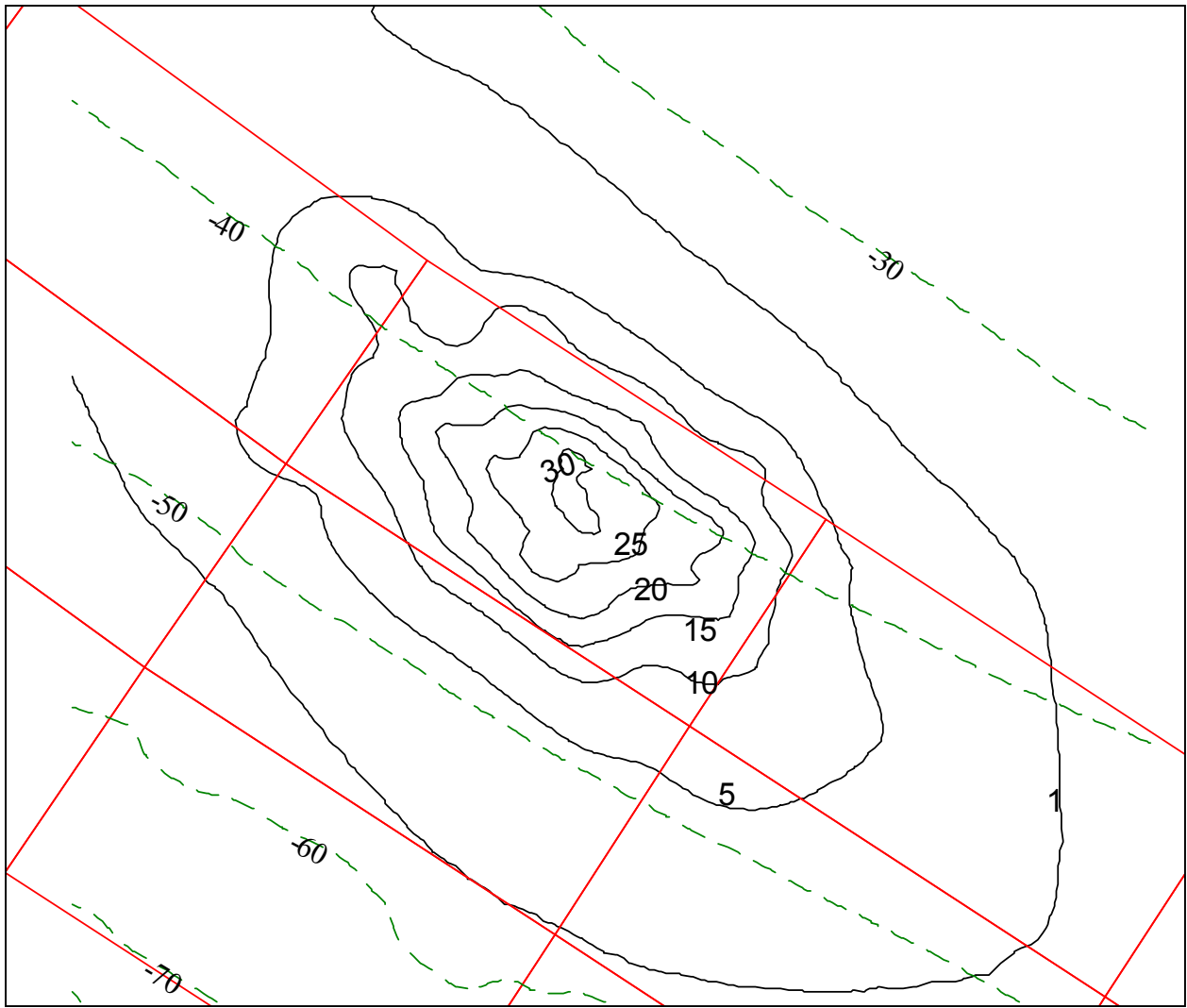

Figure 4-10. MDFATE simulation of LU71, with tidal currents, and including stripping of sediments. Solid contours are MDFATE cap thicknesses in centimeters. Dashed contours are water depth in meters

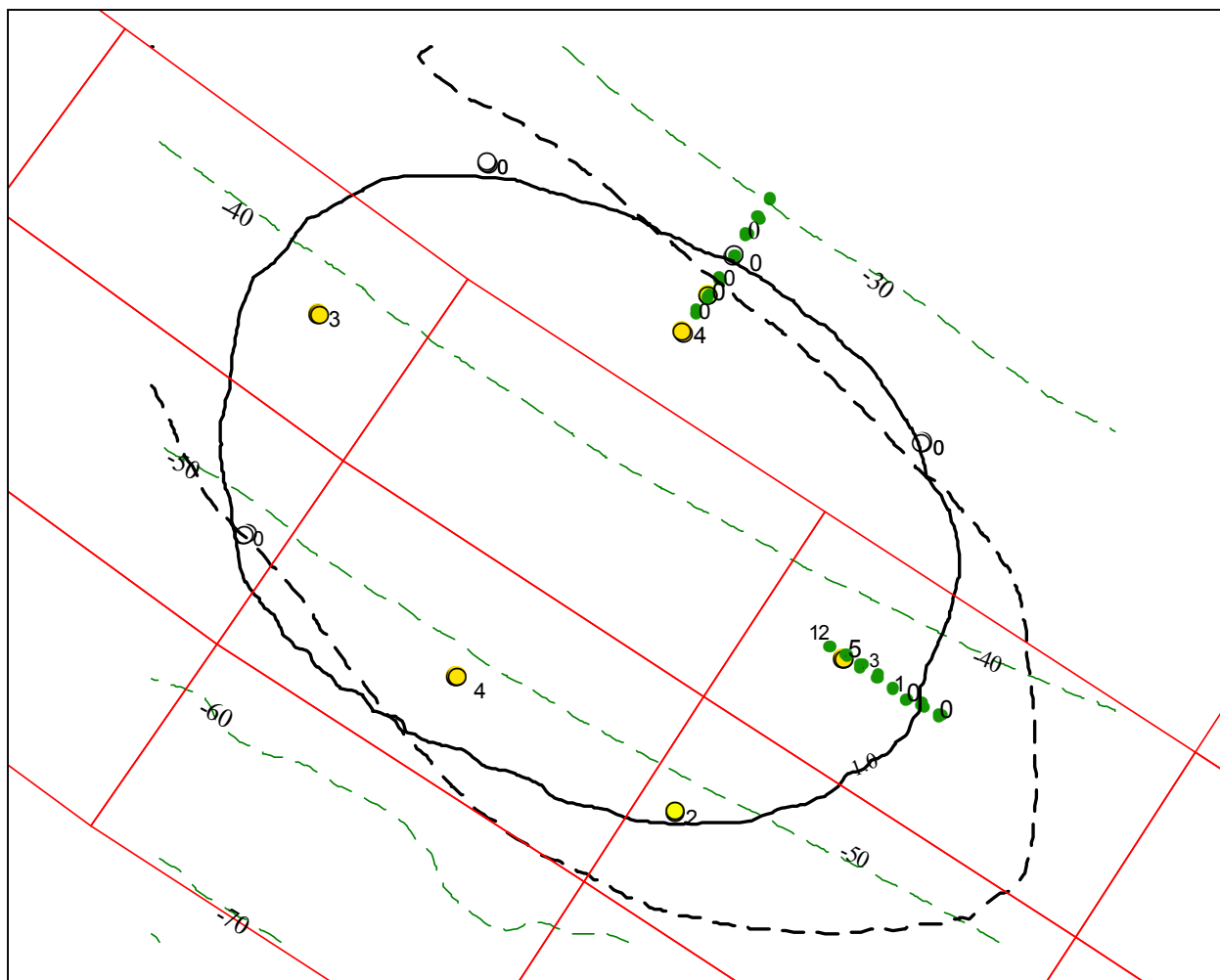

Figure 4-11. MDFATE LU71 hindcast simulation predicting maximum cap extent compared to SPI measurements. Solid black line is 1-cm contour from the MDFATE LU71 hindcast simulation without tidal currents, dashed black line is 1-cm contour from LU71 hindcast simulation with tidal currents. Colored dots are SPI cap thickness measurements, number next to dots are SPI cap thickness measurements

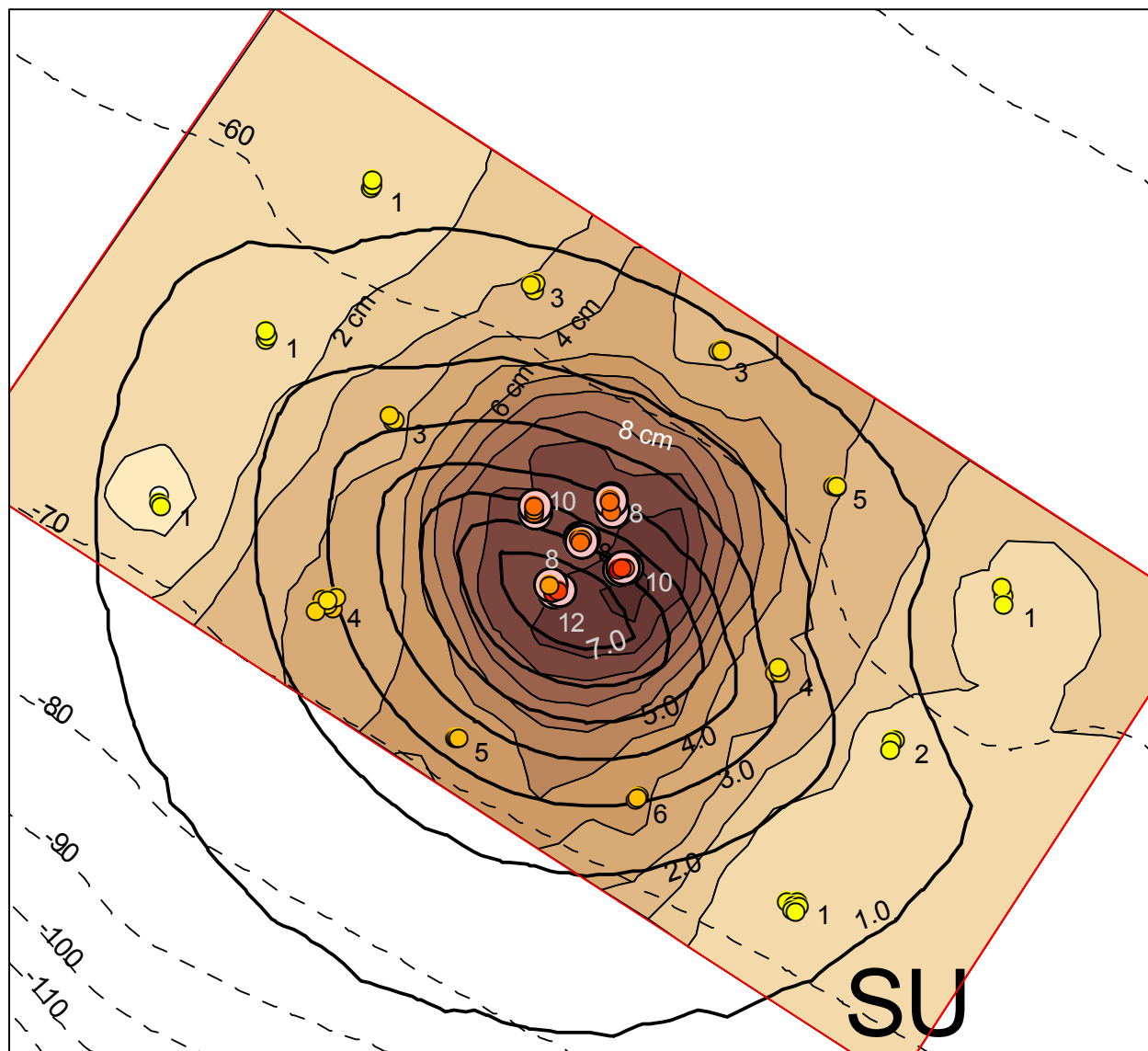

Figure 4-12. MDFATE hindcast simulation of SU5 and SPI inferred cap thickness (centimeters). MDFATE simulation had tidal currents and included stripping of sediments. Bold black lines are MDFATE cap thickness contours (x.0) in centimeters, colored dots indicate SPI stations, SPI cap thicknesses are in centimeters (whole numbers), pink dots behind colored dots are locations where cap thickness exceeded SPI penetration depth. SPI contours and color ramp (light to dark brown) are based on average thickness and are labeled as 2 cm, 4 cm, etc. Dashed green contours are water depths in meters

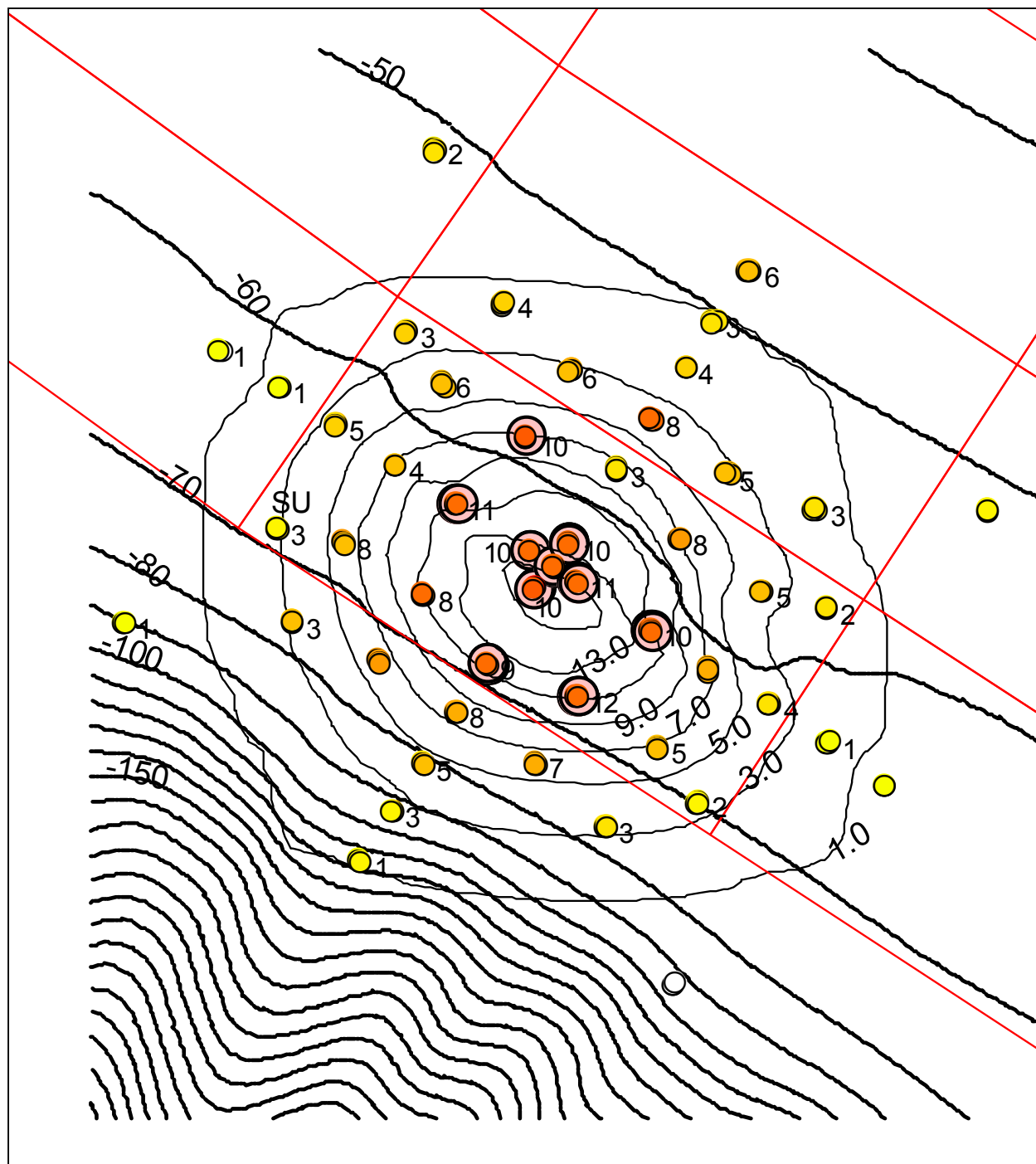

Figure 4-13. MDFATE hindcast simulation of SU21 and SPI inferred cap thickness (centimeters). MDFATE simulation had tidal currents and included stripping of sediments. Solid black lines are MDFATE cap thickness contours (x.0) in centimeters, colored dots indicate SPI stations, SPI cap thicknesses are in centimeters (whole numbers), pink dots behind colored dots are locations where cap thickness exceeded SPI penetration depth. Dashed black lines are depth contours in meters

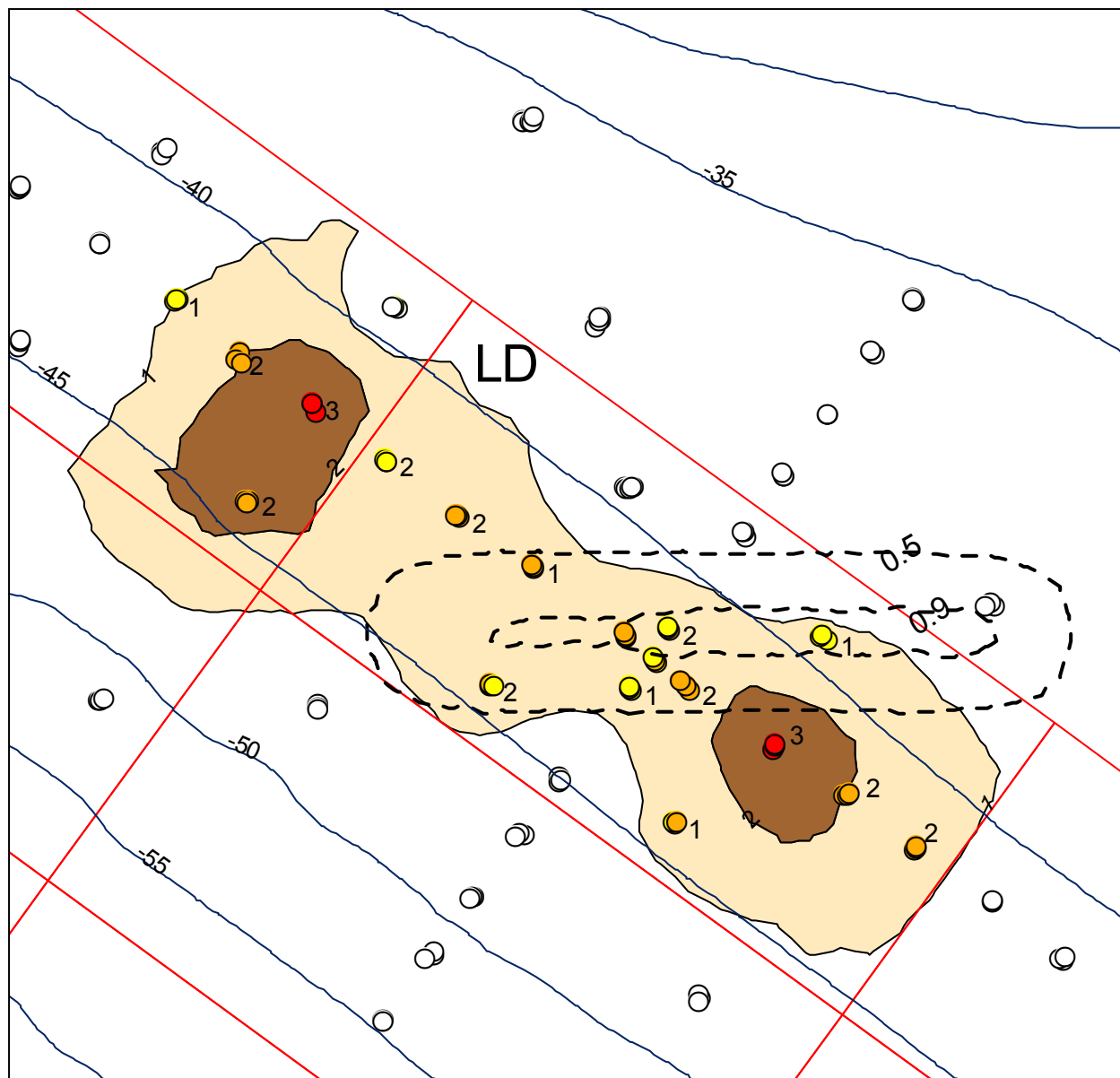

Figure 4-14. MDFATE hindcast simulation in spreading mode of LD1 placement and SPI inferred cap thickness (centimeters). Bold dashed lines are MDFATE cap thickness contours (x.0) in centimeters, brown dots indicate SPI stations, SPI thicknesses are in centimeters (whole numbers). SPI cap thickness measurements in centimeters are also indicated by brown color ramp and black contours, and labeled as integers. Water depth contours are in meters (e.g., -45)

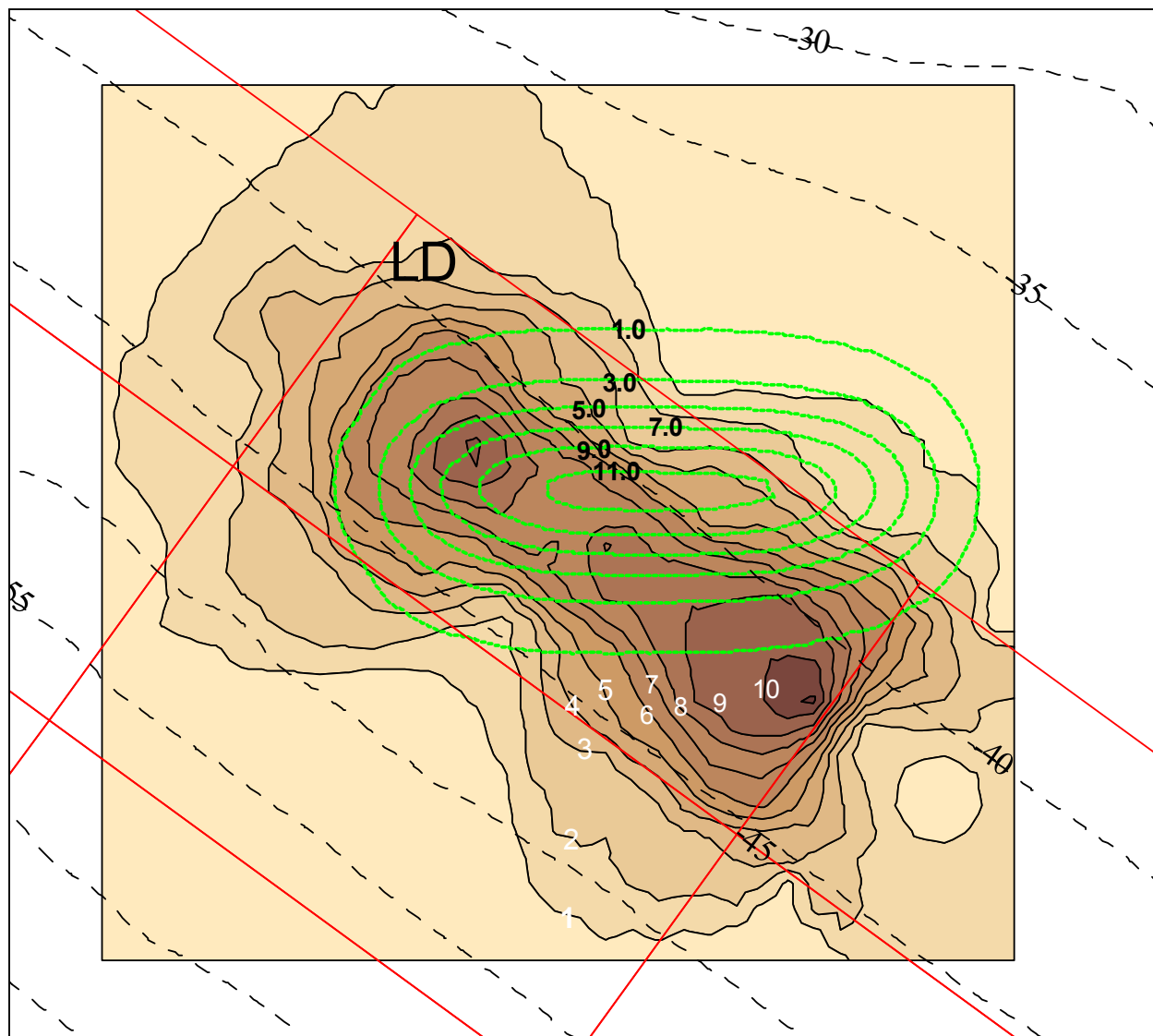

Figure 4-15. MDFATE hindcast simulation in spreading mode of LD9 placement and SPI inferred cap thickness (centimeters). MDFATE simulations contours are in centimeters, bright green, and labeled with decimals. SPI cap thickness measurements in centimeters are indicated by brown color ramp and black contours and labeled as integers. Water depth contours are in meters and displayed as dashed lines

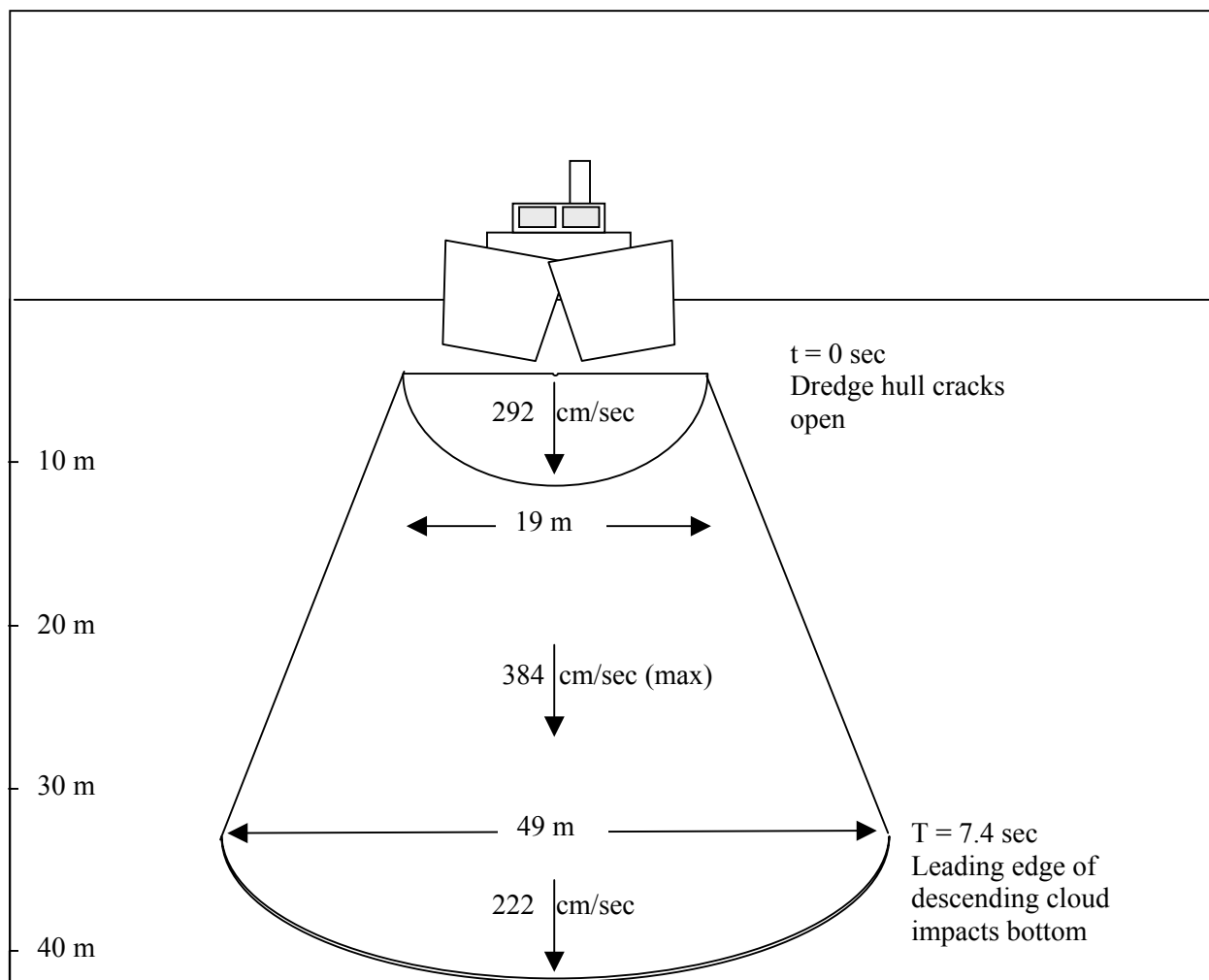

Figure 4-16. Time sequence of descending jet during LU1 placement as predicted by STFATE simulation

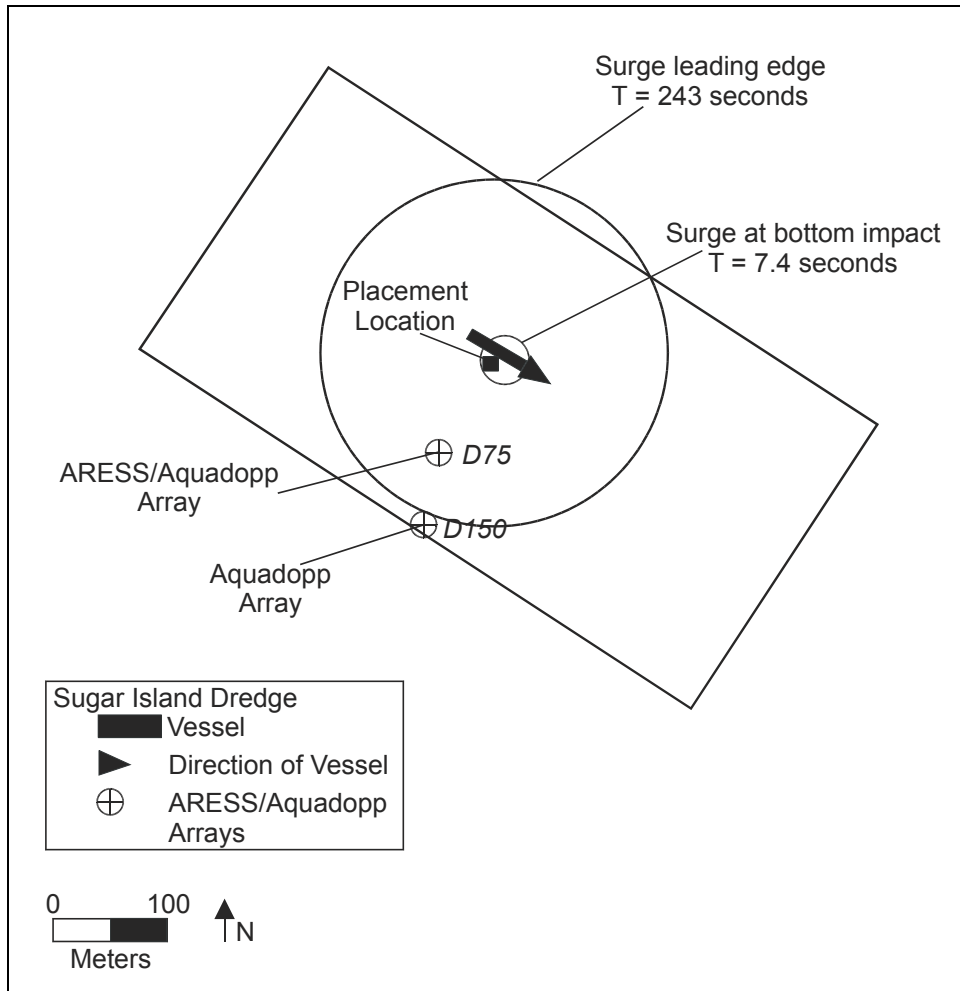

Figure 4-17. Plan view of time/spatial spreading of descending jet for LU 1 placement relative to ARESS quadrapod locations

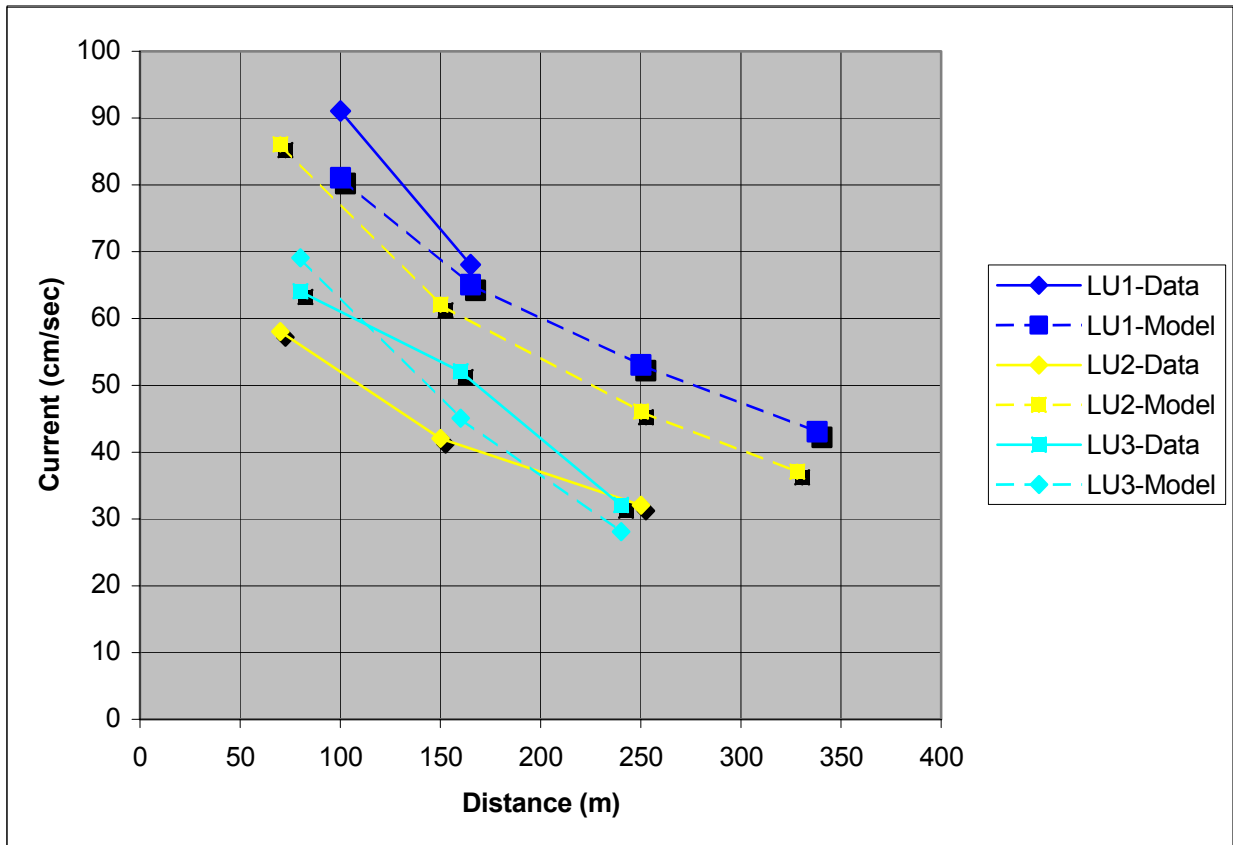

Figure 4-18. STFATE predictions (model) vs. measured bottom surge speeds (data) for placements LU1, LU2, and LU3

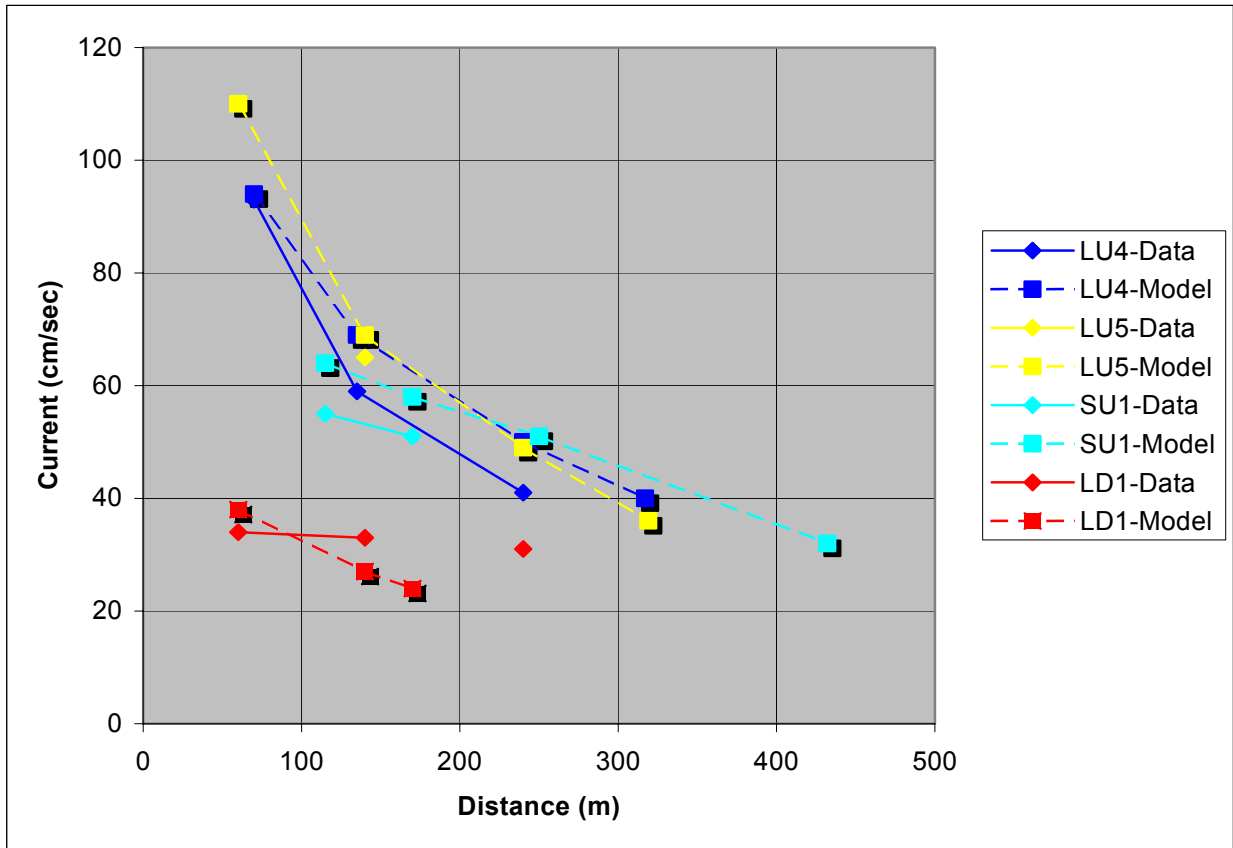

Figure 4-19. STFATE predictions (model) vs. measured bottom surge speeds (data) for placements LU4, LU5, SU1, and LD1

5 Discussion and Application of Results

5	Discussion and Application of Results.....	5-1
5.1	Discussion of Pilot Results Relative to Objectives.....	5-1
5.1.1	Variability in cap thickness.....	5-1
5.1.2	Sediment resuspension and mixing.....	5-2
5.1.3	Cap material dispersion.....	5-3
5.1.4	Influence of site conditions.....	5-4
5.1.5	Short-term isolation.....	5-5
5.1.6	Ability to monitor.....	5-5
5.1.7	Operational and monitoring approaches.....	5-5
5.1.8	Accuracy of model predictions.....	5-6
5.1.9	Improvement of the knowledge base.....	5-7
5.2	Application of Pilot Study Results.....	5-10
5.2.1	Full-scale cap design.....	5-10
5.2.2	Full-scale capping operations.....	5-13
5.2.3	Future monitoring.....	5-15
5.3	Conclusions and Recommendations.....	5-16
5.3.1	Conclusions.....	5-16
5.3.2	Recommendations for long-term monitoring of pilot study cells.....	5-17

5.1 Discussion of Pilot Results Relative to Objectives

This section provides a summary of the pilot study results as they relate to the objectives of the pilot study as defined in the Operations and Monitoring Plan (Palermo 2000). This information is presented in the context of each of the nine pilot study objectives provided in Chapter 1. For quantitative results, consult Chapters 3 and 4.

5.1.1 Variability in cap thickness

Objective 1. Demonstrate that an appropriate cap thickness can be placed with an acceptable level of variability in cap thickness. A cap thickness in excess

of 15-25 cm was successfully constructed over the central portion of one of the target cells using multiple placements to gradually build up the cap thickness. The area capped and the thickness as placed appropriately demonstrated the ability to construct a full design cap thickness. Greater design cap thicknesses can be placed in stages using similar placement methods.

The results of the monitoring program indicate that the cap thickness as placed was uniform, with local variations in thickness of only a few centimeters across those areas that received what could be considered a full cap application during the pilot study. This result held true for both the conventional method of placement and the spreading method of placement, but the spreading method resulted in somewhat greater uniformity.

Conventional point placements resulted in a pancake-like configuration with an overall evenness and smooth gradients in the lateral spread of material around a central point of impact for each placement. These placements resulted in a central portion with uniform thickness with a consistent decrease in thickness toward the edges. Sequential point placements were successfully managed to construct caps with an overall uniform thickness over larger areas.

For spreading placements, the cap deposit was uniformly distributed on the seafloor on both sides of the track line, with some variation in thickness along the track line related to the variable rates of cap material release from the hopper dredge.

5.1.2 Sediment resuspension and mixing

Objective 2. Demonstrate that excessive resuspension of existing sediments and excessive mixing of cap and contaminated sediments can be avoided. Resuspension and mixing of cap material with the EA sediment were well within the preproject expectations and therefore were not considered excessive. There was no evidence of mass sediment movement, turbidity flows, or slumping, indicating that cap placement did not result in excessive resuspension or mixing of sediment. Point placements resulted in some measurable resuspension as anticipated, and spreading placements resulted in less resuspension than the point placements.

Sediment cores and sediment profile images indicated some physical disturbance to the EA sediment layer due to placement of the cap, but the degree of disturbance and mixing was within the expected vertical range of a few centimeters.

The plumes resulting from cap placement and seafloor resuspension dissipated relatively quickly as predicted by modeling, as indicated by decreasing TSS concentrations within about 30 min of the initial placement event. Some of the later placements at the same location resulted in higher TSS levels, but less resuspension of EA sediment, likely due to shielding from direct impact by the cap material already in place and the fact that the surface layer of sediment that was resuspended was in part a mixture of EA sediment and cap material. The

plume tracking efforts also indicated that the plumes dissipated while traveling in a predominantly alongshore direction such that there is little potential for impacts on nearshore kelp beds.

Also, sediment profile and plan view images, side-scan sonar and sub-bottom profiling indicated no apparent disturbance to the in-place sediments outside the cap material footprint, and no evidence of sediment instability or deformations.

Lastly, the measurements of near-bottom currents during placement events showed that relatively strong, horizontal currents within the radially spreading bottom surge were confined close to the placement site; beyond, currents were insufficient to induce sediment resuspension.

These results all indicate impacts related to disturbance and resuspension of the EA sediments during cap placement were limited to the initial placements in a given area, and that impacts can be avoided by proper sequencing and spacing of placements. Further, the level of impacts observed is within the expected ranges and would not be of concern for a full-scale project.

5.1.3 Cap material dispersion

Objective 3. Demonstrate that excessive losses of cap materials can be avoided. Based primarily on the results from the STFATE and MDFATE simulations, and to a much lesser extent on the comparison of hopper volumes with as-placed cap dimensions and plume monitoring data, losses of cap material offsite to far field dispersion were likely in the range of 10 to 15 percent for Queen's Gate sediments and 5 to 10 percent for A-III sediments. Note that these estimates are considerably lower than the conservative prepilot estimates of 30 percent.

Monitoring of plumes from multiple placement events showed consistent patterns of initially high levels of suspended sediments followed by a rapid initial settlement of coarser particles and flocculating material, followed by a longer-term dilution and settling phase where the water column returned to near background levels within about 2 hr. Considering the measured drift velocities, only a small mass of cap material would be expected to drift offsite.

Array data on bottom surge velocities showed no evidence of significant cap material flows downslope. SPI images indicated no deposition in areas outside of the immediate area of impact and showed that the extent of the cap closely corresponded to model predictions. Plume measurements indicated no significant losses of cap material via far field dispersion. Volumes of cap material accumulation also closely corresponded to model predictions. These data support the conclusion that cap material losses were not excessive and predictions of volumes needed to create a cap are reasonably accurate.

5.1.4 Influence of site conditions

Objective 4. Determine, to the degree possible, the effects of variable cap material type, seafloor slope, water depth, and placement method (e.g., conventional versus spreading) on cap thickness and sediment displacement and resuspension. The respective effects of slope, water depth, material type, and placement method could not be fully determined with the constraints of the pilot study design. However, comparisons of effects of shallow versus deeper cells for point placements and point placement versus spreading placements in shallower water depths are possible.

The pilot cell at deeper water depths exhibited steeper slopes, so the combined effects of seafloor slope/water depth were observed for point placements of Queen's Gate material. Spreading placements with borrow area sand at a deeper cell were eliminated from the study due to funding constraints, so no comparison of effects of depth/slope for spreading placements was possible. Monitoring results indicated a slight preferential lateral spreading (only tens of meters) in the downslope direction as compared to upslope for conventional point placements in both the shallow and deeper cells. Cap thickness was slightly thinner in the deeper cell as compared to the shallower cell for comparable capping effort, but the overall distribution of cap material was similar in the two cells. These results indicate that water depth and seafloor slope appeared to have only a minor influence on cap thickness and the degree of lateral spreading on the seafloor.

Point placements of Queen's Gate material and spreading placements of borrow area sand were made at the shallow water depth cells, allowing for a comparison of the combined effect of placement method/cap material. The effects of placement method/cap material were clearly distinguishable from the standpoint of sediment resuspension and mixing of cap material with EA sediments. For conventional placements of Queen's Gate cap material, disturbance to EA sediments and water column resuspension due to cap placement was most pronounced following the initial placements at a given location, and was reduced after the buildup of multiple placements provided a shielding effect. The spreading placement approach using A-III borrow sand appeared to result in even less resuspension and disturbance to in-place sediments than conventional placement, but the effect of placement method alone cannot be fully differentiated.

Conventional placement at the two different water depths resulted in no appreciable difference in the magnitude of resuspended sediments. In contrast, higher water column DDE concentrations were observed for placement in the deeper cell, but this was consistent with the higher DDE concentrations in the sediments at this deeper location. Total suspended sediment (TSS) levels were quite comparable for the two cells consistent with the expectation that the energy levels of the descending sediment jets would be similar regardless of depth (due to conservation of momentum) and result in equivalent EA sediment disturbance.

The overall results of the pilot placements in all cells showed that caps were successfully constructed in both deep and shallow water and using both spreading and point placements.

5.1.5 Short-term isolation

Objective 5. Demonstrate the effectiveness of the cap with respect to short-term isolation of contaminants during the initial vertical advective flow resulting from sediment consolidation. As cap material is placed on the EA sediment, some consolidation of the EA layer will occur resulting in an advective flow of pore water and potential migration of contaminants into the cap. The objective to demonstrate the impact of this process on the contaminant profile within the cap was not met due to the inability to collect quality paired core samples before and immediately following cap placement.

5.1.6 Ability to monitor

Objective 6. Demonstrate the ability to monitor operations and success. The pilot study demonstrated that a cap can be successfully placed and monitored on the PV Shelf. Although some limitations were evident with some of the monitoring tools (see Section 5.1.7), the monitoring equipment and techniques proved generally effective in obtaining the desired data and were generally effective across the range of site conditions encountered in the pilot study.

The combination of monitoring tools was critical to success and overcame limitations of each individual tool. The resulting redundancy proved invaluable because data were available from one or more independent approaches to offset limitations of individual methods. This improves the confidence that can be placed on the conclusions of the study.

The monitoring conducted for the pilot focused on the ability to construct the cap and related short-term processes only. Other issues such as biological recolonization of the cap and long-term changes in the cap must be addressed by follow-on monitoring efforts.

5.1.7 Operational and monitoring approaches

Objective 7. Evaluate and modify, where needed, all operational and monitoring approaches. Both the conventional placement and spreading modes of operation proved successful in constructing the cap. These operational approaches were generally carried out in accordance with the pilot study design.

The spreading method of operation did not result in a complete dissipation of momentum and particle settling for the released material as expected from modeling predictions. The material traveled to the seafloor quicker than predicted by the MDFATE model simulation, resulting in less horizontal spreading and more energy at seafloor impact than expected. Some reduction in

the rate of release or increased vessel speed during release for the spreading mode may result in a greater distribution of energy for the release. However, observations from the pilot study indicated that the level of sediment resuspension using the spreading method of placement was acceptable without achieving true particle settling.

Some of the monitoring tools were ineffective, but these limitations were offset by the strengths of other tools. The sub-bottom profiles could distinguish the presence of a cap layer, but could not resolve the thickness of the layer due to a similarity of acoustic signature of the EA and cap materials and the relatively thin cap thickness as placed.

The use of freely suspended video cameras to measure surge velocity proved ineffective due to vessel maneuvering requirements, and a tripod deployment should be considered for any future efforts. The gravity coring and vibracoring equipment used for the pilot study proved ineffective in obtaining high quality core samples in thicker cap deposits, and improved methods should be found prior to any full-scale monitoring efforts at the site.

The monitoring program for a full-scale project would be much less intense than this pilot project and the likelihood of time constraints leading to problems with the monitoring program would be greatly reduced.

5.1.8 Accuracy of model predictions

Objective 8. Demonstrate the ability of existing numerical models to accurately simulate cap placement. Two types of modeling efforts were conducted for the pilot study. Model predictions were performed prior to collection of field data to guide the design of the operations and monitoring efforts and define the processes of importance. Model simulations were also conducted in a hindcast mode following the field data collection efforts to evaluate the accuracy of the models in simulating the capping processes using the actual data collected as inputs to the models. The model predictions did not accurately match the field results in all cases but were helpful in defining the operational and monitoring requirements for the pilot study. The hindcast model simulations more closely matched the field observations, and these results indicate the models can be used for future predictions of capping operations.

The actual behavior during an individual placement event of the released sediment compared well with the hindcast simulations made by the STFATE numerical modeling. Comparisons of average bottom surge speeds computed by STFATE agreed within 15 percent of those determined from bottom mounted current meters for six of the seven simulations. In addition, the behavior of the suspended sediment plume computed by STFATE, e.g., its direction of movement at different depths in the water column and its overall size, agreed with the data collected by a BBADCP. Comparing TSS concentrations computed by STFATE with those measured in water samples was more difficult because virtually all of the samples were collected very near the sea bottom in the surge. STFATE does not provide TSS concentrations at different water depths until the

energy possessed by the bottom surge is dissipated. However, computed concentrations and those from the water samples generally agreed after the dissipation of the bottom surge.

The overall spread and thickness of the deposits over the cells compared well to the simulated deposit geometry from the hindcast MDFATE (multiple placement fate) model, made following the actual placements using monitoring data. MDFATE generally resulted in a modest to slight overprediction of cap thickness by the model for the multiple placement simulations. This overprediction was likely due to the inability to model residual currents and the inability to model resuspension of existing seafloor sediments. Maximum extent of the mounds as determined by the 1-cm contour from SPI measurements was well predicted by MDFATE. MDFATE simulations using residual (net) currents resulted in predictions of large offsets of the deposited sediment from its point of release at the sea surface, but large offsets were not observed in actual field operations. To overcome this problem, mound placements in the hindcast mode were simulated without residual currents.

5.1.9 Improvement of the knowledge base

Objective 9. Improve the knowledge base contributing to decisions on implementation of a full-scale cap. The purpose of the pilot capping study was to collect data on a limited scale that can be used to evaluate the ability to construct a full-scale cap, including the effects of site conditions, cap material type, and placement methods on cap construction. These data will be used by EPA in the decision-making process that will evaluate the feasibility and effectiveness of constructing a full-scale cap on the Palos Verdes Shelf.

The pilot study significantly increased the PV Shelf knowledge base with data applicable to construction of a full-scale cap where these data were not before available:

- a. Behavior characteristics of two cap materials placed in varying water depths using three placement methods, as discussed in Chapter 3. This study concludes that both cap material types were successfully placed using both conventional and spreading placement methods in the locations intended and to the thickness predicted and planned without creating an unacceptable disturbance (e.g., mass sediment movement, turbidity flows, or slumping) to the existing seabed. This information is crucial for selecting the appropriate cap material type and placement method to be used to construct a full-scale cap. However, it should be noted that the amount of data on the direct pump-out method was limited. Decisions on using this method as part of a full-scale capping project would require additional evaluations.
- b. Behavior characteristics of the cap material during and after cap construction operations, as discussed in Chapter 3. This study concludes that plumes generated by both conventional and spreading cap material placement methods did not impact the water column quality for a long

duration and were successfully managed so that nearby kelp beds and LACSD outfalls were not impacted. This information is crucial for evaluating the potential negative impacts to the area nearby the PV Shelf during full-scale cap construction.

- c. Effectiveness of both conventional and spreading placement methods, as discussed in Chapter 3. This study concludes that both conventional point placement and spreading placement methods were successful in placing cap material where these materials were intended and in the thickness predicted and planned. This information is crucial for evaluating the appropriate placement method to be used for constructing a full-scale cap.
- d. Logistics requirements, including interdisciplinary team makeup; onshore facilities for sample preparation, waste materials handling, data reduction, project management; and monitoring equipment and vessels, as discussed in Chapter 3 and in the SAIC Monitoring Report. This study required the cooperation of a multidisciplinary team of about 20 nationally-known experts from two contractors, two EPA offices, four USACE Districts and Centers, along with the facilities, equipment, materials, and vessels to collect, analyze, and interpret data collected from 105 surveys conducted at 1,240 stations before, during, and after 102 placement events. This study successfully conducted all cap construction activities using the people, facilities, equipment, and vessels previously described, all within the Queen's Gate deepening project time frame without any impacts to the Port of Long Beach schedule and budget. This study concludes that the monitoring team skills and the monitoring approaches used can be successfully applied to monitor the construction of a full-scale cap.
- e. Operations requirements, including vessel types, dredging rates, hopper volumes, and transit times, and economies of conducting cap construction with ongoing navigational projects (e.g., channel deepening), as discussed in Chapter 2. This study concludes that placement operations become more accurate and efficient as placements proceed. This information is crucial for evaluating the potential impacts, costs, and economies of scale associated with full-scale cap construction.
- f. Reasonable correlations of numerical model predictions and the monitoring data collected, as discussed in Chapter 4. This study concludes that the numerical models used were in reasonable agreement with the monitoring data collected and would be useful tools for full-scale project design.
- g. Minimum sampling and analysis requirements for monitoring cap construction. This study concludes that the ADISS system, ARESS and ADCP, SPI (plan view and sediment profile camera with modifications), sediment coring (with modifications), side-scan sonar, and water column monitoring provided monitoring information that was representative of the environmental conditions before, during, and after pilot cap

construction. These methods and instrumentation should be used to monitor full-scale cap construction.

- h.* Reasonable predictions that capping will not likely cause unacceptable resuspension of EA sediments into the clean cap material or the water column, adverse impacts to kelp beds, or submarine mudflows, as discussed in Chapter 3. This study concludes that there were no long-term adverse impacts to water quality and nearby sensitive areas during the pilot cap construction. This information is crucial for evaluating the potential adverse impacts and the minimum monitoring activities to be conducted during construction of a full-scale cap.
- i.* Additional baseline EA sediment characterization and extent data, as discussed in the SAIC monitoring report. This study collected additional data that further defines the nature and extent of the contaminated sediments on the PV Shelf.

As the pilot study data were analyzed, a number of areas where the knowledge base could be further increased were identified. These areas, along with recommendations for addressing these areas and the implication for constructing a full-scale cap, are identified as follows:

- a.* Coring artifacts. Artifacts observed in the gravity cores decreased the confidence with which design thickness, variations in cap thickness, the degree of EA sediment and cap material mixing, EA sediment resuspension, and correlation with model predictions and hindcasts could be assessed. However, the data collected were sufficient to answer the pilot study questions with only minor uncertainty. Additional data could be collected to address these limitations, but these data are not considered critical to evaluate the ability to construct a full-scale cap.
- b.* Data density. Data density was not sufficient to statistically measure variations in cap thickness and EA sediment resuspension; however, the data collected were sufficient to answer the pilot study questions. Additional data could be collected to address these limitations, but these data are not considered to be critical to evaluate the ability to construct a full-scale cap.
- c.* Study design. As a result of the pilot cap study, additional interest has been generated in addressing the effects of EA sediment consolidation on vertical contaminant transport, cap effectiveness with respect to DDE flux remobilization and bioavailability, long-term cap stability, ability to place a cap near underwater structures (e.g., the LACSD outfalls), bioturbation, lateral transport of EA sediments from adjacent uncapped areas, and sources and deposition and accumulation rates of particles on the cap. The pilot study was not designed to directly answer these questions, although selected data collected during the pilot study can be used to address some of the issues previously listed. Additional data could be collected to address these areas of interest, but the pilot cap study is considered to have generated the data needed to evaluate the ability to construct a full-scale cap.

The overall results of the pilot study clearly demonstrated the ability to construct a cap on the PV Shelf (Figure 5-1 shows the estimated cap coverage for the pilot study within and around the pilot cap cells). Detailed discussions on how the results of the pilot study can be translated to any future full-scale capping project are provided in Section 5.2.

5.2 Application of Pilot Study Results

This section describes how the pilot study operations, monitoring, and modeling results can be applied to any future full-scale capping project on the PV Shelf. Comparisons are made between pilot study results and predictions, and recommendations contained in the prepilot study capping options report (Palermo et al. 1999). Applicability of the pilot study results to full-scale cap design, full-scale cap placement operations, and full-scale project monitoring are discussed.

5.2.1 Full-scale cap design

Cap design for a full-scale project refers to the composition and thickness of the cap. Design elements include selection of cap materials and the determination, through specific evaluations, of the total cap thickness required to account for the various processes influencing cap effectiveness in the long term.

The total design cap thickness for a full-scale project must consider components related to erosion, bioturbation, consolidation, chemical isolation, and operational factors related to the variability in cap thickness and the degree of mixing of cap and EA sediment. The pilot study results provide data that can be directly used in a full-scale cap design to include selection of the cap materials and the operational components of the cap design.

Selection of cap materials. Pilot study results indicated that both cap materials could be used for a full-scale project. However, distinct differences were observed resulting from placement of the two materials. Queen's Gate material resulted in higher water column losses during placement, higher resuspension due to conventional placements, higher energy within the lateral bottom surges due to conventional placements, and more difficulty in visually distinguishing interfaces between the cap and EA material. In contrast, the spreading placement of A-III borrow area material resulted in less resuspension and loss of EA sediment, lower surge energies, and, because of the color and grain-size characteristics of the A-III sand, a clearer visual interface between capping and EA sediments. However, a coarser sand such as the A-III material would have less contaminant adsorptive capacity and may also provide a lower quality substrate for benthic recolonization as compared to a silty sand such as Queen's Gate.

There were also operational differences between the Queen's Gate and A-III borrow materials. The borrow area sand could be loaded faster with the hopper dredge, and larger volume loads can be obtained as compared to Queens Gate

material. This means that more borrow area cap material can be delivered per transit out to the PV Shelf site, resulting in a faster construction rate.

Site characterization and selection of potential areas for capping. The present boundaries defining the footprint of the EA sediment deposit are defined by the USGS studies, based on core locations for that study. Additional data should be collected as a baseline to more clearly define the boundaries for any full-scale capping project, especially for the southeastern portion of the EA sediment footprint. The area recommended for capping in Palermo et al. (1999) was based on evaluations of erosion (as a function of water depth and cap material grain size) and seismic stability (as a function of seafloor slope). The areas considered for a full-scale capping project should be determined after more refined baseline data are collected.

Operational cap thickness component. Palermo et al. (1999) proposed a 10-cm operational cap thickness component, to account for possible variations in the as-placed cap thickness and mixing of cap material and EA sediment, and this was considered a conservative estimate. Based on the pilot study results, the variability of the cap thickness was limited to a few centimeters. Also, the thickness of the mixed layer of EA and cap material was limited to only a few centimeters, and only a portion of this total mixed thickness is attributable to applied cap material. Further, the mixed layer was evident more for the initial placements at a given location, and was reduced after the buildup of multiple placements provided a shielding effect. Based on these considerations, the operational cap thickness component for variation in placed thickness and mixing should be re-evaluated for full-scale cap designs and possibly reduced.

Erosion of a cap by natural processes. No cap thickness component for erosion was established in the prepilot study design. Rather, the erosion evaluation determined a water depth at which erosion could be considered negligible, thus establishing a landward boundary at the 40-m depth contour for the area recommended for capping. While the pilot study did not address long-term erosion processes acting on the shelf, data on the in situ void ratios and grain-size distributions of in-place cap material can be used in refining model estimates of erosion potential as a part of full-scale cap design.

Seismic stability. As for erosion, no cap thickness component for seismic stability considerations was established in the prepilot study design. The seismic evaluations determined a limiting slope for an acceptable level of seismic stability, thus establishing a seaward boundary at the 70-m depth contour for the area recommended for capping. The pilot study did not address seismic considerations, but data on in situ void ratios and grain-size distributions can be used in refining model estimates of stability under seismic loadings. Additional evaluations of seismic stability should be conducted as a part of any full-scale project design.

Bioturbation. Baseline data support a conclusion that sediment mixing by burrowing organisms is largely limited to the upper 15 cm or less of the sediment column. DDE concentrations increased markedly beginning about 12 cm downcore in cores from shallower areas (offshore areas of Cells LU and LD and

inshore areas of Cells SU and SD) and 8 cm downcore in cores from deeper areas (offshore areas of Cells SU and SD). In Cells SU and SD this was further supported by nonuniformity in grain size which showed decreasing silt and increasing clay with depth. These distributions are inconsistent with deep mixing which would cause such profiles to be uniform through the mixed zone. The prepilot study design considered a completely mixed surface layer of 15 cm due to bioturbation, with an additional 15-cm layer in which a biodiffusion process is active and maintaining these estimates appears to be reasonable.

Short-term cap contamination. During the February 2001 monitoring survey, the SPI photographs showed a visually distinctive layer of sediment that appeared to be overlying the cap sediments. We hypothesize that this layer may have several origins including (a) horizontal transport from off-cap locations (b) vertical transport from below the cap by burrowing organisms (c) settlement of cleaner sediment from the water column or possibly (d) the layer is not new sediment, but is only a visual distinctness that has developed within the cap. It is the first two of these potential causes that creates some concern for full-scale cap placement because of the potential to contaminate the surface of the newly capped areas. While these may be the causes for the observed layer, the small size of the pilot caps and the thinness of the caps where the observations were made could also overamplify the potential concern relative to a full-scale cap.

Placement of large sections of the full-scale cap in as short a time as practicable to full design thickness should help to minimize the potential for cap contamination via horizontal and vertical transport of EA sediment. Each additional increment of capped cells will reduce the unconfined EA source areas for horizontal transport. Minimizing potential for vertical transport by burrowers will require building a thickness that is 15 cm or more to discourage burrowers from seeking deeper, food-rich sediments that they can transport back to the surface.

Consolidation. Prepilot study design evaluations assumed no consolidation cap thickness component would be needed due to the sandy nature of the cap materials. Instead, the evaluation focused on consolidation of the EA sediment due to cap placement, and the resulting advective flow and its effects on the chemical isolation effectiveness of the cap. Consolidation of the EA layer due to cap placement was not measured in the pilot study due to the inability to collect quality paired core samples before and immediately following cap placement. However, the baseline sediment cores revealed that the upper 30 cm of EA sediments in the pilot cap study area were relatively well consolidated, to the extent that conventional gravity coring techniques were marginally successful at penetrating into the firm seafloor underlying the EA sediments.

Because the prepilot study design indicated effects of consolidation-induced advective flow on cap isolation effectiveness were minor, this absence of consolidation data should not significantly affect the design of a full-scale capping project on the shelf. However, consolidation data should be collected as a part of any monitoring program for any additional cap placement on the shelf.

Chemical isolation. Effectiveness of the cap for chemical isolation was evaluated in the prepilot study design using capping effectiveness models. The pilot study did not provide data directly related to the long-term isolation effectiveness of a full-scale cap. However, a number of parameters measured in the pilot study can be used in refined evaluations of cap isolation effectiveness, including data on density, grain-size distribution, and data related to degree of cap and EA sediment mixing, and depths of bioturbation. Also, possible refinements in the operational cap thickness component and bioturbation and biodiffusion depths can be used in refining model estimates of long-term cap effectiveness for isolation as a part of full-scale cap design.

Design cap thickness. A design thickness of 45 cm (considering all pertinent thickness components) for an isolation cap was considered adequate in Palermo et al. (1999). The design cap thickness for any full-scale project should be evaluated considering pilot study data on material properties and possible reductions in cap thickness components. The pilot study clearly showed that cap placement can be controlled and monitored, and that operations can be managed to achieve a specific cap thickness. These demonstrated capabilities should allow for a finer resolution of design cap thicknesses for a full-scale project.

5.2.2 Full-scale capping operations

Equipment selection. The hopper dredge *Sugar Island* proved very effective for the pilot study cap placement on the shelf. There was demonstrated operational flexibility using the *Sugar Island* for both point placements and spreading placements. Both placement methods proved operationally feasible, and there was no demonstrated need to modify the basic placement techniques. Hopper dredge use for a full-scale project is highly recommended.

Conventional placement methods. The conventional point placement method, with approximately 75-m spacing between point placement locations, resulted in an acceptable level of uniformity in cap thickness, and was successful in constructing a cap. Conventional placements at the points with the hopper dredge essentially stationary resulted in higher energy than predicted by modeling, although the level of disturbance and resuspension of EA sediments was acceptable. Based on these results, the approach for conventional placements for a full-scale project could be adjusted to incorporate some vessel speed over the target placement points to further reduce the energy and resulting resuspension.

Spreading placement methods. The spreading placement method, using multiple placements along a track line, was successful in constructing a uniform cap with an acceptable level of resuspension. However, the spreading placements did not result in a true “particle settling condition” as described in Palermo et al. (1999). Even though the spreading loads descended as a momentum-driven descent (jet) and exhibited a measurable bottom surge, the level of disturbance and resuspension of EA sediments was less than that of the conventional placement method.

Placement modeling. The STFATE and MDFATE models were important tools in management of the pilot study operations and aided in interpretation of the monitoring data. Application of the models will also be an important component in the development of a plan of operations for any full-scale capping projects. The pilot study efforts indicated the need for refinements to the models to increase their utility. For example, during this effort, STFATE was modified to allow for the ability to model the impact of vertical shear in the ambient current on suspended sediment plumes. However, model refinements to allow for time varying currents are still needed if the fate of suspended sediment plumes over several hours is desired. Possible refinements to MDFATE include expanded sediment transport algorithms, easier incorporation of current data into the model grids, refined spreading placement options, and incorporation of additional placement options such as subsurface discharge and hydraulic discharge.

Placement cells. Placement cells of 300 by 600 m proved useful in managing placement, modeling, and monitoring efforts. However, for full-scale cap construction, the size of the cells should probably be enlarged, perhaps to 500 m by 1,000 m or larger. If spreading placements are used, the length of the cell could be increased to the distance the dredge can travel during placement of a single, full load of dredged material.

Spacing and sequencing of placements. Monitoring results indicated the 75-m spacing for conventional placements, which were based on modeling and the results of the initial placement events, appeared to be reasonable for helping attain a uniform cap. Additional placements at the initial placement point prior to moving to the next point would help to reduce mixing and resuspension of EA sediments by extending the footprint and thickness of the cap around this initial point (e.g., to a thickness of 20-25 cm), such that subsequent placements have at least several centimeters of cap at the impact point. Thus, other than the first few placement events, all placement events should be shielded from directly impacting and disturbing the EA sediment resulting in even less mixing than observed in the pilot project. For a full-scale project, a placement sequence starting at the southeast end of the shelf and then working to the northwest may also minimize the potential for recontamination. A similar approach should also be used for spreading placements where more loads are placed on the first lane before moving to adjacent lanes.

Capping at the Whites Point outfalls. Pilot results showed that a thin cap thickness can be placed over a large area with both point and spreading methods and that a cap can be gradually built up without large clumps and irregular thicknesses. Pilot results also showed that placement locations can be controlled with enough precision to ensure that individual loads are not placed too close to the outfall pipes, that the spread of material can be reliably predicted in advance, and the placement and spreading process can be monitored during construction. This indicates that cap material could be placed in the vicinity of the outfalls without covering the outfall ports if appropriately managed and monitored.

Required cap volumes and construction times. The volumes of capping material required and construction times for each of several dredging options

were calculated in Palermo et al. (1999) using assumed values for losses due to overflow during dredging, losses outside the larger area to be capped due to far field cap material dispersion, volume change from in-source volume to in-place cap and estimates of placement cycle times and effective production efficiencies. The pilot study provided data that can be used to refine volume and construction time estimates.

5.2.3 Future Monitoring

Overall, the monitoring approach and techniques used for the pilot study were effective, and many of them should be retained as part of any full-scale project monitoring.

Based on knowledge gained in the pilot project, some monitoring tools would have limited use in a full-scale project. Side-scan sonar is likely to be useful only for assessing large-scale changes to seafloor topography, which were shown not to occur during the pilot. Bottom-deployed instruments for surge measurements would likely be only used to assess initial placement near the shelf break. Sub-bottom sediment profiling, while of limited use in the pilot project, should continue to be considered because it may be more useful when uniformly thicker caps are created in a full-scale project.

The effectiveness of coring techniques to measure cap thickness exceeding the detection range of SPI (approximately 10-12 cm) was reduced by coring artifacts. Even though gravity and vibracoring did help to assess cap thickness, these techniques were not as robust and reliable as expected. Evaluation of alternative coring approaches is on-going, and a recent box coring survey has been completed¹.

A monitoring plan for a full-scale project was outlined in Palermo et al. (1999). The following refinements and revisions should be considered based on the results of the pilot:

- a. Identify and field test improved coring methods to minimize coring artifacts and consider other innovative methods for improved measurement of cap thickness.
- b. Specify additional grain-size distribution ranges for analysis of core geotechnical data, and consider defining ranges corresponding to the Unified Soil Classification System instead of Phi system to allow for better interpretation of modeling results.
- c. Utilize more paired SPI and core stations for better interpretation of cap thickness and coverage.
- d. Reconfigure instrumentation for surge measurements for deeper water depths downslope of seaward cells.

¹ The supplemental box coring survey was completed in March 2002. Results of this survey will be included in a later report.

- e. Deploy downstream sediment traps to assess far field transport of suspended sediments.

5.3 Conclusions and Recommendations

5.3.1 Conclusions

Based on the results of the pilot study, the following conclusions are made:

- a. The construction of a cap to substantially isolate the contaminated sediments on the PV Shelf from the marine environment is an achievable objective.
- b. Both conventional placement using Queen's Gate sediments and spreading methods using borrow area sand proved successful in constructing the desired cap thickness.
- c. The numerical modeling simulations compared well to field data. These included comparisons of the distribution of cap material on the seafloor, comparisons of bottom surge speeds as a function of distance from the placement location, and comparisons of the size, transport, and dilution of the suspended sediment plume resulting from each placement operation.
- d. Evidence from the sediment profile imaging, coring, and side-scan surveys support a conclusion that creating a uniform cap over the EA sediments on the PV Shelf is possible. The caps that were created using both conventional and spreading placement generally varied in thickness by only a few centimeters.
- e. Sediment profile data indicated that physical disturbance to the EA sediment was limited to a few centimeters for initial placements of cap material, and disturbance was minimized during the pilot study by careful management (i.e., overlap) of successive cap placement points. In addition, the spreading placement approach resulted in even less disturbance to in-place sediments than conventional placement methods.
- f. Elevated suspended solids and contaminant concentrations in the water column following placement of a load of cap material showed a rapid return to background levels following each placement event. Plume tracking data indicated low potential for impacts to nearshore kelp beds.
- g. Contaminant (DDE) measurements in core samples indicate that a clean cap can be constructed. The process of cap placement resulted in a 3-4 cm layer of mixed cap and EA sediment. As cap thickness increased beyond this, mixing with the EA sediment became negligible such that the levels of contaminants in upper portions of the cap were near those in the cap material source area.

- h.* No evidence of cap or EA sediment instability with respect to avalanching or mudflows was observed as a result of operations. Current surge monitoring results indicated that the energy from conventional point cap placement decayed with distance and time away from the point of release. Surge velocities from spreading placements were much lower than for the conventional placements. No large-scale deformations or changes in the seafloor around the cells and in particular downslope were observed.
- i.* The pilot demonstrated that a cap can be adequately monitored. The monitoring equipment and techniques proved generally effective in obtaining the desired data, and were generally effective across the range of site conditions encountered during the field pilot study.
- j.* The pilot study results provided data on the ability to construct a cap and the effects of site conditions, material type, and placement methods on cap construction. These data will prove useful to decision makers regarding implementation of any future full-scale cap on the PV Shelf.

5.3.2 Recommendations for continued monitoring of pilot study cells

The pilot study caps now in place on the shelf provide an opportunity to collect data on long-term processes which could be applied in design and management of a future full-scale project. Some activities are already underway, i.e., supplemental coring survey and testing for erosion characteristics of cap sediments. The following activities should be considered:

- a.* Recolonization. Surveys of recolonization and bioturbation to include deep box cores to determine if deep bioturbators colonize the pilot study cap in significant numbers and if so, what are their depths of bioturbation.
- b.* Bioturbation. SPI surveys and core sample analysis to observe long-term changes in the depths of sediment mixing due to bioturbation.
- c.* Currents and erosion. A moored measurement program to assess the dynamic oceanographic/physical processes with the potential for erosion of cap material. Both EA and cap as placed sediment samples should be collected and tested (for more precise prediction of erosion rate characteristics).
- d.* Cap effectiveness. Core sample analysis to observe any long-term changes in sediment chemistry profiles.
- e.* Severe event monitoring. Multicomponent program following a major storm or seismic event.

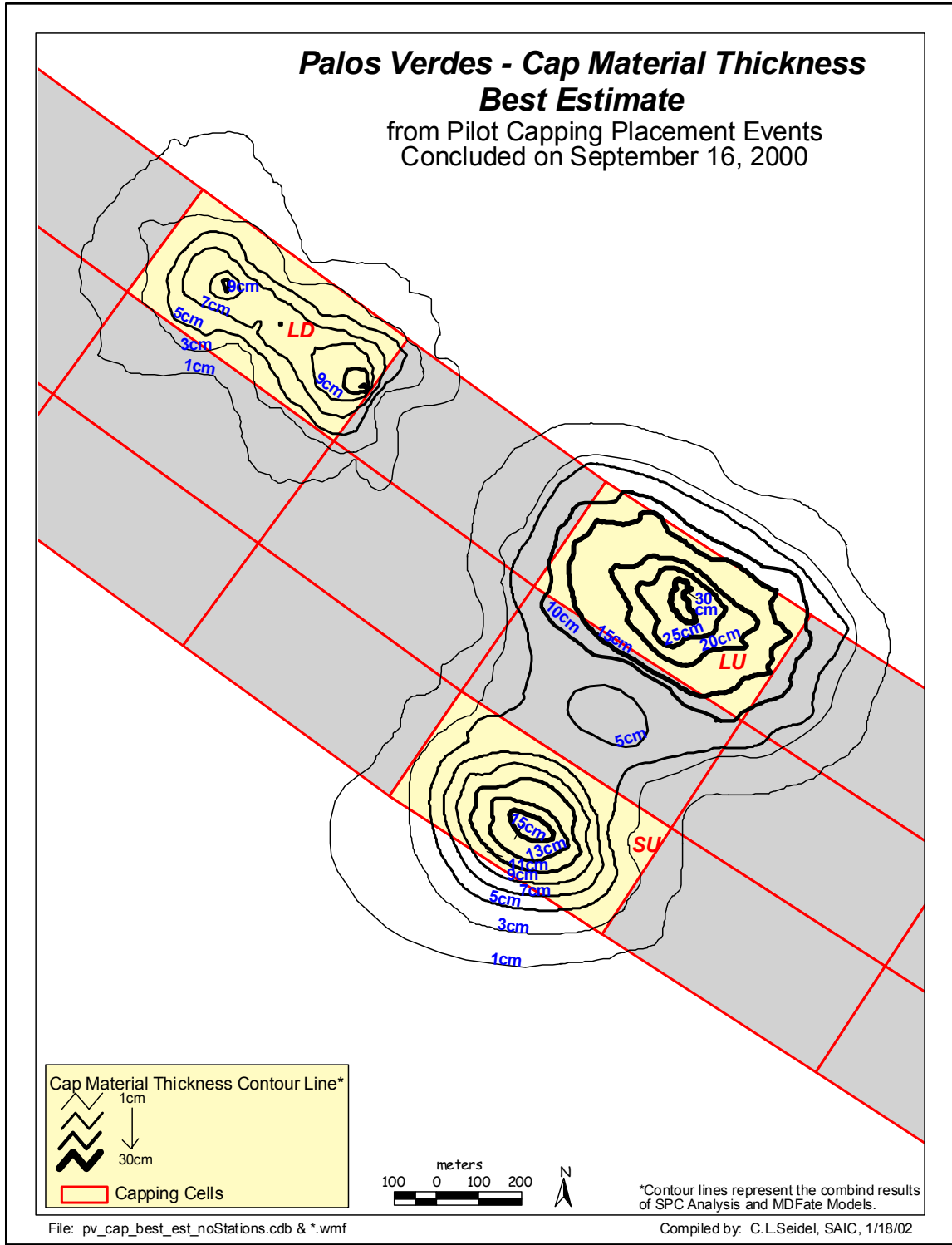

Figure 5-1. Estimate of total cap thickness as placed for the Palos Verdes pilot capping study

6 References

- Bokuniewicz, H. J., Gilbert, J., Gordon, R. B., Higgins, J. L., Kaminsky, P., Pilbeam, C. C., Reed, M., and Tuttle, C. (1978). "Field study of the mechanics of the placement of dredged material at open-water placement sites, Vol. 1: Main text and appendices A-I," Technical Report D-78-7, U.S. Army Engineer Waterways Experiment Station, Vicksburg, MS.
- Brandsma, M. G., and Divoky, D.J. (1976). "Development of models for prediction of short-term fate of dredged material discharged in the estuarine environment," Contract Report D-76-5, U.S. Army Engineer Waterways Experiment Station, Vicksburg, MS, prepared by Tetra Tech, Inc., Pasadena, CA.
- Chase, D. (1994). "Dropmix user's manual," draft report prepared for the Environmental Laboratory, U.S. Army Waterways Experiment Station, Vicksburg, MS.
- Clausner, J. E., Gailani, J., Bratos, S., Johnson, B., Schroeder, P., and Teeter, A. (2001). "Status of Corps dredged material fate models," *Proceedings of the Western Dredging Association XXI Technical Conference and 33rd Texas A&M Dredging Seminar*, Center for Dredging Studies, TAMU, College Station, TX.
- Doneker, R. L., Jirka, G. H., and Nash, J. D. (1995). "CD-CORMIX for continuous dredge disposal mixing zone analysis, Version 1.0," Final Draft Contract Report, EPA Contract No. 68-C3-0374, U.S. Environmental Protection Agency, Office of Science and Technology, Newport, OR.
- Fredette, T. J., Jackson, P. E., Demos, C. J., Hadden, D. A., Wolf, S. H., Nowak, T. A., Jr., and DeAngelo, E. (2000). "The Boston Harbor navigation improvement project CAD cells: Recommendations for future projects based on field experience and monitoring," *Proceedings of the Western Dredging Association*, Twentieth Technical Conference and Twenty-second Texas A&M Dredging Seminar, June 25-28, Warwick, RI. 291-302.
- Gailani, J.Z., Smith, S.J., Scheffner, N.W., and Vanadit-Ellis, W. (2001). "Dredged material fate modeling of proposed Providence River confined aquatic placement (CAD) cells and ocean dredged material placement site (ODMDS), Report prepared for USACE New England District (draft) by USACE Engineering Research and Development Center, Vicksburg, MS.
- Hales, L. (1995). "Accomplishments of the Corps of Engineers Dredging Research Program," *Journal of Coastal Research* 11(1), 66-88.

- Hampton, M. (1974). "Acoustic survey of the Palos Verdes Shelf and vicinity," Appendix A to Lee, H. J. (1994). "The distribution and character of contaminated effluent affected sediment, Palos Verdes Margin, Southern California," Expert Report, U.S. Geological Survey.
- Havis, R. N. (1994). "Mixing zone simulation model for dredge overflow and discharge into inland and coastal waters," U.S. Army Engineer Waterways Experiment Station, Vicksburg, MS.
- Johnson, B. H. (1990). "User's guide for models of dredged material placement in open water," Technical Report D-90-5, U.S. Army Engineer Waterways Experiment Station, Vicksburg, MS.
- _____. (2001). "Model upgrade allows improved simulation of bottom surges caused by open-water placement of dredged material," *Dredging Research*, 4(1), U.S. Army Engineer Research and Development Center.
- _____. (2001). "Model upgrade allows improved simulation of bottom surges caused by open-water placement of dredged material," *Dredging Research*, 4(1), U.S. Army Engineer Research and Development Center.
- Johnson, B. H., and Fong, M.T. (1993). "Development and verification of numerical models for predicting the initial fate of dredged material disposed in open water, Report 2: Theoretical developments and verification results," *Dredging Research Program Technical Report DRP-93-1*, U.S. Army Engineers Waterways Experiment Station, Vicksburg, MS.
- Johnson, B. H. and Fong, M. (1995). "Development and verification of numerical models for predicting the initial fate of dredged material disposed in open water, Report 2: Theoretical developments and verification," *Technical Report DRP-93-1*.
- Johnson, B. H., McComas, D. N., McVan, D. C., and Trawle, M. J. (1993). "Development and verification of numerical models for predicting the initial fate of dredged material disposed in open water, Report 1: Physical model tests of dredged material placement from a split-hull barge and a multiple bin vessel," *Technical Report DRP-93-1*, U.S. Army Engineer Waterways Experiment Station, Vicksburg, MS.
- Johnson, B. H., Andersen, E., Isaji, T., Teeter, A. M., and Clarke, D. G. (2000). "Description of the SSFATE numerical modeling system," *DOER Technical Notes Collection (ERDC TN-DOER-E10)*, U.S. Army Engineer Research and Development Center, Vicksburg, MS. www.wes.army.mil/el/dots/doer
- Koh, R. C. Y., and Chang, Y. C. (1973). "Mathematical model for barged ocean placement of wastes," *Technical Series EPA 660/2-73-029*, U.S. Environmental Protection Agency, Washington, DC.
- LACSD. (1995). "Annual report-Palos Verdes ocean monitoring," County Sanitation Districts of Los Angeles County, CA.
- _____. (1996). "Annual ocean water quality and bottom monitoring report for 1995," County Sanitation Districts of Los Angeles County, Los Angeles, CA.
- _____. (1998). "Palos Verdes ocean monitoring, 1998," Los Angeles County Sanitation Districts, CA.

- Lee, H. J. (1994). "The distribution and character of contaminated effluent-affected sediment, Palos Verdes Margin, Southern California," Expert Report prepared for National Oceanic and Atmospheric Administration and the U.S. Department of Justice.
- Lillycrop, L. S., and Clausner, J. E. (1998) "Numerical modeling of the 1997 capping project at the MDS site," *Proceedings XVth World Dredging Congress 1998*, CEDA, Las Vegas, 937-951.
- McDowell, S., Pace, S., Singer, J., and Hamilton, P. (2001). "Palos Verdes Shelf capping: Moored measurements of near bottom currents and turbidity during cap placement," *Proceedings, 21st Annual Meeting of the Western Dredging Association (WEDA XXI) and 33rd Annual Texas A&M Dredging Seminar*, Houston, TX.
- Moritz, H. R., and Randall, R. E. (1995). "Simulating dredged-material placement at open-water disposal sites," *Journal of Waterway, Port, Coastal, and Ocean Engineering*, ASCE, 121(1).
- Noble, M. (1994). "Circulation patterns over the Palos Verdes Shelf and upper slope," Appendix H to "Predictive modeling of the natural recovery of the contaminated effluent-affected sediment, Palos Verdes Margin, Southern California," Pacific Marine Geology Branch, United States Geological Survey.
- Palermo, M. R. (1994). "Feasibility study of sediment restoration alternatives for the Southern California natural resource damage assessment," Expert Report prepared for National Oceanic and Atmospheric Administration and the U.S. Department of Justice, U.S. Army Engineer Waterways Experiment Station, Vicksburg, MS.
- Palermo, M., Schroeder, P. R., Rivera, Y., Ruiz, C., Clarke, D., Gailani, J., Clausner, J., Hynes, M., Fredette, T., Tardy, B., Peyman-Dove, L., and Risko, A. (1999). "Options for in situ capping of Palos Verdes Shelf contaminated sediments," Technical Report EL-99-2, U.S. Army Engineer Waterways Experiment Station, Vicksburg, MS. (available on the Web at <http://www.wes.army.mil/el/elpubs/pdf/trel99-2.pdf>).
- Palermo, M. (2000). "Field pilot study of in situ capping of Palos Verdes Shelf contaminated sediments – Operations and Monitoring plan." (This document is included as Appendix A to this report.)
- SAIC. (2000a). "Project work plan for the Palos Verdes pilot capping project: Baseline Monitoring Activities – Quality Assurance Project Plan," Report Number 486D, Science Applications International Corporation, Newport, RI. (This document is included as Appendix D to this report.)
- SAIC. (2000b). "Project work plan for the Palos Verdes pilot capping project: Interim and post-cap monitoring activities - FIELD SAMPLING PLAN," Science Applications International Corporation, Newport, RI. (This document is included as Appendix D to this report.)
- SAIC. (2000c). "Palos Verdes pilot capping monitoring project cruise report," Report Number 510, Science Applications International Corporation, Newport, RI. (This document is included as Appendix H to this report.)

- SAIC. (2001). "Monitoring results from the field pilot study of in situ capping of Palos Verdes Shelf contaminated sediments," Science Applications International Corporation, Newport, RI. (This document is included as Appendices I and J to this report.)
- Scheffner, N. W., Thevenot, M. M., Tallent, J. R., and Mason, J. M. (1995). "LTFATE: A model to investigate the long-term fate and stability of dredged material placement sites; User's guide," Dredging Research Program Instruction Report DRP-95-1, U.S. Army Engineer Waterways Experiment Station, Vicksburg, MS.
- Truitt, C. L. (1986). "Fate of dredged material during open water disposal," Technical Note EEDP-01-2, U.S. Army Engineer Waterways Experiment Station, Vicksburg, MS.
- U.S. Army Corps of Engineers. (2000a). "Final supplemental environmental assessment for Palos Verdes Shelf capping demonstration project, Pacific Ocean, Palos Verdes, California," May. Los Angeles District, Los Angeles, CA.
- U.S. Army Corps of Engineers. (2000b). "Final supplemental environmental assessment for borrow site dredging and transportation, Palos Verdes Shelf capping demonstration project, Pacific Ocean, Palos Verdes, California," August. Los Angeles District, Los Angeles, CA.

REPORT DOCUMENTATION PAGE

Form Approved
OMB No. 0704-0188

Public reporting burden for this collection of information is estimated to average 1 hour per response, including the time for reviewing instructions, searching existing data sources, gathering and maintaining the data needed, and completing and reviewing this collection of information. Send comments regarding this burden estimate or any other aspect of this collection of information, including suggestions for reducing this burden to Department of Defense, Washington Headquarters Services, Directorate for Information Operations and Reports (0704-0188), 1215 Jefferson Davis Highway, Suite 1204, Arlington, VA 22202-4302. Respondents should be aware that notwithstanding any other provision of law, no person shall be subject to any penalty for failing to comply with a collection of information if it does not display a currently valid OMB control number. **PLEASE DO NOT RETURN YOUR FORM TO THE ABOVE ADDRESS.**

1. REPORT DATE (DD-MM-YYYY) September 2002			2. REPORT TYPE Final report			3. DATES COVERED (From - To)			
4. TITLE AND SUBTITLE Field Pilot Study of In Situ Capping of Palos Verdes Shelf Contaminated Sediments						5a. CONTRACT NUMBER			
						5b. GRANT NUMBER			
						5c. PROGRAM ELEMENT NUMBER			
6. AUTHOR(S) Thomas J. Fredette, James E. Clausner, Michael R. Palermo, Steven M. Bratos, Terry L. Prickett, Billy H. Johnson, Mamie S. Brouwer, Joseph A. Ryan, Lawrence J. Smith, Eleanor E. Nevarez, Fredrick K. Schaffler, and Scott McDowell						5d. PROJECT NUMBER			
						5e. TASK NUMBER			
						5f. WORK UNIT NUMBER			
7. PERFORMING ORGANIZATION NAME(S) AND ADDRESS(ES) See reverse.						8. PERFORMING ORGANIZATION REPORT NUMBER ERDC TR-02-5			
9. SPONSORING / MONITORING AGENCY NAME(S) AND ADDRESS(ES) U.S. Environmental Protection Agency 1200 Pennsylvania Avenue, NW Washington, DC 20460						10. SPONSOR/MONITOR'S ACRONYM(S)			
12. DISTRIBUTION / AVAILABILITY STATEMENT Approved for public release; distribution is unlimited.						11. SPONSOR/MONITOR'S REPORT NUMBER(S)			
13. SUPPLEMENTARY NOTES Appendices A-L will be posted separately from the main text and will be linked as activated.									
14. ABSTRACT Sediments covering approximately 40 sq km of the ocean floor at the Palos Verdes Shelf, near Los Angeles, CA, are contaminated with DDT and PCB. The U.S. Army Corps of Engineers (USACE), working in support of the U.S. Environmental Protection Agency (EPA), has conducted studies investigating the feasibility of in situ capping all or a portion of the site with a layer of clean sandy dredged material. A feasibility study was conducted to determine the feasibility and effectiveness of in-situ capping. This study included the necessary engineering and environmental analyses such as preliminary cap designs, operations plans, and monitoring and management plans for a range of in-situ capping options. The USACE has also recently completed a field pilot study at this site. The pilot study involved placement of approximately 103,000 cu m of capping sediments using a split-hull hopper dredge. Three 18-ha capping cells situated at water depths between 40 and 70 m were capped using both conventional placement methods and special spreading methods. A large-scale environmental monitoring effort was conducted before, during, and after cap placement using a number of state-of-the-art techniques and specialized equipment. Predictive modeling was also conducted during and following the placements to guide field operations and refine data for design purposes. This report provides a description of the project setting and conditions and summarizes the results of the feasibility and field pilot studies.									
15. SUBJECT TERMS Hopper dredge In situ capping			Sediment remediation Subsequent capping Superfund						
16. SECURITY CLASSIFICATION OF:				17. LIMITATION OF ABSTRACT		18. NUMBER OF PAGES		19a. NAME OF RESPONSIBLE PERSON	
a. REPORT UNCLASSIFIED	b. ABSTRACT UNCLASSIFIED	c. THIS PAGE UNCLASSIFIED			246		19b. TELEPHONE NUMBER (include area code)		

7. (Concluded).

U.S. Army Engineer District, New England
696 Virginia Road, Concord, MA 01742-2751;
Coastal and Hydraulics Laboratory, and Environmental Laboratory
3909 Halls Ferry Road, Vicksburg, MS 39180-6199;
Computational Hydraulics and Transport, LLC
300 Front Street, Edwards, MS 39066;
U.S. Army Engineer District, Seattle
P.O. Box 3755, Seattle, WA 98124-3755;
U.S. Army Engineer District, Los Angeles
911 Wilshire Blvd., Los Angeles, CA 90017;
Region 9, U.S. Environmental Protection Agency
Superfund Division (SFD-7-1)
75 Hawthorn Street, San Francisco, CA 94105;
Science Applications International Corporation
Admiral's Gate
221 Third Street, Newport, RI 02840