

US EPA ARCHIVE DOCUMENT

Romic Environmental Technologies Corp.

AZD 009015389

Chandler, Arizona

TSD Facility

Section E

Process Operations

January 2005

SECTION E PROCESS OPERATIONS

TABLE OF CONTENTS

E	PROCESS OPERATIONS	E-1
E1	DISTILLATION (FRACTIONATION) COLUMN 30	E-1
E1.1	PROCESS OVERVIEW	E-1
E1.2	REBOILER (R30).....	E-4
E1.3	SEPARATOR.....	E-6
E1.4	OTHER COMPONENTS	E-7
E2	VACUUM POT.....	E-8
E2.1	PROCESS OVERVIEW	E-8
E2.2	VACUUM POT.....	E-10
E2.3	TANKS S-1 AND S-2.....	E-12
E2.4	OTHER COMPONENTS	E-13
E3	THIN FILM EVAPORATOR.....	E-14
E3.1	PROCESS OVERVIEW	E-14
E3.2	RECEIVER TANK AND FLUSH TANK	E-17
E3.3	TANK 105.....	E-18
E3.4	OTHER COMPONENTS	E-21
E4	ACID-BASE NEUTRALIZATION	E-21
E4.1	TANK SYSTEMS DESCRIPTION	E-21
E4.2	NEW TANK STANDARDS.....	E-22
E4.3	CONTAINMENT AND DETECTION OF RELEASES	E-22
E4.4	CONTROLS AND PRACTICES TO PREVENT SPILLS AND OVERFLOWS	E-23
E4.5	AIR EMISSION CONTROLS.....	E-23
E5	FUEL BLENDING.....	E-24
E5.1	PROCESS OVERVIEW	E-24
E5.2	TANK 105.....	E-25
E5.3	PLANNED TANKS 137 AND 138.....	E-25
E6	AEROSOL DEPRESSURIZATION	E-26
E6.1	PROCESS OVERVIEW	E-27
E7	OTHER PROCESSES	E-29
E7.1	WASTEWATER TREATMENT	E-29
E7.2	DRUM CRUSHING	E-29
E7.3	GLASS STILL	E-29
E7.4	DEBRIS DECONTAMINATION.....	E-29
E7.5	TANKER WASHOUT	E-30

SECTION E PROCESS OPERATIONS

TABLE OF CONTENTS

Tables

Table E-1	Process Tanks
Table E-2	Process Tank Secondary Containment

Figures

Figure E-1	Key to Symbols Used
Figure E-2	Vac Pot-Thin Filmer-Distillation Column Area Layout Diagram
Figure E-3	Distillation Column Process Flow Diagram
Figure E-4	Vacuum Pot Process Flow Diagram
Figure E-5	Thin Film Evaporator Process Flow Diagram
Figure E-6	Tank Farm G Layout Diagram
Figure E-7	Tank Farm G Process Flow Diagram
Figure E-8	Aerosol Can Unit
Figure E-9	Aerosol Depressurization System

Appendix

Appendix E-1	JWI Filter Press Information
--------------	------------------------------

E PROCESS OPERATIONS

This section contains information on the hazardous waste treatment processes, current and proposed, at the Romic Southwest facility. These treatment processes may be used for nonhazardous as well as hazardous wastes. Each subsection provides an overview of a regulated process, its associated equipment, and the controls applicable to the process.

Figure E-1, Key to Symbols, is a key to the symbols used in the piping and instrument diagrams (P&IDs) included in this section. Table E-1, Process Tanks, lists the tanks and tank-like equipment that are components of the treatment process units. Table E-2, Process Tank Secondary Containment, provides secondary containment calculations for the areas in which process units are located.

E1 DISTILLATION (FRACTIONATION) COLUMN 30

E1.1 PROCESS OVERVIEW

Fractionation is a multi-stage separation process that has been used for over forty years at Romic facilities. It is also a commonly used technology in the chemical processing and petroleum refining industries to recover products from a mixture or increase the purity of a particular product. This section describes the fractionation process.

The Romic distillation column process unit is located immediately south of the vacuum pot-thin filmer area, just south of Tank Farm A on the west side of the facility (see Figure D-1, Facility Layout). A layout diagram of the combined Vacuum Pot-Thin Filmer-Distillation Column area is provided as Figure E-2, Vacpot Thinfilmer Column Area. A P&I diagram illustrating the distillation column process is included as Figure E-3, Column 30 Process Flow Diagram.

The fractionation distillation unit consists of the distillation column, a reboiler, a heat exchanger for heating liquid in the reboiler, a circulation pump, a condenser, a receiver, two plate and frame condensers in series, a product pump, a reflux pump, and a vacuum pump. The maximum operating temperature of the unit is about 340°F. The unit may be operated under vacuum to reduce the boiling point of high boiling liquids and achieve the desired separation more efficiently. Average operating temperatures are about 220°F, and vary with the boiling points of the liquids being processed.

The process begins with the transfer of a waste liquid into the reboiler. The liquid is heated by pumping it through the tube side of an external shell and tube heat exchanger that uses steam as a heating medium. As the mixture heats, the lower boiling point components (also known as the lighter fractions) tend to concentrate in the vapor phase. When the liquid reaches the desired temperature, the vapors are then fed into the fractionation column. Columns are designed to allow liquid-vapor contact throughout the length of the column. As the vapors rise in the column, they condense on horizontal sieve trays configured so there is always some liquid on each tray. Vapors rising from a tray contact and pass through the liquid on next tray above, where they either condense or continue upward travel. The composition of the liquid and the vapor at any given point in a column depends upon the temperature at that point. The temperature is

higher at the bottom of the column, and lower at the top. The concentration of the lighter, lower boiling temperature compounds is higher at the top of the column, while the heavier, high boiling temperature components concentrate in the lower portions of the column and in the reboiler. A larger number of trays allows for increased separation (less heavy compounds in the light overhead product and less light ends in the heavy bottoms).

The vapors that exit the top of the column are condensed in a water-cooled shell and tube heat exchanger (condenser) with the cooling water on the tube side and the product in the shell. After the condenser, the product is sent to distillate receiver vessel (separator) where the liquid is separated from non-condensable gases. The non-condensable gases are inert gases or chemicals that have a boiling point less than the cooling water temperature. The non-condensed gases are directed through a set of plate and frame heat exchangers that use a chilling system to condense lower boiling point vapors into liquids. If there are any non-condensable gases left after the heat exchanger, they are directed to the closed vent system through the vacuum pump, and on to the process vent. A portion of the condensed liquid from the separator is fed back to the top of the column as reflux. During startup, all condensed material may be routed back to the column. This is known as total reflux and helps to establish the proper conditions in the fractionation column to recover the target solvents. The reflux liquid travels downward through the column. As this liquid travels down the column, the heavier constituents increase in concentration as the lighter ones evaporate. The liquid at the bottom of the column flows back into the reboiler, where it can be revaporized.

The fractionation column may produce product from the top of the column (overhead) and/or the column bottom or reboiler (bottoms). This depends on whether the waste mixture is contaminated with heavy, less volatile constituents (product recovery at the top of the column) or the waste mixture is contaminated with light, less volatile constituents (product recovery at the bottom). Depending on the waste, products may be recovered both at the top and the bottom of the fractionation column. Multiple products may also be recovered on the top as the temperature changes.

If a product is recovered from the overhead, samples of the distillate from the top of the fractionation column are collected to determine the disposition. When the column conditions generate the target product, the distillate stream from the separator will be diverted to a product or storage tank(s). Frequently, the initial liquid that condenses is a lighter solvent than the desired product and will be sent to a tank other than the desired product tank. If the overhead stream is not the desired product, it will be sent to a tank for further processing, reuse, or for blending as a fuel.

A sample will be collected from the product storage tank for analysis to determine if the batch of product meets customer specifications. These specifications vary considerably based on the customer's use of the material. If the product does not meet specification, it may be processed further, or purchased high-purity solvent may be added to elevate the concentration to meet required product purity, quantity, or other specifications. If the product is solvent meeting customer specifications, it is either packaged into containers such as 55-gallon drums or totes, or shipped in bulk tankers to customers.

E1.1.1 Waste Characterization

40 CFR 264.601(a)(1),(b)(1),(c)(1); 270.23

Halogenated and non-halogenated solvents, organics-containing wastewaters and ethylene glycol waste streams may be processed by fractionation. Typical RCRA waste codes to be managed in this unit include but are not limited to F001, F002, F003, F004, F005, and D001. See Section C, Tables C-1 for a more complete list of the RCRA Codes that may be processed in this unit. For optimum separation in the fractionation process, waste streams should contain higher concentrations of target liquid products, usually 75% or greater. Generally, fractionation is used to recover liquids where a high purity is required for the end product, or the liquid contains multiple components that may be recovered, or for mixtures that are more difficult to separate.

Waste that will be fractionated must have a low solids content to avoid fouling the contact trays in the fractionation column. If a waste to be fractionated contains a significant amount of solids, the waste may be first processed by thin film evaporation to remove the solids prior to fractionation.

Reactive and incompatible wastes are not processed in this unit. The fractionation unit is designated to process organic solvents and wastewaters containing organics, and is constructed of stainless steel. Refer to Section C for information on how compatibility is determined. The entire system is steamed out between runs of different materials to avoid cross contamination of product. Process residues and condensed cleaning steam may be drained into drums (90-day storage) at designated points in the system. Some of the organic solvents may be classified as ignitable wastes. To accommodate these, the fractionation unit is more than 15 feet from public ways or a property line that can be built upon, is properly grounded, and is connected to the plant closed-vent system.

This unit has a nominal processing rate of 850 gallons per hour. Processing rates will vary depending upon the waste being processed, the target product, and the desired product purity. Current normal processing rate through the fractionation column is about 65,000 gallons per month. With low boiling solvents and operating under a vacuum, the fractionation unit can produce up to 331,200 gallons per month.

E1.1.2 Potential for Releases

40 CFR 264.601, 270.23(b),(c),(e)

The fractionation column system has one vent from the separator, which is vented via the vacuum pump to a process vent. There are no pressure relief devices on the fractionation column or any of the system components. Process vent emissions are regulated under Subpart AA and are directed to a VOC reduction unit, described in Section M, if they exceed the exemption thresholds.(40 CFR 264.1080(b)(8)) It is likely that the fractionation unit will be exempt from the Subpart AA standards due to its operation below the maximum allowed emissions limits. Calculations to support this exemption are located in Appendix M-2. The potential for release to groundwater and soil is mitigated by adherence to tank standards (Subpart J) for containment of the tank-like equipment within the system (see Sections E1.2-E1.3 below)

and by locating the entire system in a secondary containment structure that conforms to Subpart J standards.

E1.1.3 Air Emission Controls

The fractionation distillation unit will be permitted as a miscellaneous 40 CFR 264 Subpart X unit, with some tank-like units and associated ancillary equipment. There are no pressure relief devices anywhere in this unit. All of the fractionation unit components are connected in series to a closed vent system which conveys any residual organic vapors to a process vent. Appendix M-2 provides calculations to verify that the unit does not exceed the emissions threshold of less than 1.4 kg/h (3 lb/h) or 2.8 kg/yr (3.1 tons/yr) under “worst case” conditions and is therefore exempted by 40 CFR 264.1032(a)(1). In the event that production increases emissions to or above the the exemption thresholds, a VOC reduction unit regulated under 40 CFR 264 Subpart AA may be put into service on the process vent. Since all of the tank-like components of the fractionation unit are indirectly vented (by venting through each other in series) to the process vent through the vacuum pump, with no vents anywhere else in the unit, 40 CFR 264 Subpart CC standards do not apply to these tank-like components (40 CFR 264.1080(b)(8)).

The fractionation unit may be subject to 40 CFR 264 Subpart BB standards if the unit processes hazardous waste 300 or more hours per year in non-vacuum service. 40 CFR 264.1050(e) exempts equipment in vacuum service and 264.1050(f) exempts equipment operated less than 300 hours per year in hazardous waste service from Subpart BB standards. The fractionation unit is used for processing significantly more non-hazardous waste than hazardous waste throughout the year, and is usually operated under vacuum. Refer to Section N for a discussion of Subpart BB standards. Romic does not intend to limit the types of waste processed in the fractionation unit, but the current economic trend is toward more non-hazardous rather than hazardous waste processing. Process logs will be used to document whether or not the Subpart BB exemptions apply.

E1.1.4 Closure

At closure, all hazardous waste remaining in the fractionation unit will be treated onsite or shipped offsite for treatment and/or disposal, and all hazardous waste residues will be removed from the unit components, piping and containment system. Section J provides the Closure Plan for the entire facility. Section J1.8.1 discusses inventory elimination, and Section J1.8.2 discusses decontamination procedures for closure purposes.

E1.2 REBOILER (R30)

E1.2.1 Tank System Description

40 CFR 270.14(b)(1); 270.16(b); 264.194(b); 264.196; 264.199

The reboiler is an aboveground tank located adjacent to the distillation column within the distillation column building. Information on the reboiler (also referred to as “R30”) is given in Table E-1. Ancillary equipment within this system is described in Section E1.4 below.

E1.2.2 Tank Standards

40 CFR 264.192; 270.16(a), (e), (f); 264.192(a)-(e)

Romic's process tanks were assessed by an independent, qualified, registered professional engineer. The certified assessment is included in this application as Section P.

E1.2.3 Containment and Detection of Releases

40 CFR 270.16(g); 264.193

The reboiler, along with most of the distillation column system, is located within a building with an impermeable concrete floor. Part of the fractionation system extends through the roof, but the entire system has secondary containment through an impermeable base of concrete with curbs surrounding the base. The containment slab is constructed of a minimum 6" 3000 lb concrete with #5 rebar 12" on-center each way. The concrete walls are tied to the base slab with reinforced steel using #5 rebar 12" on-center. All cold joints are joined using PVC or stainless steel water stops. All hazardous waste management areas are underlain by a 30 mil HDPE liner. The concrete is sealed with a chemical-resistant epoxy coating. The floor is sloped to a low point at a blind sump from which any spills or leaks draining away from equipment may be manually pumped.

The combined distillation column/ vacuum pot/ thin filmer area is surrounded by an eleven-inch high curb or wall. The opening in the wall between the distillation column area and the vacuum pot/ thin filmer area is five inches high at its lowest point. Thus, these areas combine to provide secondary containment capacity for all three systems. As demonstrated in Table E-2, the area provides adequate secondary containment capacity for all of the equipment in the combined area.

Any accumulated liquids in the containment area would be quickly observed via the tank and containment inspection procedures described in Section F and by the regular presence of facility operators in the vicinity. Process unit and containment basin inspections are described in Section F2.1, inspection schedules are found in Table F-1, and the inspection logs are found in Appendix F-1.

E1.2.4 Controls and Practices to Prevent Spills and Overflows

40 CFR 270.16(i); 264.194(a),(b); 264.195

The reboiler is equipped with high and high high level sensors that trigger an audible alarm to prevent overfills. Operators maintain an awareness of available capacity and intended transfer amount when charging the reboiler. Reboiler levels are recorded in the production logs.

The containment area is operated so that liquids from leaks or spills are localized and removed as soon as possible but within required regulatory time limits. Any spilled liquids, incident precipitation, or other liquids will be removed within 24 hours, or sooner if necessary to prevent overflow of the containment system. To minimize the occurrence of leaks or spills, the tanks and transfer operations are inspected regularly per the inspection schedule in Section F. Most releases are expected to be minor and could be cleaned up with dry absorbent materials and/or other material depending on the nature of the release. Large releases of hazardous waste would be handled as described in the Contingency Plan, Section G of

this application. It is expected that the hazardous waste materials released would be pumped to a tank in sound condition, that has available capacity, and if not empty, it contains a material of similar characteristics. The waste may be pumped directly or the material will be picked up by a vacuum tanker and then deposited into an appropriate tank.

Rainwater accumulations in the process containment area will be visually inspected. If there are indications (e.g., a sheen) that the rain water has contacted waste material, the source will be investigated and corrective measures implemented as warranted. All storm water that accumulates in process area secondary containment is transferred directly by pump or use of a vacuum tanker to a non-hazardous waste tank. Unless contaminated by significant waste materials, this is not a regulated activity and is included for general informational purposes.

E1.2.5 Air Emission Controls

40 CFR 264.200; 270.16(k); 270.24; 270.27

The reboiler is an integral part of the fractionation unit and vents through the column and other unit components to a process vent meeting the definition of 40 CFR 264.1031. Thus, it is not subject to the standards of Subpart CC per 264.1080(b)(8).

E1.3 SEPARATOR

E1.3.1 Tank System Description

40 CFR 270.14(b)(1); 270.16(b); 264.194(b); 264.196; 264.199

The separator is an aboveground stainless steel vessel, 75 gallons in capacity, located adjacent to the distillation column within the distillation column building. Additional details regarding the separator are contained in Table E-1. The separator is fed directly from the condenser (see Section E1.4.3 below). It is piped to the reflux pump to allow for product return to the column as reflux, and to the product pump to allow for transfer of product to a storage tank.

E1.3.2 Tank Standards

40 CFR 264.192; 270.16(a), (e), (f); 264.192(a)-(e)

Romic's tanks were assessed by an independent, qualified, registered professional engineer. The certified assessment is included in this application as Section P.

E1.3.3 Containment and Detection of Releases

40 CFR 270.16(g); 264.193

The separator is located within the same secondary containment structure as the reboiler. See Section E1.2.3 above for a description of process area secondary containment. Any accumulated liquids in the containment area would be quickly observed via the tank and containment inspection procedures described in Section F and by the regular presence of facility operators in the vicinity. Process unit and

containment basin inspections are described in Section F2.1, inspection schedules are found in Table F-1, and the inspection logs are found in Appendix F-1.

E1.3.4 Controls and Practices to Prevent Spills and Overflows

40 CFR 270.16(i); 264.194(a),(b); 264.195

The separator is equipped with a level transmitter and is controlled by the programmable logic controller (PLC) that controls the entire distillation column system. An overflow of the separator would not result in a release to the secondary containment structure; liquid would back up into the process unit piping.

The containment area is operated so that liquids from leaks or spills are localized and removed as soon as possible but within required regulatory time limits. Any spilled liquids, incident precipitation, or other liquids will be removed within 24 hours, or sooner if necessary to prevent overflow of the containment system. To minimize the occurrence of leaks or spills, the tanks and transfer operations are inspected regularly per the inspection schedule in Section F. Most releases are expected to be minor and could be cleaned up with dry absorbent materials and/or other material depending on the nature of the release. Large releases of hazardous waste would be handled as described in the Contingency Plan, Section B of this application. It is expected that the hazardous waste materials released would be pumped to a tank in sound condition, that has available capacity, and if not empty, contains a material of similar characteristics. The waste may be pumped directly or the material will be picked up by a vacuum tanker and then deposited into an appropriate tank.

Rainwater accumulations in the containment area will be visually inspected. If there are indications (e.g., a sheen) that the rain water has contacted waste material, the source will be investigated and corrective measures implemented as warranted. All storm water that accumulates in secondary containment areas is transferred directly by pump or indirectly by a vacuum tanker to a non-hazardous waste tank. Unless contaminated by significant waste materials, this is not a regulated activity and is included for general informational purposes.

E1.3.5 Air Emission Controls

40 CFR 264.200; 270.16(k); 270.24; 270.27

The separator is an integral part of the fractionation unit and vents via a vacuum pump to a process vent meeting the definition of 40 CFR 264.1031. Thus, it is not subject to the standards of Subpart CC per 264.1080(b)(8).

E1.4 OTHER COMPONENTS

E1.4.1 Column

The distillation column is an upright stainless steel cylinder fitted with horizontal sieve trays equipped with weirs. The column is operated at a controlled pressure (including partial vacuum) and temperature to separate one or more chemical constituents based on their relative vapor pressures at the process pressure and temperature. Romac's column is equipped with 20 horizontal sieve trays to allow vapor to go up the

column and liquid to travel down the column, with intimate contact between the liquid layer on each tray and vapor. This produces separation of lower boiling components (higher vapor pressure) to the vapor phase and higher boiling point (lower vapor pressure) constituents to the liquid phase. The fractionation column is designed to allow heated vapor to enter the column from the reboiler, and liquids to flow from the bottom back to the reboiler; overhead vapors are routed to a heat exchanger/condenser where the vapors are condensed to a liquid.

E1.4.2 Heat Exchanger

The fractionation unit is equipped with a noncontact external shell and tube heat exchanger to heat the material in the reboiler to a maximum of 340°F with steam on the shell side. The waste in the reboiler is pumped through the tube side of the heat exchanger and back into the reboiler to maintain the desired operating temperature. The condensed steam is returned to the boiler and circulates again as steam.

E1.4.3 Condensers

The fractionation unit is equipped with a noncontact external shell and tube heat exchanger that removes heat from the overhead vapor stream to condense it into a liquid. The condenser is cooled with water from the cooling towers on the tube side.

Two plate and frame heat exchangers (condensers) further reduce vapor temperature at the separator, enhancing product recovery and reducing product loss to the process vent. One noncontact plate and frame heat exchanger is cooled with cooling water, and the other noncontact plate and frame heat exchanger is cooled with an ethylene glycol-water solution from a chiller unit.

E2 VACUUM POT

E2.1 PROCESS OVERVIEW

The vacuum pot is a device that functions similarly to one tray of a fractionation column. As a waste mixture is heated to various temperatures and maintained at a controlled level of vacuum, the lighter component (more volatile) will preferentially partition into the vapor phase. The vapor phase is then condensed to recover liquid product. The product(s) recovered will vary with initial starting composition and operating temperature and pressure. Product may also be recovered as the material remaining in the vacuum pot after more volatile contaminants are driven off.

The vacuum pot unit is located in the vac pot/ thin filmer area just south of Tank Farm A (see Figure D-1). A layout diagram of the area is included as Figure E-2, Vacpot Thinfilmer Column Area. A piping and instrumentation diagram (P&ID) depicting the vacuum pot process is included as Figure E-4, Vacuum Pot Process Flow Diagram.

The vacuum pot unit consists of the vacuum pot, a heat exchanger for heating liquid in the vacuum pot, a circulation pump, a condenser, three separators, one plate and frame condenser, a product pump, and a vacuum pump. The maximum operating temperature of the unit is about 340°F. The unit may be operated under vacuum to reduce the boiling point of high boiling liquids and achieve the desired separation more efficiently. Average operating temperatures are about 220°F, and vary with the boiling points of the liquids being processed.

E2.1.1 Waste Characterization

40 CFR 264.601(a)(1),(b)(1),(c)(1); 270.23

Vacuum pot distillation can process material with high solids, oil, grease, water, and other contamination. Halogenated and non-halogenated solvents, organics-containing wastewaters, and ethylene glycol waste streams may be processed by vacuum pot distillation. Typical RCRA waste codes to be managed in this unit include but are not limited to F001, F002, F003, F004, F005, and D001. See Section C, Table C-1 for a more complete list of the RCRA Waste Codes that may be processed in this unit.

Reactive and incompatible wastes are not processed in this unit. The vacuum pot unit is designated to process organic solvents and wastewaters containing organics, and is constructed of stainless steel. Refer to Section C for information on how compatibility is determined. The entire system is steamed out between runs of different materials to avoid cross contamination of product. Process residues and condensed cleaning steam may be drained into drums (90-day storage) at designated points in the system. Some of the organic solvents may be classified as ignitable wastes. To accommodate these, the vacuum pot unit is more than 15 feet from public ways or a property line that can be built upon, is properly grounded, and is connected to the plant closed-vent system.

This unit has a nominal processing rate of 900 gallons per hour. Processing rates will vary depending upon the waste being processed, the target product, and the desired product purity. Current normal processing rate through the vacuum pot is about 65,000 gallons per month. With low boiling solvents and operating under a vacuum, the vacuum pot unit can produce up to 331,200 gallons per month.

E2.1.2 Potential for Releases

40 CFR 264.601, 270.23(b),(c),(e)

The vacuum pot system has one vent from the third separator, which is vented via the vacuum pump to a process vent. There is one Subpart BB-regulated pressure relief device on the vacuum pot itself, but there are no others on any of the other unit components. Process vent emissions are regulated under Subpart AA and are directed to a VOC reduction unit, described in Section M, if they exceed the exemption thresholds.(40 CFR 264.1080(b)(8)) It is likely that the vacuum pot unit will be exempt from the Subpart AA standards due to its operation below the maximum allowed emissions limits. Calculations to support this exemption are located in Appendix M-2. The potential for release to groundwater and soil is mitigated by adherence to tank standards (Subpart J) for containment of the tank-like equipment within the unit (see Sections E1.2-E1.3 below) and by locating the entire unit in a secondary containment structure that conforms to Subpart J standards.

E2.1.3 Air Emission Controls

The vacuum pot unit will be permitted as a miscellaneous 40 CFR 264 Subpart X unit, with some tank-like units and associated ancillary equipment. There is one pressure relief device, located on the vacuum pot itself. All of the vacuum pot unit components are connected in series to a closed vent system which conveys any residual organic vapors to a process vent. Appendix M-2 provides calculations to verify that the unit does not exceed the emissions threshold of less than 1.4 kg/h (3 lb/h) or 2.8 kg/yr (3.1 tons/yr) under “worst case” conditions and is therefore exempted by 40 CFR 264.1032(a)(1). In the event that production increases emissions to or above the the exemption thresholds, a VOC reduction unit regulated under 40 CFR 264 Subpart AA may be put into service on the process vent. Since all of the tank-like components of the vacuum pot unit are indirectly vented (by venting through each other in series) to the process vent through the vacuum pump, with no vents anywhere else in the unit, 40 CFR 264 Subpart CC standards do not apply to these tank-like components. (40 CFR 264.1080(b)(8))

The vacuum pot unit may be subject to 40 CFR 264 Subpart BB standards if the unit processes hazardous waste 300 or more hours per year in non-vacuum service. 40 CFR 264.1050(e) exempts equipment in vacuum service and 264.1050(f) exempts equipment operated less than 300 hours per year in hazardous waste service from Subpart BB standards. The vacuum pot unit is used for processing significantly more non-hazardous waste than hazardous waste throughout the year, and is usually operated under vacuum. Refer to Section N for a discussion of Subpart BB standards. Romac does not intend to limit the types of waste processed in the vacuum pot unit, but the current economic trend is toward more non-hazardous rather than hazardous waste processing. Process logs will be used to document whether or not the Subpart BB exemptions apply.

E2.1.4 Closure

At closure, all hazardous waste remaining in the vacuum pot unit will be treated onsite or shipped offsite for treatment and/or disposal, and all hazardous waste residues will be removed from the unit components, piping and containment system. Section J provides the Closure Plan for the entire facility. Section J1.8.1 discusses inventory elimination, and Section J1.8.2 discusses decontamination procedures for closure purposes.

E2.2 VACUUM POT

E2.2.1 Tank System Description

40 CFR 270.14(b)(1); 270.16(b); 264.194(b); 264.196; 264.199

The vacuum pot is an aboveground dished vessel. Information on the vacuum pot is included in Table E-1. The unit is located in the vac pot-thin filmer area, which is between the distillation column building and Tank Farm A. The vacuum pot is equipped with internal heating coils and an external heat exchanger (see E2.4 below).

E2.2.2 Tank Standards

40 CFR 264.192; 270.16(a), (e), (f); 264.192(a)-(e)

Romic's tanks were assessed by an independent, qualified, registered professional engineer. The certified assessment is included in this application as Section P.

E2.2.3 Containment and Detection of Releases

40 CFR 270.16(g); 264.193

The vacuum pot system is located within a roofed area with an impermeable concrete floor. All unit components are within the secondary containment area. The floor is constructed of 10" thick minimum 3000 lb concrete with #5 rebar 12" on-center each way. All hazardous waste management areas are underlain by a 30 mil HDPE liner. The concrete is sealed with a chemical-resistant epoxy coating. The floor is sloped to a low point at a blind sump from which any spills or leaks draining away from equipment may be manually pumped.

The combined distillation column-vacuum pot/thin film area is surrounded by walls and 11-inch high curbs where there are no walls. The wall opening between the distillation column area and the vacuum pot/thin film area is fitted with a five inch high curb. Thus, these areas combine to provide adequate secondary containment capacity for all three units, as demonstrated in Table E-2.

Any accumulated liquids in the secondary containment area would be quickly observed via the tank and containment inspection procedures described in Section F and by the regular presence of facility operators in the vicinity. Process unit and containment basin inspections are described in Section F2.1, inspection schedules are found in Table F-1, and the inspection logs are found in Appendix F-1.

E2.2.4 Controls And Practices To Prevent Spills And Overflows

40 CFR 270.16(i); 264.194(a),(b); 264.195

Overfill of the vacuum pot is prevented through manual verification of feed tank and vacuum pot levels, operator knowledge of the amount of waste to be transferred to the unit, and operator vigilance during transfers into the unit. In the unlikely event of an overfill, liquid would remain contained in the vacuum pot overhead vapor piping, the condenser, and subsequently into vessels S-1 and S-2 (see Section E2.3 below). There are no vents on the vacuum pot that could release liquid to the secondary containment area.

The containment area is operated so that liquids from leaks or spills are localized and removed as soon as possible but within required regulatory time limits. Any spilled liquids, incident precipitation, or other liquids will be removed within 24 hours, or sooner if necessary to prevent overflow of the containment system. To minimize the occurrence of leaks or spills, the tanks and transfer operations are inspected daily per the inspection schedule in Section F. Most releases are minor, associated with equipment leaks, and are cleaned up with dry absorbent and/or other material depending on the nature of the release. Releases of hazardous waste are handled as described in the applicable sections of the Contingency Plan, found in Section G. It is expected that pumpable releases of hazardous waste are directed to a tank in sound condition, with available capacity, and if not empty, it contains a material of similar characteristics.

The waste is either pumped directly, or picked up by a vacuum tanker and then deposited into an appropriate tank.

Rainwater accumulations in the secondary containment area will be visually inspected. If there are indications (e.g., a sheen) that the rain water has contacted waste material, the source will be investigated and corrective measures implemented as warranted. All storm water that accumulates in process secondary containment areas is transferred directly by pump or indirectly by use of a vacuum tanker to a non-hazardous waste tank. Unless contaminated by significant waste materials, this is not a regulated activity and is included for general informational purposes.

E2.2.5 Air Emission Controls

40 CFR 264.200; 270.16(k); 270.24; 270.27

The vacuum pot is an integral part of the vacuum pot unit and vents via a vacuum pump to a process vent meeting the definition of 40 CFR 264.1031. Thus, it is not subject to the standards of Subpart CC per 264.1080(b)(8). There is a pressure relief device on the vacuum pot that may be subject to Subpart BB standards if the vacuum pot is operated 300 or more hours per year in hazardous waste service. Subpart BB standards are discussed in Section N.

E2.3 TANKS S-1 AND S-2

E2.3.1 Tank System Description

40 CFR 270.14(b)(1); 270.16(b); 264.194(b); 264.196; 264.199

Separation tanks S-1 and S-2 are identical dished bottom, stainless steel receiving vessels that are an integral part of the vacuum pot unit. Additional information regarding these vessels is provided in Table E-1. Liquids condensed from the product vapor stream by the condenser are gravity-fed into S-1 and/or S-2. Liquids are transferred from S-1 and S-2 to product storage tanks via valved nozzles at the tank bottoms.

E2.3.2 Tank Standards

40 CFR 264.192; 270.16(a), (e), (f); 264.192(a)-(e)

Romic's tanks were assessed by an independent, qualified, registered professional engineer. The certified assessment is included in this application as Section P.

E2.3.3 Containment and Detection of Releases

40 CFR 270.16(g); 264.193

S-1 and S-2 are located within the same containment area as the vacuum pot (see Section E2.2.3 for a description of the secondary containment).

Any accumulated liquids in the containment area would be quickly observed via the tank and containment inspection procedures described in Section F and by the regular presence of facility operators in the vicinity. Process unit and containment basin inspections are described in Section F2.1, inspection schedules are found in Table F-1, and the inspection logs are found in Appendix F-1.

E2.3.4 Controls And Practices To Prevent Spills And Overflows

40 CFR 270.16(i); 264.194(a),(b); 264.195

S-1 and S-2 are equipped with sight glasses that enable operators to monitor the liquid level of their contents. They are also equipped with high level sensors that alarm upon reaching a high liquid level.

The secondary containment area is operated so that liquids from leaks or spills are localized and removed as soon as possible but within required regulatory time limits. Any significant accumulation of spilled liquids or incident precipitation will be removed within 24 hours, or sooner, if necessary to prevent overflow of the containment system. To minimize the occurrence of leaks or spills, the tanks and transfer operations are inspected daily per the inspection schedule in Section F. Releases of hazardous waste are handled as described in the applicable sections of the contingency plan found in Section G. Most releases are minor, associated with product transfer, and are cleaned up with dry absorbent and/or other material depending on the nature of the release. It is expected that pumpable releases of hazardous waste are directed to a tank in sound condition, with available capacity, and if not empty, it contains a material of similar characteristics. The waste is either pumped directly, or indirectly by a vacuum tanker and then deposited into an appropriate tank.

Rainwater accumulations in the containment area are visually inspected. If there are indications (e.g., a sheen) that the rain water has contacted waste material, the source will be investigated and corrective measures implemented as warranted. All storm water that accumulates in process secondary containment areas is transferred directly by pump or indirectly by use of a vacuum tanker to a non-hazardous waste tank. Unless contaminated by significant waste materials, this is not a regulated activity and is included for general informational purposes.

E2.3.5 Air Emission Controls

40 CFR 264.200; 270.16(k); 270.24; 270.27

The separators are an integral part of the vacuum pot unit and vent via a vacuum pump to a process vent meeting the definition of 40 CFR 264.1031. Thus, they are not subject to the standards of Subpart CC per 264.1080(b)(8). There are no pressure relief devices on these tanks.

E2.4 OTHER COMPONENTS

E2.4.1 Heat Exchanger

The vacuum pot unit is equipped with a noncontact external shell and tube heat exchanger to heat the liquid in the vacuum pot and produce vapor. Steam on the shell side is used to provide the heat for

vaporization. The liquid in the vacuum pot is pumped through the heat exchanger and back into the vacuum pot. The condensed steam is returned to the boiler and circulates again as steam.

E2.4.2 Knockout Pot

The knockout pot is a small stainless steel vessel located adjacent to the vacuum pot that serves to remove entrained liquids from the overhead vapor stream before the vapors are condensed, and return them back to the vacuum pot. Liquids can be entrained in the vapor stream as the vapor rises and/or because of boiling action. These entrained liquids will not necessarily have the same composition as the vapor itself, and may result in unexpected product characteristics if allowed to remain in the vapor. Thus, these liquids need to be “knocked out” of the vapor stream. This occurs in the knockout pot.

E2.4.3 Vessel S-3

S-3 is a small stainless steel vessel located adjacent to S-2 that collects the condensate from the plate and frame heat exchanger (condenser) See Section E2.4.3 below for details of this condenser. As most of the vapor phase organic constituents from the vacuum pot are condensed in the primary condenser, there is very little condensate to collect at this point in the unit. S-3 also serves as a last knockout pot for entrained liquid before the vapor stream goes to the vacuum pump and process vent.

E2.4.4 Condensers

The vacuum pot distillation unit is equipped with shell and tube and plate and frame noncontact heat exchangers that remove heat from the overhead vapor stream in order to condense it into a liquid. The primary condenser is a shell and tube heat exchanger located between the vacuum pot and separators S-1 and S-2, and is cooled with water from the cooling towers on the tube side. The secondary condenser is a plate and frame heat exchanger located between separators S-1 and S-2 and separator S-3, and is cooled with an ethylene glycol-water mixture from the chiller unit. The plate and frame condenser further reduces the temperature of exiting vapor, enhancing product recovery and reducing product loss to the process vent.

E3 THIN FILM EVAPORATOR

E3.1 PROCESS OVERVIEW

The thin film evaporator (TFE) is a vessel with a motorized wipe assembly that functions similarly to one tray of a fractionation column. As waste is fed into the unit, the wiper assemblies spread the waste onto the heated wall, allowing lighter components to evaporate and heavier or non-volatile materials (like solids) to exit the bottom of the unit by gravity. The vapors that exit are condensed and collected as liquid product or as an intermediate to further processing. The unit may be operated under vacuum to facilitate evaporation. Thin film evaporators have the ability to process viscous materials or materials with substantial solids content.

The thin film evaporator unit is located in the vacuum pot/thin filmer area just south of Tank Farm A (see Figure D-1, Facility Layout). A layout diagram of the secondary containment area is shown in Figure E-2, Vacpot Thinfilmer Column Area. A piping and instrument diagram (P&ID) depicting the thin film evaporator unit is included as Figure E-5, Thin Film Evaporator Process Flow Diagram.

The TFE unit consists of the thin film evaporator, a condenser, one receiver, one flush tank, a product pump, and a vacuum pump. The maximum operating temperature of the unit is about 340°F. The unit may be operated under vacuum to reduce the boiling point of high boiling liquids and achieve the desired separation more efficiently. Average operating temperatures are about 180°F, and vary with the boiling points of the liquids being processed.

E3.1.1 Waste Characterization

40 CFR 264.601(a)(1),(b)(1),(c)(1); 270.23

Wastewaters, halogenated solvent wastes, and non-halogenated solvent wastes may be processed by the TFE. Typical RCRA waste codes to be managed in this unit include but are not limited to F001, F002, F003, F004, F005, and D001. See Section C, Table C-1 for a more complete list of the RCRA Waste Codes that may be processed in this unit.

Wastes effectively processed by thin film evaporation are those with high paint pigment and solids content, such as used lacquer thinner. Product lacquer thinner is recovered overhead, and solids and heavy organic constituents are collected in the bottoms. This unit has a nominal processing rate of 870 gallons per hour. Processing rates will vary depending upon the waste being processed, the target product, and the desired product purity. With low boiling solvents and operating under a vacuum, the TFE unit can produce up to 80,500 gallons per month.

Reactive and incompatible wastes are not processed in this unit. The TFE unit is designated to process organic solvents with high solids content, and is constructed of stainless steel. Refer to Section C for information on how compatibility is determined. The entire system is steamed out between runs of different materials to avoid cross contamination of product. Process residues and condensed cleaning steam may be drained into drums (90-day storage) at designated points in the system. Some of the organic solvents may be classified as ignitable wastes. To accommodate these, the TFE unit is more than 15 feet from public ways or a property line that can be built upon, is properly grounded, and is connected to the plant closed-vent system.

E3.1.2 Potential for Releases

40 CFR 264.601, 270.23(b),(c),(e)

The TFE unit vents from both tanks via the vacuum pump to a process vent. There are no pressure relief devices on any of the unit components. Process vent emissions are regulated under Subpart AA and are directed to a VOC reduction unit, described in Section M, if they exceed the exemption thresholds.

(40 CFR 264.1080(b)(8)) It is likely that the TFE unit will be exempt from the Subpart AA standards due to its operation below the maximum allowed emissions limits. Calculations to support this exemption are located in Appendix M-2. The potential for release to groundwater and soil is mitigated by adherence to tank standards (Subpart J) for containment of the tank-like equipment within the unit (see Sections E1.2-E1.3 below) and by locating the entire unit in a secondary containment structure that conforms to Subpart J standards.

E3.1.3 Air Emission Controls

The TFE unit will be permitted as a miscellaneous 40 CFR 264 Subpart X unit, with some tank-like units and associated ancillary equipment. All of the TFE unit components are connected in series to a closed vent system which conveys any residual organic vapors to a process vent. Appendix M-2 provides calculations to verify that the unit does not exceed the emissions threshold of less than 1.4 kg/h (3 lb/h) or 2.8 kg/yr (3.1 tons/yr) under “worst case” conditions and is therefore exempted by 40 CFR 264.1032(a)(1). In the event that production increases emissions to or above the exemption thresholds, a VOC reduction unit regulated under 40 CFR 264 Subpart AA may be put into service on the process vent. Since all of the tank-like components of the TFE unit are indirectly vented (by venting through each other in series) to the process vent through the vacuum pump, with no vents anywhere else in the unit, 40 CFR 264 Subpart CC standards do not apply to these tank-like components. (40 CFR 264.1080(b)(8))

The TFE unit may be subject to 40 CFR 264 Subpart BB standards if the unit processes hazardous waste 300 or more hours per year in non-vacuum service. 40 CFR 264.1050(e) exempts equipment in vacuum service and 264.1050(f) exempts equipment operated less than 300 hours per year in hazardous waste service from Subpart BB standards. The TFE unit is used for processing mostly sludge-containing hazardous waste throughout the year, and is usually operated under vacuum. Refer to Section N for a discussion of Subpart BB standards. Romic does not intend to limit the types of waste processed in the vacuum pot unit, but the current economic trend is toward more non-hazardous rather than hazardous waste processing. Process logs will be used to document whether or not the Subpart BB exemptions apply.

E3.1.4 Closure

At closure, all hazardous waste remaining in the TFE unit will be treated onsite or shipped offsite for treatment and/or disposal, and all hazardous waste residues will be removed from the unit components, piping and containment system. Section J provides the Closure Plan for the entire facility. Section J1.8.1 discusses inventory elimination, and Section J1.8.2 discusses decontamination procedures for closure purposes.

E3.2 RECEIVER TANK AND FLUSH TANK

E3.2.1 Tank System Description

40 CFR 270.14(b)(1); 270.16(b); 264.194(b); 264.196; 264.199

The receiver tank and flush tank are two stainless steel vessels that receive condensed vapors (i.e., liquid) produced by the thin film evaporator system condenser. Details regarding these tanks are included in Table E-1. As product accumulates in these vessels, it may be sampled and analyzed to verify it meets product specification. If it meets product specifications, it is pumped to product tanks. The flush tank is configured so it can also be used to clean liquid lines and equipment at the end of a run.

E3.2.2 Tank Standards

40 CFR 264.192; 270.16(a), (e), (f); 264.192(a)-(e)

Romic's tanks were assessed by an independent, qualified, registered professional engineer. The certified assessment is included in this application as Section P.

E3.2.3 Containment and Detection of Releases

40 CFR 270.16(g); 264.193

The receiver and flush tanks are located in Tank Farm A, as shown on Drawing D-6, Tank Farm A&B. This tank farm is discussed in Section D2.2.

Any accumulated liquids in the secondary containment area would be quickly observed via the tank and containment inspection procedures described in Section F and by the regular presence of facility operators in the vicinity. Process unit and containment basin inspections are described in Section F2.1, inspection schedules are found in Table F-1, and the inspection logs are found in Appendix F-1.

E3.2.4 Controls and Practices to Prevent Spills and Overflows

40 CFR 270.16(i); 264.194(a),(b); 264.195

The receiver tank and the flush tank are equipped with sight glasses to enable operators to determine the liquid level for each vessel. Operators manually adjust thin film evaporator liquid production and product transfer out of these tanks to prevent overfilling. In the unlikely event of overflow, there would be no release into containment; liquid would overflow back into the condenser.

The secondary containment area is operated so that liquids from leaks or spills are localized and removed as soon as possible but within required regulatory time limits. Any significant accumulation of spilled liquids or incident precipitation will be removed within 24 hours, or sooner, if necessary to prevent overflow of the containment system. To minimize the occurrence of leaks or spills, the tanks and transfer operations are inspected daily per the inspection schedule in Section F. Releases of hazardous waste are handled as described in the applicable sections of the contingency plan found in Section G. Most releases are minor, associated with product transfer, and are cleaned up with dry absorbent and/or other material depending on the nature of the release. It is expected that pumpable releases of hazardous waste are

directed to a tank in sound condition, with available capacity, and if not empty, it contains a material of similar characteristics. The waste is either pumped directly, or indirectly by a vacuum tanker and then deposited into an appropriate tank.

Rainwater accumulations in the containment area are visually inspected. If there are indications (e.g., a sheen) that the rain water has contacted waste material, the source will be investigated and corrective measures implemented as warranted. All storm water that accumulates in process secondary containment areas is transferred directly by pump or indirectly by use of a vacuum tanker to a non-hazardous waste tank. Unless contaminated by significant waste materials, this is not a regulated activity and is included for general informational purposes.

E3.2.5 Air Emission Controls

40 CFR 264.200; 270.16(k); 270.24; 270.27

The receiver tank and the flush tank are an integral part of the TFE unit and vent via a vacuum pump to a process vent meeting the definition of 40 CFR 264.1031. Thus, they are not subject to the standards of Subpart CC per 264.1080(b)(8). There are no pressure relief devices on these tanks.

E3.3 TANK 105

E3.3.1 Tank System Description

40 CFR 270.14(b)(1); 270.16(b); 264.194(b); 264.196; 264.199

Tank 105 is a dished bottom fixed roof tank equipped with a mixer and vented through the plant closed-vent system to the plant VOC control device.

Information for Tank 105 is provided on Table D-3, Storage Tanks, located in Section D. Table D-3 indicates the capacity, configuration, material of construction, year of installation, intended waste service, and subpart CC status of the tank. Individual tank drawings indicating the dimensions of the tank are located in Appendix P. Figure D-6 is a layout diagram of tank Farms A and B, showing the location of Tank 105.

Tank 105 is designated for organic solvents. Some of these organic solvents may be ignitable wastes. Reactive and incompatible wastes are not stored in Tank 105, or in Tank Farms A and B. Refer to Section C for information on how compatibility is determined. Tank 105 is more than 15 feet from public ways or a property line that can be built upon, is properly grounded, is equipped with a conservation vent, which acts as a pressure-vacuum relief to maintain safe internal operating pressures, and is connected to the plant closed-vent system.

Tank feed is by manual connection of flexible hose(s) at the trough, and manual initiation of pump operation. There are no automated safety cut off, pressure control or bypass systems for Tank 105. The tank is operated at atmospheric pressure. Overfill prevention for Tank 105 is provided through a combination of manual level gauging and operator vigilance. The liquid level in a tank can be correlated

to a volume available in the tank and thus the amount of waste that can be transferred without overfilling can be determined. By dropping a measuring tape from a known point in the tank to the start of liquid level, the volume available for a transfer can be determined. The thin film operator will monitor the process, and will stop processing when the desired amount of waste is processed, the desired amount of product is produced, or Tank 105 is approaching capacity, whichever comes first.

Tank 105 may occasionally receive elevated temperature material from the Thin Film process. For this reason, it is vented through the plant closed-vent system to a control device as discussed in Section M. In addition, Tank 105 is equipped with a conservation vent, which acts as a pressure-vacuum relief, to maintain safe operating pressures.

At closure, all hazardous waste stored in Tank farms A&B will be treated onsite or shipped offsite for treatment and/or disposal, and all hazardous waste residues will be removed from the tanks, piping and containment system. Section J provides the Closure Plan for the entire facility. Section J1.8.1 discusses inventory elimination, and Section J1.8.2 discusses decontamination procedures for closure purposes.

E3.3.2 Tank Standards

40 CFR 264.192; 270.16(a), (e), (f); 264.192(a)-(e)

Romic's tanks were assessed, as discussed in Section D2.1, by an independent, qualified, registered professional engineer. The certified assessment is included in this application as Section P.

E3.3.3 Containment and Detection of Releases

40 CFR 270.16(g); 264.193

Tank 105 is located within Tank Farm A. Tank Farm A provides secondary containment through an impermeable base of concrete with curbs surrounding the base. The containment slab is constructed of a minimum 10" 3000 lb concrete with #5 rebar 12" on-center each way. The slab is monolithic, thus there are no cold joints. All hazardous waste storage areas are underlain by a 30 mil HDPE liner. The concrete is sealed with a chemical-resistant epoxy coating. Refer to Drawing S-1 of 1 in Appendix P for design and details of Tank Farm A and B containment construction. The containment area is sloped to a low point at a blind sump from which any spills or leaks draining away from the tank may be manually pumped.

Tank Farm A is located outside under roofing with open sides; therefore exposure to rainfall is minimal. As discussed in Section B6.3, the maximum 25-year, 24-hour rainfall amount was determined to be about 3.12-inches. The area is equipped with an AFFF (aqueous film-forming foam) based fire suppression system. No tank ancillary equipment is located outside of the containment structure.

The total secondary containment capacity calculated for tank farm A is 1592 cubic feet. The unit has sufficient containment capacity to hold the capacity of the largest tank, or 789 cubic feet. Since these tank farms are under roof, the amount of rainfall that will be collected is minimal. Table D-5 summarizes the available and required secondary containment capacity for this tank farm unit.

Any accumulated liquids in a containment area would be quickly observed via the tank and containment area inspection procedures described in Section F and by the regular presence of facility operators in the vicinity. Tank system and containment basin inspections are described in Section F2.1, inspection schedules are found in Table F-1, and the inspection logs are found in Appendix F-1.

E3.3.4 Controls and Practices to Prevent Spills and Overflows

40 CFR 270.16(i); 264.194(a),(b); 264.195

Tank 105's overflow protection is discussed above, in Section E3.3.1. This is a manual operation, requiring an operator to measure the level in Tank 105, connect the flexible hoses to the proper fittings, open/close valves, initiate the pump operation, and monitor the fill. There are no automated controls such as level sensing devices, high level alarms, automatic feed cutoff, bypass to a standby tank, etc.

This containment area is operated so that liquids from leaks or spills are localized and removed as soon as possible but within required regulatory time limits. Any spilled liquids, incident precipitation, or other liquids will be removed within 24 hours, or sooner if necessary to prevent overflow of the containment system. To minimize the occurrence of leaks or spills, the tanks and transfer operations are inspected regularly per the inspection schedule in Section F. Most releases are expected to be minor and could be cleaned up with dry absorbent materials and/or other material depending on the nature of the release. Large releases of hazardous waste would be handled as described in the Contingency Plan, Section G of this application. It is expected that the hazardous waste materials released would be pumped to a tank in sound condition, that has available capacity, and if not empty, it contains a material of similar characteristics. The waste may be pumped directly or the material would be picked up by a vacuum tanker and then deposited into an appropriate tank.

Rainwater accumulations in the tank containment area will be visually inspected. If there are indications (e.g., a sheen) that the rain water has contacted waste material, the source will be investigated and corrective measures implemented as warranted. All storm water that accumulates in tank farm secondary containment areas, is transferred directly by pump or use of a vacuum tanker to a non-hazardous waste tank. This activity does not require a permit; this description is included for general informational purposes.

E3.3.5 Air Emission Controls

40 CFR 264.200; 270.16(k); 270.24; 270.27

Tank 105, when it is operating as part of the Thin Film Evaporator system, vents through a Subpart AA-regulated process vent. At other times, it serves as a storage tank, and thus is subject to Subpart CC. Tank 105 is vented to the facility's closed-vent system and control device at all times, satisfying both Subpart AA and Subpart CC Tank Level 2 control requirements. Subpart AA provisions are discussed in Section M of this application.

Tank 105 ancillary equipment consists of piping systems which are located within the containment basin. The liquid lines to and from Tank 105 are subject to Subpart BB air emission standards. These piping

systems and their components have been properly identified in accordance with Subpart BB provisions. The specific list of Tank 105 and all other Subpart BB-subject equipment (connectors, joints, etc.), location, unique identifiers, and most recent inspection are included in Appendix F-1.

E3.4 OTHER COMPONENTS

The thin film evaporator system is equipped with a noncontact cooling heat exchanger that removes heat from the overhead vapor stream in order to condense it into a liquid. The condenser is cooled with water from the Romic cooling towers.

E4 ACID-BASE NEUTRALIZATION

Acid-base neutralization is a planned process that will be conducted in Tanks 308 and 309 in Tank Farm G. A layout diagram showing Tank Farm G is included as Figure E-6. Use of the acid-base neutralization tanks may be initiated prior to construction and operation of the planned wastewater treatment system described in Section E7.1 below. Acid-base neutralization may also process wastes that require additional treatment after distillation to adjust pH.

Since precipitation of dissolved solids is likely to occur during the neutralization process, the neutralization process includes a plate and frame filter press through which the neutralized effluent may be filtered prior to transfer to a storage tank or additional processing in the wastewater treatment system. Appendix E-1 provides information on the JWI Filter Press planned for this application.

E4.1 TANK SYSTEMS DESCRIPTION

40 CFR 270.14(b)(1); 270.16(b); 264.194(b); 264.196; 264.199

Planned process tanks 308 and 309, located in Tank Farm G, are 5000 gallons each in capacity, and constructed of rubber-lined carbon steel with internal cooling coils. Cooling will be provided by water from Romic's cooling towers and/or by a chiller system. The tanks will operate at atmospheric pressure. The process tanks planned for Tank Farm G are listed in Table E-1. Table E-1 indicates the capacity, configuration, material of construction, planned year of installation, intended waste service, and Subpart CC status for each process tank. Individual tank drawings indicating the dimensions of each tank are located in Appendix P. Figure E-6 is a layout diagram of Tank Farm G.

Tanks 308 and 309 are operated at ambient temperature most of the time. The maximum temperature of the liquid within the tanks is controlled during neutralization via a temperature sensor that controls an automated feed valve. If the heat of reaction causes the tank contents' temperature to rise above a designated temperature, the valve will reduce the feed rate of the material being added, and slow the reaction. Once the cooling coils return the liquid to the desired operating temperature, the feed valve will increase the flow of reactant into the tank. The feed rate of the reactant liquid will be adjusted to correlate to the heat removal capacity of the cooling coils.

At closure, all hazardous waste processed in Tank Farm G will be treated onsite or shipped offsite for treatment and/or disposal, and all hazardous waste residues will be removed from the tanks, piping and containment system. Section J provides the Closure Plan for the entire facility. Section J1.8.1 discusses inventory elimination, and Section J1.8.2 discusses decontamination procedures for closure purposes.

E4.2 NEW TANK STANDARDS

40 CFR 264.192; 270.16(a), (e), (f); 264.192(a)-(e)

The hazardous waste process tanks in Tank Farm G will be assessed by an independent, qualified, registered professional engineer to attest that the tank system has sufficient structural integrity and is acceptable for storing and treating hazardous waste, as discussed in Section D2.1. Prior to placing the tanks in use, the tanks and ancillary equipment will be inspected by a professional engineer to check for weld breaks, punctures, scrapes of protective coatings, cracks, corrosion, and other structural damage or inadequate construction/installation. Tightness testing will be performed by filling each tank system with water and inspecting for leaks. Any deficiencies discovered during these inspections will be remedied prior to placing the tanks in use. The certified assessments for installation and tightness testing will be submitted to USEPA prior to putting these tanks in use. Schematics of these tanks are included in Section P.

E4.3 CONTAINMENT AND DETECTION OF RELEASES

40 CFR 270.16(g); 264.193

Tank Farm G provides secondary containment through an impermeable base of concrete with curbs surrounding the base. The containment slab is constructed of 10" 3000 lb concrete with #5 rebar 12" on-center each way. The slab is monolithic, thus there are no cold joints. All hazardous waste storage areas are underlain by a 30 mil HDPE liner. The concrete basin is sealed with a chemical resistant epoxy coating. Tank Farm G containment is sloped to a low point at a blind sump from which any spills or leaks draining away from the tanks may be manually pumped.

Tank Farm G is located outside under roofing with three open sides, the fourth side opening onto container storage Building 2; therefore exposure to rainfall is minimal. As discussed in Section B6.3, the maximum 25-year, 24-hour rainfall amount was determined to be about 3.12-inches. The area is equipped with an AFFF (aqueous film-forming foam) based fire suppression system. No tank ancillary equipment will be located outside of the secondary containment structure.

Tank Farm G has sufficient containment capacity to hold the capacity of the largest tank, or 8,500 gallons (Tanks 511 and 512). Since this tank farm is under roof, the amount of rainfall that will be collected is minimal. Table E-2 summarizes the available and required secondary containment capacity for this tank farm unit.

Any accumulated liquids in a containment area would be quickly observed via the tank and containment area inspection procedures described in Section F and by the regular presence of facility operators in the

vicinity. Tank system and containment basin inspections are described in Section F2.1, inspection schedules are found in Table F-1, and the inspection logs are found in Appendix F-1.

E4.4 CONTROLS AND PRACTICES TO PREVENT SPILLS AND OVERFLOWS

40 CFR 270.16(i); 264.194(a),(b); 264.195

Tanks 308 and 309 will be equipped with level sensors and level controls to prevent overfilling. All transfers into and out of Tanks 308 and 309 will be through an enclosed (piped) transfer system.

This containment area is operated so that liquids from leaks or spills are localized and removed as soon as possible but within required regulatory time limits. Any spilled liquids, incident precipitation, or other liquids will be removed within 24 hours, or sooner if necessary to prevent overflow of the containment system. To minimize the occurrence of leaks or spills, the tanks and transfer operations are inspected regularly per the inspection schedule in Section F. Most releases are expected to be minor and could be cleaned up with dry absorbent materials and/or other material depending on the nature of the release. Large releases of hazardous waste would be handled as described in the applicable sections of the emergency response procedures. It is expected that the hazardous waste materials released would be pumped to a tank in sound condition, that has available capacity, and if not empty, it contains a material of similar characteristics. The waste may be pumped directly or the material would be picked up by a vacuum tanker and then deposited into an appropriate tank.

Rainwater accumulations in the tank containment area will be visually inspected. If there are indications (e.g., a sheen) that the rain water has contacted waste material, the source will be investigated and corrective measures implemented as warranted. All storm water that accumulates in tank farm secondary containment areas, is transferred directly by pump or use of a vacuum tanker to a non-hazardous waste tank. This activity does not require a permit; this description is included for general informational purposes.

E4.5 AIR EMISSION CONTROLS

40 CFR 264.200; 270.16(k); 270.24; 270.27

Tanks 308 and 309 are designed primarily for aqueous acid/alkali service, but may occasionally handle materials subject to Subpart CC (> 500 ppm volatile organics). Because the tanks are less than 75 m³ in capacity, they could manage organic materials with a vapor pressure up to, but below 76.6 kPa to be subject to Level 1, rather than Level 2, controls. Acetone is the highest vapor pressure material currently processed at the facility, with a vapor pressure of 71 kPa @ 46.1°C (see Table D-6). The organic content of materials processed in tanks 308 and 309, as determined through waste profiling and acceptance procedures indicated in Section C, will be maintained in the facility operating record.

Tanks 308 and 309 are normally operated at ambient temperature, and are not used for a waste stabilization process; thus they are eligible for Tank Level 1 controls. They will be fixed roof tanks equipped with conservation vents to provide vacuum/pressure relief. The material placed into the tanks

will have a maximum organic vapor pressure which is less than the maximum organic vapor pressure limit for the tank's design capacity. These tanks will not be vented to the plant closed vent system.

Although tanks 308 and 309 may occasionally handle materials with an organic content of at least 10% by weight, they will not be used for 300 or more hours per year in this service, thus Subpart BB air emission controls are not required for these tanks. (40 CFR 264.1050(f)) The organic content of materials processed in tanks 308 and 309, as determined through waste profiling and acceptance procedures indicated in Section C, will be maintained in the facility operating record to verify that these units are exempt from Subpart BB air emission controls.

E5 FUEL BLENDING

E5.1 PROCESS OVERVIEW

Fuel Blending is the process of mixing different waste materials to make a blend that can be burned by a cement kiln or other user of hazardous waste fuel for heat. The primary specifications are heat value (measured in BTU/lb), solids content, water content, and halogen content. Specifications for the final blended fuel are defined by the recipient who burns the hazardous waste fuel in an authorized industrial furnace or boiler. Incoming waste streams with sufficient BTU content are combined in proportions determined through laboratory analysis and generator-supplied information.

After the waste is received and the laboratory performs the analytical tests, the waste will be assigned to a specific tank or railcar. The tanker truck will be pumped into a specific storage tank or railcar. If the waste was received in containers, a Romic yard tanker will be used to empty the contents of the containers. The yard tanker will then transfer the waste into an appropriate hazardous waste storage tank or railcar within 10 days. Romic may also pump material from containers directly into storage tanks.

If the waste to be transferred into a fuel blending tank or railcar is not known to be compatible with waste already in the tank or railcar, a bench-scale waste compatibility test is used to verify that there are no adverse reactions from combining the waste streams. If this test indicates an adverse reaction, the incoming waste will be transferred into a different tank that has waste compatible with the incoming material.

The determination of which tank to use is made by the Romic laboratory based on analytical results for the key blending specifications. The target specifications depend on the disposition of the hazardous waste fuel. There may be specifications for heat content (BTU/lb), percent water, percent solids and other physical and/or chemical parameters. There may or may not be levels at which the waste could be rejected on a facility-by-facility basis.

After the target blend specification is reached, and the sample results indicate that fuel has blended to appropriate specifications, one or more tanks will be pumped into a tanker truck or pumped directly into a railcar. If for some reason the target specification has not been achieved, the non-conforming waste may be distributed to another tank for addition of other blending materials. A final sample is collected from the

railcar to assure quality. After the analytical tests confirm waste fuel is within the specifications of the receiving facility, the railcar is shipped under manifest to an off-site Romic approved facility.

E5.1.1 Waste Characterization

40 CFR 264.601(a)(1),(b)(1),(c)(1); 270.23

Fuel Blending at the facility is typically used to manage organic solvents, oil-based paints, oily wastes, gasoline, and kerosene. Other types of industrial chemicals such as alcohols, ketones, or aromatic hydrocarbons may also be fuel blended. On-site generated distillation bottoms, off-spec solvents, liquefaction waste, and other streams (including tank truck sludge) are also used in fuel blending provided they have sufficient heat content. RCRA waste codes to be managed in these units include but are not limited to the following: F001, F002, F003, F004, F005, D001, D004-D011, D018, D019, D021-D030, D032-D036, D038-D040, and D043. See Section C, Table C-1 for a more complete list of the RCRA Waste Codes that may apply to these waste streams.

E5.1.2 Potential for Releases

Fuel blending at Romic will be conducted in closed-roof steel tanks equipped with conservation vents, and mixers to blend organic liquids to customer specifications. Adherence to tank and containment standards (including Subpart BB and CC air emission standards) will adequately mitigate any potential for releases to air, groundwater, and soil. Fuel blending tanks operate at ambient temperatures and pressures.

E5.2 TANK 105

In addition to receiving elevated temperature process liquid and/or sludge from the thin film evaporation system when that unit is operating, fuel blending at ambient temperatures may also be conducted in Tank 105 when the thin film evaporator is not running. Tank 105 is part of the thin film evaporator system discussed above, and is connected to the plant closed vent system. Refer to Section E3.3 for discussion of tank 105.

E5.3 PLANNED TANKS 137 AND 138

E5.3.1 Description

40 CFR 270.14(b)(1); 270.16(b); 264.194(b); 264.196; 264.199

Information on fuel blending Tanks 137 and 138 planned for Tank Farm D is provided in Section D2.4.1 through D2.4.5 and Table D-3 of this application. Individual tank drawings indicating the dimensions of each tank are located in Appendix P.

E5.3.2 Air Emission Controls

40 CFR 264.200; 270.16(k); 270.24; 270.27

Tanks 137 and 138 will be eligible for Tank Level 1 controls because they are less than 75 m³ in capacity, operate at ambient temperature, are not used for waste stabilization activities, and the vapor pressure of the materials in these tanks will not exceed 76.6 kPa. As is the case with the other organic storage tanks at Romic, acetone is the material that exhibits the highest vapor pressure (71 kPa at 46.1 °C) seen at the site. Also, because fuels have strict halogen limits, and concentrations of chlorinated solvents must be very low to meet the halogen limitations imposed by end users of the fuel, chlorinated compounds are introduced in limited quantities and would not significantly impact the vapor pressure limits of any storage tank at the facility.

E6 AEROSOL DEPRESSURIZATION

The aerosol container depressurization unit is located in the West Bay processing area, under a roof and within a concrete containment area. This unit will be permitted as a miscellaneous process unit with associated ancillary equipment and one 90-day collection container. The unit itself is 22 inches by 20 inches and is 27 inches high, and contains a continuous feed and discharge tube for the aerosol cans, a rotating blade section that moves the cans along and cuts into them, a collection chamber that funnels the propellant and liquid contents of the cans to a fixed transfer hose, and an air-driven transfer pump. The collection funnel is not classified as a container-like unit for permitting purposes since it is only a funnel and cannot retain liquids. The fixed transfer hose is connected to a closed top 55 gallon DOT drum, which is a 90-day container. The 55 gallon drum is connected by a fixed vent line to a carbon bed.

The aerosol depressurization unit is operated under a vacuum maintained by a large air driven diaphragm pump with intake connections at the can feed and exit tubes. This draws air into the tubes, and directs any collected vapor/propellant to a carbon bed. The unit is not subject to air emission controls under 40 CFR 264 Subpart AA or BB, because it is not one of the applicable Subpart AA processes, and because it does not operate more than 300 hours per year in non-vacuum service. 264.1050(f) provides this exemption from Subpart BB requirements. Subpart CC provisions do not apply to the collection funnel because it is less than 0.1 cubic meter (26 gallons). Subpart CC standards do not apply to the 55 gallon DOT receiving drum because the fixed transfer hose and piped vent line to the carbon beds are securely fastened to the bung openings of the drum so there are no visible holes, gaps or other open spaces into the interior of the container, and the carbon beds provide removal of organic vapors displaced from the drum during filling and depressurizing activities. 264.1082(c)(2)(v) provides for this exemption.

At closure, all hazardous waste remaining in the West Bay will be treated onsite or shipped offsite for treatment and/or disposal, and all hazardous waste residues will be removed from the aerosol depressurization unit and the containment system. Section J provides the Closure Plan for the entire facility. Section J1.8.1 discusses inventory elimination, and Section J1.8.2 discusses decontamination procedures for closure purposes.

E6.1 PROCESS OVERVIEW

This activity involves opening aerosol cans by cutting into them in an enclosed chamber to remove propellant and can contents. The propellant is directed through the receiving drum (90-day container) to an air emission control unit consisting of a carbon bed. The can contents drain by gravity to a small (approximately 3 gallons) collection funnel, and are continuously pumped into a 55 gallon closed top receiving drum (90-day container). The pump runs continuously whenever the unit operates. When the drum is full, it is disconnected from the aerosol depressurization unit and closed with bung closures. The drum contents are sampled to determine compatibility, and may be transferred to storage, the on-site fuel blending operation, or other appropriate waste treatment process. An empty receiving drum is then placed into service by reconnecting the transfer hose and vent line to it. Depressurized aerosol containers are managed as empty containers, and processed for scrap metal recovery or for disposal.

The aerosol depressurization unit consists of a feed tube, a blade that punctures cans as they travel along the tube, a liquid collection funnel (approximately 3 gallon capacity) which is not used to retain liquids, but to direct them to the pump, and a pump that continuously discharges the contents of the collection chamber to an accumulation drum when the unit is operating. The accumulation drum is a 90-day container, and is vented to a carbon bed to control organic emissions.

Aerosol cans are fed into one end of the feed tube. The feed tube is roughly u-shaped, sloping downward toward the unit and upward again away from the unit. As cans reach the low point of the tube, they are punctured by a blade that rips a lengthwise hole in the cans. The cans' contents drain by gravity into the collection funnel, where they are immediately pumped over to the receiving drum. As additional cans are fed into the feed tube, the punctured cans are pushed to the discharge end of the tube. The punctured cans that come out of the discharge end are collected in a 55-gallon drum.

Typically, the aerosol depressurization unit is operated approximately 25 hours per month for hazardous waste aerosol containers, producing an average of 1 drum per month of collected waste. This varies, and depends on whether the aerosol cans being processed are full or almost empty. The maximum feed rate is approximately 1.75 drums of aerosol cans per hour. The unit depressurizes and empties non hazardous waste aerosol cans as well as hazardous waste aerosol cans.

The West Bay is operated as a 90-day storage area. The liquid receiving drum is allowed up to 90 days to fill before it must be closed and moved from the area. The carbon beds on the vacuum pump and receiving drum are changed as needed. The RCRA-empty metal cans are collected in a drum and crushed to facilitate recycling or disposal of the steel.

E6.1.1 Waste Characterization

40 CFR 264.601(a)(1),(b)(1),(c)(1); 270.23

Waste types include flammable and non-flammable aerosols such as paints, degreasers, solvents, adhesives, household hazardous waste, and non-hazardous wastes. See Section C, Table C-1 for a more

complete list of the RCRA Waste Codes that may apply to these waste streams. The aerosol cans may be completely full, partly full, or completely empty.

Since aerosol cans are original manufacturer's containers, they are not sampled and analyzed by the laboratory with each inbound load as other inbound wastes are. The receiving drum is assumed to contain organic hazardous waste, so there is no need to determine exemption level concentrations such as 10% or 500 ppmv organics. Once the accumulation drum becomes full, it is sampled and analyzed by the laboratory to determine its ultimate destination, which may include fuel blending, offsite incineration, or other offsite treatment.

E6.1.2 Potential for Releases

40 CFR 264.601, 270.23(b),(c),(e)

The aerosol depressurization unit is vented through the enclosed collection funnel and transfer hose by the continuously operating pump, into a 55 gallon closed top receiving drum, which is vented to a carbon bed system to remove organic emissions. Although the propellant and liquid are directed into the enclosed collection funnel when the cans are cut, there is a potential for fugitive organic emissions out the feed and discharge tubes from the release of propellants when cans are punctured. To reduce these fugitive emissions, a large air driven diaphragm pump was installed so its suction connection draws vapors/propellant from the feed and discharge tubes as cans are punctured, and vents them into the carbon beds. The aerosol unit operates under vacuum provided by the two pumps.

The unit components that briefly contain liquid are the collection funnel, transfer hose, and the pump. There is a potential for leaks from the hose connections of the collection funnel and pump, and the pump itself. These components, and the 55 gallon DOT receiving drum, are observed for leaks during the weekly inspection. Inspections are discussed in Section F. The inspection form is found in Appendix F-1.

The West Bay provides secondary containment through an impermeable base of concrete with curbs and a ramp surrounding the base. The containment slab is constructed of a 10" thick 3000 lb concrete with #5 rebar 12" on-center each way. The slab is monolithic, thus there are no cold joints. All hazardous waste containment areas are underlain by a 30 mil HDPE liner. The concrete is sealed with a chemical-resistant epoxy coating. Refer to Drawing P103, 2 of 4, in Appendix P for design and details of typical Center Area containment and construction. The West Bay containment area is sloped to a low point at a blind sump from which any spills or leaks draining away from the unit may be manually pumped. No unit ancillary equipment is located outside of the secondary containment structure.

The West Bay has sufficient containment capacity (505 cubic feet) to hold 10% of the capacity of the maximum number of drums that could be put into that area (153 cubic feet). Table D-5 summarizes the available and required secondary containment capacity for this containment unit. The West Bay is located outside under roofing with open sides; therefore exposure to rainfall is minimal. As discussed in Section B6.3, the maximum 25-year, 24-hour rainfall amount was determined to be about 3.12-inches.

Any accumulated liquids in the West Bay containment area would be quickly observed via the containment area inspection procedures described in Section F and by the regular presence of facility operators in the vicinity. Containment basin inspections are described in Section F2.1, inspection schedules are found in Table F-1, and the inspection logs are found in Appendix F-1.

E7 OTHER PROCESSES

Romic will conduct other waste management activities that are exempt from RCRA permitting requirements. These are described below, along with the rationale for their exemption.

E7.1 WASTEWATER TREATMENT

Romic plans to install a wastewater treatment system in Tank Farm G. The system will be designed to treat aqueous waste streams including hazardous wastes and non-hazardous wastes. All treatment will take place in tanks, specifically Tanks 304-309 and 511 and 512.

The effluent from this system will be discharged to the City of Chandler municipal wastewater treatment system, and will be subject to the pretreatment standards imposed by the City in an industrial waste water discharge permit. This system is excluded from permitting requirements under 40 CFR 270.1(c)(2)(v).

E7.2 DRUM CRUSHING

Romic has a drum crushing unit in the West side processing area. The Drum Crusher system is designed and built to neatly crush steel drums. These drums typically come from various on-site activities, and from off-site. Since the drum crusher will only handle drums that meet the definition of empty in 40 CFR 261.7, this activity is not a hazardous waste treatment activity. It is included in this Part B permit application for informational purposes. Drums not meeting the definition of empty will be emptied and the contents consolidated into containers of compatible wastes and either processed onsite or shipped offsite for disposal.

The empty crushed drums are placed in a roll-off bin destined for metal recycling or disposal. Empty drums (uncrushed) may also be sent offsite for reconditioning or disposal.

E7.3 GLASS STILL

Romic is planning to install a small distillation system, constructed of glass, and designed to reclaim smaller batches of high value solvents. It would be used exclusively for solvent recycling, and thus would be exempt from permitting requirements. Emissions from process vents from this process would be controlled in accordance with Section M of this application and 40 CFR Part 264, Subpart AA.

E7.4 DEBRIS DECONTAMINATION

Romic conducts decontamination of debris and equipment in the rail loading and unloading containment area. This activity is not subject to permitting requirements as set forth in 40 CFR 268.45. The

decontamination technologies used are physical extraction techniques, such as abrasive blasting and high pressure steam and water sprays, and chemical extraction, such as water washing and spraying. Residuals from decontamination may be managed as hazardous waste. Decontaminated debris meeting the performance standards of 40 CFR 268.45 may be disposed of as nonhazardous waste, or may be managed as scrap metal for recycling, or as hazardous debris.

E7.5 TANKER WASHOUT

Romic conducts tank truck washout operations. Residues remaining in RCRA-empty and nonempty tank trucks are removed using high pressure water and other physical means. Residues removed from tank trucks may be managed as hazardous waste. This activity does not constitute treatment of hazardous waste, but is properly classified as transfer.

E7.6 AEROSOL UNIT RECEIVING DRUM

The aerosol depressurization unit receiving drum is a 90-day accumulation container, and is not intended to be permitted. The container is disconnected from the unit, closed and removed from the West Bay when it either becomes full, or approaches the 90-day accumulation limit.

E7.7 VOC UNIT RECEIVING TANK T-100

It is intended that T-100 be a 90-day storage tank rather than a permitted storage tank. The VOC unit liquid effluents, consisting of seal water and condensed organic liquids, are manually transferred daily to receiving tank T-100. This small tank is manually pumped daily to a hazardous waste storage tank.

E7.8 PROCESS BOTTOMS RECEIVING DRUMS

55-gallon drums are used to collect the residues from distillation equipment at the end of runs. They are placed in designated locations under process units to collect residues, drips and condensate from steam cleaning. These drums are intended to be 90-day accumulation drums, and will be removed from the process area when they become full or approach the 90 day storage limit. They are kept closed when they are not actively receiving residues.

TABLES

TABLE E-1 PROCESS TANKS

Farm	Tank ID	Max. Capacity	Working Capacity	Type; Mat'l Construction	Installation Year	Date of Assessment	Waste Types Handled ⁽¹⁾	Subpart AA/CC Level/Rationale	Max VP
Column	R30	2900 gal	2800 gal	Horizontal; Stainless steel	2000	1/26/05	Organic, Aqueous	Not subject to CC; subject to AA; tank with a process vent	n/a
	Separator	85 gal	75 gal	Dished bottom; Stainless steel	2000	1/26/05	Organic, Aqueous	Not subject to CC; subject to AA; tank with a process vent	n/a
Vac Pot	Vac Pot	1700 gal	1500 gal	Dished bottom; Stainless steel	1995	1/26/05	Organic, Aqueous	Not subject to CC; subject to AA; tank with a process vent	n/a
	S-1	600 gal	550 gal	Dished bottom; Stainless steel	1995	1/26/05	Organic, Aqueous	Not subject to CC; subject to AA; tank with a process vent	n/a
	S-2	600 gal	550 gal	Dished bottom; Stainless steel	1995	1/26/05	Organic, Aqueous	Not subject to CC; subject to AA; tank with a process vent	n/a
TFE	Receiver	225 gal	200 gal	Dished bottom; Stainless steel	1991	1/26/05	Organic, Aqueous	Not subject to CC; subject to AA; tank with a process vent	n/a
	Flush Tank	225 gal	200 gal	Dished bottom; Stainless steel	1991	1/26/05	Organic, Aqueous	Not subject to CC; subject to AA; tank with a process vent	n/a
G	304 ^{(2),(3)}	4,100 gal		Cone bottom; HDPE	2005	2/15/05 (30% design)	Acid, Alkaline, Aqueous	Not subject; < 500 ppmw organics	n/a
	305 ^{(2),(3)}	4,100 gal		Cone bottom; HDPE	2005	2/15/05 (30% design)	Acid, Alkaline, Aqueous, Oxidizer	Not subject; < 500 ppmw organics	n/a
	306 ^{(2),(3)}	4,100 gal		Cone bottom; HDPE	2005	2/15/05 (30% design)	Acid, Alkaline, Aqueous, Oxidizer	Not subject; < 500 ppmw organics	n/a
	307 ^{(2),(3)}	4,100 gal		Cone bottom; HDPE	2005	2/15/05 (30% design)	Acid, Alkaline, Aqueous, Oxidizer	Not subject; < 500 ppmw organics	n/a

TABLE E-1 PROCESS TANKS

Farm	Tank ID	Max. Capacity	Working Capacity	Type; Mat'l Construction	Installation Year	Date of Assessment	Waste Types Handled ⁽¹⁾	Subpart AA/CC Level/Rationale	Max VP
G	308 ⁽²⁾	5,000		Cone bottom; Rubber lined carbon steel	2005	2/15/05 (30% design)	Acid, Alkaline (including organic acids & alkalines)	Level 1; < 75 m ³ , max vp < 76.6 kPa ⁽⁴⁾	n/a
	309 ⁽²⁾	5,000		Cone bottom; Rubber lined carbon steel	2005	2/15/05 (30% design)	Acid, Alkaline (including organic acids & alkalines)	Level 1; < 75 m ³ , max vp < 76.6 kPa ⁽⁴⁾	n/a
	511 ^{(2),(3)}	8,500		Sloped bottom; HDPE	2005	2/15/05 (30% design)	Wastewater	n/a	n/a
	512 ^{(2),(3)}	8,500		Sloped bottom; HDPE	2005	2/15/05 (30% design)	Wastewater	n/a	n/a
	FP-101 ^{(2),(3)}	100 ft ³		PE or PP	2005	2/15/05 (30% design)	Wastewater/filter cake	n/a	n/a
	FP-102 ^{(2),(3)}	100 ft ³		PE or PP	2005	2/15/05 (30% design)	Wastewater/filter cake	n/a	n/a
	RV-101 ^{(2),(3)}	188 ft ³		PE or PP	2005	2/15/05 (30% design)	Wastewater/filter cake	n/a	n/a

Notes:

- (1) For key to Waste Types Handled, see Table D-4
 - (2) Future Unit
 - (3) Exempt dedicated wastewater treatment system tanks
 - (4) Highest vapor pressure material processed in bulk at the facility is acetone, with a vapor pressure (vp) of 71 kPa.
- n/a = Not applicable
 PE = Polyethylene
 PP = Polypropylene

TABLE E-2 PROCESS TANK SECONDARY CONTAINMENT

	Surface Area (sq. ft.)	Wall Height	Gross Containment (cu. ft.)	Displacement (cu. ft.)	Net Containment (cu. ft.)	Containment Required (40 CFR) (cu. ft.)	Containment Required (UFC) (cu. ft.)
VacPot-TFE-Column Area	1569	11"	1451	30.9	1420	367	1039
Tank Farm D	See Section D2.4.3 and Table D-5						
Tank Farm G	2158		2719	464	2255	1136	2099
Area A1	1080	16"	1440				
Area A2	377	7.5"-18" Avg = 12.75"	401				
Area A3	701	14"-16" Avg = 15"	877				

Notes:

Gross containment includes sumps in some tank farms.























Displacement is due to footings and equipment.

Containment required under 40 CFR is based on the larger of: (1) Capacity of largest tank and (2) 10% of aggregate tank capacity.

Containment required under UFC is based on the capacity of the largest tank plus 20 minutes of sprinkler design flow.

To simplify calculation of gross containment, Tank Farm G was artificially divided into three areas (areas A1, A2, and A3).

FIGURES

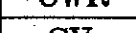
	Pipe Reducer
	Plate and Frame Heat Exchanger
	Manual valve
 DR	Drain valve
 SV	Sample valve
	Control Valve
	Flow Switch
	Y-Strainer
	Pump
	Pipe expansion joint
	Steam Trap
 PG	Pressure gage
 TG	Temperature gage
 VPG	Vacuum/pressure gage
 PDT	Pressure differential transmitter
 HLA	High level alarm
 LLA	Low level alarm
 TT	Temperature transmitter
 PT	Pressure transmitter
 SG	Sight glass
CWS	Cooling water supply
CWR	Cooling water return
SV	Sample valve
	Check valve
CS	Chillent supply
CR	Chillent return
 PRV	Pressure relief valve
	Flange
	Heat exchanger/ condenser
SQRF	Steam quick release fitting

 ROMIC ENVIRONMENTAL TECHNOLOGIES ENGINEERING DEPARTMENT					
REV	DATE	REVISION	APP	ROMIC - SOUTHWEST CHANDLER, ARIZONA	DATE: 05-11-04 SCALE: NONE
KEY TO SYMBOLS				E-1	

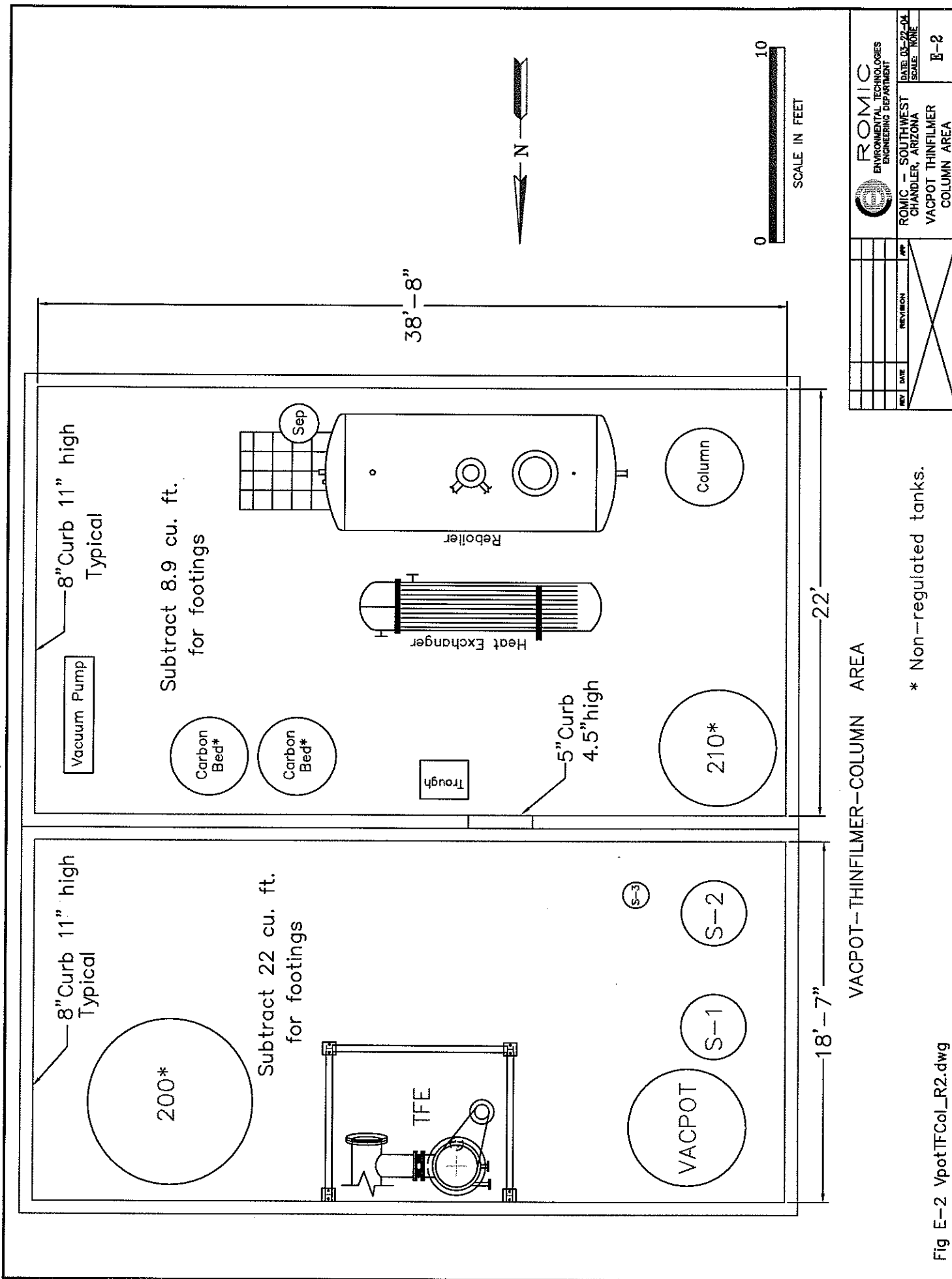
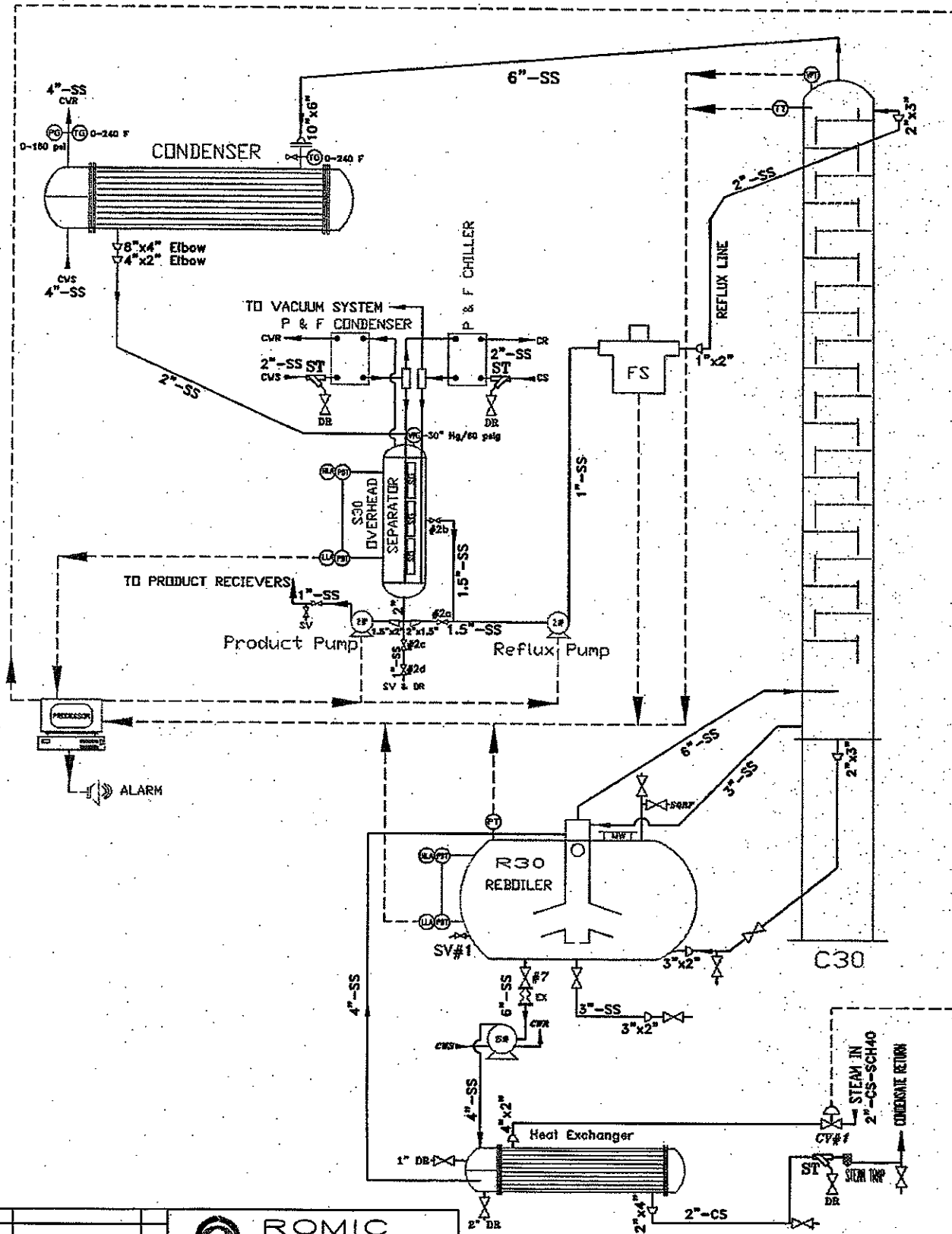



Fig E-2 VpotIFCol_R2.dwg



REV	DATE	REVISION	APP



ROMIC
 ENVIRONMENTAL TECHNOLOGIES
 ENGINEERING DEPARTMENT

ROMIC - SOUTHWEST
 CHANDLER, ARIZONA
 DATE: 11-14-02
 SCALE: NONE

COLUMN 30
PROCESS FLOW DIAGRAM

E-3

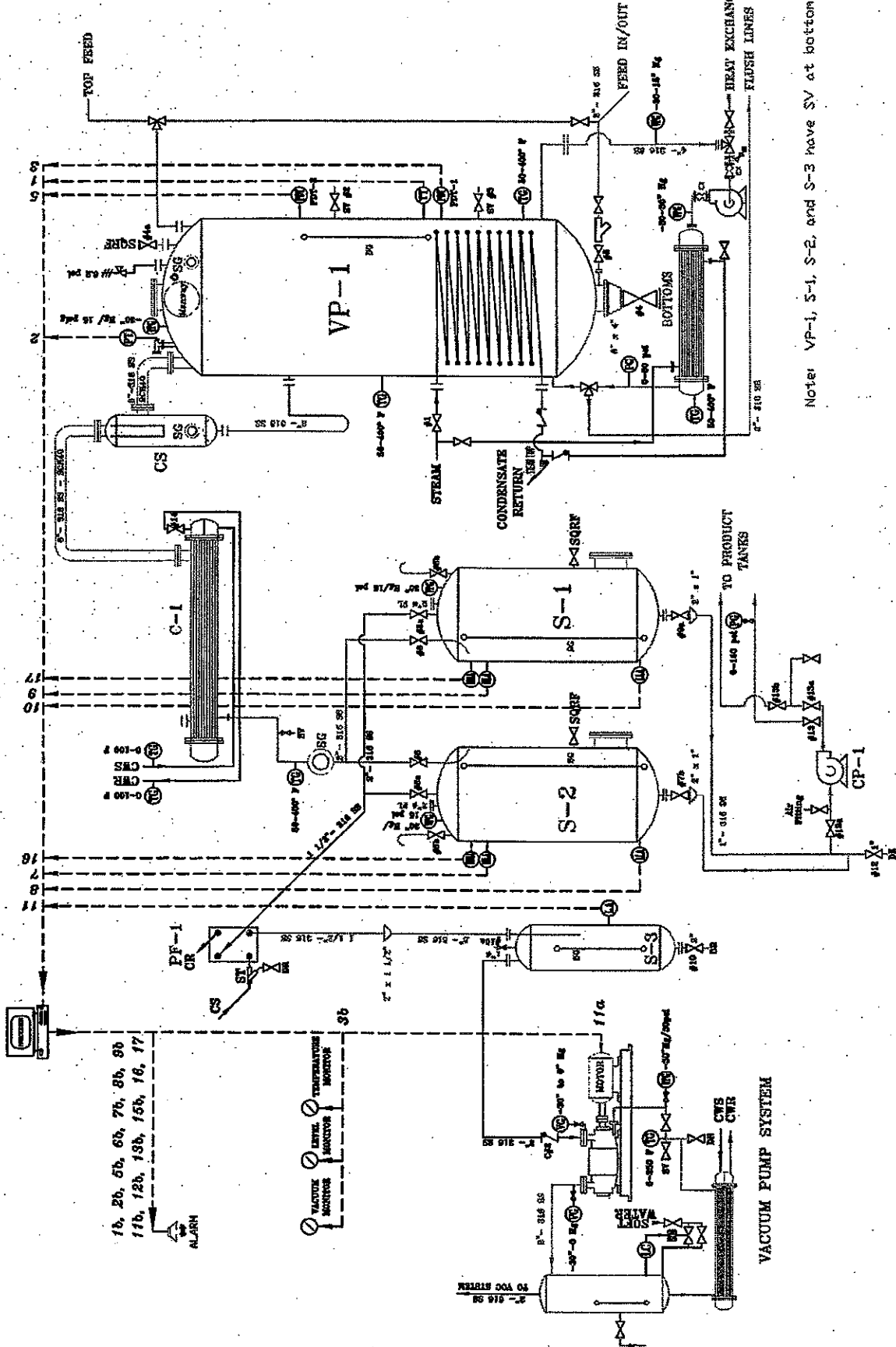
I:\RSW_partB_04_final\E-3 Col30



Note: VP-1, S-1, S-2, and S-3 have SV at bottom of SG.

 ROMIC ENVIRONMENTAL TECHNOLOGIES ENGINEERING DEPARTMENT		DATE: 11-04-02 SCALE: NONE
ROMIC - SOUTHWEST CHANDLER, ARIZONA		VACUUM POT PROCESS FLOW DIAGRAM
REV	DATE	REVISION

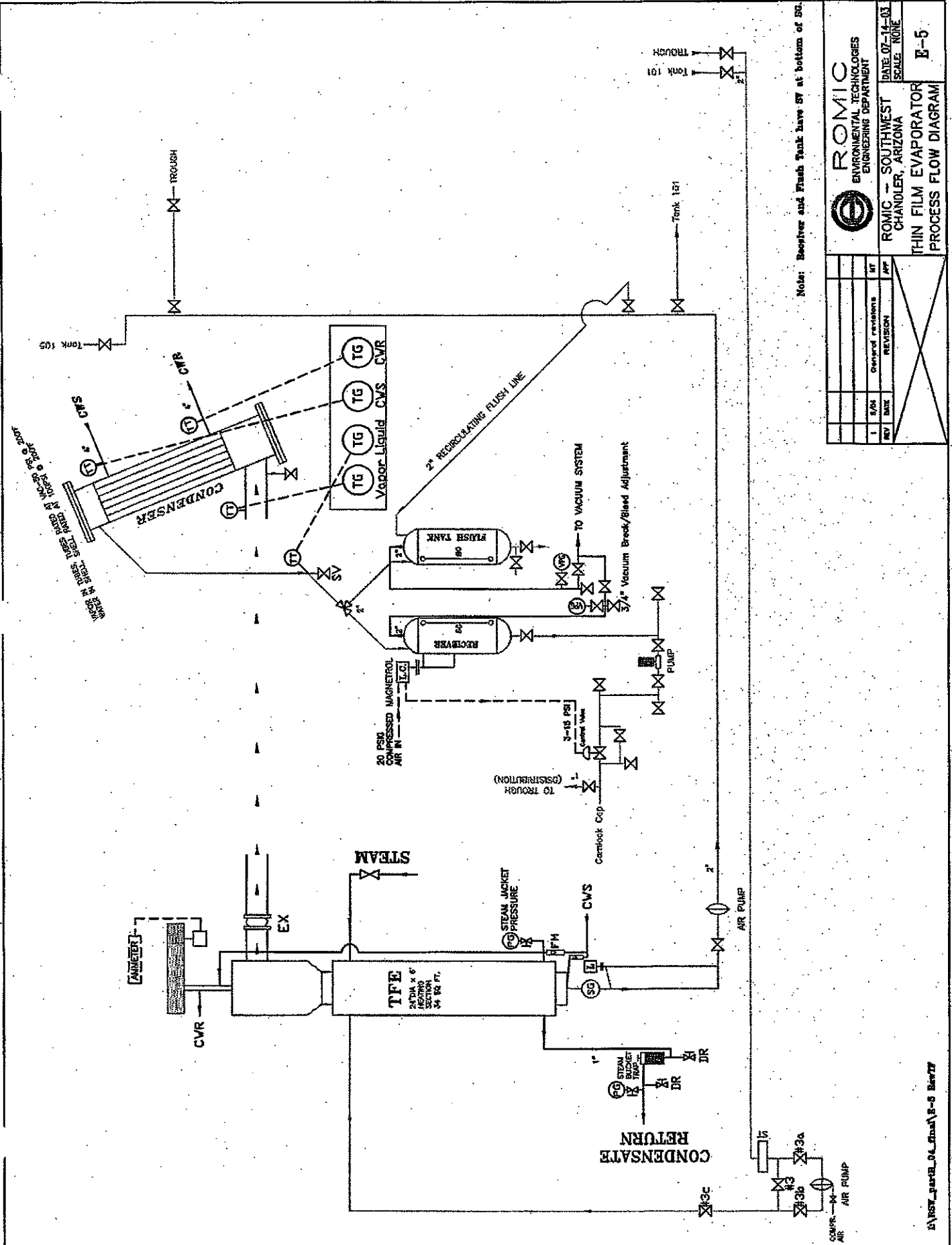

Note: Receiver and Flush Tank have SF at bottom of 50.

		ROMIC ENVIRONMENTAL TECHNOLOGIES ENGINEERING DEPARTMENT	
REV	DATE	REVISION	APP
1	8/24	Original revisions	MT
2			
3			
4			
5			
6			
7			
8			
9			
10			
ROMIC - SOUTHWEST CHANDLER, ARIZONA		DATE 07-14-03 SCALE NONE	
THIN FILM EVAPORATOR PROCESS FLOW DIAGRAM		E-5	

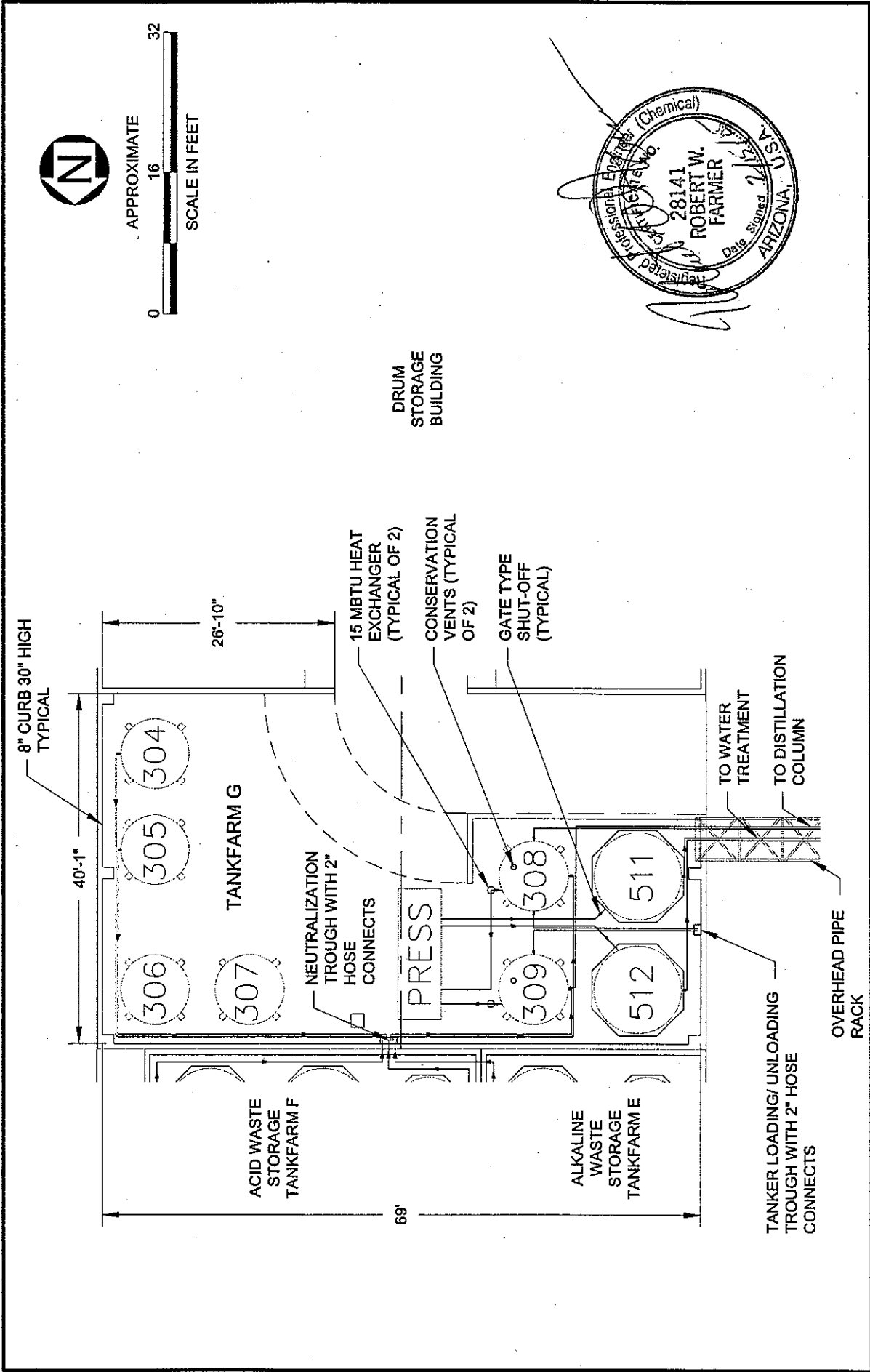

Proposed Tankfarm G
 Romic - Southwest
 Chandler, Arizona

Figure E-6

REFERENCE: BASEMAP PROVIDED BY:

ROMIC
 ENVIRONMENTAL TECHNOLOGIES CORP.
 ROMIC SOUTHWEST, CHANDLER, ARIZONA



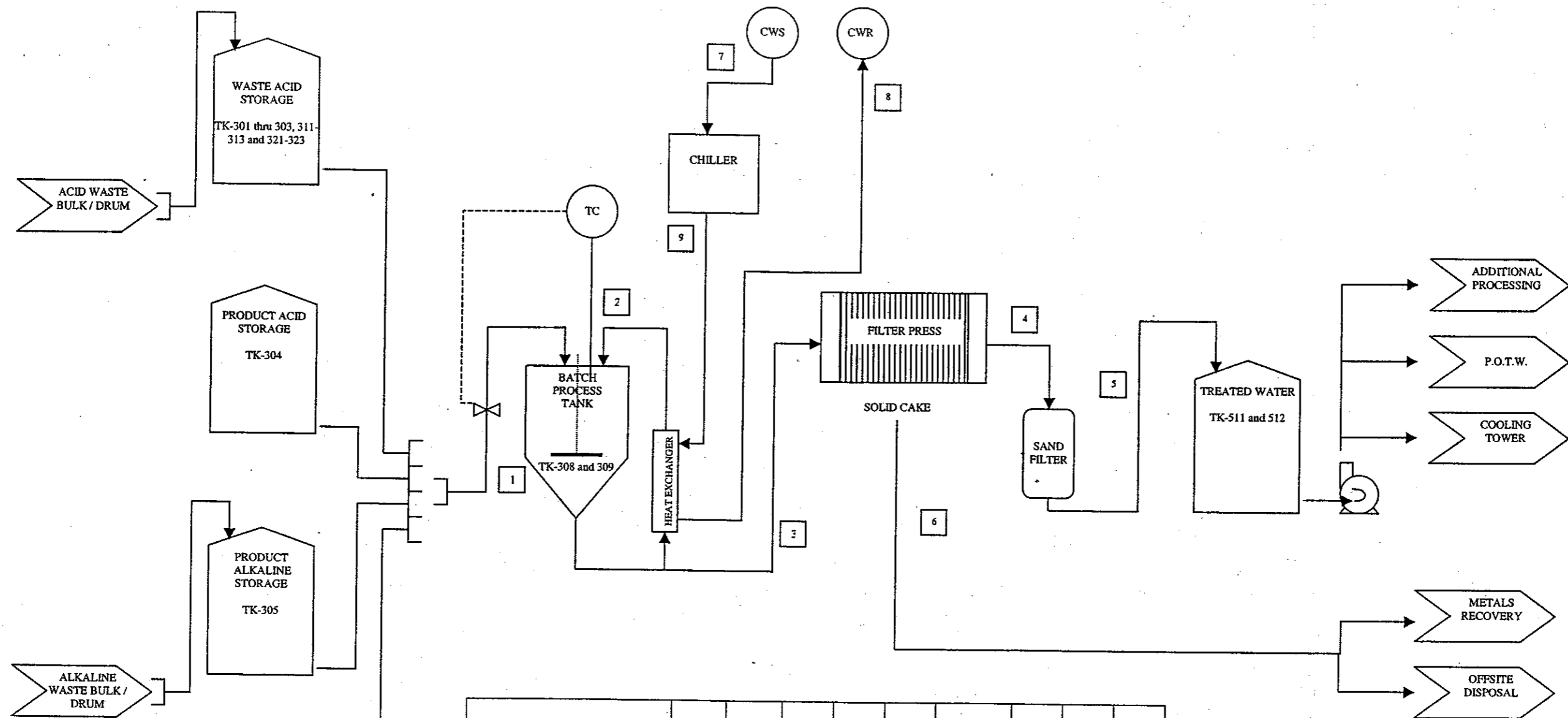

CWS - COOLING WATER SUPPLY
 CWR - COOLING WATER RETURN
 TC - THERMAL COUPLE CONTROL

STREAM NUMBER	1	2	3	4	5	6	7	8	9
PROCESS TANK LOADING									
RECIRCULATION FOR COOLING									
FILTER PRESS FEED									
SAND FILTER FEED									
TREATED WATER									
SOLID CAKE									
COOLING WATER SUPPLY									
COOLING WATER RETURN									
CHILLER SUPPLY									
FLOW UNITS	GPM	GPM	GPM	GPM	GPM	LBS/HR	GPM	GPM	GPM
AVERAGE FLOW	15	75	75	70	70	3000	300	300	300
DESIGN FLOW	100	150	150	150	150	7000	300	300	300
TEMPERATURE, F	AMB	120*	90*	AMB	AMB	AMB	75	100	50**
PRESSURE, PSIG	-	-	200*	100*	-	-	30	25	25
SP. GR. - DENSITY	To 1.84	To 1.84	To 1.84	To 1.10	To 1.10	To 1.60	0.997	0.996	0.996

* MAXIMUM
 ** MINIMUM

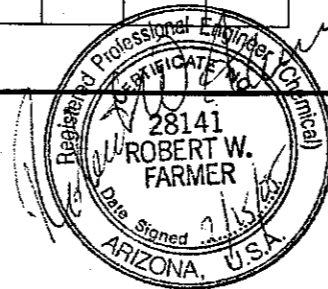

Corrosives Treatment Process Flow Diagram
 Romic - Southwest
 Chandler, Arizona
 Figure E -7

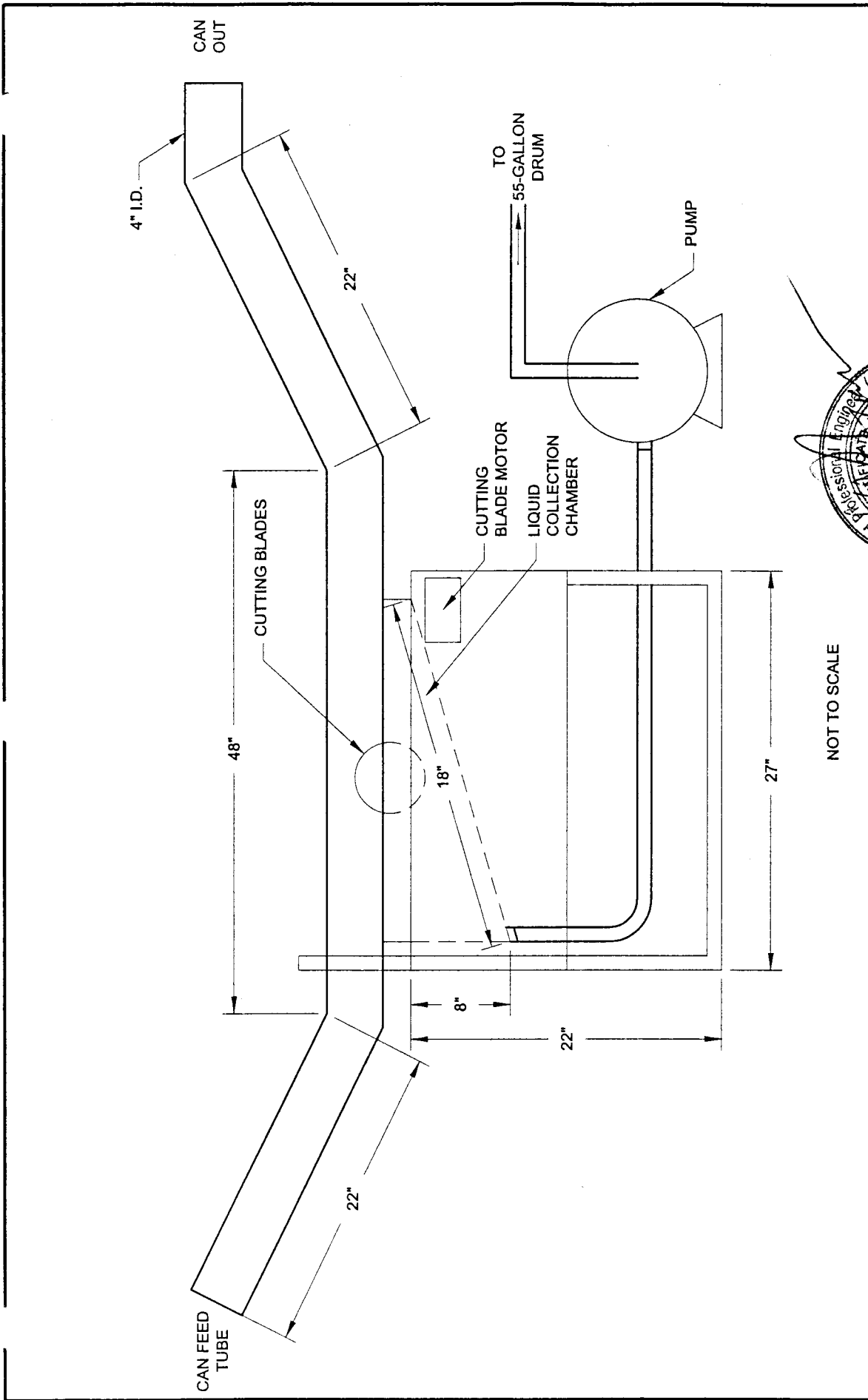

NOT TO SCALE

Aerosol Can Unit
 Romic - Southwest
 Chandler, Arizona

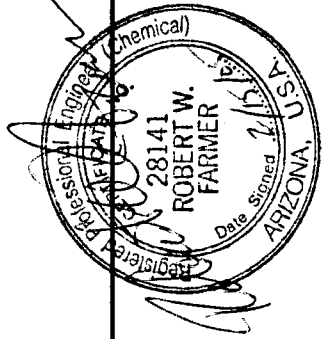
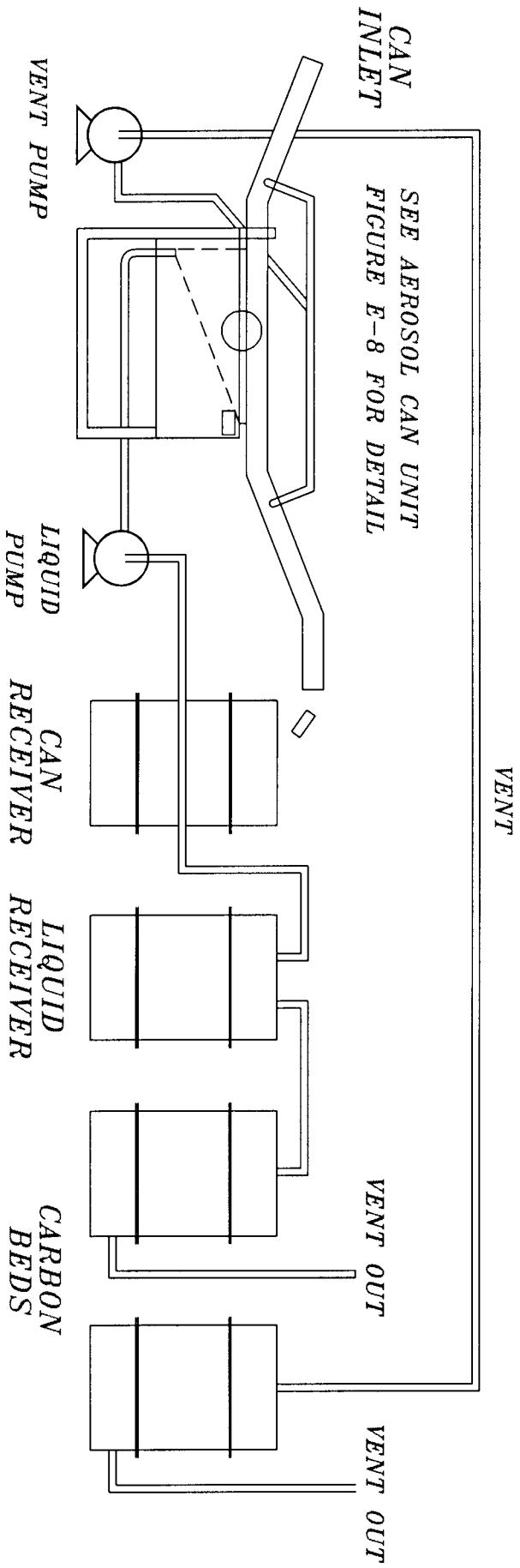

Figure E-8



NOT TO SCALE

REV	DATE	REVISION	APP

ROMIC
ENVIRONMENTAL TECHNOLOGIES
ENGINEERING DEPARTMENT

ROMIC - SOUTHWEST
CHANDLER, ARIZONA
AEROSOL
DEPRESSURIZATION
SYSTEM

DATE: 10-05-05
SCALE: NONE

APPENDIX

7.3 Double End Feed

7.3.1 The function of double end feed is a filtration operation which is utilized with longer than average filter packs or when rapid filling of the filter pack is required. The double end feed connection is located at the follower end of the filter pack. Since the follower must be mobile during cake discharge operations the feed connection may consist of either a flexible hose for low pressure feed (100 psi/7 bar) or a specially designed rigid piping system with three swivel connections for high pressure feed (225 psi/16 bar).

7.4 Air Blow (refer to figure 4-14)

7.4.1 The function of Air blowing of the cake is a post filtration operation that is performed to remove entrained filtrate from the filter cake and residual filtrate from the filter pack porting connections press prior to cake discharge. A pressurized gas, usually compressed air is introduced into the upper filtrate discharge port, forced through the cloth and filter cake in each chamber and out of the diagonally opposed, lower filtrate discharge port (refer to figure 4-15). The removal of excess filtrate will improve cake dryness and help loosen the filter cake for improved cake release.

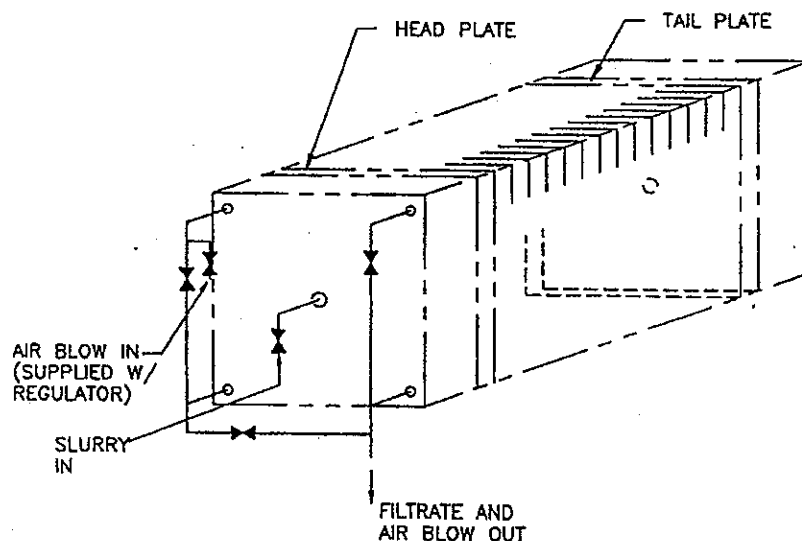
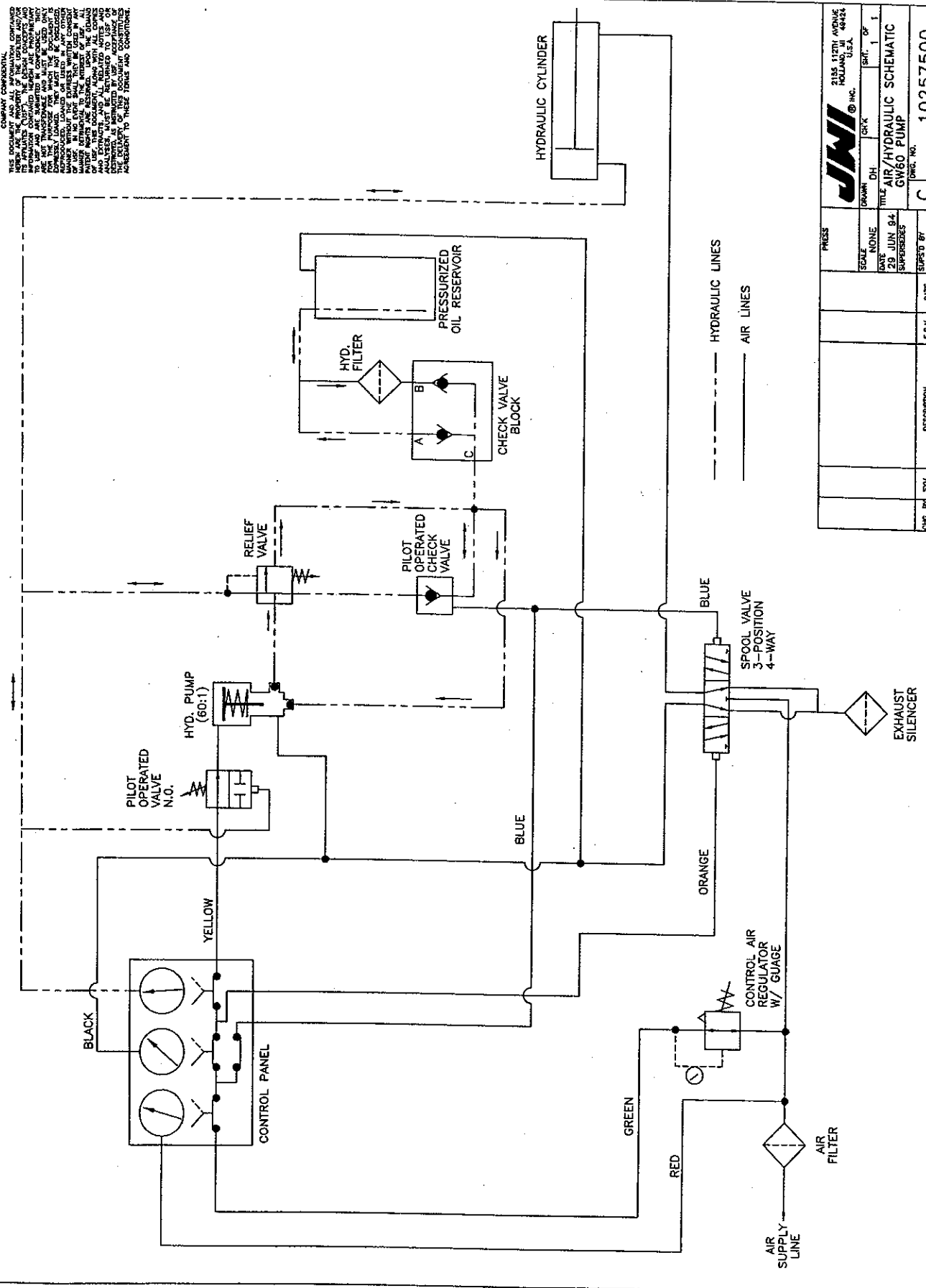

Fig. 4-14. Air Blow Down Manifold Diagram

COMPANY CONFIDENTIAL. THESE DRAWINGS ARE THE PROPERTY OF THE UNITED STATES GOVERNMENT AND ARE LOANED TO YOU BY THE UNITED STATES GOVERNMENT. YOU ARE TO USE THEM ONLY FOR THE PURPOSES FOR WHICH THEY ARE LOANED TO YOU. YOU ARE NOT TO REPRODUCE, TRANSMIT, DISSEMINATE, OR IN ANY MANNER MAKE AVAILABLE TO ANY OTHER PERSON, ORGANIZATION, OR ENTITY, ANY INFORMATION CONTAINED HEREIN WITHOUT THE EXPRESS WRITTEN PERMISSION OF THE UNITED STATES GOVERNMENT. THE DELIVERY OF THIS DOCUMENT CONSTITUTES ACCEPTANCE OF THESE TERMS AND CONDITIONS.



JWI 2155 117TH AVENUE HOLLAND, MI 48424		DRW. NO.	10257500
SCALE	NONE	DATE	29 JUN 94
DRAWN BY	DH	CHK. BY	STL
TITLE	AIR/HYDRAULIC SCHEMATIC		
SUPERSEDES	GW60 PUMP		
SUPD BY	C	DATE	
DESCRIPTION			

FABRICATION OF SHELL-AND-TUBE HEAT EXCHANGERS

Standards

The TEMA² (Tubular Exchanger Manufacturers Association) has published detailed standards for the design and construction of shell-and-tube heat exchangers. The mechanical standard has been divided into three parts representing the following three different classes of heat exchangers:

TEMA Class

1. **Class "R" Exchangers** This type is specified for the generally severe requirements of petroleum and related processing applications. Equipment fabricated per this class is designed for safety and durability under the rigorous service and maintenance conditions in such applications.
2. **Class "C" Exchangers** This is specified for the generally moderate requirements of commercial and general process applications. Equipment fabricated in accordance with this class is designed for the economy and overall compactness consistent with safety and service requirements in such applications.
3. **Class "B" Exchangers** This class is specified for chemical process service. The equipment is designed for the maximum economy and overall compactness consistent with safety and service requirements in such applications.

Fabrication Procedure ^{4,5}

Shells

The shell portion of the heat exchanger is made of either seamless pipe or rolled and welded cylinder. These are fabricated from pipe with nominal pipe diameters up to 12" as given in Table 1. Above 12" and including 24" the actual outside diameter and the nominal pipe diameter are the same. Shells above 24" in diameter are fabricated by rolling and welding steel plates in accordance with the ASME Code Section VIII, Division 1, for Pressure Vessels. Automatic welding is used almost exclusively on the longitudinal seams and also on most of the circumferential seams.

TYPE:

DESIGN OF PROCESS EQUIPMENT

<p>N</p>  <p>FIXED TUBESHEET LIKE "N" STATIONARY HEAD</p>	<p>U</p>  <p>U-TUBE BUNDLE</p>
<p>P</p>  <p>OUTSIDE PACKED FLOATING HEAD</p>	<p>W</p>  <p>EXTERNALLY SEALED FLOATING TUBESHEET</p>

FIG. 1. SHELL-AND-TUBE HEAT EXCHANGERS (Continued)

NOMENCLATURE OF HEAT EXCHANGER COMPONENTS

1. Stationary Head—Channel
2. Stationary Head—Bonnet
3. Stationary Head Flange—Channel or Bonnet
4. Channel Cover
5. Stationary Head Nozzle
6. Stationary Tubesheet
7. Tubes
8. Shell
9. Shell Cover
10. Shell Flange—Stationary Head End
11. Shell Flange—Rear Head End
12. Shell Nozzle
13. Shell Cover Flange
14. Expansion Joint
15. Floating Tubesheet
16. Floating Head Flange
17. Floating Head Cover
18. Floating Head Backing Device
19. Split Shear Ring
20. Slip-on Backing Flange
21. Floating Head Cover—External
22. Floating Tubesheet Skirt
23. Packing Box
24. Packing
25. Packing Gland
26. Lantern Ring
27. Tierods and Spacers
28. Transverse Baffles or Support Plates
29. Impingement Plate
30. Longitudinal Baffle
31. Pass Partition
32. Vent Connection
33. Drain Connection
34. Instrument Connection
35. Support Saddle
36. Lifting Lug
37. Support Bracket
38. Weir
39. Liquid Level Connection

(Courtesy of Tubular Exchanger Manufacturers Association.)

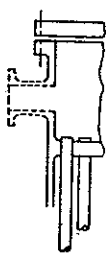
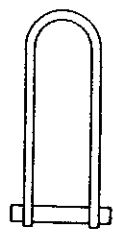
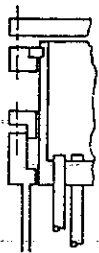
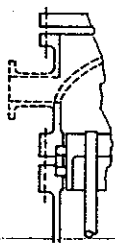
SHELL-AND-TUBE HEAT EXCHANGERS

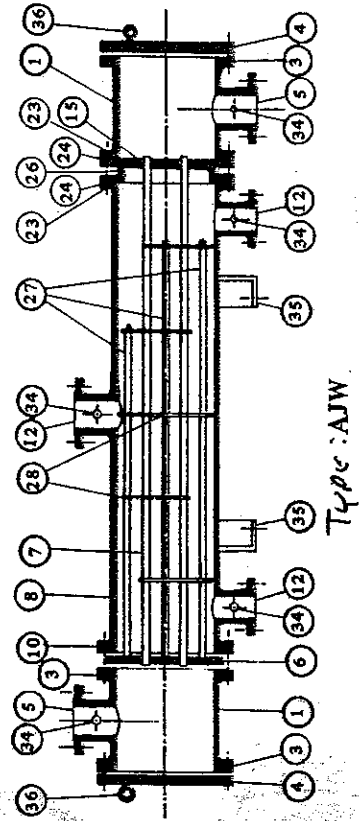
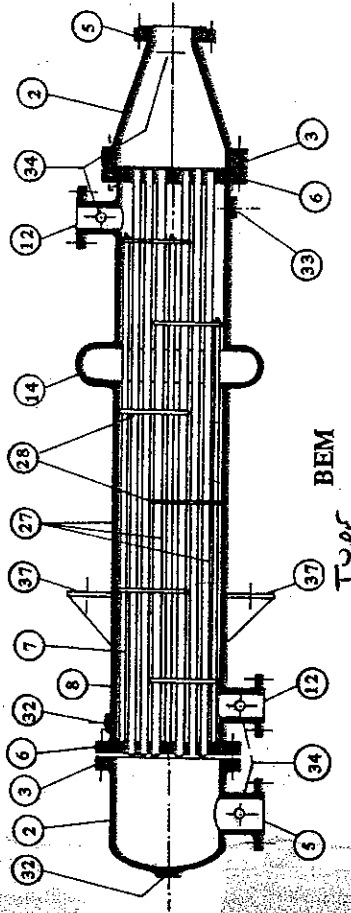
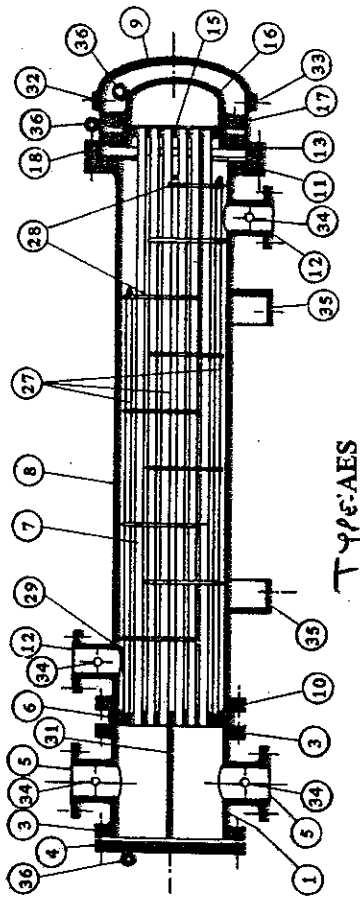

FIG. 2. HEAT EXCHANGER CONSTRUCTION TYPES (Courtesy of Tubular Exchanger Manufacturers Association.)

TYPE:

DESIGN OF PROCESS EQUIPMENT

Figure 2 shows sections of typical exchangers. The tube bundle is made up of tubes, tubesheets and cross baffles. The channel at the front end of the exchanger serves as a header to feed the fluid into the tubes. The floating head at the back end of the tube bundle is the return header. It moves freely with the thermal expansion of the tubes in the bundle.

The shell unit is essentially a cylinder with a bolting flange at each end. The channel bolts to the front flange, and the shell cover bolts to the rear flange. Figure 2 also shows some of the variations available in shell-and-tube designs. Each variation has certain advantages, and also has some disadvantages. The major types of shell-and-tube heat exchangers depending on their mechanical configuration are discussed below.³

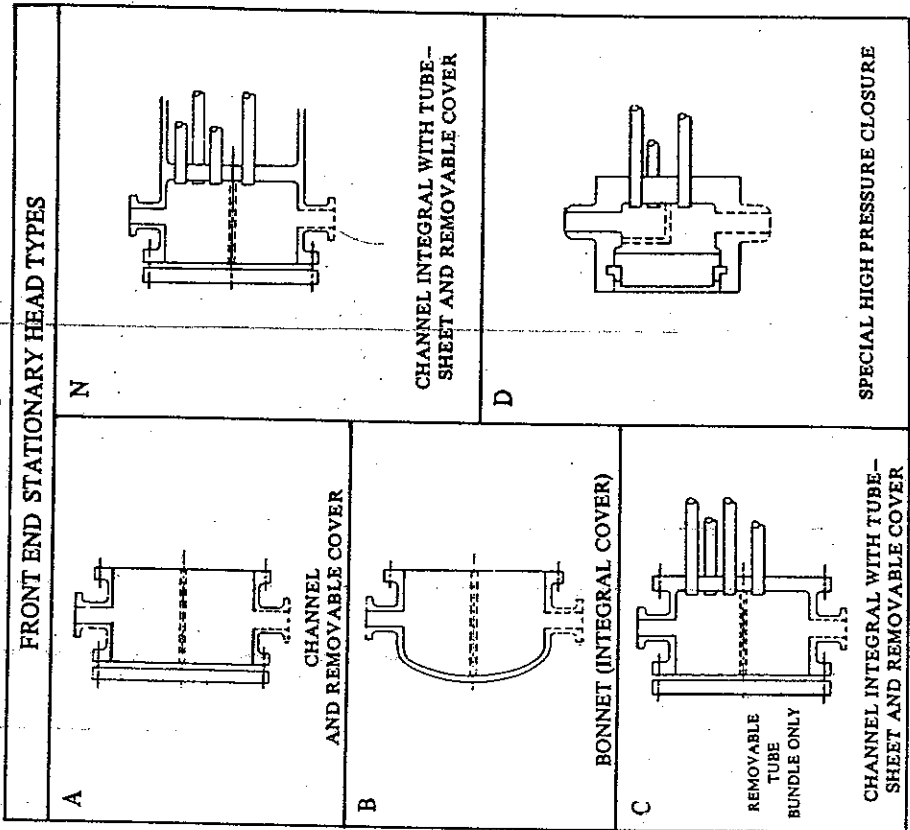

FIG. 1. SHELL-AND-TUBE HEAT EXCHANGERS (Courtesy of Tubular Exchanger Manufacturers Association.)

SHELL-AND-TUBE HEAT EXCHANGERS

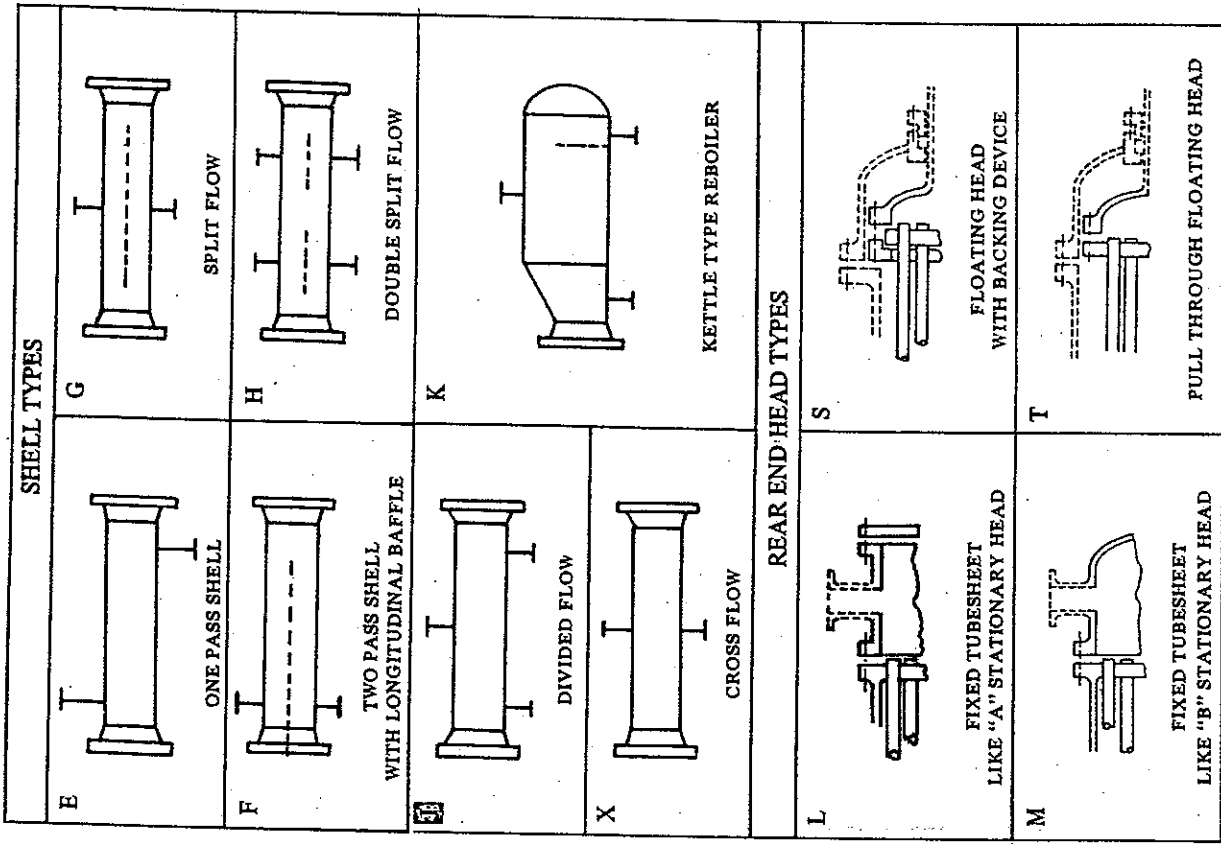

FIG. 1. SHELL-AND-TUBE HEAT EXCHANGERS (Continued) (Courtesy of Tubular Exchanger Manufacturers Association.)

Central Chiller

TSW20 & TSW30 Specifications

Model #	TSW20	TSW30
Cooling capacity (tons) (1)	21	31
Compressors, Qty-nominal tons	2-10	2-15
Steps of unloading	4	4
Evaporator flow, nominal design @ 50°F LWT (GPM)	50	74
Condenser flow, nominal design @ 85°F EWT (GPM)	63	93
Optional P1 process pump HP	5	7.5
Optional P2 chiller pump HP	1.5	2
Nameplate amps 460/3/60 without pumps	32	49
Nameplate amps 460/3/60 with P1 & P2 pumps	43	63
Dimensions, L x W x H without reservoir (inches)	48 x 48 x 66	48 x 48 x 66
Dimensions, L x W x H with 200 gallon reservoir (inches)	103 x 48 x 66	103 x 48 x 66
Dimensions, L x W x H with 425 gallon reservoir (inches)	127 x 48 x 66	127 x 48 x 66
Dimensions, L x W x H with 650 gallon reservoir (inches)	153 x 58 x 66	153 x 58 x 66
Shipping weight (Lbs.)	1600	2000
Shipping weight with 200 gallon reservoir (Lbs.)	3100	3500
Shipping weight with 425 gallon reservoir (Lbs.)	4100	4500
Shipping weight with 650 gallon reservoir (Lbs.)	4600	5000
Evaporator manifold flange connection (inches)	2 NPT	2.5 NPT
Individual condensers flange connection (inches)	1.5 NPT	2 NPT
Optional condenser manifold flange connection (inches)	2 NPT	2.5 NPT

(1) Based on 50°F LWT, 85°F condenser water.

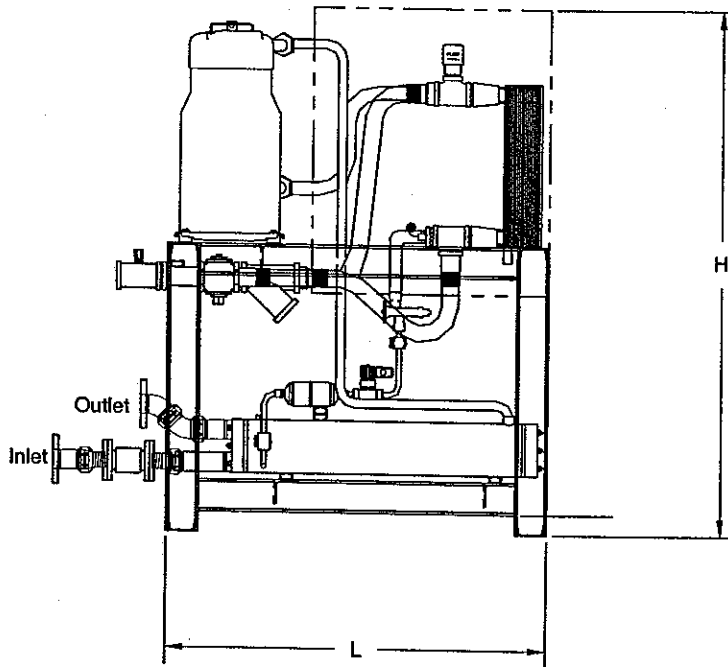

TSW20-30B



Form 3-260.3

7720 N. Lehigh Ave.
 Niles, IL 60714-3491
 Phone: 847-966-2260, ext. 2900
 Toll Free: 888-828-7387

Fax: 847-966-9358
 e-mail: info@thermalcare.com
www.thermalcare.com

Manufacturer reserves the right to change specifications or design without notice or obligation. Thermal Care is a registered trademark of MFRI, Inc.

Central Chiller

TSW50, TSW60 & TSW70 Specifications

Model #	TSW50	TSW60	TSW70
Cooling capacity (tons) (1)	41	51	61
Compressors, Qty-nominal tons	4-10	2-10, 2-15	4-15
Steps of unloading	4	4	4
Evaporator flow, nominal design @ 50 F LWT (GPM)	98	122	146
Condenser flow, nominal design @ 85 F EWT (GPM)	123	153	183
Optional P1 process pump HP	10	10	10
Optional P2 chiller pump HP	2	3	3
Nameplate amps 460/3/60 without pumps	64	80	97
Nameplate amps 460/3/60 with P1 & P2 pumps	81	99	116
Dimensions, L x W x H without reservoir (inches)	84 x 50 x 66	84 x 50 x 66	84 x 50 x 66
Dimensions, L x W x H with 425 gallon reservoir (inches)	132 x 48 x 66	132 x 48 x 66	132 x 48 x 66
Dimensions, L x W x H with 650 gallon reservoir (inches)	158 x 48 x 66	158 x 48 x 66	158 x 48 x 66
Shipping weight (Lbs.)	2500	3400	3900
Shipping weight with 425 gallon reservoir (Lbs.)	5000	5900	6400
Shipping weight with 650 gallon reservoir (Lbs.)	5500	6400	6900
Evaporator manifold flange connection (inches)	2.5 NPT	3 FLG	3 FLG
Individual condensers flange connection (inches)	2.5 NPT	2.5 NPT	3 FLG
Optional condenser Manifold flange connection (inches)	3 FLG	3 FLG	4 FLG

(1) Based on 50 F LWT, 85 F condenser water.

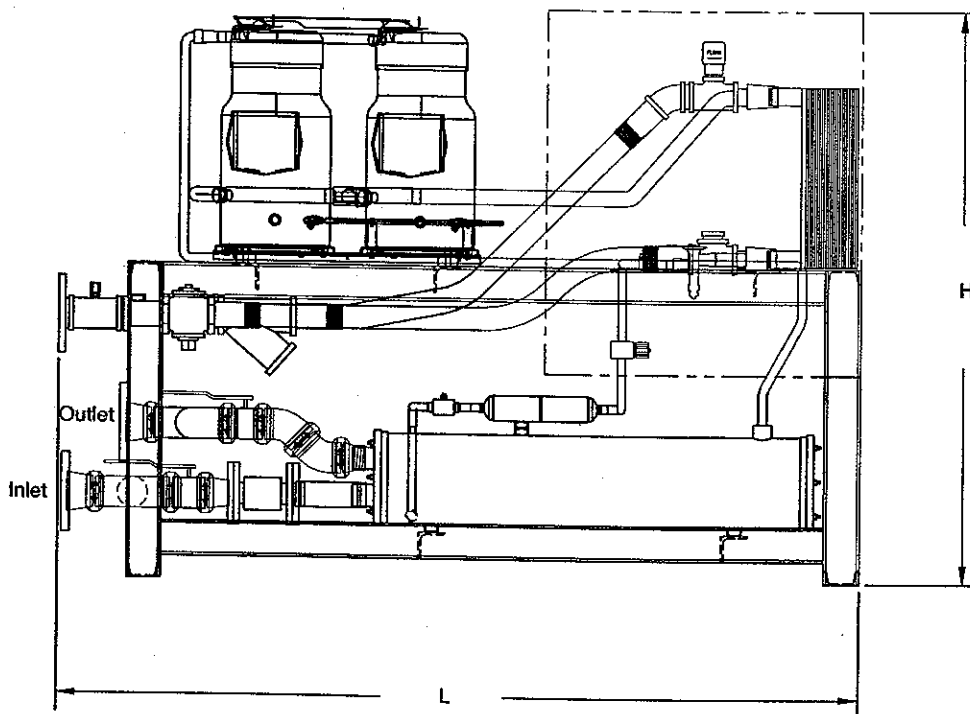

TSW50-70B

THERMAL CARE

Form 3-262.9

7720 N. Lehigh Ave.
Niles, IL 60714-3491
Phone: 847-966-2260, ext. 2900
Toll Free: 888-828-7387

Fax: 847-966-9358
e-mail: info@thermalcare.com
www.thermalcare.com

Manufacturer reserves the right to change specifications or design without notice or obligation. Thermal Care is a registered trademark of MFRI, Inc.

Central Chiller

TSW90 & TSW100 Specifications

Model #	TSW90	TSW100
Cooling capacity (tons) (1)	81	91
Compressors, Qty-nominal tons	2-10, 4-15	6-15
Steps of unloading	6	6
Evaporator flow, nominal design @ 50 F LWT (GPM)	195	220
Condenser flow, nominal design @ 85 F EWT (GPM)	243	273
Optional P1 process pump HP	15	15
Optional P2 chiller pump HP	3	3
Nameplate amps 460/3/60 without pumps	129	145
Nameplate amps 460/3/60 with P1 & P2 pumps	155	171
Dimensions, L x W x H without reservoir (inches)	96 x 50 x 66	96 x 50 x 66
Dimensions, L x W x H with 650 gallon reservoir (inches)	170 x 48 x 66	170 x 48 x 66
Shipping weight (Lbs.)	4250	4900
Shipping weight with 650 gallon reservoir (Lbs.)	7250	7900
Evaporator manifold flange connection (inches)	4	4
Individual condensers flange connection (inches)	3	4
Optional condenser manifold flange connection (inches)	4	4

(1) Based on 50 F LWT, 85 F condenser water.

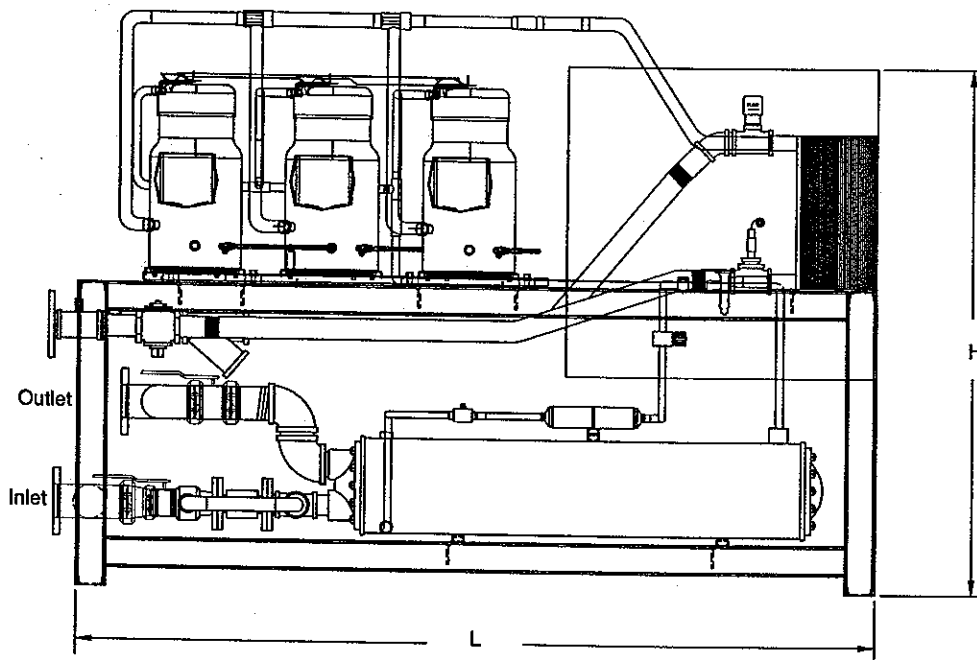

Form 3-261.3

7720 N. Lehigh Ave.
 Niles, IL 60714-3491
 Phone: 847-966-2260, ext. 2900
 Toll Free: 888-828-7387

Fax: 847-966-9358
 e-mail: info@thermalcare.com
www.thermalcare.com

Manufacturer reserves the right to change specifications or design without notice or obligation. Thermal Care is a registered trademark of MFRI, Inc.