

US EPA ARCHIVE DOCUMENT

Protocol # 01-1A

Protocol for Residual Self-Sanitizing Activity of  
Dried Chemical Residues on Hard, Non-Porous  
Surfaces

## Title: Protocol for Residual Self-Sanitizing Activity of Dried Chemical Residues on Hard Nonporous Surfaces

### Purpose:

To determine the residual sanitizing efficacy of antimicrobial products after application to inanimate, nonporous, non-food contact hard surfaces.

### Scope:

This method applies to products intended for use on inanimate, nonporous, non-food contact hard surfaces for the evaluation of residual antimicrobial efficacy. These products may be sprayed or applied by other means as specified. This method is to be performed by personnel trained in the procedures. This SOP describes the microorganisms, equipment, data collection and procedures for evaluating a residual sanitizer for non-food contact surfaces. This method includes a regimen by which each treated surface undergoes specific wear exposures to demonstrate residual efficacy of the test product.

### Procedure:

#### I. Microorganisms

##### A. Bacteria

1. *Staphylococcus aureus* ATCC#6538
2. *Klebsiella pneumoniae* ATCC#4352, or  
*Enterobacter aerogenes* ATCC#13048
3. Other microorganisms as desired

#### II. Culture Media

- A. Lethen Broth or appropriate neutralizing media, 30 mL in wide-mouth 250-ml plastic autoclavable bottles
- B. Lethen Agar or appropriate growth media
- C. AOAC Nutrient Broth or appropriate subculture media, 10 mL per tube

#### III. Reagents

- A. 70% (vol/vol) ethanol for flaming forceps
- B. Absolute ethanol for decontaminating wear surface
- C. Triton X-100. 0.01% vol/vol solution, prepared on day of test and filter-sterilized, 0.22 um
- D. Distilled water, 9 mL blanks and 9.9 mL blanks, sterilized in autoclave or by filtration
- E. Heat-inactivated serum (Sigma; horse, sheep, or cow), sterile

#### IV. Equipment

A. Test surfaces; non-porous, pre-cleaned, 1 inch x 1 inch. Surfaces types can include but are limited to:

1. Glass, non-frosted microscope slides
2. Mirrored stainless steel
3. Polycarbonate plastic, ¼ inch thick
4. Spacers of appropriate material and thickness for holding test surfaces on the abrasion tester during wear

B. Glass petri dishes lined with 1-2 layers of Whatman No. 2 paper, sterile

C. Plastic petri dishes for plating, sterile

D. Plastic petri dishes, inverted and lined with 1-2 layers of Whatman No. 2 paper, sterile

E. Pipets

1. Sterile disposable 2.2 mL, graduated in 0.1 mL
2. Sterile disposable 5 mL

F. Micropipetor, 10-microliter range, with sterile tips

G. Inoculating loops/needles

1. 10-microliter inoculating loops, sterile
2. Inoculating needle, plastic, bent at approximately 45 degree angle, sterile

H. Forceps

I. Timer with minute and second intervals

J. Preval<sup>R</sup> sprayers fitted to a separate bottle (for applying Triton solution to control surfaces and for moistening the wear cloth) – Decontaminated by rinsing with alcohol then rinsing thoroughly (at least three times) with sterile distilled water.

K. Vortex mixer

L. Sonicator waterbath

M. Orbital shaker

N. Incubators

1.  $35 \pm 2^{\circ}\text{C}$  ( $30 \pm 2^{\circ}\text{C}$  for *Enterobacter*)
  2. Other temperatures for additional other microorganisms as required for their optimal growth
- O. Bunsen burner
- P. Analytical balances
- Q. Thermometer for room temperature measurements
- R. Hygrometer for relative humidity measurements
- S. Gardco Washability and Wear Tester (Model D10V, Cat. #WA-2153, Paul N. Gardner Co., Inc., Pompano Beach, FL)
1. Abrasion boat (Cat. #WA-2225) fitted with 2-inch strips of 1/8-inch polyurethane foam (FoamWipe wiper, VWR Cat. #TW-TX 704). The total weight of the abrasion boat with foam, cloth and two additional weights (Gardco Cat. #WA-2227 and #WA-2210/P01) is  $1084 \pm 0.2$  g.
  2. Foam liners are covered with 2-inch strips of cotton cloth (TexWipe Clean Cotton Wipers, VWR Cat. #TW-TX 309)

#### V. Preparation

- A. Media and reagent preparation
1. Prepare and store microbiological media/reagents using established procedures.
- B. Subculture and inoculum preparation
1. Store and maintain ATCC cultures according to established procedures.
  2. Make at least three consecutive daily transfers using a 10-microliter loop in 10 mL of AOAC Nutrient Broth or appropriate growth medium. Incubations are at  $35 \pm 2^{\circ}\text{C}$  (except *E. aerogenes* at  $30 \pm 2^{\circ}\text{C}$ ).
  3. Incubate the **final test culture** for 18-24 hours. Mix for 3-4 seconds on a vortex mixer and let stand  $15 \pm 1$  minutes. Decant or pipet off the upper two-thirds volume of the culture and transfer it to a sterile tube. Add a volume of serum to equal 5% organic soil load. Vortex again and let stand  $15 \pm 1$  minutes.
    - a) For the **initial inoculation**, vortex for 3-4 seconds a 48-54 hour culture and let stand for  $15 \pm 1$  minutes. Make two 0.1 mL to 9.9 mL serial dilutions in sterile distilled water and let stand for  $15 \pm 1$  minutes. Apply a 10 microliter aliquot of this suspension to the test surfaces, spread to within 1/8 inch of the edge with a bent inoculating needle, and dry uncovered at  $35 \pm 2^{\circ}\text{C}$  for 30-35 minutes, or until visibly dry.

b) For the culture used in the **24-hour reinoculations**, vortex an 18-24 hour culture and let stand for  $15 \pm 1$  minutes. Make two 0.1 mL to 9.9 mL serial dilutions and one final dilution of 5.0 mL to  $5.0 \pm 0.2$  mL in sterile distilled water. Add a volume of serum to equal 5% organic soil load. (Example: 0.5 mL serum + 9.5 mL bacteria suspension.) Vortex again and let stand  $15 \pm 1$  minutes.

c) Fresh 18-24 hour cultures will be prepared for the 24-hour reinoculations to ensure that no culture will be allowed to stand with organic soil load for longer than eight hours. A fresh 18-24 hour culture is also used for the final test culture, as described above.

4. The concentration of the initial inoculation and a representative 24-hour reinoculation will be determined by serially diluting in 9 mL blanks of sterile distilled water and plating  $1 \pm 0.1$  mL aliquots to duplicate agar medium plates. The plates are to be incubated at  $35 \pm 2^\circ\text{C}$  (except *E. aerogenes* at  $30 \pm 2^\circ\text{C}$ ) for 48-54 hours.

5. The concentration of the final test culture will be determined by serially diluting in  $9.0 \pm 0.1$  mL blanks of sterile distilled water and plating  $1 \pm 0.1$  mL aliquots to duplicate agar medium plates. The plates are to be incubated at  $35 \pm 2^\circ\text{C}$  (except *E. aerogenes* at  $30 \pm 2^\circ\text{C}$ ) for 48-54 hours.

#### C. Test surface preparation

1. Prepare surfaces for pre-cleaning by removing the adhesive protective backing, if applicable. Clean all plastic surfaces in mild detergent, then alcohol, and rinse thoroughly in distilled water and allow to air dry. Clean metal and glass surfaces by rinsing in alcohol then distilled water and allow to air dry. All handling of surfaces should be done wearing gloves and once cleaned, all test surfaces should be handled only with forceps.

2. Decontaminate glass, metal and plastic surfaces by immersing in absolute ethanol, wiping and allowing to air dry. Transfer to individual plastic petri dishes lined with 1-2 layers of Whatman No. 2 paper. Allow all surfaces to completely dry prior to use, approximately one day. Check for the absence of inhibitory residues.

3. Apply the test product to replicate test surfaces according to the product's Directions For Use. Apply the product to the test surfaces on a clean dry surface such as a lab bench lined with paper, assuring that the surface are level when drying. Allow the surfaces to dry at room temperature and 45-55% Relative Humidity for at least 3.0 hours or until completely dry.

4. Apply 0.01% Triton X-100 sterile solution to replicate control surfaces of each surface type. This solution is to be sprayed from a Preval spray bottle according to the test product's Directions for Use or until the surfaces are completely wet. The control surfaces will be allowed to dry under the same conditions as the test surfaces.

5. Prepare duplicate sterility control surfaces by applying the initial inoculation, applying the product as described in section V.C.3. Transfer the surfaces to sterile growth medium and incubate as appropriate for the test organism. Record

presence or absence of growth on these surfaces to ensure sterility of the test surfaces.

## VI. Test Method

### A. "Wear" and reinoculation of the test and control surfaces

1. Following the initial inoculation of test organism to each of the surfaces as described above in section V.B.2(a), apply the test product or control solution and allow to dry, sections V.C.3 and V.C.4.
2. Set the abrasion tester to a speed of 2.25 to 2.5 for a total surface contact time of approximately 4-5 seconds, for one complete cycle. One pass on the abrasion tester should provide a contact time with the surfaces of approximately 2 seconds. A cycle equals one pass to the left and a return pass to the right.
3. The treated surfaces will undergo a wear and reinoculation regimen, which will take place over 24 hours at room temperature and 45-55% R.H. Decontaminate the surface holder on the Gardner apparatus with absolute ethanol between each set of surface wears to prevent carryover contamination. Allow the alcohol to completely evaporate before proceeding. Replace the foam liner and the cotton cloth between each set of surface wears. (One "set" of surfaces is made up of two 1 x 1 inch test surfaces.) Wait at least 15 minutes after each wear until the next reinoculation.

Allow at least a 30 minute drying time at ambient temperature after each reinoculation, prior to initiation of the sanitizer test.

4. For the wet-wears, which alternate with the dry-wears, prepare the cloth for the wet-wear cycles by attaching to the abrasion boat assembly then spraying the cloth with sterile distilled water, using a Preval sprayer, from a distance of  $75 \pm 1$  cm for not more than one second. Immediately attach the moistened abrasion boat to the abrasion tester apparatus.
5. Record room temperature and R.H. at appropriate intervals such as time of product application, end of drying period, beginning and end of daily wear regimen.

Record the weight of the fully-assembled abrasion boat prior to the wear and reinoculation procedure.

See the following table for an overview of an example wear and reinoculation procedure, which can include at least 12 wear cycles (or 48 passes over the surfaces) and 5 reinoculations (or the registrant may provide a consumer usage habit survey to better define the worst case usage and modify the wearing protocol accordingly). The period between product application and the initiation of the sanitizer test should be at least 24 hours.

<b>“Wear” and Reinoculation Procedure</b>
1. Initial inoculation with test organism
2. Apply test product
3. Wear cycle** with dry cloth (wear #1)
4. Reinoculation with test organism
5. Wear cycle with moist cloth (wear #2)
6. Reinoculation with test organism
7. Wear cycle with dry cloth (wear #3)
8. Reinoculation with test organism
----- End of first day -----
9. Wear cycle with moist cloth (wear #4)
10. Reinoculation with test organism
11. Wear cycle with dry cloth (wear #5)
12. Reinoculation with test organism
13. Wear cycle with moist cloth (wear # 6)
14. Repeat until 12 wear cycles are completed.
15. Sanitizer test performed at least 24 hours after application of the test product

\*\* A cycle equals one forward pass plus one return pass of the abrasion boat.

6. The initial inoculation, reinoculations, and the final inoculation of test organism will be performed by applying a 10-microliter aliquot to the test surface. The aliquot will immediately be spread with a sterile inoculating needle bent to approximately a 45° angle. The inoculum will be gently spread to within 1/8 inch of the surface edge.

**B. Sanitizer test**

1. With the final test culture, inoculate the first test surface at zero time with  $10 \pm 1$  microliters. Begin the inoculation about 5 seconds before the minute hand reaches the minute mark. Spread the aliquot over the surface so that it is completed at exactly the minute mark. Begin the inoculation of the second test surface similarly at given intervals until all the test surfaces have been inoculated.

2. At exactly 5 minutes (or appropriate contact time depending on test product), use alcohol-flamed forceps to transfer the test surfaces to 30 mL of neutralizer broth in a wide-mouth plastic bottle. Repeat until all the test surfaces and control surfaces have been completed.

3. Sonicate the samples for  $20 \pm 2$  seconds in a sonicating waterbath. Then agitate the samples on an orbital shaker for 3-4 minutes at 250 rpm.

4. Serially dilute the control samples in  $9.0 \pm 0.1$  mL of sterile distilled water. Prepare duplicate pour plates of  $10^{-2}$  to  $10^{-4}$ . Plate all samples within approximately 30 minutes of their transfer to the neutralizer broth. The control plates must have a minimum of  $1 \times 10^4$  bacteria/carrier for a valid test.

5. Serially dilute the test samples in  $9.0 \pm 0.1$  mL of sterile distilled water. Prepare duplicate pour plates of  $10^0$  to  $10^{-2}$ . Plate all samples within approximately 30 minutes of their transfer to the neutralizer broth.



6. Incubate all plates at  $35 \pm 2^\circ\text{C}$  (except *E. aerogenes* at  $30 \pm 2^\circ\text{C}$ ) for 48-54 hours.

7. Count plates containing between 30 and 300 CFU and record. Determine the number of surviving organisms per mL of each Control sample by multiplying the number of recovered test organisms by the dilution factor and then multiply this number by 30 (to account for broth volume) to determine the total number of organisms per Control surface. Similarly determine the total number of surviving organisms per test sample surface.

8. Calculate the Percent Reduction in Counts as follows:

Determine the geometric mean of the number of organisms surviving on four control surfaces or four test surfaces by the following equation:

$$\text{Geometric Mean} = \frac{\text{Antilog}(\text{Log}_{10} X_1 + \text{Log}_{10} X_2 + \text{Log}_{10} X_3 + \text{Log}_{10} X_4)}{4}$$

where X equals the number of organisms surviving per carrier.

Determine percent reduction of organisms surviving on test surfaces over organisms surviving on parallel control surfaces as follows:

$$\% \text{ Reduction} = \frac{\text{Geometric mean of control survivors} - \text{geometric mean of test survivors}}{\text{Geometric mean of control survivors}} \times 100$$

NOTE: To be defined as a sanitizer, the test product on the hard inanimate surface must reduce the total number of organisms by at least 99.9% on the surface within a 5 minute period.

### C. Neutralization confirmation

1. Neutralization efficacy of the neutralizer broth can be conducted prior to or concurrently with testing. Neutralization efficacy will be confirmed for each organism and each surface tested.
2. Treat duplicate test surfaces with the test product according to the product Directions for Use. Allow to air dry. Similarly apply Triton X-100 solution to duplicate surfaces.
3. [Adjust the optical density of an 18-24 hour test culture so that approximately 1000-2000 organisms are added to each bottle when challenging the neutralizer. The neutralizer volume is 30 mL.]

Using sterile forceps, at timed intervals transfer each product-treated surface to individual bottles containing 30 mL of the sterile neutralizer broth. At timed intervals after each surface addition, add a volume of the bacterial suspension to deliver approximately 1000-2000 organisms. Mix. At  $5 \pm 1$  minutes, remove  $1.0 \pm 0.1$  mL from each bottle and pour plate with neutralizer agar.

D. Read plates after 48-54 hours of incubation at  $35 \pm 2^\circ\text{C}$  (*E. aerogenes* at  $30 \pm 2^\circ\text{C}$ ). Recovery of colonies on the plate indicates the test product as applied to the test surface has been adequately neutralized by the neutralizer broth. Recoveries from the test suspensions should be similar to the counts recovered from the Triton-treated control suspensions. (Recover  $\geq 70\%$  of the counts observed in the Triton control.) No colony growth indicates the test product was not neutralized and the test should be repeated with an effective neutralization system.

#### VII. Label claims supported by Protocol

- A. [This product] kills 99.9% of bacteria for 24 hours.\*\*
- B. [This product] sanitizes for 24 hours.\*\*
- C. [This product] kills 99.9% of odor causing bacteria for 24 hours.\*\*
- D. [This product] keeps killing 99.9% of bacteria for 24 hours.\*\*
- E. [This product] continues to kill 99.9% of bacteria for 24 hours.\*\*
- F. [This product] also kills 99.9% of bacteria for 24 hours.\*\*\

#### Organisms

\*\*Kills 99.9% of bacteria for 24 hours: Staphylococcus aureus [staph], Escherichia coli 0157:H7 [E. coli], Salmonella choleraesuis [salmonella], or Klebsiella pneumoniae

---

#### References:

Schneider, B.A. 1982. "Subseries 91-A: Public Health Uses" in Pesticide Assessment Guidelines Subdivision G: Product Performance. EPA Document 500/9-82-026.

Product Performance Test Guidelines. OPPTS 810.2100. Products for use on hard surfaces – Basic efficacy data requirements. January, 1997. EPA Document 712-C-97-056.

Standard Test Method for Efficacy of Sanitizers Recommended for Inanimate Non-Food Contact Surfaces (ASTM Designation: E 1153) in ASTM Standards on Materials and Environmental Microbiology.

## Abrasion Tester

## **Title: Abrasion Tester – Set-Up and Operation**

### **Purpose:**

This SOP defines the proper set-up and operation of the GardCo Washability and Wear Tester (Model D10V, Cat #WA-2153, Paul N. Gardner Co., Inc., Pompano Beach, FL). (Abrasion Tester)

### **Scope:**

The procedures outlined are to be followed by the responsible operator(s) to assure accurate set-up and operation of this equipment. This is an SOP which explains the procedure to be used to set-up and operate this piece of equipment. This set-up and operation method outlined applies to GLP test protocols for use on inanimate, nonporous, non-food contact surfaces for the evaluation of residual antimicrobial efficacy.

### **Procedure:**

#### **I. Equipment**

##### **A. GardCo Washability and Wear Tester Equipment**

1. GardCo Washability and Wear Tester (Model D10V, Cat. #WA-2153, Paul N. Gardner Co., Inc., Pompano Beach, FL)
2. Weights
  - a) One 1 pound (453.6 g) Friction Boat Auxiliary Weight (Cat. #WA-2227, Paul N. Gardner Co., Inc., Pompano Beach, FL)
  - b) One 0.45 pound (206.3 g) Brush Box Removable Weight (Cat. #WA-2210/PO1, Paul N. Gardner Co., Inc., Pompano Beach, FL)
  - c) Weigh individual weights to ensure correct weight amount.
3. Abrasion Boat (Cat. #WA-2225, Paul N. Gardner Co., Inc., Pompano Beach, FL)
4. Standard Test Sample Tray, 18-in (Cat. #WA-2205, Paul N. Gardner Co., Inc., Pompano Beach, FL)
5. Test Sample Tray plate (to be put inside test sample tray,)
  - a) Standard Glass Plate, 17.75-in (Cat. # WA-2235, Paul N. Gardner Co., Inc., Pompano Beach, FL)

OR

  - b) Polycarbonate Plate (Clear, 7-in x 17.5-in x 0.25-in)

##### **B. Wipes**

1. 1/8-in Polyurethane Foam Liners cut into 2-in strops (FoamWipe Wiper, VWR Cat. # TW-TX 704)
2. Cotton Cloth Wipes cut into 2-in strips (TexWipe Clean Cotton Wipers, VWR Cat. # TW-TX 309)

#### C. Test Carriers and Spacers

1. Ten 1-in x 1-in Test Surface carriers Test Surface Examples
  - a) Polycarbonate: Clear, 1/4 –in thick. (Example: Colorless, Cyrolon Polycarbonate Sheet)
  - b) Glass, Non-Frosted Microscope Slides (Example: Coming Brand Microscope Slides, Plain; Corning No. 2947-75x25; VWR Cat. # 48300-130. Cut into 1-inch x 1-in portions.)
  - c) Mirrored Stainless Steel (Stainless Steel/Mirrored Finish. Specification: Aisi Type 304 No. 8 Finished according to ASTM 240, A480.)

#### D. Test Surface Spacers

1. Three 4-in x 4-in Spacers of Desired Test Surface (Ensure that spacers are same thickness as test surfaces carriers.)
2. At least One 1-in x 1-in Spacers of Desired Test Surface (Ensure that spacers are same thickness as test surfaces carriers.)
3. **Note:** For Glass, use thick (minimum 1/4-in) glass for spacers. (This allows glass to be clamped without breaking.) Additional uncut microscope slides will also be needed.

#### E. Miscellaneous

1. Three 3-in “C” Clamps
2. Stopwatch (calibrated by NIST or equivalent)
3. Ethanol

### II. Abrasion Tester Set-up

- A. Set up GardCo Abrasion and Washability Tester as indicated in Owner/Operation Manual from Gardco. (In general, always refer to Owner/operation manual for detailed instructions for operation.)
- B. Follow for Abrasion Tester Qualification and Maintenance
- C. Remove Abrasion Tester Moving Arm and Re-attach in second (middle) Position.

(Please see attached diagram: ATSU\_without\_AB.pdf)

D. Place Test Sample tray containing either glass or Polycarbonate plate on flat surface in front of Abrasion Tester, approximately centered.

E. Set Cycle Number

1. Ensure that Abrasion Tester is in "Off" Position
2. Press black Index button on counter and hold.
3. Open Counter Panel
4. Set to Desired Cycle Number. (One cycle = two passes)
  - a) Residual Self-Sanitizing Protocol: Cycle Number = 1 (one cycle = two passes)
5. Close Panel
6. Turn "On" Abrasion Tester

F. Set variable Speed Dial to speed of 2.25 to 2.5 for one complete cycle of  $10 \pm 0.5$  seconds (2 seconds of contact with test surface carriers per pass).

1. Measure cycle speed with calibrated stopwatch to ensure correct speed.

### III. Spacer Set-up

A. Test Surface Preparation

1. Prepare test surface carriers and test surface spacers by removing the adhesive protective backing, if applicable.
2. Clean plastic (Example: Polycarbonate) test surface types in mild detergent, rinse thoroughly in distilled water and allow to air dry.
3. Pre-clean all test surface carriers and spacers by wiping with alcohol, wearing gloves.
4. Follow further cleaning/sanitization procedures for test surfaces as applicable.

B. Place Spacers in Test Sample Tray; Flush with Test Sample tray side furthest from Abrasion Tester and Closest to Operator.

(Please see attached diagram: test tray – top view.pdf)

1. Beginning approximately 2.5 inches to 3 inches from left side of tray, place on 4-in x 4-in spacer. (Spacer 1)
2. Flush with and immediately to right of Spacer 1, place 1-in x 1-in spacer. (Spacer 2)
3. Flush with and immediately to right of Spacer 2, place second 4-in x 4-in spacer. (Spacer 3)
4. Flush with and immediately to right of Spacer 3, place third 4-in x 4-in spacer. (Spacer 4)
5. Clamp Spacers 1, 3, 4 (Hand tight) with "C" clamps. (All 4-in x 4-in spacers.)
6. **Note:** If using Glass microscope slides as test surface, use thick (minimum 1/4 -in) glass for spacers. Place additional whole microscope slides into space between 4-in spacers 1 and 3 until height is one microscope slide thickness lower than the spacers. Place the 1-in x 1-in spacer (Spacer 2) on top of microscope slides. (This allows glass to be clamped without breaking. Make sure that top of spacers and test surfaces are level.)

#### IV. Abrasion Boat Assembly

- A. Please see attached diagram for abrasion boat assembly
- B. Place 2-in strip of Cotton Cloth on clean surface.
- C. Place 2-in strip of Foam Polyurethane wipe directly on top of Cotton Cloth strip.
- D. Place Abrasion Boat Base Plate on Foam wipe, approximately centered.
- E. Fold Foam wipe and cotton wipe around end of Baseplate.
- F. Place one pound weight (WA-2227) on base plate over folded cloth and foam. Weight will hold cloth and foam in place.
- G. Place Abrasion boat cover on base plate over cloth and auxiliary weight.
- H. Place second weight (WA-2210/PO1) on abrasion boat base plate on top of cover.
- I. Press firmly on top of second weight and screw cap tightly.
- J. Weigh Abrasion boat Assembly. Total weight of Abrasion Boat (Baseplate, cover, and cap) with cloth, foam, and two weights =  $1084 \pm 1$  g.
- K. Other weights can be used as long as total weight equals  $1084 \pm 1$  g and motion of Abrasion Tester is not hindered.

#### V. Operation of Abrasion Tester

- A. Place two test surface carriers into 1-in x 2-in space above (closer to Abrasion tester) 1-in x 1-in spacer (Spacer 2.)

B. Place Abrasion Boat Assembly into holes on moving arm of Abrasion tester furthest from the Abrasion Tester (closest to Operator).

(Please see attached diagram)

1. Screws (on ends of Abrasion Boat Cover) are placed in holes on Moving Arm of Abrasion Tester
2. Ensure that Bolts on Abrasion Boat Cover screws are at an appropriate level so that Abrasion boat sits directly on top of test surface spacers.

C. Press Black button on Cycle Index Counter.

1. Moving Arm on Abrasion Tester should move Abrasion Boat over spacers and test surface carriers.
2. Abrasion Boat should NOT be positioned over test carriers during direction change. If Abrasion Boat is positioned over test carriers during direction change, adjust position of all spacers (right or left) to compensate.
3. Two-inch wide abrasion boat should just pass over two-inch space holding test carriers. Adjust position of test carrier space up or down, accordingly (forward/up or backward/down: where "up" is away from operator/toward Abrasion Tester and "down" is toward operator/away from Abrasion Tester.). Add other spacers if needed.



### Abrasion Tester Set-Up without Abrasion Boat

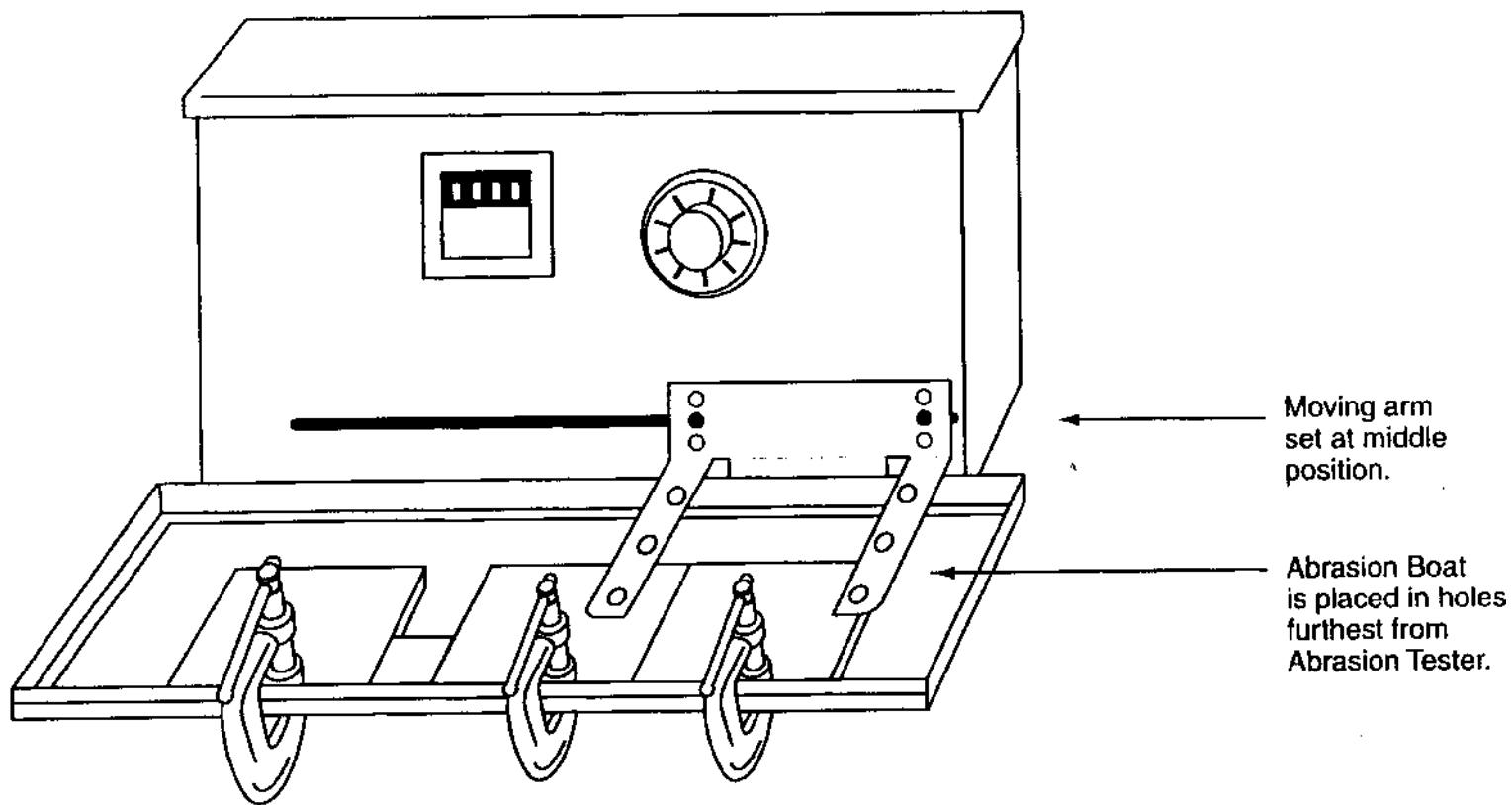

### Test Tray – Top View

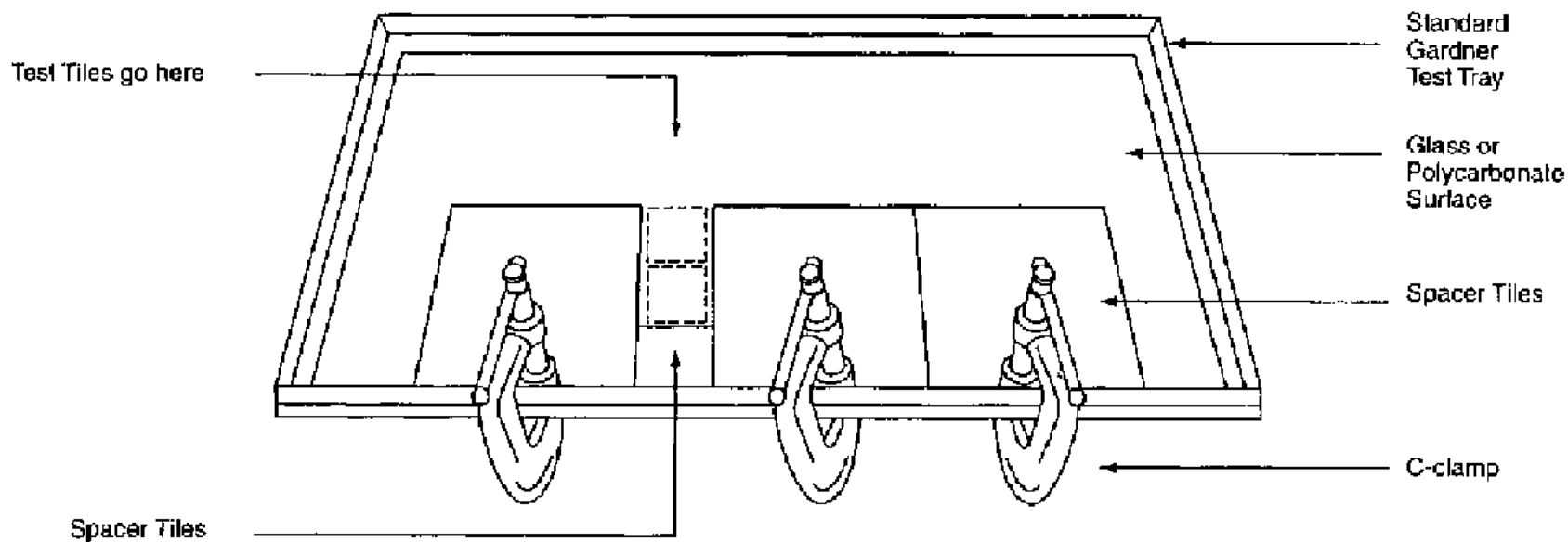

# Abrasion Boat Assembly

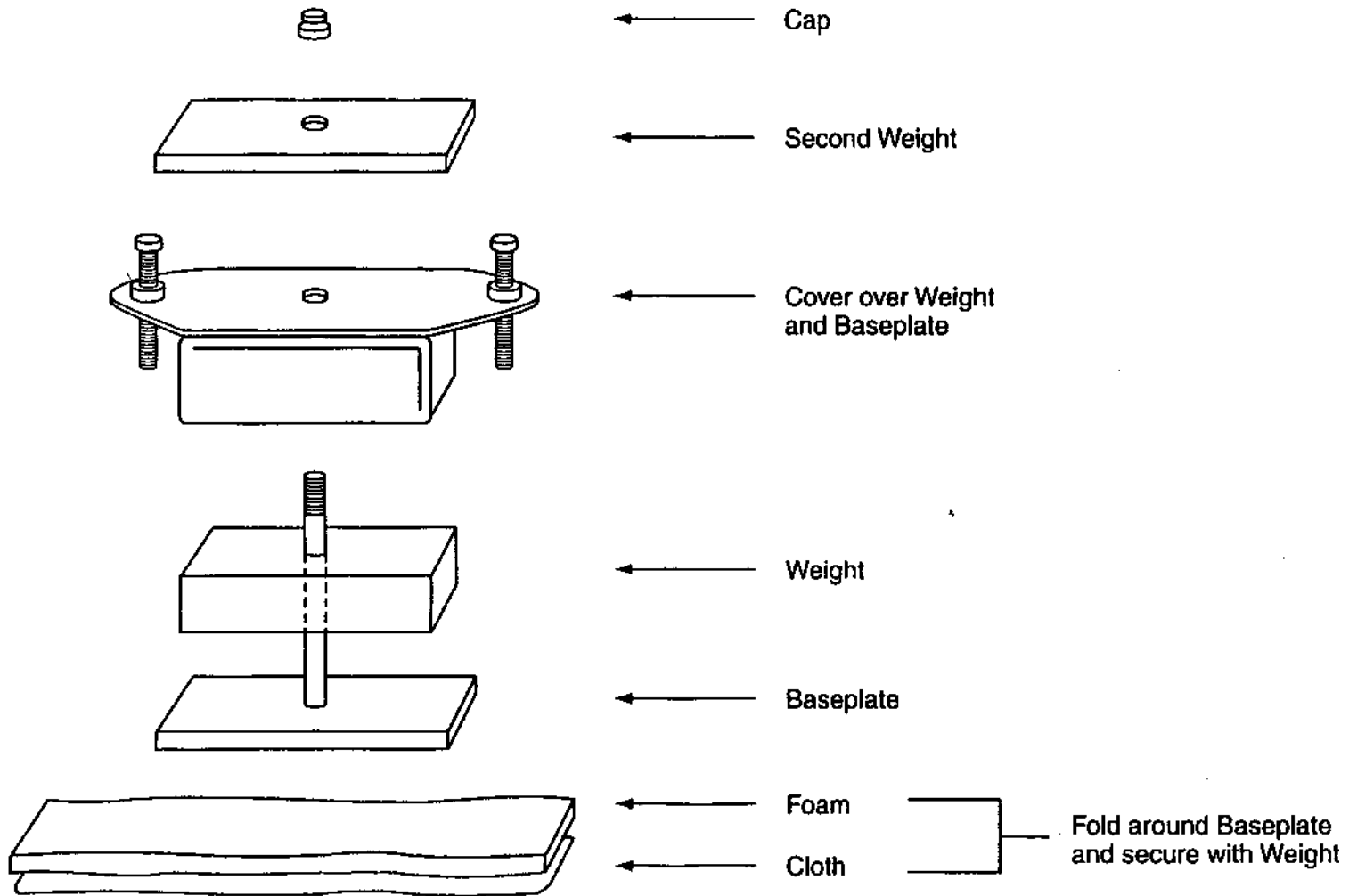

# Abrasion Tester with Abrasion Boat

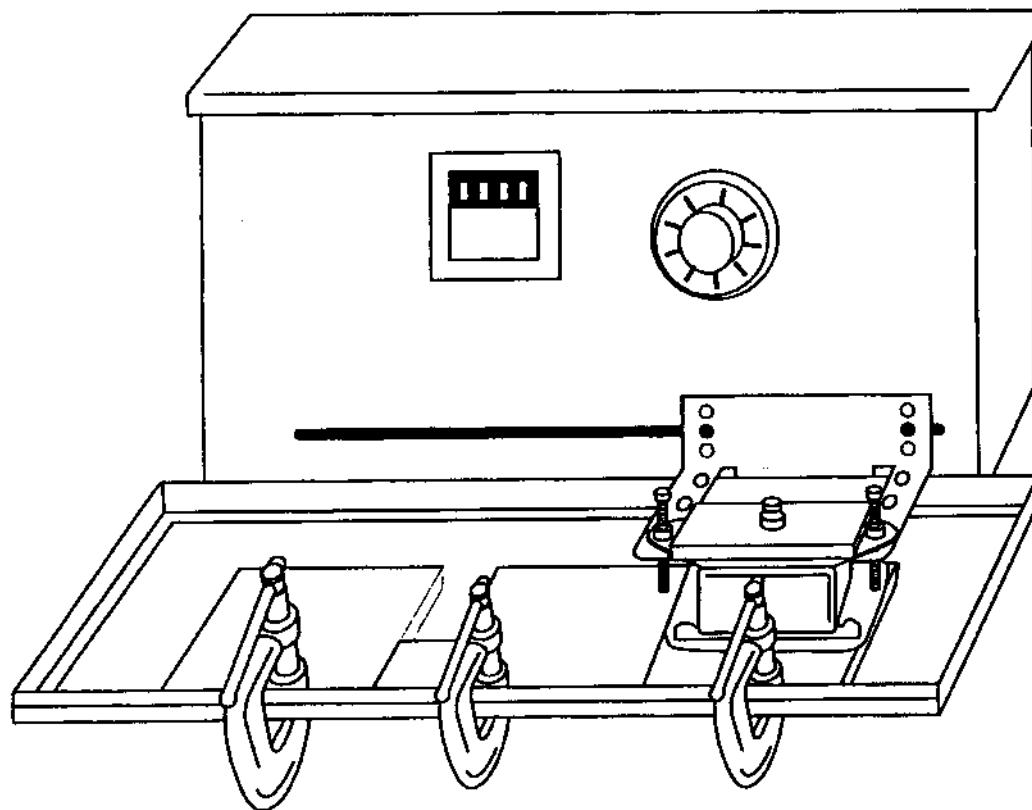

Ensure that abrasion boat rests lightly on surface by adjusting screw, if necessary.  
Abrasion boat should pass directly over space for test surfaces.

## Abrasion Tester – Qualification and Maintenance

## **Title: Abrasion Tester – Qualification and Maintenance**

### **Purpose:**

This SOP define the proper maintenance of the GardCo Washability and Wear Tester (Model D10V, Cat #WA-2153, Paul N. Gardner Co., Inc., Pompano Beach, FL.)

### **Scope:**

The procedures outlined are to be followed by the responsible operator(s) to assure proper operation and maintenance of this equipment. A general operation check should be done periodically (i.e., weekly during the course of GLP testing). Other maintenance should be done yearly.

### **Procedure:**

#### **I. General Operation Check**

##### **A. Cycle Counter**

1. Set up GardCo Abrasion and Washability tester as indicated in Owner/Operation Manual from GardCo
2. Check Cycle Counter.
  - a) Ensure that Abrasion Tester is in “Off” position
  - b) Set Cycle Number.
    - (1) Press black index counter button and hold.
    - (2) Open panel.
    - (3) Set Counter to 1 (1 cycle=2 passes).
    - (4) Close panel.
  - c) Turn “On” Abrasion Tester
  - d) Count Cycles to ensure that number of cycles equals indicated amount.
  - e) Repeat steps a through c for 5, 10 and 20 cycles.
3. If cycles performed does not equal cycles set by counter:
  - a) Repeat steps above to ensure equipment malfunction.

- b) If error in cycle count is determines to be consistent, cycle count can be adjusted to compensate. (Example: Actual cycle count is repeatedly one less than indicated cycle number, set desired cycle count to one more than desired cycle number.)
- c) Contact manufacturer for maintenance/repair.

#### B. Rate Check

1. Set variable speed dial to between 2.25 and 2.5.
2. Check Rate Reproducibility
  - a) Set Cycle Count to 1 (See above)
  - b) Using calibrated Stopwatch, measure time to complete one cycle (two passes).
  - c) Repeat step b two additional times.
  - d) Ensure that cycle rate (time to complete one cycle) is approximately the same (within 0.5 seconds) between the three trials.
3. If cycle rate is not reproducible:
  - a) Repeat steps above to ensure equipment malfunction.
  - b) Contact manufacturer for maintenance/repair.

#### II. Yearly Maintenance

A. Yearly maintenance (specifically oil addition to Abrasion tester chain and associated parts) should be done as recommended by the manufacturer. Please contact GardCo for detailed maintenance instructions. Maintenance procedures should be made only by experienced qualified personnel.

GardCo  
Paul N. Gardner Company, Inc.  
315 N.E. 1<sup>st</sup> Street  
Pompano Beach, FL 33060

1-800-762-2478  
954-946-9454  
Fax: 954-946-9309

#### III. Major Malfunction

A. In case of major malfunction, please contact manufacturer. (See above.)