

US EPA ARCHIVE DOCUMENT

# Environmental Technology Verification Report

Paint Overspray Arrestor  
Purolator Products Air Filtration  
Company  
DMK804404 and PB2424

Prepared by



Research Triangle Institute

Under a Cooperative Agreement with



U.S. Environmental Protection Agency

US EPA ARCHIVE DOCUMENT



# **Environmental Technology Verification Report**

## **Paint Overspray Arrestor**

### **Purolator Products Air Filtration Company DMK804404 and PB2424**

Prepared by

Kathleen Owen  
James Hanley  
Jack Farmer

Air Pollution Control Technology Program  
Research Triangle Institute  
Research Triangle Park, NC 27709-2194

EPA Cooperative Agreement CR 826152-01-2

EPA Project Manager: Theodore G. Brna  
Air Pollution Prevention and Control Division  
National Risk Management Research Laboratory  
Research Triangle Park, NC 27711

March 2000

**Notice**

This document was prepared by the Research Triangle Institute (RTI) under Cooperative Agreement No. CR826152-01-2 with the U.S. Environmental Protection Agency (EPA). The document has been subjected to EPA's peer and administrative reviews and has been approved for publication. Mention of corporation names, trade names, or commercial products does not constitute endorsement or recommendation for use of specific products.

**Availability of Verification Statement and Report**

Copies of the public Verification Statement and Verification Report are available from the following:

1. **Research Triangle Institute**

P.O. Box 12194  
Research Triangle Park, NC 27709-2194

Web site: <http://etv.rti.org/apct/index.html>  
or <http://www.epa.gov/etv> (*click on partners*)

2. **USEPA / APPCD**

MD-4  
Research Triangle Park, NC 27711

Web site: <http://www.epa.gov/etv/library.htm> (*electronic copy*)  
<http://www.epa.gov/ncepihom/>

### **Abstract**

Paint overspray arrestors (POAs) were evaluated by the Air Pollution Control Technology (APCT) pilot of the Environmental Technology Verification (ETV) Program. The performance factor verified was the particle filtration efficiency as a function of size for particles smaller than 10  $\mu\text{m}$ . The APCT ETV Program developed a generic verification protocol for testing filtration efficiency that is based on EPA Method 319. The protocol was developed by RTI, reviewed by a technical panel of experts, and approved by EPA. The protocol addresses several issues that Method 319 does not cover, including periodic testing, acquisition of POAs for testing, and product definition. A Test/Quality Assurance Plan was prepared which addresses the test procedure and quality assurance and quality control requirements for obtaining verification data of sufficient quantity and quality to satisfy the data quality objectives.

RTI performed tests on Purolator's DMK804404 and PB2424 during the period September 8-10, 1999. Filter efficiencies were determined. For ready comparison, the filtration efficiency requirements of the National Emission Standards for Hazardous Air Pollutants (NESHAP) are tabulated with the test results. The results indicate that the DMK804404 and PB2424 met the requirements for existing facilities.

**Table of Contents**

	<u>Page</u>
Verification Statement . . . . .	i
Notice . . . . .	vii
Availability of Verification Statement and Report . . . . .	viii
Abstract . . . . .	ix
List of Figures . . . . .	xi
List of Tables . . . . .	xi
List of Abbreviations and Acronyms . . . . .	xii
Acknowledgments . . . . .	xiii
Section 1. Introduction . . . . .	1
Section 2. Verification Test Description . . . . .	1
2.1. Selection of Paint Overspray Arrestors for Testing . . . . .	3
Section 3. Description of Arrestor . . . . .	3
Section 4. Verification of Performance . . . . .	3
4.1. Quality Assurance . . . . .	3
4.2. Results . . . . .	3
4.3. Limitations and Applications . . . . .	4
Section 5. References . . . . .	4
Appendix A. Description of the Test Rig and Methodology . . . . .	A-1
Appendix B. Certificates of Calibration . . . . .	B-1
Appendix C. Fractional Efficiency Data Sheets . . . . .	C-1

**List of Figures**

	<u>Page</u>
Figure 1. Photograph of the Purolator DMK804404 and PB2424 paint overspray arrestor system . . . .	iii
Figure 2. Triplicate solid-phase particle removal efficiency curves for Purolator DMK804404 and PB2424 paint overspray arrestor system. . . . .	7
Figure 3. Average of the solid-phase particle removal efficiency curves for Purolator DMK804404 and PB2424 paint overspray arrestor system. . . . .	8
Figure 4. Triplicate liquid-phase particle removal efficiency curves for Purolator DMK804404 and PB2424 paint overspray arrestor system . . . . .	9
Figure 5. Average of the liquid-phase particle removal efficiency curves for Purolator DMK804404 and PB2424 paint overspray arrestor system . . . . .	10
Figure A-1. Schematic illustration of the fractional efficiency test rig. . . . .	A-2

**List of Tables**

Table 1. Existing Sources: Liquid-Phase Challenge Aerosol Particles . . . . .	iv
Table 2. Existing Sources: Solid-Phase Challenge Aerosol Particles . . . . .	iv
Table 3. New Sources: Liquid-Phase Challenge Aerosol Particles . . . . .	iv
Table 4. New Sources: Solid-Phase Challenge Aerosol Particles . . . . .	iv
Table 5. Test Series . . . . .	2
Table 6. Summary of Solid-Phase Test Results . . . . .	5
Table 7. Summary of Liquid-Phase Test Results . . . . .	6
Table 8. Summary of Pressure Drop Measurements . . . . .	11
Table A-1. Physical and Aerodynamic Sizing Channels for the Calibration and Test Aerosols . . . . .	A-6



### List of Abbreviations and Acronyms

APCT	Air Pollution Control Technology
APPCD	Air Pollution Prevention and Control Division
ASME	American Society of Mechanical Engineers
cfm	cubic feet per minute
cm	centimeter
Diam.	Diameter
DQO	data quality objective
EPA	U.S. Environmental Protection Agency
ETV	Environmental Technology Verification
fpm	feet per minute
ft <sup>3</sup>	cubic foot
g	gram
Geo.	geometric
HEPA	high efficiency particulate air
ID	inside diameter
in.	inch
kW	kilowatt
L	liter
mL	milliliter
mm	millimeter
m/s	meters per second
NESHAP	National Emission Standards for Hazardous Air Pollutants
OPC	optical particle counter
Pa	pascal
POA	paint overspray arrestor
PSL	polystyrene latex
QA	quality assurance
RTI	Research Triangle Institute
s or sec	second
µm or um	micrometer

### **Acknowledgments**

RTI acknowledges the support of all those who helped plan and conduct the verification activities. In particular, we would like to thank Ted Brna, EPA Project Manager, and Paul Groff, EPA Quality Manager, of EPA's National Risk Management Research Laboratory in Research Triangle Park, NC. Finally we would like to acknowledge the assistance and participation of Tom Justice of Purolator.

For more information on the Paint Overspray Arrestor Verification Testing, contact

James Hanley  
Research Triangle Institute  
P.O. Box 12194  
Research Triangle Park, NC 27709-2194  
(919) 541-5811

For more information on the Purolator DMK804404 and PB2424, contact

Tom Justice  
Purolator Products Air Filtration Company  
880 Facet Rd.  
Henderson, NC 27536  
(252) 492-1141 ext 4201

## **SECTION 1 INTRODUCTION**

The U.S. Environmental Protection Agency (EPA) has created the Environmental Technology Verification (ETV) Program to facilitate the deployment of innovative or improved technologies through performance verification and information dissemination. The ETV Program is intended to assist and inform those involved in the design, distribution, permitting, and purchase of environmental technologies.

The U.S. EPA's partner in the Air Pollution Control Technology (APCT) Program is Research Triangle Institute (RTI). The APCT Program, with the full participation of the technology developer, develops plans, conducts tests, collects and analyzes data, and reports findings. The evaluations are conducted according to a rigorous protocol and quality assurance and quality control oversight. The APCT Program verifies the performance of commercial-ready technologies used to control air pollutant emissions, with an emphasis on technologies for controlling particulate matter, volatile organic compounds, nitrogen oxides, and hazardous air pollutants. The Program develops standardized verification protocols and test plans, conducts independent testing of technologies, and prepares verification test reports and statements for broad dissemination.

## **SECTION 2 VERIFICATION TEST DESCRIPTION**

The paint overspray arrestor was tested in accordance with the APCT "Generic Verification Protocol for Paint Overspray Arrestors"<sup>1</sup> and the "Test/QA Plan for Paint Overspray Arrestors."<sup>2</sup> This protocol incorporates all requirements of EPA Method 319: Determination of Filtration Efficiency for Paint Overspray Arrestors. Method 319<sup>3</sup> is part of the National Emission Standards for Hazardous Air Pollutants (NESHAP) for Aerospace Manufacturing and Rework Facilities.<sup>4</sup> The protocol also includes requirements for quality management, quality assurance, procedures for product selection, auditing of the test laboratories, and reporting format.

Filtration efficiency was computed from aerosol concentrations measured upstream and downstream of an arrestor installed in a laboratory test rig. The aerosol concentrations upstream and downstream of the arrestors were measured with an aerosol analyzer that simultaneously counts and sizes the particles in the aerosol stream. The aerosol analyzer covered the particle diameter size range from 0.3 to 10  $\mu\text{m}$  in a series of contiguous sizing channels. Each sizing channel covered a narrow range of particle diameters. For example, channel 1 covered from 0.3 to 0.4  $\mu\text{m}$ , channel 2 from 0.4 to 0.5  $\mu\text{m}$ , and channel 15 from 7 to 10  $\mu\text{m}$ . By taking the ratio of the downstream to upstream particle counts on a channel by channel basis, the filtration efficiency was computed for each of the sizing channels.

The upstream and downstream aerosol measurements were made while a test aerosol was injected into the air stream upstream of the arrestor [ambient aerosol is first removed from the upstream air with high efficiency particulate air (HEPA) filters on the inlet of the test rig]. This test aerosol spanned the particle

Purolator DMK804404 and PB2424

size range from 0.3 to 10 µm and provided a sufficient upstream concentration in each of the sizing channels to allow calculation of filtration efficiencies up to 99%.

The following series of tests were performed at a face velocity of 120 fpm (0.61 m/s):

- C Three arrestors were tested using a liquid-phase aerosol challenge,
- C Three arrestors were tested using a solid-phase aerosol challenge,
- C Seven “no-filter” control tests (one performed prior to each arrestor and reference filter test),
- C One HEPA filter control test, and
- C One reference filter control test.

The test series is exhibited in Table 5. Additional details on the test procedure are provided in Appendix A.

**TABLE 5. TEST SERIES**

RTI Test No.	TYPE OF TEST				Challenge Aerosol
	No-Filter	Test Arrestor	HEPA Filter	Reference Filter	
09099908	X				Solid-Phase
09099909				X	
09099906	X				
09099907		X			
09099910	X				
09099911		X			
09109901	X				
09109902		X			
08319904			X		
09089908	X				Liquid-Phase
09089909		X			
09099902	X				
09099903		X			
09099904	X				
09099905		X			

## 2.1 SELECTION OF PAINT OVERSPRAY ARRESTORS FOR TESTING

The test arrestors (DMK804404 and PB2424) were supplied to RTI with a letter from Mr. Tom Justice, VP of operations, as being representative of typical production. The PB2424 were sent from stock. The DMK804404 were ordered and shipped with no unusual quality control procedures.

## SECTION 3 DESCRIPTION OF ARRESTOR

As shown in Figure 1 (page iii), the Purolator DMK804404 and PB2424 is a two stage system consisting of the DMK804404 pleated panel filter and the PB2424 flat panel filter. The DMK804404, also known as Mark 80D, has nominal dimensions of 24 x 24 x 4 in. (0.61 x 0.61 x 0.10 m), 20 pleats, and blue media in a white cardboard frame. The DMK804404 is labeled directly on the cardboard stating: Mark80D Medium Efficiency Panel Air Filter, Purolator Products Air Filtration Company, 24" x 24" Nominal Size, 23 3/8" x 23 3/8" x 3 3/4" (59.3 cm x 59.3 cm x 9.5 cm) exact size. The DMK804404 has an arrow indicating flow direction.

The PB2424, also know as Prebond, is nominally 25 x 25 x 2 in. (0.64 x 0.64 x 0.05 m), has tackified white media with a coarser upstream layer and thicker downstream layer, and is not individually labeled. The box containing the PB2424 was labeled: FACET-AIRE Air Filters, 12 ea., 25x25x2.

## SECTION 4 VERIFICATION OF PERFORMANCE

### 4.1 QUALITY ASSURANCE

The verification tests were conducted in accordance with an approved Test/Quality Assurance (QA) Plan.<sup>2</sup> The EPA Quality Manager conducted an independent assessment of the test laboratory in August 1999 and found that the test laboratory was being operated as specified in the Test/QA Plan. Additionally, APCT Quality Assurance staff have reviewed the results of this test and have found that the results meet data quality objectives in the Test/QA Plan. Certificates of Calibration for the optical particle counter and the airflow reference devices are provided in Appendix B.

### 4.2 RESULTS

Tables 6 and 7 and Figures 2 through 5 summarize the fractional filtration efficiency measurements for the solid- and liquid-phase tests. Upstream and downstream particle count data for each test are provided in Appendix C.

The initial (new condition) pressure drop across each test arrestor at the 120 fpm (0.61 m/s) test velocity [for a flowrate of 480 cfm (0.23 m<sup>3</sup>/s)] is shown in Table 8. The pressure drop across the tested arrestors ranged from 0.10 to 0.11 in. H<sub>2</sub>O (25 to 27 Pa) for each of the six arrestors tested.

Tables 1-4 (page iv) present the filtration efficiency requirements of the Aerospace NESHAP and the corresponding efficiencies measured for the tested arrestor system. The test results indicate that the tested arrestor met the NESHAP requirements for existing sources but not those for new sources.

### 4.3 LIMITATIONS AND APPLICATIONS

This verification report addresses two aspects of paint overspray arrestor performance: filtration efficiency and pressure drop. Users of this technology may wish to consider other performance parameters such as service life and cost when selecting a paint overspray arrestor for their use.

In accordance with the generic verification protocol, this Verification Statement is applicable to paint overspray arrestors manufactured between the publication date of the Verification Statement and 12 months thereafter.

As stated in Section 1.3 of Method 319<sup>3</sup>, "for a paint arrestor system or subsystem which has been tested by this method, adding additional filtration devices to the system or subsystem shall be assumed to result in an efficiency of at least that of the original system without additional testing."

### SECTION 5 REFERENCES

1. Generic Verification Protocol for Paint Overspray Arrestors, Research Triangle Institute, Research Triangle Park, NC, August 1999.
2. Test/QA Plan for Paint Overspray Arrestors, Research Triangle Institute, Research Triangle Park, NC, February 1999.
3. Method 319: Determination of Filtration Efficiency for Paint Overspray Arrestors. *Code of Federal Regulations*, Appendix A to 40 CFR Part 63.
4. National Emission Standards for Hazardous Air Pollutants for Aerospace Manufacturing and Rework Facilities. *Code of Federal Regulations*, Title 40, Part 63, Subpart GG (40 CFR 63.741).

**TABLE 6. SUMMARY OF SOLID-PHASE TEST RESULTS**

Filtration Efficiency (%) at Indicated Size Range																
OPC Channel Number	1	2	3	4	5	6	7	8	9	10	11	12	13	14	15	
Min. Diam. (um)	0.45	0.59	0.73	0.80	1.02	1.44	1.86	2.28	2.85	3.13	4.25	5.66	7.07	7.77	9.88	
Max. Diam. (um)	0.59	0.73	0.80	1.02	1.44	1.86	2.28	2.85	3.13	4.25	5.66	7.07	7.77	9.88	14.10	
Geo. Mean Diam (um)	0.52	0.66	0.77	0.90	1.21	1.64	2.06	2.55	2.98	3.65	4.91	6.33	7.41	8.76	11.81	
Purolator 2-Stage System (DMK804404 with PB2424)																
Run #1	09099907	38	41	44	48	54	61	68	76	83	89	95	98	99	100	
Run #2	09099911	38	41	46	49	55	62	68	78	85	90	96	99	99	100	
Run #3	09109902	37	41	45	48	54	61	67	76	84	89	95	98	98	99	
Average		37	41	45	48	54	61	68	77	84	89	96	98	99	100	
Interpolated Efficiency Values (%) for Existing Source Criteria:																
2.60 um (> 10% required):	77															
5.00 um (> 50% required):	96															
8.10 um (> 90% required):	99															
Interpolated Efficiency Values (%) for New Source Criteria:																
0.70 um (> 75% required):	43															
1.10 um (> 85% required):	52															
2.50 um (> 95% required):	76															
HEPA Filter Control Test (applicable to both solid and liquid phase conditions)																
Run #1	08319904	100	100	100	100	100	100	100	100	100	100	100	100	100	100	
Reference Filter QA Test																
Current	09099909	1	3	3	3	4	6	5	9	13	21	42	66	79	86	90
Baseline	08279902	1	1	0	1	1	4	4	7	14	19	42	68	81	86	92
Difference		0	2	3	2	3	2	1	2	0	2	1	-1	-2	0	-2
Acceptable (<10)		yes	yes	yes	yes	yes	yes	yes	yes	yes	yes	yes	yes	yes	yes	yes
"No Filter" Control Tests																
Penetration For Each Size Range																
Run #1	09099906	0.99	1.00	0.99	1.00	1.01	1.00	1.00	0.98	0.99	0.99	1.00	0.95	0.90	0.92	0.93
Run #2	09099910	1.00	0.98	0.98	1.00	1.00	0.99	0.99	0.99	0.98	1.00	1.01	0.97	0.93	1.00	0.99
Run #3	09109901	1.01	1.01	1.02	1.02	1.02	1.01	1.02	1.00	1.01	0.99	0.99	0.99	0.99	0.92	0.91

**TABLE 7. SUMMARY OF LIQUID- PHASE TEST RESULTS**

Filtration Efficiency (%) at Indicated Size Range																
OPC Channel Number	1	2	3	4	5	6	7	8	9	10	11	12	13	14	15	
Min. Diam. (um)	0.28	0.37	0.47	0.52	0.66	0.94	1.22	1.51	1.88	2.07	2.83	3.77	4.71	5.18	6.60	
Max. Diam. (um)	0.37	0.47	0.52	0.66	0.94	1.22	1.51	1.88	2.07	2.83	3.77	4.71	5.18	6.60	9.43	
Geo. Mean Diam (um)	0.32	0.418	0.49	0.58	0.78	1.07	1.36	1.68	1.97	2.42	3.26	4.21	4.94	5.85	7.89	
Purolator 2-Stage System (DMK804404 with PB2424)																
Run #1	09089909	30	31	33	32	36	41	48	60	70	77	90	97	99	100	100
Run #2	09099903	27	29	30	30	33	38	44	55	66	74	88	97	98	99	100
Run #3	09099905	27	29	30	29	34	39	45	54	65	73	88	96	98	99	100
Average		28	30	31	30	34	39	46	56	67	75	89	97	98	99	100
Interpolated Efficiency Values (%) for Existing Source Criteria:																
2.20 um (> 10% required):	71															
4.10 um (> 50% required):	96															
5.70 um (> 90% required):	99															
Interpolated Efficiency Values (%) for New Source Criteria:																
0.42 um (> 65% required):	30															
1.00 um (> 80% required):	38															
2.00 um (> 95% required):	68															
"No Filter" Control Tests																
Penetration For Each Size Range																
Run #1	09089908	1.00	1.00	1.01	1.00	1.00	0.99	0.99	1.00	0.99	0.99	0.99	0.94	0.88	0.80	0.66
Run #2	09099902	1.01	1.01	1.01	1.01	1.01	1.01	1.01	1.01	1.03	1.00	1.00	1.00	1.03	0.99	0.98
Run #3	09099904	1.01	1.01	1.02	1.00	1.01	1.02	1.02	1.00	1.00	1.01	1.00	0.96	0.97	0.94	0.97

US EPA ARCHIVE DOCUMENT



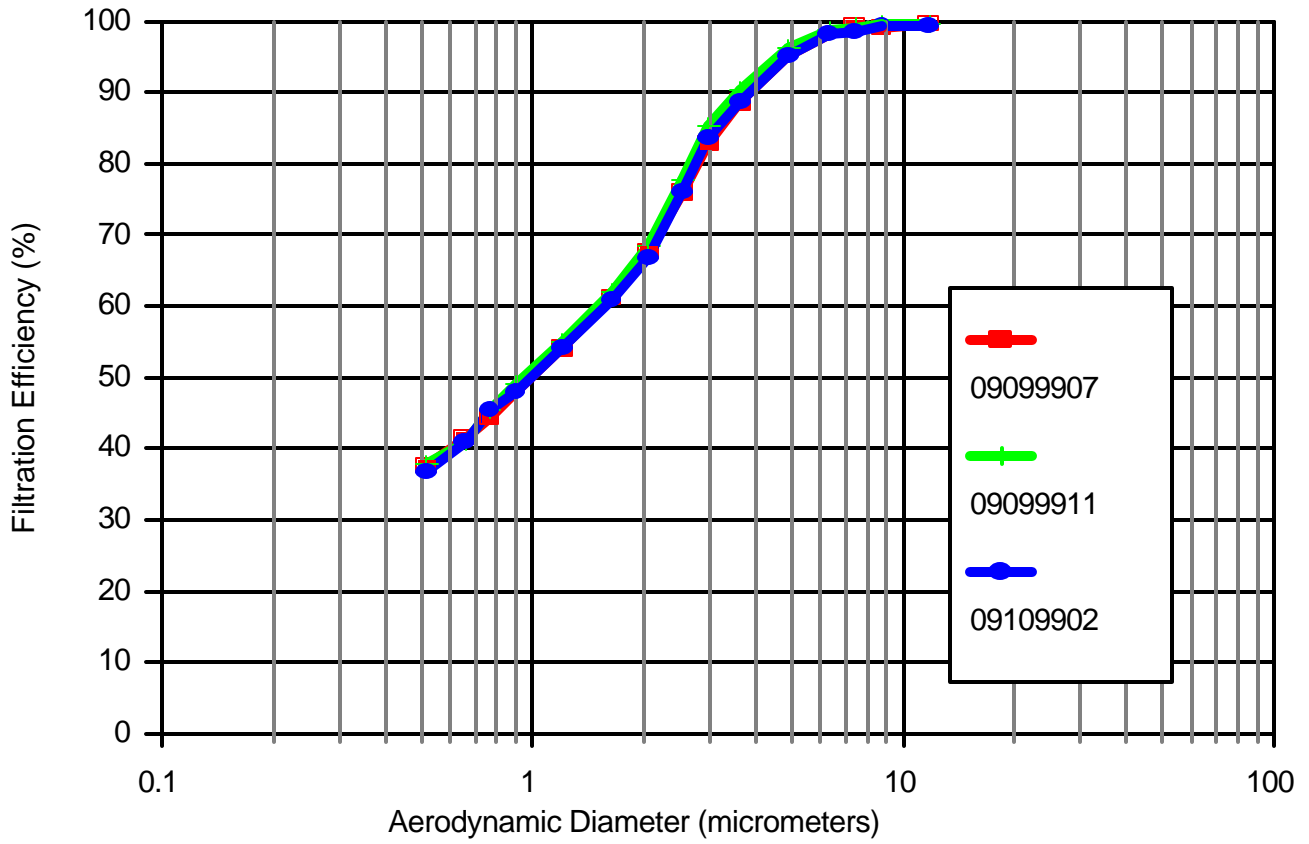

Figure 2. Triplicate solid-phase particle removal efficiency curves for the Purolator DMK804404 and PB2424 paint overspray arrestor system.

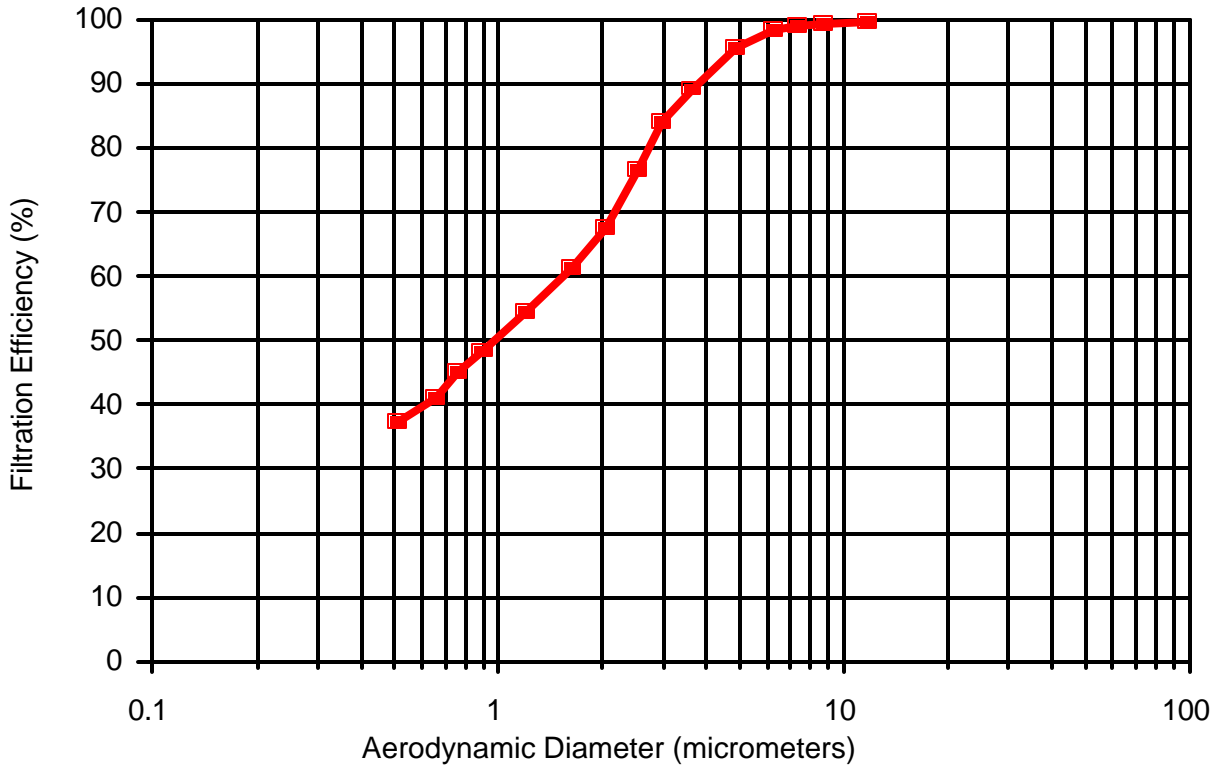

Figure 3. Average of the solid-phase particle removal efficiency curves for the Purolator DMK804404 and PB2424 paint overspray arrestor system.

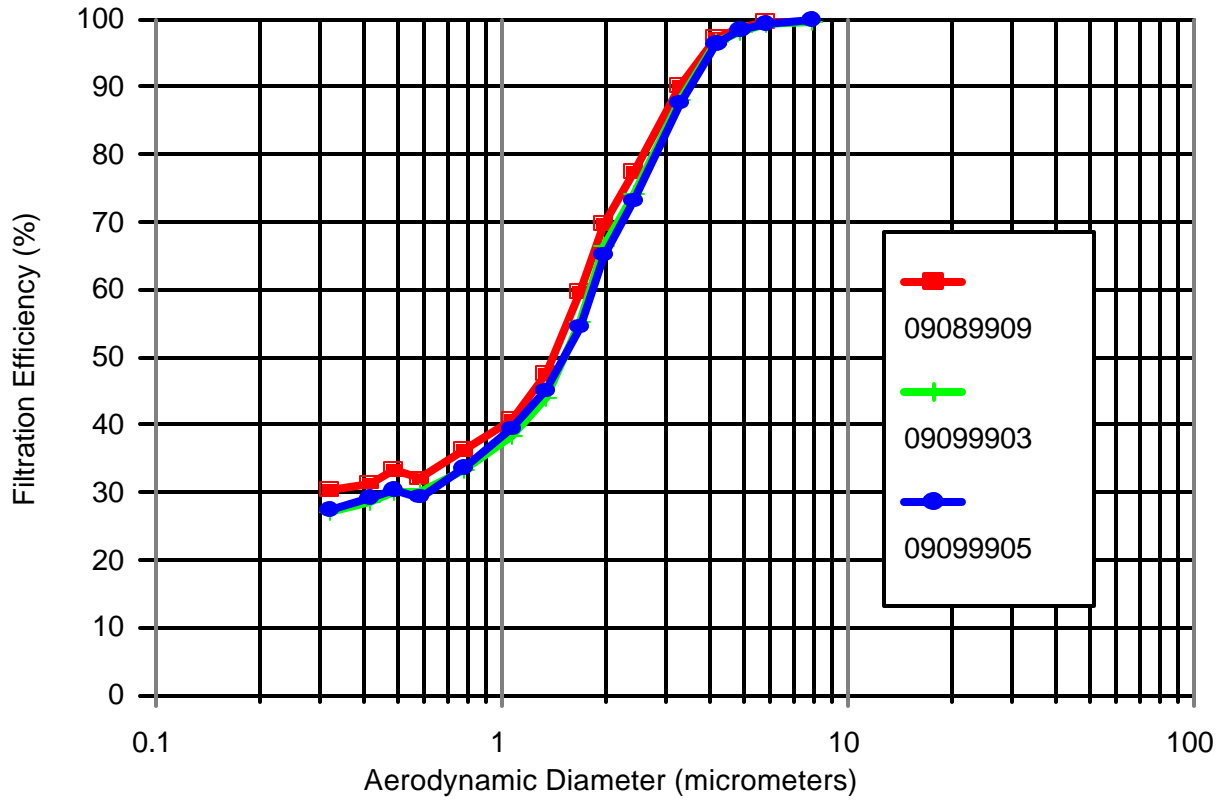

Figure 4. Triplicate liquid-phase particle removal efficiency curves for the Purolator DMK804404 and PB2424 paint overspray arrestor system.

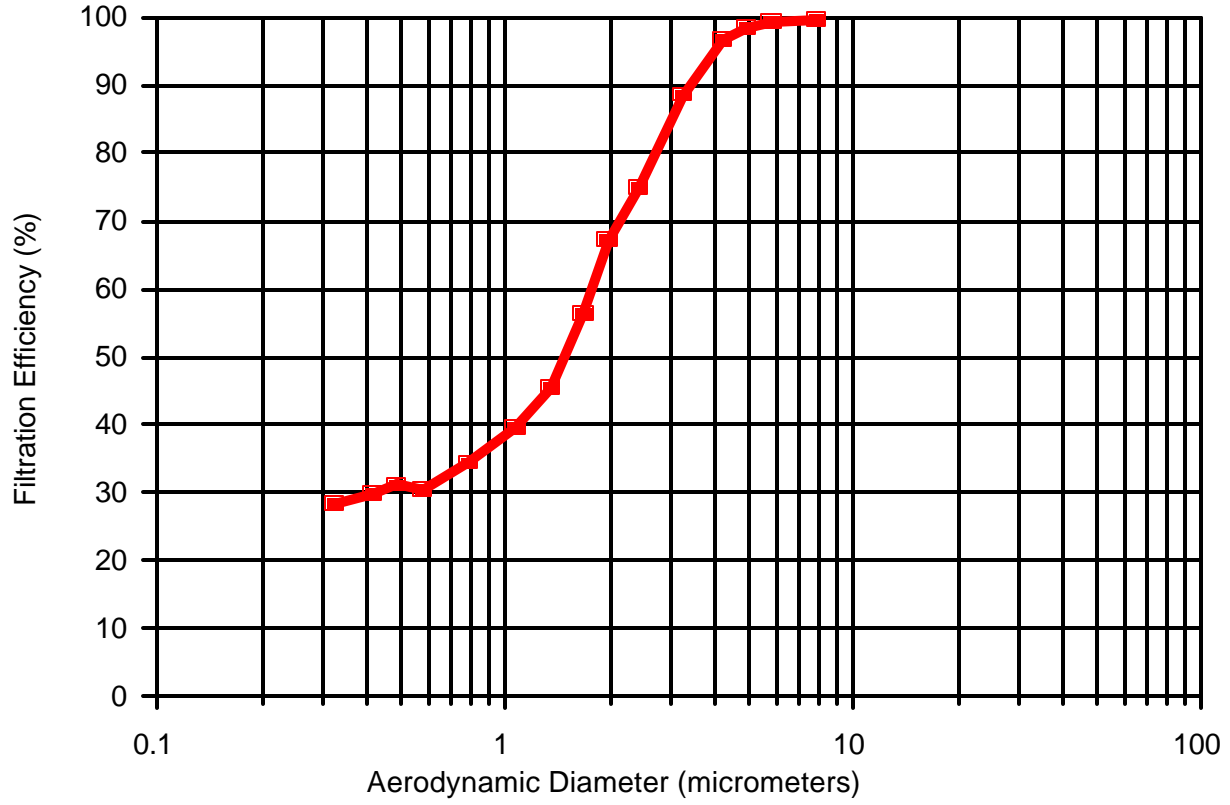

Figure 5. Average of the liquid-phase particle removal efficiency curves for the Purolator DMK804404 and PB2424 paint overspray arrestor system.

**TABLE 8.**  
**SUMMARY OF PRESSURE DROP MEASUREMENTS**

Test No.	Initial Pressure Drop (inch H <sub>2</sub> O)	Initial Pressure Drop (Pa)
09099907	0.10	25
09099911	0.10	25
09109902	0.10	25
09089909	0.11	27
09099903	0.10	25
09099905	0.10	25

## Appendix A

### DESCRIPTION OF THE TEST RIG AND METHODOLOGY

#### TEST DUCT

The tests were conducted in RTI's air cleaner test facility (Figure A-1). The test rig's ducting was primarily of 24 x 24 in. (0.61 x 0.61m) cross section and made of 14-gauge stainless steel. The blower is rated at 15 hp (11 kW) with a flow capacity of 3000 cfm (1.4 m<sup>3</sup>/s) at 13 in. H<sub>2</sub>O (3200 Pa). The inlet and outlet filter banks consist of two 24 x 24 x 2 in. (0.61 x 0.61 x 0.05 m) prefilters and two 24 x 24 x 12 in. (0.61 x 0.61 x 0.30 m) high efficiency particulate air (HEPA) filters rated at 2000 cfm (0.9 m<sup>3</sup>/s) each. The system operates at positive pressure to minimize infiltration of room air.

To mix the test aerosol with the air stream, an orifice plate and mixing baffle were located immediately downstream of the aerosol injection point and upstream of the test arrestor. An identical orifice plate and mixing baffle were added after the 180° bend. The latter downstream orifice served two purposes. It straightened out the flow after going around the bend, and it mixed any aerosol that penetrated the air cleaning device. Mixing the penetrating aerosol with the air stream is necessary to obtain a representative downstream aerosol measurement.

#### AIRFLOW

Airflow was measured with a 4.00 in. (0.102 m) ID American Society of Mechanical Engineers (ASME) flow nozzle. The nominal velocity through the arrestor was computed by dividing the volumetric flow by the nominal face area of the device. Airflow was manually controlled by a 14 in. (0.36 m) diameter butterfly valve.

#### OPTICAL PARTICLE COUNTER (OPC)

Aerosol concentrations were measured with a Climet Instruments Model 226 OPC. This OPC uses a white-light illumination source and has a wide collection angle for the scattered light. The OPC's sampling rate was 0.25 cfm (0.00012 m<sup>3</sup>/s).

The output of the OPC was input to a Climet Instruments Model 8040 multichannel analyzer equipped with Model 05872005 and 05872006 input boards. These boards provide 16 sizing channels covering the range from 0.3 to 10 μm. The 8040 was also equipped with a Model CI-298 sequential interface board. This interface provides a contact closure at the end of each sample and also provides a 15-sec delay in particle counting after each sample. The contact closure was used to control the operation of electromechanical valve actuators in the upstream and downstream sample lines. The 15-sec delay allows time for the new sample to be acquired.

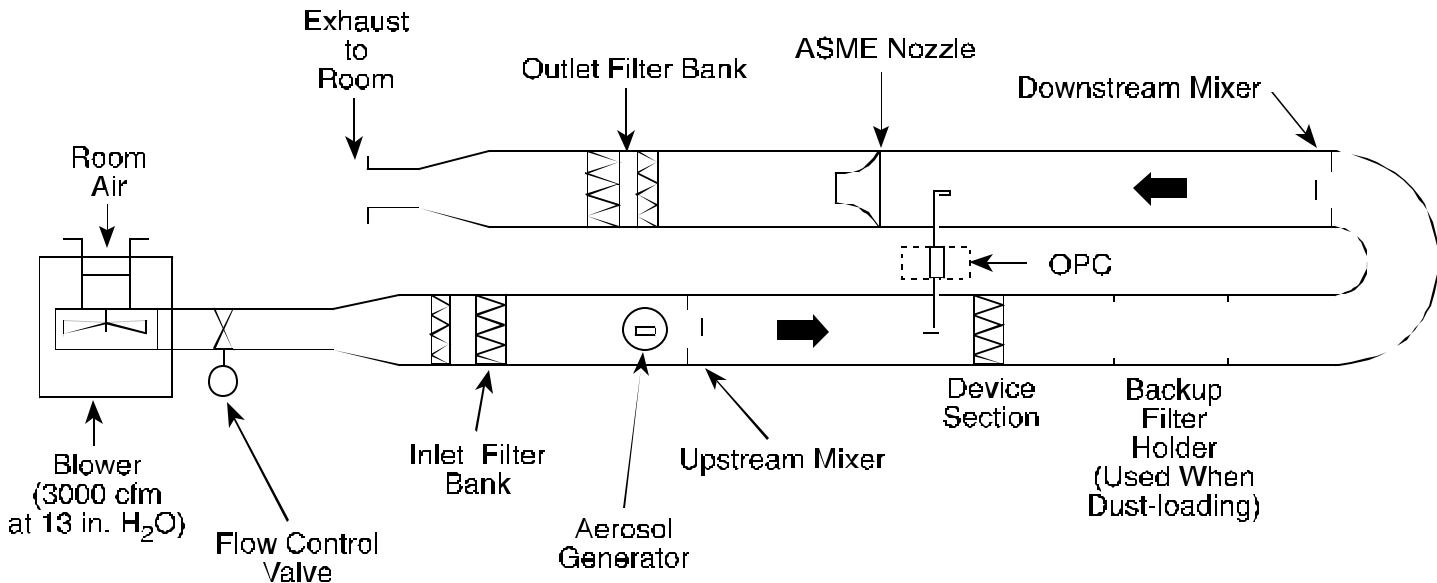

Overview of Test Duct Configuration (Top View)

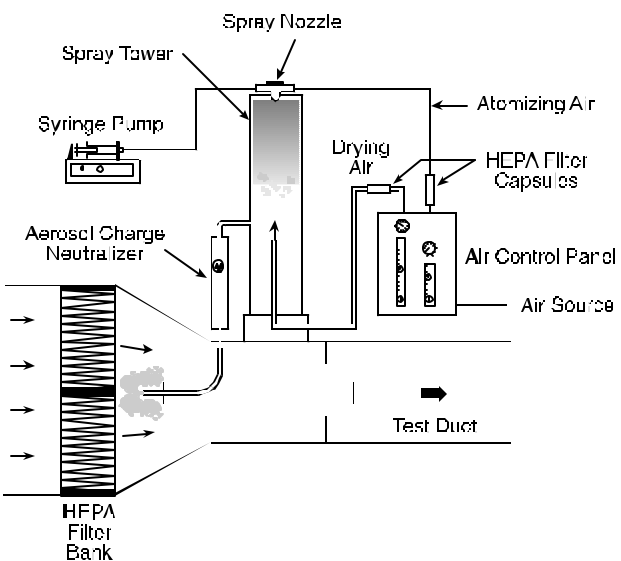

Aerosol Generation System (Side View)

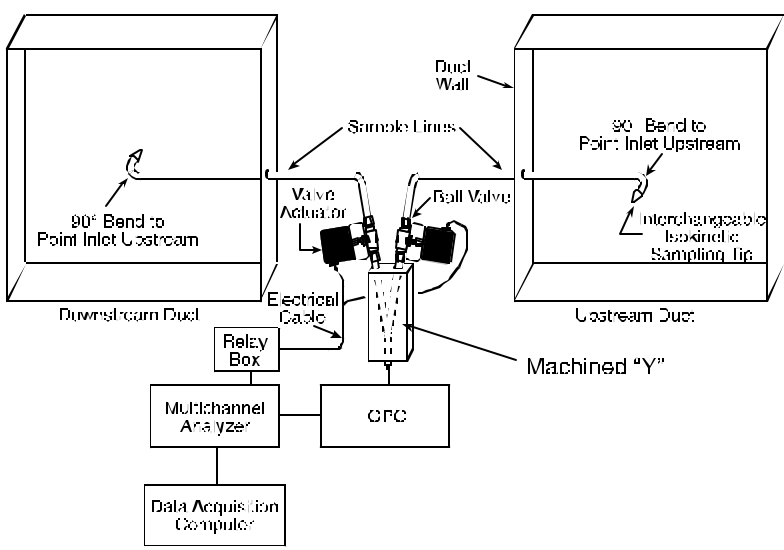

Aerosol Sampling System (End View)

Figure A-1. Schematic illustration of the fractional efficiency test rig.

## AEROSOL GENERATION

Two types of challenge aerosols were used: liquid- and solid-phase. The selection of liquid- or solid-phase challenge aerosol particles is important because for some types of paint arrestors significantly different filtration efficiencies will be achieved depending upon the phase of the challenge aerosol particles. (This is due to particle "bounce" associated with solid-phase particles.) The liquid-phase challenge aerosol is oleic acid, a non-toxic, low-volatility liquid. The solid-phase aerosol is potassium chloride (KCl) generated from an aqueous solution. KCl was selected as the solid-phase aerosol because of its relatively high water solubility, high deliquescence humidity (85% relative humidity), known crystalline structure (facilitates complete drying), and low toxicity. The KCl solution was prepared by combining 0.66 lb (300 g) of KCl with 0.035 ft<sup>3</sup> (1 L) of distilled water. Both oleic acid and KCl are compatible with accurate measurement by the optical particle counter.

The oleic acid or the KCl solution was nebulized using a two-fluid (air and liquid) air atomizing nozzle (Spray Systems 1/4 J siphon spray nozzle) as illustrated in Figure A-1 (aerosol generation system). The nozzle was positioned at the top of a 12 in. (0.30 m) diameter, 51 in. (1.3 m) tall transparent acrylic spray tower. The tower served two purposes. It allowed the salt droplets to dry by providing an approximate 40 sec mean residence time, and it allowed larger-sized particles (of either KCl or oleic acid) to fall out of the aerosol. After generation, the aerosol passed through a TSI Model 3054 aerosol neutralizer (Kr-85 radioactive source) to neutralize any electrostatic charge on the aerosol (electrostatic charging is an unavoidable consequence of most aerosol-generation methods).

The KCl solution or oleic acid was fed to the atomizing nozzle at 1.2 mL/min by means of a pump. Varying the operating air pressure of the generator allows control of the output aerosol concentration.

## AEROSOL SAMPLING SYSTEM

The aerosol sampling lines were 0.55 in. (14 mm) ID stainless steel lines and used gradual bends [radius of curvature = 2.25 in. (57 mm)] when needed. These dimensions were chosen to minimize particle losses in the sample lines. A custom-made "Y" fitting connected the upstream and downstream lines to the OPC. The two branches of the "Y" merged gradually to minimize particle loss in the intersection of the "Y" due to centrifugal or impaction forces.

Immediately above the "Y," electrically actuated ball valves were installed in each branch (Parker Model EA Electro-Mechanical Valve Actuator). The opening and closing of the valves were automatically controlled by the OPC's sequential sampling interface board. The valves take approximately 2 sec to complete an opening or closing maneuver.

Isokinetic sampling nozzles of the appropriate entrance diameter were placed on the ends of the sample probes to maintain isokinetic sampling for all the test flow rates.



## TEST PROCEDURES

The aerosol penetration of the test device was calculated from the average of 10 upstream and 10 downstream samples taken sequentially (i.e., one upstream, one downstream, one upstream, one downstream, . . . until 10 each were obtained). This sequential sampling scheme was selected to minimize the effect of aerosol generator variability. Each sample was 2 minutes in duration. The sampling also included background upstream and downstream measurements at the beginning and end of each test. The test sequence was as follows:

1. Warm up OPC and install proper sample tips for isokinetic sampling.
2. Install air cleaner test device and bring test duct to desired flow rate.
3. With the aerosol generator off, obtain one measurement each of the upstream and of the downstream background particle counts.
4. Turn on the aerosol generator and allow it to run for a minimum of 10 minutes to stabilize.
5. After the stabilization period, obtain 10 upstream and 10 downstream particle counts using a repeated upstream-downstream sampling sequence until 10 each are obtained.
6. Turn off the aerosol generator. Wait 10 minutes, then obtain one additional upstream and downstream background measurement.

## CONTROL TESTS

In addition to evaluating the test arrestor, 0 and 100% penetration control tests and a reference filter control test were conducted to ensure that reliable measurements are obtained. The 100% penetration test was a relatively stringent test of the adequacy of the overall duct, sampling, measurement, and aerosol generation system. These tests were performed as normal penetration tests except that the paint arrestor was not used. A perfect system would yield a measured penetration of 1 at all particle sizes. Deviations from 1 can occur due to particle losses in the duct, differences in the degree of aerosol uniformity (i.e., mixing) at the upstream and downstream probes, and differences in particle-transport efficiency in the upstream and downstream sampling lines. Results from the 100% penetration tests were used during data analysis to correct penetration measurements obtained during the arrestor tests.

The 0% penetration test was performed by using a HEPA filter rather than a paint arrestor. This test confirmed the adequacy of the instrument response time and sample line lag. The 0% penetration test was performed on a monthly basis.

The reference filter control test consisted of performing a solid-phase efficiency test on the same filter during each ETV test. The reference filter data from each test were compared to the original, baseline reference filter data to determine if there was any substantial change in the test system between the tests.

## DATA ANALYSIS

### *Nomenclature*

- P = Penetration corrected for  $P_{100}$  value
- D = Downstream particle count
- $D_b$  = Downstream background count
- U = Upstream particle count
- $U_b$  = Upstream background count
- $P_{100}$  = 100% penetration value determined from the control tests
- Overbar: denotes arithmetic mean of quantity

Analysis of each test involves the following quantities:

- !  $P_{100}$  value for each sizing channel from the blank (no-filter) test,
- ! 2 upstream background values,
- ! 2 downstream background values,
- ! 10 upstream values with aerosol generator on, and
- ! 10 downstream values with aerosol generator on.

Using the values associated with each sizing channel, the penetration associated with each particle sizing channel was calculated as:

$$P = \{(\bar{D} - \bar{D}_b) / (\bar{U} - \bar{U}_b)\} / P_{100} .$$

Filtration efficiency was then calculated as:

$$\text{Filtration Efficiency (\%)} = 100 (1 - P).$$

### DEFINITION OF PARTICLE DIAMETER

Over the 0.3 to 10  $\mu\text{m}$  diameter size range, the "aerodynamic" particle diameter is often of more significance than the physical diameter (as measured by the OPC) relative to aerosol filtration and aerosol deposition within the human respiratory tract. The aerodynamic diameter ( $D_{\text{Aero}}$ ) is related to the physical diameter ( $D_{\text{Physical}}$ ) by:

$$D_{\text{Aero}} = D_{\text{Physical}} \sqrt{\frac{\rho_{\text{Particle}}}{\rho_o} \frac{CCF_{\text{Physical}}}{CCF_{\text{Aero}}} \frac{1}{X}}$$

where

$\rho_{\text{Particle}}$  is the density of the particle in  $\text{g/cm}^3$ .

$\rho_o$  is unit density of 1  $\text{g/cm}^3$ .

$CCF_{\text{Physical}}$  is the Cunningham Correction Factor at  $D_{\text{Physical}}$ .

$CCF_{\text{Aero}}$  is the Cunningham Correction Factor at  $D_{\text{Aero}}$ .

$X$  is the dynamic shape factor.

Note: due to the interdependence of  $D_{\text{aero}}$  and  $CCF_{\text{Aero}}$ , the equation is solved iteratively.

For oleic acid droplets having a density of 0.89  $\text{g/cm}^3$  and being spherical ( $X = 1$ ), the aerodynamic diameter will be about 6% smaller than the measured diameter.

KCl has a density of 1.98  $\text{g/cm}^3$ . The KCl particles form from the evaporation of aqueous solution droplets. Because KCl has an inherent cubic crystalline structure, it is expected that the KCl particles will be cubic or relatively compact cubic clusters; however, their actual shape, or range of shapes, is unknown. Because the shape factor is unknown, the shape factor for KCl is assigned a value of 1 and the diameter is termed the "nominal" aerodynamic diameter.

The aerodynamic diameters associated with the 15 OPC sizing channels are tabulated in Table A-1 for oleic acid and KCl. Also listed is the physical diameter size range for each channel based on the manufacturer's calibration curve using monodisperse polystyrene latex (PSL) spheres.

**Table A-1. Physical and Aerodynamic Sizing Channels  
for the Calibration and Test Aerosols**

	Particle Diameter Size Range ( $\mu\text{m}$ )*		
	PSL	OLEIC ACID	KCl
OPC Channel Number	Physical Diameter	Aerodynamic Diameter	Nominal Aerodynamic Diameter
1	0.3 - 0.4	0.28 - 0.37	0.45 - 0.59
2	0.4 - 0.5	0.37 - 0.47	0.59 - 0.73
3	0.5 - 0.55	0.47 - 0.52	0.73 - 0.80
4	0.55 - 0.7	0.52 - 0.66	0.80 - 1.02
5	0.7 - 1.0	0.66 - 0.94	1.02 - 1.44
6	1.0 - 1.3	0.94 - 1.22	1.44 - 1.86
7	1.3 - 1.6	1.22 - 1.51	1.86 - 2.28
8	1.6 - 2	1.51 - 1.88	2.28 - 2.85
9	2 - 2.2	1.88 - 2.07	2.85 - 3.13
10	2.2 - 3	2.07 - 2.83	3.13 - 4.25
11	3 - 4	2.83 - 3.77	4.25 - 5.66
12	4 - 5	3.77 - 4.71	5.66 - 7.07
13	5 - 5.5	4.71 - 5.18	7.07 - 7.77
14	5.5 - 7	5.18 - 6.60	7.77 - 9.88
15	7 - 10	6.60 - 9.43	9.88 - 14.1

\*The particle diameter size ranges are defined as greater than the indicated lower limit and less than or equal to the indicated upper limit.

---

**APPENDIX B**  
**Certificates of Calibration**

# Certificate of Traceability

**8500D-II THERMOANEMOMETER**

Model No. 8500D-II      Serial No. 3810      Part No. 634493200

Certificate Number: 1946      Date: 26-Oct-88      P.O. 00329      Order/RMA: 404638  
 Customer Number:

*Calibration Standards Information*  
 The following standards and equipment were used as references for this calibration.

Tested By	Date Tested	Insl. No.	Cal. Due	NIST Test Numbers
LOZADA	10/23/88	747	4/9/00	2593-4; 257802; 259800; 256692; 260222; 811255682;
		746	4/9/00	811255622; 811260176;
		922	6/8/00	536255547-93
		831	11/08/88	811257078 ; 247770 ; 263606 ; 811255674 ; 253639 ; USN22783C ; Chem Const. ; 254227 ; 811254736 ; 811251562 ; 251971 ; 811251741 ; 811253662 ; 811256216 ; 811822 ;
		657	6/8/00	836259947-98
		794	3/13/90	
		688	2/21/00	811266766 ; 251971 ; 811255004-80 ; 811257773 ; 256216 ;
		399	11/12/88	P-8531A ; P-8531B ; 38126 ; 254160 ; 2563002 ;
		325	2-4-99	P-8531A ; P-8531B ; 38126 ; 254160 ; 2590009 ;
		313	11/12/88	P-8531A ; P-8531B ; 38126 ; 254160 ; 2563002 ;
		301	12/11/88	835257126-96 ;

Alnor Instrument Company hereby certifies that the above designated equipment was found to meet or exceed manufacturing specifications. Their calibration is traceable to the National Institute of Standards and Technology (NIST) or national physical constants. The policies and procedures used comply with MIL-STD-45662A. This certificate shall not be reproduced except in full, without the written consent of Alnor.

Reviewed by: 

Date: 26-Oct-88

**ALNOR**  
 ATSP Company  
 Alnor Instrument Company  
 7555 W. Linder Avenue, Sicak, IL 60077  
 Tel. 847-677-3500 Fax. 847-677-3539





FILE NO. 040FB:001-19  
PAGE 1 OF 1

LETTER OF CERTIFICATION  
LAMINAR FLOW ELEMENT

CUSTOMER NAME: RESEARCH TRIANGLE INST  
CUSTOMER ORDER NUMBER: 00161  
MERIAM ORDER NUMBER: 772900

Meriam Instrument certifies that the completed LFE unit has been calibrated and correlated at several points of flow rate using a Meriam Standard, which is controlled per the calibration system requirements of ANSI Z540-1 and traceable to the National Institute of Standards and Technology. The collective uncertainty of the measurement standards has a 1:1 ratio to the acceptable tolerance for the flow rate being calibrated.

The total rss uncertainty of the completed laminar flow unit is +/- .72 % of reading.

CUSTOMER ID NO.: 013716

MODEL NO.: 50MH10-8 SERIAL NO.: 758860-K1

FLOW CURVE/TABLE NO.: 30624

DATE OF CALIBRATION 11-11-1998 BY GEORGE ROBOTKAY

AS RECEIVED CONDITION:  In Tolerance  Out of Tolerance  NA

AS LEFT CONDITION :  In Tolerance  Out of Tolerance  NA

CALIBRATION INTERVAL: TO BE DETERMINED BY CUSTOMER BASED ON USAGE OF LFE.

FLOW STANDARD SERIAL NO.	DATE OF LAST CAL	DATE OF NEXT CAL
WMMC2-6	JAN 1998	JAN 1999

The LFE unit listed hereon has been successfully calibrated in accordance with Meriam Instrument Procedure A-35822.

Michael V. ...  
QUALITY ASSURANCE INSPECTOR  
MERIAM INSTRUMENT

Jack Weigand  
QUALITY ASSURANCE MANAGER  
MERIAM INSTRUMENT

US EPA ARCHIVE DOCUMENT

**CLIMET INSTRUMENTS COMPANY**

1320 WEST COLTON AVE., REDLANDS, CA 92374 • PHONE: (909) 793-2788 • FAX: (909) 793-1738

**CERTIFICATE OF CALIBRATION**

**INSTRUMENT CALIBRATED**

MODEL: 226 aerosol particle counter, S/N 61882

CONTROL NUMBER: LCS23102

DATE CALIBRATED: 8/19/99 NEXT CALIBRATION: 2/19/2000

RECOMMENDED CALIBRATION INTERVAL: 6 months

L. Sparks  
CALIBRATED BY

John R. Griston  
APPROVED BY

**TRACEABILITY STATEMENT**

This instrument has been calibrated in accordance with ISO 10012-1/ANSI Z540-1 (which replaces MIL-STD-45662A) and relevant portions of Federal Standards 209, ASTM F-50, F322, and F328.

Temperature and Relative Humidity are not controlled during calibration because of the wide operating range of the instrument. The operating limits of this instrument are:

TEMPERATURE: 30°F TO 122°F  
HUMIDITY: 0-100%, non-condensing

All test equipment used in the calibration of Climet Instruments' products is calibrated at six-month intervals by an outside calibration service. Calibration certificates for each piece of test equipment are on file at Climet; copies will be supplied if requested.

Calibration traceability to a National Measurement Standard (NMS) is established by using mono-disperse latex spheres as a calibration standard. These spheres are sized by methods traceable, by lot number, to the National Institute of Science and Technology.

US EPA ARCHIVE DOCUMENT

**APPENDIX C**  
**Fractional Efficiency Data Sheets**

Key to notation used in the following tables:

Diam.:	Particle Diameter (µm)
Geo.:	Geometric
U. Bckgrnd:	The upstream background particle counts measured with the aerosol generator off.
Upstream:	The upstream particle counts measured with the aerosol generator on.
D. Bckgrnd:	The downstream background particle counts measured with the aerosol generator off.
Downstream:	The downstream particle counts measured with the aerosol generator on.
Meas. Penetration:	The penetration computed as:

$$\text{Meas. Penetration} = \frac{(\text{Downstream} \ \& \ D. \ \text{Bckgrnd})}{(\text{Upstream} \ \& \ U. \ \text{Bckgrnd})}$$

P100 Correction Values:	Penetration values measured with no filter in the test section. These values are used to correct subsequent penetration measurements for particle losses within the test duct and sampling system.
Corrected Penetration:	The measured penetration corrected by the P100 values:

$$\text{Corrected Penetration} = \frac{\text{Meas. Penetration}}{\text{P100 Correction Values}}$$

Corrected Efficiency (%):	100 x ( 1 - Corrected Penetration )
DQO	Data Quality Objective



Purolator DMK804404 and PB2424

Test No. 09099908  
 No Filter  
 Solid-Phase

Particle Counts per Indicated OPC Channel (1-Minute Samples @ 7.1 L/min)

OPC Channel Number	1	2	3	4	5	6	7	8	9	10	11	12	13	14	15
Min. Diam. (um)	0.45	0.59	0.73	0.80	1.02	1.44	1.86	2.28	2.85	3.13	4.25	5.66	7.07	7.77	9.88
Max. Diam. (um)	0.59	0.73	0.80	1.02	1.44	1.86	2.28	2.85	3.13	4.25	5.66	7.07	7.77	9.88	14.10
Geo. Mean Diam (um)	0.52	0.66	0.77	0.90	1.21	1.64	2.06	2.55	2.98	3.65	4.91	6.33	7.41	8.76	11.81

ENTER DATA BELOW

U. Bckgrnd	1	01	09-09-1999	13:29:55	01:00	0	0	0	0	0	0	0	0	0	0	0				
Upstream	1	01	09-09-1999	13:36:30	01:00	10040	14830	4609	8714	13340	7819	10660	10020	2447	5255	3190	1054	171	262	174
Upstream	1	01	09-09-1999	13:39:00	01:00	9830	14580	4645	8445	12780	7814	10010	9987	2316	5484	3151	1068	148	288	199
Upstream	1	01	09-09-1999	13:41:30	01:00	9637	14450	4617	8236	12440	7518	9959	9782	2395	5166	3157	1110	175	291	187
Upstream	1	01	09-09-1999	13:44:00	01:00	9833	14500	4550	8227	12720	7698	10080	9718	2417	5319	3131	1073	174	290	164
Upstream	1	01	09-09-1999	13:46:30	01:00	9491	14190	4571	8202	12440	7444	9831	9692	2362	5229	3123	1008	195	282	195
Upstream	1	01	09-09-1999	13:49:00	01:00	9576	14210	4613	8226	12560	7674	9842	9790	2452	5348	3154	1147	176	320	189
Upstream	1	01	09-09-1999	13:51:30	01:00	9709	14490	4605	8438	12960	7755	10070	9917	2436	5303	3247	1068	188	288	208
Upstream	1	01	09-09-1999	13:54:00	01:00	9786	14430	4538	8415	12840	7819	9962	9795	2400	5247	3193	1073	176	280	184
Upstream	1	01	09-09-1999	13:56:30	01:00	9645	14250	4600	8262	12690	7554	10080	9622	2391	5263	3224	1120	180	289	204
Upstream	1	01	09-09-1999	13:59:00	01:00	9330	14190	4485	8206	12450	7588	9821	9826	2405	5070	3124	1135	171	280	194
U. Bckgrnd	1	01	09-09-1999	14:11:52	01:00	0	0	0	0	0	0	0	0	0	0	0	0	0	0	0

ENTER DATA BELOW

D. Bckgrnd	2	01	09-09-1999	13:31:10	01:00	0	0	0	0	0	0	0	0	0	0	0	0	0	0	0
Downstream	2	01	09-09-1999	13:37:45	01:00	9727	14970	4790	8521	13390	7906	9970	9534	2342	5174	3191	1038	157	304	159
Downstream	2	01	09-09-1999	13:40:15	01:00	10020	14690	4597	8380	12990	7931	10350	10070	2465	5460	3236	1061	162	286	165
Downstream	2	01	09-09-1999	13:42:45	01:00	9534	14280	4594	8360	12450	7600	9905	9848	2388	5230	3160	1064	155	266	186
Downstream	2	01	09-09-1999	13:45:15	01:00	9487	14320	4500	8317	12640	7527	9849	9678	2384	5153	3107	1058	166	276	185
Downstream	2	01	09-09-1999	13:47:45	01:00	8905	13380	4264	7875	11930	7116	9407	9331	2303	4973	2920	1021	162	267	165
Downstream	2	01	09-09-1999	13:50:15	01:00	9651	14610	4751	8420	12860	7864	10200	9905	2387	5129	3159	1090	166	294	176
Downstream	2	01	09-09-1999	13:52:45	01:00	9475	14320	4460	8429	12990	7649	9725	9487	2383	5074	3065	1008	146	272	171
Downstream	2	01	09-09-1999	13:55:15	01:00	9735	14900	4602	8517	13280	7842	9940	9845	2347	5283	3201	1059	165	264	185
Downstream	2	01	09-09-1999	13:57:45	01:00	9682	14220	4591	8212	12650	7625	9906	9651	2389	5343	3165	1044	167	291	172
Downstream	2	01	09-09-1999	14:00:15	01:00	9485	14240	4578	8396	12690	7759	10090	10010	2391	5206	3205	1077	172	261	169
D. Bckgrnd	2	01	09-09-1999	14:13:07	01:00	2	2	0	0	0	0	0	0	0	0	0	0	0	0	0

Meas. Penetration	0.99	1.00	1.00	1.00	1.01	1.00	0.99	0.99	0.99	0.99	0.99	0.99	0.97	0.92	0.97	0.91
P100 correction values	1.00	1.00	1.00	1.00	1.00	1.00	1.00	1.00	1.00	1.00	1.00	1.00	1.00	1.00	1.00	1.00
Corrected Penetration	0.99	1.00	1.00	1.00	1.01	1.00	0.99	0.99	0.99	0.99	0.99	0.99	0.97	0.92	0.97	0.91
Corrected Efficiency (%)	1	0	0	0	-1	0	1	1	1	1	1	1	3	8	3	9

Data Acceptance Criteria:

Total Challenge Counts for Each Channel:	96877	144120	45833	83371	127220	76683	100315	98149	24021	52684	31694	10856	1754	2870	1898
Data Quality Objective:	> 500	> 500	> 500	> 500	> 500	> 500	> 500	> 500	> 500	> 500	> 500	> 500	> 500	> 500	> 500
Does this meet DQO:	Yes	Yes	Yes	Yes	Yes	Yes	Yes	Yes	Yes	Yes	Yes	Yes	Yes	Yes	Yes

Standard Deviation of Penetration for Each Channel :	0.04	0.03	0.03	0.03	0.04	0.04	0.04	0.03	0.02	0.03	0.03	0.04	0.08	0.07	0.08
Data Quality Objective:	<0.10	<0.10	<0.10	<0.10	<0.10	<0.10	<0.10	<0.10	<0.10	<0.30	<0.30	<0.30	<0.30	<0.30	<0.30
Does this meet DQO:	Yes	Yes	Yes	Yes	Yes	Yes	Yes	Yes	Yes	Yes	Yes	Yes	Yes	Yes	Yes

Maximum observed particle concentration (#/cc):	16.7
Data Quality Objective: max. allowable conc. (#/cc):	< 23
Does this meet the DQO:	Yes, (applies to all channels)

US EPA ARCHIVE DOCUMENT

Purolator DMK804404 and PB2424

Test No. 09099909  
Reference  
Solid-Phase

Particle Counts per Indicated OPC Channel (1-Minute Samples @ 7.1 L/min)

OPC Channel Number	1	2	3	4	5	6	7	8	9	10	11	12	13	14	15
Min. Diam. (um)	0.45	0.59	0.73	0.80	1.02	1.44	1.86	2.28	2.85	3.13	4.25	5.66	7.07	7.77	9.88
Max. Diam. (um)	0.59	0.73	0.80	1.02	1.44	1.86	2.28	2.85	3.13	4.25	5.66	7.07	7.77	9.88	14.10
Geo. Mean Diam (um)	0.52	0.66	0.77	0.90	1.21	1.64	2.06	2.55	2.98	3.65	4.91	6.33	7.41	8.76	11.81

ENTER DATA BELOW

U. Bckgrnd	1	01	09-09-1999	14:32:53	01:00	0	0	0	0	0	0	0	0	0	0	0				
Upstream	1	01	09-09-1999	14:40:44	01:00	9638	14490	4527	8339	12600	7554	9892	9580	2311	5054	3127	1110	147	281	176
Upstream	1	01	09-09-1999	14:43:14	01:00	9600	14610	4684	8232	12650	7702	10090	9955	2396	5382	3277	1117	176	275	197
Upstream	1	01	09-09-1999	14:45:44	01:00	9490	14300	4559	8337	12600	7599	9896	9764	2366	5196	3070	1061	181	300	202
Upstream	1	01	09-09-1999	14:48:14	01:00	9438	14270	4471	8206	12360	7474	9817	9938	2386	5204	3018	1123	175	262	192
Upstream	1	01	09-09-1999	14:50:44	01:00	9682	14600	4786	8467	12750	7711	10070	9859	2334	5326	3184	1090	193	284	210
Upstream	1	01	09-09-1999	14:53:14	01:00	9817	14740	4757	8542	12790	7800	10260	10030	2488	5236	3131	1142	187	294	195
Upstream	1	01	09-09-1999	14:55:44	01:00	9901	14570	4675	8641	13040	7669	10060	9924	2423	5217	3154	1123	188	277	197
Upstream	1	01	09-09-1999	14:58:14	01:00	9913	14790	4723	8613	12860	7904	10270	9909	2351	5180	3180	1103	189	328	173
Upstream	1	01	09-09-1999	15:00:44	01:00	9450	14180	4573	8286	12550	7499	9745	9696	2435	5184	3186	1097	184	286	197
Upstream	1	01	09-09-1999	15:03:14	01:00	9419	14030	4402	8115	12470	7323	9704	9365	2254	5052	3085	1098	192	279	199
U. Bckgrnd	1	01	09-09-1999	15:15:12	01:00	0	0	0	0	0	0	0	0	0	0	0	0	0	0	0

ENTER DATA BELOW

D. Bckgrnd	2	01	09-09-1999	14:34:08	01:00	0	0	0	0	0	0	0	0	0	0	0	0	0	0	0
Downstream	2	01	09-09-1999	14:41:59	01:00	9512	13940	4517	8035	12340	7345	9349	8958	2020	4094	1760	353	32	28	15
Downstream	2	01	09-09-1999	14:44:29	01:00	9445	14170	4490	8025	12060	6966	9378	8772	2113	4062	1762	357	27	33	24
Downstream	2	01	09-09-1999	14:46:59	01:00	9486	14220	4563	8195	12300	7379	9350	8964	2078	4060	1836	370	51	37	26
Downstream	2	01	09-09-1999	14:49:29	01:00	9356	14020	4458	8031	12070	7102	9379	8848	1988	4138	1831	346	30	41	18
Downstream	2	01	09-09-1999	14:51:59	01:00	9467	14000	4397	8132	12270	7233	9575	8734	1975	3913	1884	389	32	53	20
Downstream	2	01	09-09-1999	14:54:29	01:00	9696	14330	4384	8106	12560	7426	9502	8821	2034	3948	1774	382	35	33	15
Downstream	2	01	09-09-1999	14:56:59	01:00	9429	14330	4343	8258	12750	7349	9488	8944	1981	4135	1725	322	33	38	8
Downstream	2	01	09-09-1999	14:59:29	01:00	9337	13890	4440	8076	12320	7133	9282	8825	2036	4169	1823	361	25	37	15
Downstream	2	01	09-09-1999	15:01:59	01:00	9195	13700	4536	8093	11910	7106	9179	8879	2132	4020	1829	366	53	39	17
Downstream	2	01	09-09-1999	15:04:29	01:00	9106	13840	4355	7960	11670	7065	9175	8580	1992	3990	1743	347	38	37	11
D. Bckgrnd	2	01	09-09-1999	15:16:27	01:00	0	0	0	1	0	0	0	0	0	0	0	0	0	0	0

Meas. Penetration	0.98	0.97	0.96	0.97	0.97	0.95	0.94	0.90	0.86	0.78	0.57	0.32	0.20	0.13	0.09
P100 correction values	0.99	1.00	1.00	1.00	1.01	1.00	0.99	0.99	0.99	0.99	0.99	0.97	0.92	0.97	0.91
Corrected Penetration	0.99	0.97	0.97	0.97	0.96	0.94	0.95	0.91	0.87	0.79	0.58	0.34	0.21	0.14	0.10
Corrected Efficiency (%)	1	3	3	3	4	6	5	9	13	21	42	66	79	86	90

Data Acceptance Criteria:

Total Challenge Counts for Each Channel:	96348	144580	46157	83778	126670	76235	99804	98020	23744	52031	31412	11064	1812	2866	1938
Data Quality Objective:	> 500	> 500	> 500	> 500	> 500	> 500	> 500	> 500	> 500	> 500	> 500	> 500	> 500	> 500	> 500
Does this meet DQO:	Yes	Yes	Yes	Yes	Yes	Yes	Yes	Yes	Yes	Yes	Yes	Yes	Yes	Yes	Yes

Standard Deviation of Penetration for Each Channel :	0.03	0.02	0.03	0.02	0.03	0.03	0.02	0.02	0.03	0.02	0.02	0.02	0.02	0.05	0.02	0.03
Data Quality Objective:	<0.10	<0.10	<0.10	<0.10	<0.10	<0.10	<0.10	<0.10	<0.10	<0.30	<0.30	<0.30	<0.30	<0.30	<0.30	<0.30
Does this meet DQO:	Yes	Yes	Yes	Yes	Yes	Yes	Yes	Yes	Yes	Yes	Yes	Yes	Yes	Yes	Yes	Yes

Maximum observed particle concentration (#/cc):	16.5
Data Quality Objective: max. allowable conc. (#/cc):	< 23
Does this meet the DQO:	Yes, (applies to all channels)

US EPA ARCHIVE DOCUMENT

Purolator DMK804404 and PB2424

Test No. 09099906  
 No Filter  
 Solid-Phase

Particle Counts per Indicated OPC Channel (1-Minute Samples @ 7.1 L/min)

OPC Channel Number	1	2	3	4	5	6	7	8	9	10	11	12	13	14	15
Min. Diam. (um)	0.45	0.59	0.73	0.80	1.02	1.44	1.86	2.28	2.85	3.13	4.25	5.66	7.07	7.77	9.88
Max. Diam. (um)	0.59	0.73	0.80	1.02	1.44	1.86	2.28	2.85	3.13	4.25	5.66	7.07	7.77	9.88	14.10
Geo. Mean Diam (um)	0.52	0.66	0.77	0.90	1.21	1.64	2.06	2.55	2.98	3.65	4.91	6.33	7.41	8.76	11.81

ENTER DATA BELOW

U. Bckgrnd	1	01	09-09-1999	11:28:00	01:00	0	0	0	0	0	0	0	0	0	0	0				
Upstream	1	01	09-09-1999	11:43:28	01:00	11000	16080	5182	9263	14040	8598	11040	10750	2630	5609	3382	1138	174	262	161
Upstream	1	01	09-09-1999	11:45:58	01:00	9736	14450	4577	8524	12600	7937	10050	10140	2461	5386	3127	1029	177	287	157
Upstream	1	01	09-09-1999	11:48:28	01:00	9511	13870	4478	8063	12270	7472	9810	9504	2250	5145	3060	1022	173	266	175
Upstream	1	01	09-09-1999	11:50:58	01:00	9247	14190	4479	7966	12370	7472	9634	9638	2292	5206	3083	1032	170	284	174
Upstream	1	01	09-09-1999	11:53:28	01:00	9155	13860	4349	7871	11990	7189	9611	9592	2261	4994	3000	1046	178	292	170
Upstream	1	01	09-09-1999	11:55:58	01:00	9159	13700	4399	7920	11830	7080	9510	9405	2267	5028	2937	1024	177	244	171
Upstream	1	01	09-09-1999	11:58:28	01:00	9144	13520	4516	7921	12160	7387	9577	9497	2205	5155	2937	1062	179	296	200
Upstream	1	01	09-09-1999	12:00:58	01:00	9304	13550	4344	8022	12090	7296	9453	9369	2335	5058	2988	1063	169	299	200
Upstream	1	01	09-09-1999	12:03:28	01:00	9129	13590	4398	7804	12120	7391	9620	9417	2273	5091	3026	1011	186	273	163
Upstream	1	01	09-09-1999	12:05:58	01:00	9094	13270	4302	7777	11570	7065	9418	9246	2327	4961	3028	987	181	306	177
U. Bckgrnd	1	01	09-09-1999	12:13:57	01:00	0	0	0	0	0	1	0	0	0	0	0	0	0	0	0

ENTER DATA BELOW

D. Bckgrnd	2	01	09-09-1999	11:29:15	01:00	6	3	1	0	0	0	0	0	0	0	0	0	0	0	0
Downstream	2	01	09-09-1999	11:44:43	01:00	10770	15950	5107	9308	14110	8531	10820	10520	2583	5695	3309	1008	178	267	164
Downstream	2	01	09-09-1999	11:47:13	01:00	9401	14110	4514	8090	12850	7724	9784	9541	2399	5359	3215	1113	178	281	169
Downstream	2	01	09-09-1999	11:49:43	01:00	9546	13770	4406	8043	12310	7589	9861	9418	2325	4985	3056	946	159	275	177
Downstream	2	01	09-09-1999	11:52:13	01:00	9061	13760	4396	7832	11980	7201	9544	9133	2304	4901	3023	931	138	233	159
Downstream	2	01	09-09-1999	11:54:43	01:00	9205	13720	4270	7793	11880	7343	9668	9296	2223	5020	3034	1016	151	246	182
Downstream	2	01	09-09-1999	11:57:13	01:00	8973	13590	4342	7954	11950	7245	9513	9276	2249	5081	2908	961	145	241	140
Downstream	2	01	09-09-1999	11:59:43	01:00	9193	13830	4319	8054	12370	7317	9769	9442	2304	5072	2954	1013	173	242	169
Downstream	2	01	09-09-1999	12:02:13	01:00	9280	13750	4367	8071	12570	7229	9709	9443	2206	5002	3015	974	157	255	137
Downstream	2	01	09-09-1999	12:04:43	01:00	9363	13550	4357	8023	11990	7406	9879	9552	2248	5146	3093	1014	166	275	145
Downstream	2	01	09-09-1999	12:07:13	01:00	9043	13880	4379	7772	11770	7185	9417	9368	2277	4924	3030	969	145	265	177
D. Bckgrnd	2	01	09-09-1999	12:15:12	01:00	0	0	0	0	0	0	0	0	0	0	0	0	0	0	0

Meas. Penetration	0.99	1.00	0.99	1.00	1.01	1.00	1.00	0.98	0.99	0.99	1.00	0.95	0.90	0.92	0.93
P100 correction values	1.00	1.00	1.00	1.00	1.00	1.00	1.00	1.00	1.00	1.00	1.00	1.00	1.00	1.00	1.00
Corrected Penetration	0.99	1.00	0.99	1.00	1.01	1.00	1.00	0.98	0.99	0.99	1.00	0.95	0.90	0.92	0.93
Corrected Efficiency (%)	1	0	1	0	-1	0	0	2	1	1	0	5	10	8	7

Data Acceptance Criteria:

Total Challenge Counts for Each Channel:	94479	140080	45024	81131	123040	74887	97723	96558	23301	51633	30568	10414	1764	2809	1748
Data Quality Objective:	> 500	> 500	> 500	> 500	> 500	> 500	> 500	> 500	> 500	> 500	> 500	> 500	> 500	> 500	> 500
Does this meet DQO:	Yes	Yes	Yes	Yes	Yes	Yes	Yes	Yes	Yes	Yes	Yes	Yes	Yes	Yes	Yes

Standard Deviation of Penetration for Each Channel :	0.08	0.08	0.08	0.08	0.08	0.08	0.06	0.06	0.07	0.06	0.06	0.06	0.09	0.09	0.12
Data Quality Objective:	<0.10	<0.10	<0.10	<0.10	<0.10	<0.10	<0.10	<0.10	<0.10	< 0.30	< 0.30	< 0.30	< 0.30	< 0.30	< 0.30
Does this meet DQO:	Yes	Yes	Yes	Yes	Yes	Yes	Yes	Yes	Yes	Yes	Yes	Yes	Yes	Yes	Yes

Maximum observed particle concentration (#/cc):	17.9
Data Quality Objective: max. allowable conc. (#/cc):	< 23
Does this meet the DQO:	Yes, (applies to all channels)

Purolator DMK804404 and PB2424

Test No. 09099907  
 Arrestor  
 Solid-Phase

Particle Counts per Indicated OPC Channel (1-Minute Samples @ 7.1 L/min)

OPC Channel Number	1	2	3	4	5	6	7	8	9	10	11	12	13	14	15
Min. Diam. (um)	0.45	0.59	0.73	0.80	1.02	1.44	1.86	2.28	2.85	3.13	4.25	5.66	7.07	7.77	9.88
Max. Diam. (um)	0.59	0.73	0.80	1.02	1.44	1.86	2.28	2.85	3.13	4.25	5.66	7.07	7.77	9.88	14.10
Geo. Mean Diam (um)	0.52	0.66	0.77	0.90	1.21	1.64	2.06	2.55	2.98	3.65	4.91	6.33	7.41	8.76	11.81

ENTER DATA BELOW

U. Bckgrnd	1 01 09-09-1999 12:32:22 01:00	0	0	0	0	0	0	0	0	0	0	0	0	0	0	
Upstream	1 01 09-09-1999 12:38:55 01:00	9923	14600	4900	8514	13180	7816	10430	10380	2640	5696	3432	1135	214	306	191
Upstream	1 01 09-09-1999 12:41:25 01:00	9664	14040	4533	8395	12720	7549	9832	10190	2553	5623	3438	1121	221	358	201
Upstream	1 01 09-09-1999 12:43:55 01:00	9346	13790	4527	8079	12510	7501	9793	9823	2447	5395	3359	1160	209	287	184
Upstream	1 01 09-09-1999 12:46:25 01:00	9169	13930	4516	8164	12480	7521	9990	10000	2538	5528	3368	1173	217	311	201
Upstream	1 01 09-09-1999 12:48:55 01:00	9423	14140	4533	8163	12920	7461	9739	9987	2484	5352	3325	1170	202	317	220
Upstream	1 01 09-09-1999 12:51:25 01:00	9626	14030	4531	8466	12760	7639	10120	9950	2474	5407	3309	1188	190	315	209
Upstream	1 01 09-09-1999 12:53:55 01:00	8534	12910	4031	7473	11090	6796	8858	8640	2097	4575	2651	958	155	263	162
Upstream	1 01 09-09-1999 12:56:25 01:00	9666	14720	4577	8222	12840	7664	10000	10040	2391	5337	3149	1152	200	284	186
Upstream	1 01 09-09-1999 12:58:55 01:00	9347	14350	4543	8297	12410	7553	9832	9756	2326	5152	3149	1091	196	299	190
Upstream	1 01 09-09-1999 13:01:25 01:00	9712	14530	4705	8223	12370	7678	9927	10010	2446	5209	3179	1088	196	280	163
U. Bckgrnd	1 01 09-09-1999 13:11:55 01:00	0	0	0	0	0	0	0	0	0	0	0	0	0	0	

ENTER DATA BELOW

D. Bckgrnd	2 01 09-09-1999 12:33:37 01:00	3	2	0	0	0	0	0	0	0	0	0	0	0	0	
Downstream	2 01 09-09-1999 12:40:10 01:00	6058	8676	2684	4486	6130	3009	3443	2607	426	654	189	17	2	3	0
Downstream	2 01 09-09-1999 12:42:40 01:00	5756	8277	2376	4282	5650	2872	3303	2423	456	616	149	26	1	2	0
Downstream	2 01 09-09-1999 12:45:10 01:00	5943	8334	2621	4241	5830	2992	3269	2542	465	681	174	25	1	7	0
Downstream	2 01 09-09-1999 12:47:40 01:00	5652	8055	2465	4152	5641	2887	3127	2416	444	621	185	23	0	3	1
Downstream	2 01 09-09-1999 12:50:10 01:00	5765	8182	2468	4353	5969	2929	3202	2407	401	623	156	15	1	4	3
Downstream	2 01 09-09-1999 12:52:40 01:00	5916	8251	2447	4311	5985	2986	3144	2319	450	598	161	25	4	1	1
Downstream	2 01 09-09-1999 12:55:10 01:00	5860	8191	2431	4164	5811	2957	3183	2144	397	526	129	16	0	2	0
Downstream	2 01 09-09-1999 12:57:40 01:00	5831	8078	2490	4225	5647	2881	3128	2218	385	572	156	16	3	2	0
Downstream	2 01 09-09-1999 13:00:10 01:00	5939	8206	2498	4097	5761	2840	3117	2211	358	601	128	19	1	3	1
Downstream	2 01 09-09-1999 13:02:40 01:00	5881	8236	2421	4167	5560	2837	3134	2150	366	568	155	19	1	0	0
D. Bckgrnd	2 01 09-09-1999 13:13:10 01:00	1	0	0	0	2	0	0	0	0	0	0	0	0	0	

Meas. Penetration	0.62	0.58	0.55	0.52	0.46	0.39	0.33	0.24	0.17	0.11	0.05	0.02	0.01	0.01	0.00
P100 correction values	0.99	1.00	0.99	1.00	1.01	1.00	1.00	0.98	0.99	0.99	1.00	0.95	0.90	0.92	0.93
Corrected Penetration	0.62	0.59	0.56	0.52	0.46	0.39	0.32	0.24	0.17	0.11	0.05	0.02	0.01	0.01	0.00
Corrected Efficiency (%)	38	41	44	48	54	61	68	76	83	89	95	98	99	99	100

Data Acceptance Criteria:

Total Challenge Counts for Each Channel:	94410	141040	45396	81996	125280	75178	98521	98776	24396	53274	32359	11236	2000	3020	1907
Data Quality Objective:	> 500	> 500	> 500	> 500	> 500	> 500	> 500	> 500	> 500	> 500	> 500	> 500	> 500	> 500	> 500
Does this meet DQO:	Yes	Yes	Yes	Yes	Yes	Yes	Yes	Yes	Yes	Yes	Yes	Yes	Yes	Yes	Yes

Standard Deviation of Penetration for Each Channel :	0.03	0.02	0.03	0.02	0.03	0.02	0.02	0.02	0.02	0.01	0.01	0.00	0.01	0.01	0.01
Data Quality Objective:	<0.10	<0.10	<0.10	<0.10	<0.10	<0.10	<0.10	<0.10	<0.10	<0.30	<0.30	<0.30	<0.30	<0.30	<0.30
Does this meet DQO:	Yes	Yes	Yes	Yes	Yes	Yes	Yes	Yes	Yes	Yes	Yes	Yes	Yes	Yes	Yes

Maximum observed particle concentration (#/cc):	16.9
Data Quality Objective: max. allowable conc. (#/cc):	< 23
Does this meet the DQO:	Yes, (applies to all channels)

Purolator DMK804404 and PB2424

Test No. 09099910  
 No Filter  
 Solid-Phase

Particle Counts per Indicated OPC Channel (1-Minute Samples @ 7.1 L/min)

OPC Channel Number	1	2	3	4	5	6	7	8	9	10	11	12	13	14	15
Min. Diam. (um)	0.45	0.59	0.73	0.80	1.02	1.44	1.86	2.28	2.85	3.13	4.25	5.66	7.07	7.77	9.88
Max. Diam. (um)	0.59	0.73	0.80	1.02	1.44	1.86	2.28	2.85	3.13	4.25	5.66	7.07	7.77	9.88	14.10
Geo. Mean Diam (um)	0.52	0.66	0.77	0.90	1.21	1.64	2.06	2.55	2.98	3.65	4.91	6.33	7.41	8.76	11.81

ENTER DATA BELOW

U. Bckgrnd	1 01 09-09-1999 15:38:18 01:00	0	0	0	0	0	0	0	0	0	0	0	0	0	0	
Upstream	1 01 09-09-1999 15:46:07 01:00	9832	14830	4731	8602	13500	7996	10480	10310	2605	5501	3438	1169	196	301	173
Upstream	1 01 09-09-1999 15:48:37 01:00	9911	14390	4786	8422	13030	7894	10130	10310	2616	5544	3287	1115	188	304	199
Upstream	1 01 09-09-1999 15:51:07 01:00	9988	14750	4840	8746	13330	8080	10610	10350	2603	5823	3448	1236	187	322	184
Upstream	1 01 09-09-1999 15:53:37 01:00	9864	14750	4824	8775	13180	7963	10550	10460	2589	5529	3304	1228	193	310	187
Upstream	1 01 09-09-1999 15:56:07 01:00	9894	14940	4723	8853	13330	8128	10530	10620	2517	5702	3347	1172	186	296	224
Upstream	1 01 09-09-1999 15:58:37 01:00	10010	15170	4923	8886	13850	8144	10700	10650	2671	5537	3457	1251	210	341	205
Upstream	1 01 09-09-1999 16:01:07 01:00	9735	14640	4471	8208	12670	7668	9916	9449	2367	5224	3040	1044	183	271	165
Upstream	1 01 09-09-1999 16:03:37 01:00	9787	14800	4764	8692	13290	7811	10360	10000	2403	5348	3156	1101	179	283	193
Upstream	1 01 09-09-1999 16:06:07 01:00	9689	14880	4778	8440	12800	8072	10210	9946	2454	5332	3150	1101	188	306	170
Upstream	1 01 09-09-1999 16:08:37 01:00	9509	14260	4562	8429	12760	7627	10000	9561	2341	5075	3062	1093	158	245	180
U. Bckgrnd	1 01 09-09-1999 16:21:28 01:00	3	0	0	0	0	0	0	0	1	0	0	0	0	0	

ENTER DATA BELOW

D. Bckgrnd	2 01 09-09-1999 15:39:33 01:00	0	2	0	2	1	0	1	0	0	0	0	0	0	0	
Downstream	2 01 09-09-1999 15:47:22 01:00	9843	14220	4506	8623	13060	7797	10110	10180	2553	5598	3382	1144	179	314	198
Downstream	2 01 09-09-1999 15:49:52 01:00	9850	14760	4690	8555	13280	7913	10500	10420	2594	5631	3505	1211	191	310	214
Downstream	2 01 09-09-1999 15:52:22 01:00	9492	14180	4640	8467	12850	7538	9910	9910	2468	5450	3310	1128	168	300	184
Downstream	2 01 09-09-1999 15:54:52 01:00	9712	14590	4759	8714	13460	7948	10440	10450	2619	5657	3470	1177	147	325	180
Downstream	2 01 09-09-1999 15:57:22 01:00	9713	14530	4818	8793	13570	7940	10300	10520	2514	5597	3309	1098	201	294	163
Downstream	2 01 09-09-1999 15:59:52 01:00	9886	14780	4748	8781	13570	8098	10420	10110	2492	5491	3248	1159	178	292	204
Downstream	2 01 09-09-1999 16:02:22 01:00	10100	15000	4773	8833	13560	8238	10280	9672	2411	5446	3273	1049	193	267	184
Downstream	2 01 09-09-1999 16:04:52 01:00	9920	14530	4675	8652	13140	7855	10200	9822	2325	5209	3171	1066	160	298	179
Downstream	2 01 09-09-1999 16:07:22 01:00	9770	14320	4549	8267	12800	7875	10130	9857	2384	5121	3085	1068	161	299	162
Downstream	2 01 09-09-1999 16:09:52 01:00	9530	14150	4470	8467	12940	7680	9981	9754	2346	5241	3218	1089	155	290	187
D. Bckgrnd	2 01 09-09-1999 16:22:43 01:00	1	0	0	0	0	0	0	0	0	0	0	0	0	0	

Meas. Penetration	1.00	0.98	0.98	1.00	1.00	0.99	0.99	0.99	0.98	1.00	1.01	0.97	0.93	1.00	0.99
P100 correction values	1.00	1.00	1.00	1.00	1.00	1.00	1.00	1.00	1.00	1.00	1.00	1.00	1.00	1.00	1.00
Corrected Penetration	1.00	0.98	0.98	1.00	1.00	0.99	0.99	0.99	0.98	1.00	1.01	0.97	0.93	1.00	0.99
Corrected Efficiency (%)	0	2	2	0	0	1	1	1	2	0	-1	3	7	0	1

Data Acceptance Criteria:

Total Challenge Counts for Each Channel:	98219	147410	47402	86053	131740	79383	103486	101656	25166	54615	32689	11510	1868	2979	1880
Data Quality Objective:	> 500	> 500	> 500	> 500	> 500	> 500	> 500	> 500	> 500	> 500	> 500	> 500	> 500	> 500	> 500
Does this meet DQO:	Yes	Yes	Yes	Yes	Yes	Yes	Yes	Yes	Yes	Yes	Yes	Yes	Yes	Yes	Yes

Standard Deviation of Penetration for Each Channel :	0.02	0.03	0.04	0.03	0.04	0.03	0.03	0.05	0.06	0.05	0.06	0.08	0.12	0.10	0.13
Data Quality Objective:	<0.10	<0.10	<0.10	<0.10	<0.10	<0.10	<0.10	<0.10	<0.10	<0.30	<0.30	<0.30	<0.30	<0.30	<0.30
Does this meet DQO:	Yes	Yes	Yes	Yes	Yes	Yes	Yes	Yes	Yes	Yes	Yes	Yes	Yes	Yes	Yes

Maximum observed particle concentration (#/cc):	17.3
Data Quality Objective: max. allowable conc. (#/cc):	< 23
Does this meet the DQO:	Yes, (applies to all channels)

Purolator DMK804404 and PB2424

Test No. 09099911  
 Arrestor  
 Solid-Phase

Particle Counts per Indicated OPC Channel (1-Minute Samples @ 7.1 L/min)

OPC Channel Number	1	2	3	4	5	6	7	8	9	10	11	12	13	14	15
Min. Diam. (um)	0.45	0.59	0.73	0.80	1.02	1.44	1.86	2.28	2.85	3.13	4.25	5.66	7.07	7.77	9.88
Max. Diam. (um)	0.59	0.73	0.80	1.02	1.44	1.86	2.28	2.85	3.13	4.25	5.66	7.07	7.77	9.88	14.10
Geo. Mean Diam (um)	0.52	0.66	0.77	0.90	1.21	1.64	2.06	2.55	2.98	3.65	4.91	6.33	7.41	8.76	11.81

ENTER DATA BELOW

U. Bckgrnd	1 01 09-09-1999 16:42:05 01:00	0	0	0	0	0	0	0	0	0	0	0	0	0	0	
Upstream	1 01 09-09-1999 16:48:38 01:00	9870	14760	4632	8612	13120	7985	10230	9793	2296	5202	3059	1072	178	276	202
Upstream	1 01 09-09-1999 16:51:08 01:00	9875	14730	4749	8659	12900	7774	10370	9840	2276	5383	3198	1132	154	272	203
Upstream	1 01 09-09-1999 16:53:38 01:00	9591	14450	4699	8363	12720	7709	10040	9607	2496	5169	3171	1111	160	277	209
Upstream	1 01 09-09-1999 16:56:08 01:00	9546	14380	4527	8211	12420	7737	9882	9470	2322	5196	3081	1062	188	275	190
Upstream	1 01 09-09-1999 16:58:38 01:00	9667	14530	4610	8541	12660	7803	9971	9648	2343	5086	3178	1070	170	276	210
Upstream	1 01 09-09-1999 17:01:08 01:00	9702	14770	4691	8785	13170	7994	10150	9758	2372	5137	3196	1090	177	290	203
Upstream	1 01 09-09-1999 17:03:38 01:00	9229	13650	4597	8026	12760	7498	9741	9744	2378	5278	3284	1134	191	282	182
Upstream	1 01 09-09-1999 17:06:08 01:00	9855	14810	4773	8959	13650	8060	10550	10310	2496	5569	3458	1232	206	291	215
Upstream	1 01 09-09-1999 17:08:38 01:00	9750	14280	4630	8656	13390	7686	10290	10190	2503	5580	3534	1189	209	297	195
Upstream	1 01 09-09-1999 17:11:08 01:00	9185	13710	4455	8061	12780	7628	10010	9708	2480	5346	3360	1155	200	338	203
U. Bckgrnd	1 01 09-09-1999 17:21:27 01:00	1	3	0	0	2	0	0	0	2	0	0	0	0	0	0

ENTER DATA BELOW

D. Bckgrnd	2 01 09-09-1999 16:43:20 01:00	0	1	0	0	0	1	0	0	0	0	0	0	0	0	0
Downstream	2 01 09-09-1999 16:49:53 01:00	5963	8897	2692	4377	6180	3012	3083	2009	300	498	120	6	1	0	0
Downstream	2 01 09-09-1999 16:52:23 01:00	5959	8286	2505	4282	5770	2868	3172	2108	345	482	98	13	1	2	0
Downstream	2 01 09-09-1999 16:54:53 01:00	5927	8379	2434	4214	5604	2954	2993	2200	324	505	135	5	2	0	0
Downstream	2 01 09-09-1999 16:57:23 01:00	5968	8382	2474	4259	5672	2947	2944	2049	312	493	109	12	0	2	0
Downstream	2 01 09-09-1999 16:59:53 01:00	6060	8420	2433	4215	5699	2840	3126	2091	331	456	117	12	1	1	0
Downstream	2 01 09-09-1999 17:02:23 01:00	5962	8334	2382	4200	5908	2952	3115	2062	319	469	113	13	0	1	0
Downstream	2 01 09-09-1999 17:04:53 01:00	5926	8389	2508	4435	6119	3042	3287	2239	401	560	126	20	1	1	1
Downstream	2 01 09-09-1999 17:07:23 01:00	6168	8811	2557	4673	6287	3132	3395	2287	346	568	136	13	2	0	0
Downstream	2 01 09-09-1999 17:09:53 01:00	5667	7832	2400	4146	5576	2792	3207	2249	427	579	135	12	3	4	3
Downstream	2 01 09-09-1999 17:12:23 01:00	5892	7933	2459	4353	5877	2926	3311	2324	380	551	158	16	3	2	2
D. Bckgrnd	2 01 09-09-1999 17:22:42 01:00	0	0	0	0	1	0	0	0	0	0	0	0	0	0	0

Meas. Penetration	0.62	0.58	0.54	0.51	0.45	0.38	0.31	0.22	0.15	0.10	0.04	0.01	0.01	0.01	0.00	0.00
P100 correction values	1.00	0.98	0.98	1.00	1.00	0.99	0.99	0.99	0.98	1.00	1.01	0.97	0.93	1.00	0.99	
Corrected Penetration	0.62	0.59	0.54	0.51	0.45	0.38	0.32	0.22	0.15	0.10	0.04	0.01	0.01	0.00	0.00	
Corrected Efficiency (%)	38	41	46	49	55	62	68	78	85	90	96	99	99	100	100	

Data Acceptance Criteria:

Total Challenge Counts for Each Channel:	96270	144070	46363	84873	129570	77874	101234	98068	23962	52946	32519	11247	1833	2874	2012
Data Quality Objective:	> 500	> 500	> 500	> 500	> 500	> 500	> 500	> 500	> 500	> 500	> 500	> 500	> 500	> 500	> 500
Does this meet DQO:	Yes	Yes	Yes	Yes	Yes	Yes	Yes	Yes	Yes	Yes	Yes	Yes	Yes	Yes	Yes

Standard Deviation of Penetration for Each Channel :	0.02	0.03	0.02	0.03	0.02	0.02	0.02	0.01	0.02	0.01	0.01	0.00	0.01	0.00	0.01
Data Quality Objective:	<0.10	<0.10	<0.10	<0.10	<0.10	<0.10	<0.10	<0.10	<0.10	<0.30	<0.30	<0.30	<0.30	<0.30	<0.30
Does this meet DQO:	Yes	Yes	Yes	Yes	Yes	Yes	Yes	Yes	Yes	Yes	Yes	Yes	Yes	Yes	Yes

Maximum observed particle concentration (#/cc):	17.1
Data Quality Objective: max. allowable conc. (#/cc):	< 23
Does this meet the DQO:	Yes, (applies to all channels)

Purolator DMK804404 and PB2424

Test No. 09109901  
 No Filter  
 Solid-Phase

Particle Counts per Indicated OPC Channel (1-Minute Samples @ 7.1 L/min)

OPC Channel Number	1	2	3	4	5	6	7	8	9	10	11	12	13	14	15
Min. Diam. (um)	0.45	0.59	0.73	0.80	1.02	1.44	1.86	2.28	2.85	3.13	4.25	5.66	7.07	7.77	9.88
Max. Diam. (um)	0.59	0.73	0.80	1.02	1.44	1.86	2.28	2.85	3.13	4.25	5.66	7.07	7.77	9.88	14.10
Geo. Mean Diam (um)	0.52	0.66	0.77	0.90	1.21	1.64	2.06	2.55	2.98	3.65	4.91	6.33	7.41	8.76	11.81

ENTER DATA BELOW

U. Bckgrnd	1 01 09-10-1999 06:56:30 01:00	0	0	0	0	0	0	0	0	0	0	0	0	0	0	
Upstream	1 01 09-10-1999 07:26:51 01:00	9811	14510	4605	8422	12580	7725	9785	9898	2356	5324	3020	878	129	219	148
Upstream	1 01 09-10-1999 07:29:21 01:00	10120	15060	4661	8437	12810	7689	10140	10280	2404	5388	3076	1011	147	291	173
Upstream	1 01 09-10-1999 07:31:51 01:00	10090	14850	4661	8235	12710	7575	9987	10150	2497	5337	3085	998	145	257	161
Upstream	1 01 09-10-1999 07:34:21 01:00	10450	15650	4849	8765	13170	8039	10560	10660	2494	5433	3035	1020	181	281	153
Upstream	1 01 09-10-1999 07:36:51 01:00	10150	14980	4852	8753	13420	7986	10670	10380	2471	5401	3159	1036	140	236	166
Upstream	1 01 09-10-1999 07:39:21 01:00	9425	13750	4499	8265	12360	7500	9739	9912	2473	5477	3213	991	176	257	166
Upstream	1 01 09-10-1999 07:41:51 01:00	10150	14900	4779	8856	13530	8063	10260	10590	2592	5851	3339	1111	157	333	213
Upstream	1 01 09-10-1999 07:44:21 01:00	10040	14760	4753	8756	13230	7898	10300	10670	2652	5756	3352	1133	178	291	185
Upstream	1 01 09-10-1999 07:46:51 01:00	10210	14910	4853	8782	13600	8193	10560	11200	2720	5857	3432	1107	188	277	208
Upstream	1 01 09-10-1999 07:49:21 01:00	10310	15300	4882	8885	13760	8211	10630	11010	2771	5940	3389	1046	170	285	197
U. Bckgrnd	1 01 09-10-1999 08:02:16 01:00	2	0	0	0	0	0	0	0	0	0	0	0	0	0	

ENTER DATA BELOW

D. Bckgrnd	2 01 09-10-1999 06:57:45 01:00	0	0	0	0	0	0	0	0	0	0	0	0	0	0	
Downstream	2 01 09-10-1999 07:28:06 01:00	10190	15200	4828	8603	12940	7667	10280	10380	2499	5485	2993	958	138	209	154
Downstream	2 01 09-10-1999 07:30:36 01:00	10120	14750	4935	8258	12710	7850	10210	10110	2352	5128	2955	924	150	234	151
Downstream	2 01 09-10-1999 07:33:06 01:00	10080	15030	4754	8655	12960	8019	10310	10220	2474	5317	2984	962	147	234	154
Downstream	2 01 09-10-1999 07:35:36 01:00	10100	14690	4588	8645	13060	7724	10280	10050	2369	5236	3041	984	159	209	160
Downstream	2 01 09-10-1999 07:38:06 01:00	10400	15370	4832	8857	13320	8068	10520	10140	2484	5281	3071	924	152	238	144
Downstream	2 01 09-10-1999 07:40:36 01:00	10380	15330	4901	8895	14160	8371	10600	10810	2691	5900	3378	1020	175	288	148
Downstream	2 01 09-10-1999 07:43:06 01:00	10080	14910	4789	8749	13600	7954	10430	10840	2730	5723	3375	1078	159	263	167
Downstream	2 01 09-10-1999 07:45:36 01:00	10150	14920	4822	8816	13420	7986	10440	10640	2646	5723	3335	1115	179	281	171
Downstream	2 01 09-10-1999 07:48:06 01:00	9834	15160	4951	8987	13870	8112	10520	10830	2766	5786	3304	1060	168	287	184
Downstream	2 01 09-10-1999 07:50:36 01:00	10310	15380	4749	9130	13930	8246	10700	10680	2693	5847	3314	1167	170	259	179
D. Bckgrnd	2 01 09-10-1999 08:03:31 01:00	0	0	0	0	0	0	0	0	0	0	0	0	0	0	

Meas. Penetration	1.01	1.01	1.02	1.02	1.02	1.01	1.02	1.00	1.01	0.99	0.99	0.99	0.99	0.92	0.91
P100 correction values	1.00	1.00	1.00	1.00	1.00	1.00	1.00	1.00	1.00	1.00	1.00	1.00	1.00	1.00	1.00
Corrected Penetration	1.01	1.01	1.02	1.02	1.02	1.01	1.02	1.00	1.01	0.99	0.99	0.99	0.99	0.92	0.91
Corrected Efficiency (%)	-1	-1	-2	-2	-2	-1	-2	0	-1	1	1	1	1	8	9

Data Acceptance Criteria:

Total Challenge Counts for Each Channel:	100756	148670	47394	86156	131170	78879	102631	104750	25430	55764	32100	10331	1611	2727	1770
Data Quality Objective:	> 500	> 500	> 500	> 500	> 500	> 500	> 500	> 500	> 500	> 500	> 500	> 500	> 500	> 500	> 500
Does this meet DQO:	Yes	Yes	Yes	Yes	Yes	Yes	Yes	Yes	Yes	Yes	Yes	Yes	Yes	Yes	Yes

Standard Deviation of Penetration for Each Channel :	0.03	0.04	0.04	0.04	0.05	0.04	0.04	0.05	0.08	0.07	0.07	0.11	0.15	0.15	0.14
Data Quality Objective:	<0.10	<0.10	<0.10	<0.10	<0.10	<0.10	<0.10	<0.10	<0.10	<0.30	<0.30	<0.30	<0.30	<0.30	<0.30
Does this meet DQO:	Yes	Yes	Yes	Yes	Yes	Yes	Yes	Yes	Yes	Yes	Yes	Yes	Yes	Yes	Yes

Maximum observed particle concentration (#/cc): 17.5  
 Data Quality Objective: max. allowable conc. (#/cc): < 23  
 Does this meet the DQO: Yes, (applies to all channels)

Test No. 09109902  
 Arrestor  
 Solid-Phase

Particle Counts per Indicated OPC Channel (1-Minute Samples @ 7.1 L/min)

OPC Channel Number	1	2	3	4	5	6	7	8	9	10	11	12	13	14	15
Min. Diam. (um)	0.45	0.59	0.73	0.80	1.02	1.44	1.86	2.28	2.85	3.13	4.25	5.66	7.07	7.77	9.88
Max. Diam. (um)	0.59	0.73	0.80	1.02	1.44	1.86	2.28	2.85	3.13	4.25	5.66	7.07	7.77	9.88	14.10
Geo. Mean Diam (um)	0.52	0.66	0.77	0.90	1.21	1.64	2.06	2.55	2.98	3.65	4.91	6.33	7.41	8.76	11.81

ENTER DATA BELOW

U. Bckgrnd	1 01 09-10-1999 08:23:21 01:00	2	1	1	0	0	0	0	0	0	0	0	0	0	0	
Upstream	1 01 09-10-1999 08:29:58 01:00	9942	14420	4687	8532	12860	7666	10120	10060	2490	5257	3095	1061	142	223	175
Upstream	1 01 09-10-1999 08:32:28 01:00	9961	14570	4622	8417	12610	7775	10100	10170	2476	5415	3234	1025	166	266	166
Upstream	1 01 09-10-1999 08:34:58 01:00	10150	14950	4869	8600	13060	7888	10430	10490	2609	5405	3071	1011	159	259	179
Upstream	1 01 09-10-1999 08:37:28 01:00	9853	15140	4739	8714	13480	8034	10410	10640	2560	5513	3151	1013	169	281	161
Upstream	1 01 09-10-1999 08:39:58 01:00	10150	15190	4918	8769	13270	8168	10470	10700	2585	5602	3314	949	166	272	178
Upstream	1 01 09-10-1999 08:42:28 01:00	10200	15250	4822	8718	13680	8097	10740	10760	2580	5624	3178	1079	171	268	178
Upstream	1 01 09-10-1999 08:44:58 01:00	10290	15460	4924	8946	13950	8091	10460	10670	2655	5812	3360	1119	187	257	177
Upstream	1 01 09-10-1999 08:47:28 01:00	10800	15690	5061	9103	14080	8373	10940	10790	2664	5814	3325	1067	173	283	175
Upstream	1 01 09-10-1999 08:49:58 01:00	10170	15110	4984	8821	13660	8172	10480	10680	2693	5717	3205	1071	160	289	186
Upstream	1 01 09-10-1999 08:52:28 01:00	10380	15550	4912	8968	13520	8076	10580	10770	2627	5797	3312	1062	158	289	189
U. Bckgrnd	1 01 09-10-1999 09:03:45 01:00	0	0	0	0	0	0	0	0	0	0	0	0	0	0	

ENTER DATA BELOW

D. Bckgrnd	2 01 09-10-1999 08:24:36 01:00	0	0	0	0	0	0	0	0	0	0	0	0	0	0	
Downstream	2 01 09-10-1999 08:31:13 01:00	6139	8536	2506	4379	5817	2928	3353	2357	384	594	128	10	1	0	0
Downstream	2 01 09-10-1999 08:33:43 01:00	6430	8847	2752	4653	6221	3060	3524	2557	411	636	169	22	2	3	2
Downstream	2 01 09-10-1999 08:36:13 01:00	6429	8988	2669	4529	6223	3226	3576	2522	412	608	157	27	4	0	1
Downstream	2 01 09-10-1999 08:38:43 01:00	6521	9101	2666	4659	6303	3272	3537	2555	446	638	167	23	5	0	2
Downstream	2 01 09-10-1999 08:41:13 01:00	6632	9093	2712	4700	6349	3154	3633	2656	421	651	157	18	2	1	0
Downstream	2 01 09-10-1999 08:43:43 01:00	6501	9282	2603	4720	6365	3207	3495	2528	424	616	129	6	1	2	2
Downstream	2 01 09-10-1999 08:46:13 01:00	6495	9399	2718	4915	6649	3295	3659	2549	440	637	131	20	3	2	2
Downstream	2 01 09-10-1999 08:48:43 01:00	6476	8992	2678	4557	6325	3163	3409	2517	420	630	160	15	1	1	1
Downstream	2 01 09-10-1999 08:51:13 01:00	6610	9225	2831	4612	6280	3248	3595	2485	491	661	150	28	4	2	2
Downstream	2 01 09-10-1999 08:53:43 01:00	6679	9112	2792	4679	6343	3304	3610	2547	414	667	173	24	2	4	0
D. Bckgrnd	2 01 09-10-1999 09:05:00 01:00	0	0	0	0	0	0	0	0	0	3	0	0	0	0	

Meas. Penetration	0.64	0.60	0.55	0.53	0.47	0.40	0.34	0.24	0.16	0.11	0.05	0.02	0.02	0.01	0.01
P100 correction values	1.01	1.01	1.02	1.02	1.02	1.01	1.02	1.00	1.01	0.99	0.99	0.99	0.99	0.92	0.91
Corrected Penetration	0.63	0.59	0.55	0.52	0.46	0.39	0.33	0.24	0.16	0.11	0.05	0.02	0.02	0.01	0.01
Corrected Efficiency (%)	37	41	45	48	54	61	67	76	84	89	95	98	98	99	99

Data Acceptance Criteria:

Total Challenge Counts for Each Channel:	101896	151330	48538	87588	134170	80340	104730	105730	25939	55956	32245	10457	1651	2687	1764
Data Quality Objective:	> 500	> 500	> 500	> 500	> 500	> 500	> 500	> 500	> 500	> 500	> 500	> 500	> 500	> 500	> 500
Does this meet DQO:	Yes	Yes	Yes	Yes	Yes	Yes	Yes	Yes	Yes	Yes	Yes	Yes	Yes	Yes	Yes

Standard Deviation of Penetration for Each Channel :	0.02	0.02	0.02	0.02	0.02	0.02	0.01	0.01	0.01	0.01	0.01	0.01	0.01	0.01	0.01
Data Quality Objective:	<0.10	<0.10	<0.10	<0.10	<0.10	<0.10	<0.10	<0.10	<0.10	<0.30	<0.30	<0.30	<0.30	<0.30	<0.30
Does this meet DQO:	Yes	Yes	Yes	Yes	Yes	Yes	Yes	Yes	Yes	Yes	Yes	Yes	Yes	Yes	Yes

Maximum observed particle concentration (#/cc):	17.8
Data Quality Objective: max. allowable conc. (#/cc):	< 23
Does this meet the DQO:	Yes, (applies to all channels)

US EPA ARCHIVE DOCUMENT



Purolator DMK804404 and PB2424

Test No. 08319904

HEPA  
Solid-Phase

Particle Counts per Indicated OPC Channel (1-Minute Samples @ 7.1 L/min)

OPC Channel Number	1	2	3	4	5	6	7	8	9	10	11	12	13	14	15
Min. Diam. (um)	0.45	0.59	0.73	0.80	1.02	1.44	1.86	2.28	2.85	3.13	4.25	5.66	7.07	7.77	9.88
Max. Diam. (um)	0.59	0.73	0.80	1.02	1.44	1.86	2.28	2.85	3.13	4.25	5.66	7.07	7.77	9.88	14.10
Geo. Mean Diam (um)	0.52	0.66	0.77	0.90	1.21	1.64	2.06	2.55	2.98	3.65	4.91	6.33	7.41	8.76	11.81

ENTER DATA BELOW

U. Bckgrnd	1 01 08-31-1999 13:21:20	01:00	0	0	0	0	0	0	0	0	0	0	0	0	0	0	
Upstream	1 01 08-31-1999 13:30:30	01:00	9906	15210	4721	8631	13060	7586	10050	11040	2743	5920	3442	1149	191	297	193
Upstream	1 01 08-31-1999 13:33:00	01:00	10140	15260	4804	8950	13360	7959	10180	11250	2837	6030	3564	1170	200	303	204
Upstream	1 01 08-31-1999 13:35:30	01:00	10410	15560	4867	9101	13840	8060	10440	11550	2828	6156	3569	1175	204	309	222
Upstream	1 01 08-31-1999 13:38:00	01:00	10020	14890	4814	8556	13350	7905	10220	11320	2790	6017	3444	1167	201	320	176
Upstream	1 01 08-31-1999 13:40:30	01:00	10100	14850	4829	8570	13280	7877	10120	11290	2726	5961	3453	1288	211	336	209
Upstream	1 01 08-31-1999 13:43:00	01:00	9782	14920	4769	8396	12730	7719	10000	11070	2828	5833	3446	1167	174	328	218
Upstream	1 01 08-31-1999 13:45:30	01:00	8866	13340	4235	7393	11380	6768	8732	9584	2284	5022	2752	939	160	254	147
Upstream	1 01 08-31-1999 13:48:00	01:00	9952	14880	4725	8314	12550	7560	9809	10470	2506	5235	3100	1034	182	302	179
Upstream	1 01 08-31-1999 13:50:30	01:00	10040	14910	4738	8308	12870	7608	9800	10540	2540	5386	3184	1015	158	261	187
Upstream	1 01 08-31-1999 13:53:00	01:00	9933	14870	4601	8359	12770	7614	9846	10330	2503	5398	3046	1069	168	289	189
U. Bckgrnd	1 01 08-31-1999 14:03:28	01:00	0	0	0	0	0	0	0	0	0	0	0	0	0	0	0

ENTER DATA BELOW

D. Bckgrnd	2 01 08-31-1999 13:22:35	01:00	0	0	0	0	0	0	0	0	0	0	0	0	0	0	0
Downstream	2 01 08-31-1999 13:31:45	01:00	12	21	2	11	12	6	10	9	6	2	1	1	0	0	0
Downstream	2 01 08-31-1999 13:34:15	01:00	10	14	3	9	17	8	13	13	2	1	5	0	0	0	0
Downstream	2 01 08-31-1999 13:36:45	01:00	8	19	4	5	14	8	17	10	1	7	0	2	0	0	1
Downstream	2 01 08-31-1999 13:39:15	01:00	7	14	6	10	14	10	8	7	1	5	0	2	0	0	0
Downstream	2 01 08-31-1999 13:41:45	01:00	9	18	4	8	15	8	5	4	1	5	1	0	0	0	0
Downstream	2 01 08-31-1999 13:44:15	01:00	12	17	2	7	19	11	11	9	0	8	1	1	0	0	0
Downstream	2 01 08-31-1999 13:46:45	01:00	5	20	4	5	13	7	9	7	3	3	2	0	0	0	0
Downstream	2 01 08-31-1999 13:49:15	01:00	12	16	5	6	11	4	9	6	2	2	4	0	0	0	0
Downstream	2 01 08-31-1999 13:51:45	01:00	9	17	5	10	5	10	7	6	3	8	0	0	0	0	0
Downstream	2 01 08-31-1999 13:54:15	01:00	7	20	1	6	16	9	8	11	1	3	2	0	0	0	0
D. Bckgrnd	2 01 08-31-1999 14:04:43	01:00	0	2	0	2	1	0	2	2	1	1	0	0	0	0	0

Meas. Penetration	0.00	0.00	0.00	0.00	0.00	0.00	0.00	0.00	0.00	0.00	0.00	0.00	0.00	0.00	0.00	0.00	0.00
P100 correction values	1.01	1.00	1.01	1.00	1.01	1.01	1.02	1.03	0.99	1.01	1.01	1.01	1.01	0.95	0.88		
Corrected Penetration	0.00	0.00	0.00	0.00	0.00	0.00	0.00	0.00	0.00	0.00	0.00	0.00	0.00	0.00	0.00	0.00	0.00
Corrected Efficiency (%)	100	100	100	100	100	100	100	100	100	100	100	100	100	100	100	100	100

Data Acceptance Criteria:

Total Challenge Counts for Each Channel:	99149	148690	47103	84578	129190	76656	99197	108444	26585	56958	33000	11173	1849	2999	1924
Data Quality Objective:	> 500	> 500	> 500	> 500	> 500	> 500	> 500	> 500	> 500	> 500	> 500	> 500	> 500	> 500	> 500
Does this meet DQO:	Yes	Yes	Yes	Yes	Yes	Yes	Yes	Yes	Yes	Yes	Yes	Yes	Yes	Yes	Yes

Standard Deviation of Penetration for Each Channel :	0.00	0.00	0.00	0.00	0.00	0.00	0.00	0.00	0.00	0.00	0.00	0.00	0.00	0.00	0.00
Data Quality Objective:	<0.10	<0.10	<0.10	<0.10	<0.10	<0.10	<0.10	<0.10	<0.10	<0.30	<0.30	<0.30	<0.30	<0.30	<0.30
Does this meet DQO:	Yes	Yes	Yes	Yes	Yes	Yes	Yes	Yes	Yes	Yes	Yes	Yes	Yes	Yes	Yes

Maximum observed particle concentration (#/cc):	17.7
Data Quality Objective: max. allowable conc. (#/cc):	< 23
Does this meet the DQO:	Yes, (applies to all channels)

US EPA ARCHIVE DOCUMENT

Test No. 09089908  
 No Filter  
 Liquid-Phase

Particle Counts per Indicated OPC Channel (1-Minute Samples @ 7.1 L/min)

OPC Channel Number	1	2	3	4	5	6	7	8	9	10	11	12	13	14	15
Min. Diam. (um)	0.28	0.37	0.47	0.52	0.66	0.94	1.22	1.51	1.88	2.07	2.83	3.77	4.71	5.18	6.60
Max. Diam. (um)	0.37	0.47	0.52	0.66	0.94	1.22	1.51	1.88	2.07	2.83	3.77	4.71	5.18	6.60	9.43
Geo. Mean Diam (um)	0.32	0.42	0.49	0.58	0.78	1.07	1.36	1.68	1.97	2.42	3.26	4.21	4.94	5.85	7.89
ENTER DATA BELOW															
U. Bckgrnd	1 01 09-08-1999 14:11:20 01:00	0	0	0	0	0	0	0	0	0	0	0	0	0	0
Upstream	1 01 09-08-1999 14:20:30 01:00	9891	15130	5338	9932	15060	10450	17560	13770	2965	7180	4374	1125	178	273
Upstream	1 01 09-08-1999 14:23:00 01:00	9796	14870	5140	9674	14980	10280	17050	13460	2934	7111	4165	1207	180	282
Upstream	1 01 09-08-1999 14:25:30 01:00	10000	14800	5192	9837	14720	9998	16800	13450	3025	6997	4347	1118	161	273
Upstream	1 01 09-08-1999 14:28:00 01:00	9861	14780	5194	9503	14930	9989	16660	13570	2926	7079	4412	1128	162	304
Upstream	1 01 09-08-1999 14:30:30 01:00	9455	14390	5048	9520	14170	9622	16240	12970	2898	7091	4265	1090	166	256
Upstream	1 01 09-08-1999 14:33:00 01:00	9444	14450	5068	9622	14010	9746	16290	13210	2886	6906	4176	1099	190	265
Upstream	1 01 09-08-1999 14:35:30 01:00	8328	12930	4579	8336	12440	8914	14680	11080	2548	5904	3507	878	149	225
Upstream	1 01 09-08-1999 14:38:00 01:00	9208	14580	5251	9246	14240	10010	16460	12350	2766	6640	3868	1024	159	260
Upstream	1 01 09-08-1999 14:40:30 01:00	9480	14650	5101	9381	14230	9935	16550	12430	2767	6619	3918	1039	163	255
Upstream	1 01 09-08-1999 14:43:00 01:00	9126	14420	4870	9264	14120	10030	16390	12500	2754	6530	3937	1017	141	231
U. Bckgrnd	1 01 09-08-1999 14:53:00 01:00	0	0	0	0	0	0	0	0	0	0	0	0	0	0
ENTER DATA BELOW															
D. Bckgrnd	2 01 09-08-1999 14:12:35 01:00	3	0	0	0	0	1	0	0	0	0	0	0	0	0
Downstream	2 01 09-08-1999 14:21:45 01:00	9904	14820	5096	9659	14830	10030	16600	13300	3002	6906	4196	1064	140	212
Downstream	2 01 09-08-1999 14:24:15 01:00	9781	14620	5330	9809	14790	10060	16780	13430	2950	6942	4258	1107	139	223
Downstream	2 01 09-08-1999 14:26:45 01:00	9545	14480	5088	9377	14240	9718	16320	13120	2859	6851	4179	1061	152	241
Downstream	2 01 09-08-1999 14:29:15 01:00	9986	14830	5252	9762	14740	10120	16580	13820	2999	7192	4295	1079	166	229
Downstream	2 01 09-08-1999 14:31:45 01:00	9529	14410	5149	9314	13990	9611	15940	13330	2811	6893	4073	1064	155	226
Downstream	2 01 09-08-1999 14:34:15 01:00	9318	14370	4903	9354	14090	9587	16040	12750	2842	6744	4165	984	149	224
Downstream	2 01 09-08-1999 14:36:45 01:00	9267	14150	5038	9000	13800	9804	16120	12180	2684	6454	3754	933	141	200
Downstream	2 01 09-08-1999 14:39:15 01:00	8968	13990	4902	8920	13740	9493	15930	11910	2579	6297	3762	958	110	173
Downstream	2 01 09-08-1999 14:41:45 01:00	9263	14680	5053	9444	14080	9755	16330	12570	2735	6555	3929	912	144	190
Downstream	2 01 09-08-1999 14:44:15 01:00	9513	14670	5240	9306	14180	10070	16600	12540	2757	6625	3951	925	149	194
D. Bckgrnd	2 01 09-08-1999 14:54:15 01:00	1	1	0	0	0	0	0	0	0	0	0	0	0	0
Meas. Penetration		1.00	1.00	1.01	1.00	1.00	0.99	0.99	1.00	0.99	0.99	0.99	0.94	0.88	0.80
P100 correction values		1.00	1.00	1.00	1.00	1.00	1.00	1.00	1.00	1.00	1.00	1.00	1.00	1.00	1.00
Corrected Penetration		1.00	1.00	1.01	1.00	1.00	0.99	0.99	1.00	0.99	0.99	0.99	0.94	0.88	0.80
Corrected Efficiency (%)		0	0	-1	0	0	1	1	0	1	1	1	6	12	20
Data Acceptance Criteria:															
Total Challenge Counts for Each Channel:	94589	145000	50781	94315	142900	98974	164680	128790	28469	68057	40969	10725	1649	2624	1392
Data Quality Objective:	> 500	> 500	> 500	> 500	> 500	> 500	> 500	> 500	> 500	> 500	> 500	> 500	> 500	> 500	> 500
Does this meet DQO:	Yes	Yes	Yes	Yes	Yes	Yes	Yes	Yes	Yes	Yes	Yes	Yes	Yes	Yes	Yes
Standard Deviation of Penetration for Each Channel :	0.06	0.05	0.05	0.06	0.06	0.05	0.05	0.08	0.07	0.07	0.08	0.10	0.12	0.11	0.15
Data Quality Objective:	<0.10	<0.10	<0.10	<0.10	<0.10	<0.10	<0.10	<0.10	<0.10	<0.10	<0.30	<0.30	<0.30	<0.30	<0.30
Does this meet DQO:	Yes	Yes	Yes	Yes	Yes	Yes	Yes	Yes	Yes	Yes	Yes	Yes	Yes	Yes	Yes
Maximum observed particle concentration (#/cc):	16.0														
Data Quality Objective: max. allowable conc. (#/cc):	< 23														
Does this meet the DQO:	Yes, (applies to all channels)														

US EPA ARCHIVE DOCUMENT

Purolator DMK804404 and PB2424

Test No. 09089909  
 Arrestor  
 Liquid-Phase

Particle Counts per Indicated OPC Channel (1-Minute Samples @ 7.1 L/min)

OPC Channel Number	1	2	3	4	5	6	7	8	9	10	11	12	13	14	15
Min. Diam. (um)	0.28	0.37	0.47	0.52	0.66	0.94	1.22	1.51	1.88	2.07	2.83	3.77	4.71	5.18	6.60
Max. Diam. (um)	0.37	0.47	0.52	0.66	0.94	1.22	1.51	1.88	2.07	2.83	3.77	4.71	5.18	6.60	9.43
Geo. Mean Diam (um)	0.32	0.42	0.49	0.58	0.78	1.07	1.36	1.68	1.97	2.42	3.26	4.21	4.94	5.85	7.89

ENTER DATA BELOW

U. Bckgrnd	1 01 09-08-1999 16:51:46 01:00	1	1	0	0	0	0	0	0	0	0	0	0	0	0	
Upstream	1 01 09-08-1999 17:03:57 01:00	10100	15930	5621	10260	15470	10800	18280	13520	2968	6955	4172	1057	146	224	132
Upstream	1 01 09-08-1999 17:06:27 01:00	9834	15650	5611	9837	15460	10750	17950	13630	2946	6959	4219	1068	175	238	119
Upstream	1 01 09-08-1999 17:08:57 01:00	9568	14970	5185	9696	14790	10280	17270	12950	2826	6720	4033	1014	143	210	105
Upstream	1 01 09-08-1999 17:11:27 01:00	9980	15410	5558	10020	15220	10810	18010	13700	3109	6794	4055	1050	155	268	150
Upstream	1 01 09-08-1999 17:13:57 01:00	9283	14380	5227	9275	14270	9931	16680	12270	2617	6473	3822	990	143	234	135
Upstream	1 01 09-08-1999 17:16:27 01:00	9280	14390	5217	9141	14220	9723	16540	12550	2797	6394	3914	1004	162	228	113
Upstream	1 01 09-08-1999 17:18:57 01:00	7884	12360	4425	8225	12380	8280	14320	11570	2449	5786	3567	1030	135	207	126
Upstream	1 01 09-08-1999 17:21:27 01:00	8951	14000	4880	9179	13990	9440	16210	13240	2849	6539	4186	1137	167	275	128
Upstream	1 01 09-08-1999 17:23:57 01:00	9199	14360	5243	9339	14400	9596	16550	13510	2724	6646	4231	1131	149	257	133
Upstream	1 01 09-08-1999 17:26:27 01:00	9733	14870	5227	10070	15020	10270	17210	14470	2980	7115	4427	1143	178	305	149
U. Bckgrnd	1 01 09-08-1999 17:33:57 01:00	0	0	0	0	0	0	0	1	0	0	0	0	0	0	

ENTER DATA BELOW

D. Bckgrnd	2 01 09-08-1999 16:53:01 01:00	0	1	0	1	1	3	1	0	0	0	0	0	0	0	
Downstream	2 01 09-08-1999 17:05:12 01:00	6782	10600	3703	6553	9375	6107	9087	5262	867	1424	365	19	2	0	1
Downstream	2 01 09-08-1999 17:07:42 01:00	6894	10670	3790	6900	9796	6372	9323	5470	878	1484	359	24	6	1	0
Downstream	2 01 09-08-1999 17:10:12 01:00	6647	10490	3672	6663	9440	6051	8980	5047	846	1496	359	29	0	1	0
Downstream	2 01 09-08-1999 17:12:42 01:00	6795	10080	3572	6503	9428	5845	8723	5037	828	1499	398	18	1	0	0
Downstream	2 01 09-08-1999 17:15:12 01:00	6349	9861	3449	6222	8733	5715	8729	4906	820	1349	335	26	2	2	1
Downstream	2 01 09-08-1999 17:17:42 01:00	6229	9665	3236	6005	8547	5435	8183	4902	736	1399	363	19	0	0	0
Downstream	2 01 09-08-1999 17:20:12 01:00	6042	9220	3208	5968	8678	5488	8188	5153	825	1410	452	26	1	0	0
Downstream	2 01 09-08-1999 17:22:42 01:00	6213	9304	3313	6080	8826	5601	8270	5346	865	1473	393	34	0	0	0
Downstream	2 01 09-08-1999 17:25:12 01:00	6721	10240	3437	6653	9460	6023	9099	5896	887	1644	478	41	5	2	0
Downstream	2 01 09-08-1999 17:27:42 01:00	6900	10340	3610	6839	9863	6167	9240	5988	912	1658	438	43	2	0	0
D. Bckgrnd	2 01 09-08-1999 17:35:12 01:00	1	0	0	0	1	0	0	0	0	0	0	0	0	0	

Meas. Penetration	0.70	0.69	0.67	0.68	0.63	0.59	0.52	0.40	0.30	0.22	0.10	0.03	0.01	0.00	0.00
P100 correction values	1.00	1.00	1.01	1.00	1.00	0.99	0.99	1.00	0.99	0.99	0.99	0.94	0.88	0.80	0.66
Corrected Penetration	0.70	0.69	0.67	0.68	0.64	0.59	0.52	0.40	0.30	0.23	0.10	0.03	0.01	0.00	0.00
Corrected Efficiency (%)	30	31	33	32	36	41	48	60	70	77	90	97	99	100	100

Data Acceptance Criteria:

Total Challenge Counts for Each Channel:	93812	146320	52194	95042	145220	99880	169020	131410	28265	66381	40626	10624	1553	2446	1290
Data Quality Objective:	> 500	> 500	> 500	> 500	> 500	> 500	> 500	> 500	> 500	> 500	> 500	> 500	> 500	> 500	> 500
Does this meet DQO:	Yes	Yes	Yes	Yes	Yes	Yes	Yes	Yes	Yes	Yes	Yes	Yes	Yes	Yes	Yes

Standard Deviation of Penetration for Each Channel :	0.06	0.06	0.06	0.06	0.05	0.06	0.04	0.04	0.03	0.02	0.01	0.01	0.01	0.00	0.00
Data Quality Objective:	<0.10	<0.10	<0.10	<0.10	<0.10	<0.10	<0.10	<0.10	<0.10	<0.10	<0.30	<0.30	<0.30	<0.30	<0.30
Does this meet DQO:	Yes	Yes	Yes	Yes	Yes	Yes	Yes	Yes	Yes	Yes	Yes	Yes	Yes	Yes	Yes

Maximum observed particle concentration (#/cc): 16.3  
 Data Quality Objective: max. allowable conc. (#/cc): < 23  
 Does this meet the DQO: Yes, (applies to all channels)

US EPA ARCHIVE DOCUMENT

Purolator DMK804404 and PB2424

Test No. 09099902

No Filter

Liquid-Phase

Particle Counts per Indicated OPC Channel (1-Minute Samples @ 7.1 L/min)

OPC Channel Number	1	2	3	4	5	6	7	8	9	10	11	12	13	14	15
Min. Diam. (um)	0.28	0.37	0.47	0.52	0.66	0.94	1.22	1.51	1.88	2.07	2.83	3.77	4.71	5.18	6.60
Max. Diam. (um)	0.37	0.47	0.52	0.66	0.94	1.22	1.51	1.88	2.07	2.83	3.77	4.71	5.18	6.60	9.43
Geo. Mean Diam (um)	0.32	0.42	0.49	0.58	0.78	1.07	1.36	1.68	1.97	2.42	3.26	4.21	4.94	5.85	7.89

ENTER DATA BELOW

U. Bckgrnd	1 01 09-09-1999 07:19:12 01:00	0	0	0	0	0	0	0	0	0	0	0	0	0	0	
Upstream	1 01 09-09-1999 07:28:12 01:00	9469	14890	5335	9640	14730	10390	17780	13330	2748	6467	4300	1221	166	286	147
Upstream	1 01 09-09-1999 07:30:42 01:00	9703	15080	5345	9597	14750	10550	18150	13310	2741	6735	4216	1231	197	279	149
Upstream	1 01 09-09-1999 07:33:12 01:00	9916	15440	5461	9938	15150	10820	18230	13680	2752	6803	4374	1184	192	294	164
Upstream	1 01 09-09-1999 07:35:42 01:00	9961	16000	5551	10140	15660	10890	18430	13810	2867	6911	4333	1224	200	325	160
Upstream	1 01 09-09-1999 07:38:12 01:00	10160	15710	5624	10280	15300	10980	18620	14260	2906	7014	4594	1316	220	306	150
Upstream	1 01 09-09-1999 07:40:42 01:00	10000	15620	5552	10110	15420	10910	18340	13840	2804	6803	4246	1218	185	302	168
Upstream	1 01 09-09-1999 07:43:12 01:00	9708	15400	5363	9709	14860	10580	18030	13670	2702	6689	4401	1209	189	288	179
Upstream	1 01 09-09-1999 07:45:42 01:00	9657	15300	5448	9883	15020	10710	17920	13180	2626	6688	4285	1205	188	282	163
Upstream	1 01 09-09-1999 07:48:12 01:00	9403	14640	5188	9550	14400	10330	17220	12750	2673	6378	4215	1172	174	300	156
Upstream	1 01 09-09-1999 07:50:42 01:00	9568	15140	5437	9738	14690	10640	17590	13150	2615	6684	4173	1152	177	308	142
U. Bckgrnd	1 01 09-09-1999 07:58:12 01:00	0	0	0	0	0	0	0	0	0	0	0	0	0	0	

ENTER DATA BELOW

D. Bckgrnd	2 01 09-09-1999 07:20:27 01:00	1	0	0	0	0	0	0	0	0	0	0	0	0	0	
Downstream	2 01 09-09-1999 07:29:27 01:00	9784	15330	5521	10000	15190	10700	18240	13580	2841	6627	4291	1204	209	287	144
Downstream	2 01 09-09-1999 07:31:57 01:00	9649	15470	5354	9869	14890	10600	18140	13490	2866	6587	4348	1140	202	275	152
Downstream	2 01 09-09-1999 07:34:27 01:00	9786	15350	5538	10100	15500	10770	18580	14210	2837	6970	4361	1214	205	301	175
Downstream	2 01 09-09-1999 07:36:57 01:00	10230	15910	5693	10040	15530	10940	18470	13940	2771	6967	4490	1291	196	308	158
Downstream	2 01 09-09-1999 07:39:27 01:00	10210	15970	5711	10370	15480	11130	18950	13910	2889	6920	4381	1243	216	300	169
Downstream	2 01 09-09-1999 07:41:57 01:00	10000	15550	5543	9935	15250	11110	18360	13440	2888	6839	4310	1213	188	313	131
Downstream	2 01 09-09-1999 07:44:27 01:00	9718	14870	5335	9836	14720	10360	17630	13780	2801	6751	4401	1239	182	300	146
Downstream	2 01 09-09-1999 07:46:57 01:00	9554	15050	5166	9495	14760	10430	17580	13230	2826	6483	4215	1168	170	279	158
Downstream	2 01 09-09-1999 07:49:27 01:00	9736	15000	5436	9609	14750	10440	17750	13020	2743	6568	4241	1182	189	316	142
Downstream	2 01 09-09-1999 07:51:57 01:00	9786	15690	5763	10110	15230	10910	18520	14000	2758	6750	4287	1214	184	267	168
D. Bckgrnd	2 01 09-09-1999 07:59:27 01:00	0	0	0	0	0	0	0	0	0	0	0	0	0	0	

Meas. Penetration	1.01	1.01	1.01	1.01	1.01	1.01	1.01	1.01	1.01	1.03	1.00	1.00	1.00	1.03	0.99	0.98
P100 correction values	1.00	1.00	1.00	1.00	1.00	1.00	1.00	1.00	1.00	1.00	1.00	1.00	1.00	1.00	1.00	1.00
Corrected Penetration	1.01	1.01	1.01	1.01	1.01	1.01	1.01	1.01	1.01	1.03	1.00	1.00	1.00	1.03	0.99	0.98
Corrected Efficiency (%)	-1	-1	-1	-1	-1	-1	-1	-1	-1	-3	0	0	0	-3	1	2

Data Acceptance Criteria:

Total Challenge Counts for Each Channel:	97545	153220	54304	98585	149980	106800	180310	134980	27434	67172	43137	12132	1888	2970	1578
Data Quality Objective:	> 500	> 500	> 500	> 500	> 500	> 500	> 500	> 500	> 500	> 500	> 500	> 500	> 500	> 500	> 500
Does this meet DQO:	Yes	Yes	Yes	Yes	Yes	Yes	Yes	Yes	Yes	Yes	Yes	Yes	Yes	Yes	Yes

Standard Deviation of Penetration for Each Channel :	0.03	0.04	0.04	0.04	0.03	0.03	0.03	0.04	0.04	0.04	0.03	0.05	0.11	0.07	0.11
Data Quality Objective:	<0.10	<0.10	<0.10	<0.10	<0.10	<0.10	<0.10	<0.10	<0.10	<0.10	<0.30	<0.30	<0.30	<0.30	<0.30
Does this meet DQO:	Yes	Yes	Yes	Yes	Yes	Yes	Yes	Yes	Yes	Yes	Yes	Yes	Yes	Yes	Yes

Maximum observed particle concentration (#/cc):	16.7
Data Quality Objective: max. allowable conc. (#/cc):	< 23
Does this meet the DQO:	Yes, (applies to all channels)

US EPA ARCHIVE DOCUMENT

Test No. 09099903

Arrestor  
Liquid-Phase

Particle Counts per Indicated OPC Channel (1-Minute Samples @ 7.1 L/min)

OPC Channel Number	1	2	3	4	5	6	7	8	9	10	11	12	13	14	15
Min. Diam. (um)	0.28	0.37	0.47	0.52	0.66	0.94	1.22	1.51	1.88	2.07	2.83	3.77	4.71	5.18	6.60
Max. Diam. (um)	0.37	0.47	0.52	0.66	0.94	1.22	1.51	1.88	2.07	2.83	3.77	4.71	5.18	6.60	9.43
Geo. Mean Diam (um)	0.32	0.42	0.49	0.58	0.78	1.07	1.36	1.68	1.97	2.42	3.26	4.21	4.94	5.85	7.89

ENTER DATA BELOW

U. Bckgrnd	1	01	09-09-1999	08:18:12	01:00	2	4	0	0	0	0	0	0	0	0	0				
Upstream	1	01	09-09-1999	08:28:29	01:00	9221	14440	5092	9660	14560	9822	16910	14140	2830	6576	4392	1290	203	323	167
Upstream	1	01	09-09-1999	08:30:59	01:00	9435	14560	5268	9667	14770	10020	17220	14450	2904	6824	4630	1281	215	321	203
Upstream	1	01	09-09-1999	08:33:29	01:00	9239	14010	4995	9362	14550	9934	16950	14280	2863	6660	4433	1369	221	303	179
Upstream	1	01	09-09-1999	08:35:59	01:00	9183	14220	5069	9662	14610	9954	16770	14470	2848	6833	4592	1374	237	334	193
Upstream	1	01	09-09-1999	08:38:29	01:00	8819	13650	4786	9371	14210	9253	16110	14670	2934	6795	4731	1348	195	320	180
Upstream	1	01	09-09-1999	08:40:59	01:00	9032	13980	4860	9403	14160	9630	16310	14120	2770	6578	4501	1278	189	313	178
Upstream	1	01	09-09-1999	08:43:29	01:00	7798	12120	4309	7829	11830	8364	14110	10890	2206	5313	3381	994	145	227	118
Upstream	1	01	09-09-1999	08:45:59	01:00	9200	14600	5082	9386	14370	10060	17170	13080	2654	6422	4132	1167	183	309	140
Upstream	1	01	09-09-1999	08:48:29	01:00	9356	14590	5265	9541	14490	10090	17250	13350	2707	6576	4221	1218	205	292	141
Upstream	1	01	09-09-1999	08:50:59	01:00	9318	14640	5188	9467	14550	10570	17290	13500	2834	6757	4208	1211	180	291	180
U. Bckgrnd	1	01	09-09-1999	09:00:59	01:00	0	0	0	0	0	0	0	0	0	0	0	0	0	0	0

ENTER DATA BELOW

D. Bckgrnd	2	01	09-09-1999	08:19:27	01:00	2	1	0	0	0	0	0	0	0	0	0	0	0	0	0
Downstream	2	01	09-09-1999	08:29:44	01:00	6698	10010	3474	6627	9626	6030	9422	6417	909	1701	520	42	6	2	0
Downstream	2	01	09-09-1999	08:32:14	01:00	6760	10040	3491	6755	9761	6131	9219	6643	1031	1743	555	50	7	1	1
Downstream	2	01	09-09-1999	08:34:44	01:00	6640	10010	3447	6549	9742	6029	9472	6296	964	1768	526	56	2	0	0
Downstream	2	01	09-09-1999	08:37:14	01:00	6823	10170	3658	6604	9721	6078	9358	6390	1016	1750	577	34	6	2	0
Downstream	2	01	09-09-1999	08:39:44	01:00	6345	9715	3471	6275	9380	5855	9160	6116	962	1667	507	43	5	3	1
Downstream	2	01	09-09-1999	08:42:14	01:00	6426	9960	3528	6669	9573	5912	9489	6450	920	1725	535	38	2	2	0
Downstream	2	01	09-09-1999	08:44:44	01:00	6641	10100	3623	6451	9371	6018	8998	5537	821	1506	440	39	4	4	2
Downstream	2	01	09-09-1999	08:47:14	01:00	6661	10100	3496	6373	9171	5936	9436	5552	873	1542	479	31	3	3	0
Downstream	2	01	09-09-1999	08:49:44	01:00	6941	10830	3682	6764	9672	6397	9980	6151	963	1708	489	34	1	1	1
Downstream	2	01	09-09-1999	08:52:14	01:00	6685	10130	3592	6683	9688	6158	9628	6639	1041	1771	590	43	3	7	1
D. Bckgrnd	2	01	09-09-1999	09:02:14	01:00	0	0	0	0	0	0	0	0	0	0	0	0	0	0	0

Meas. Penetration	0.74	0.72	0.71	0.70	0.67	0.62	0.57	0.45	0.34	0.26	0.12	0.03	0.02	0.01	0.00
P100 correction values	1.01	1.01	1.01	1.01	1.01	1.01	1.01	1.01	1.03	1.00	1.00	1.00	1.03	0.99	0.98
Corrected Penetration	0.73	0.71	0.70	0.70	0.67	0.62	0.56	0.45	0.34	0.26	0.12	0.03	0.02	0.01	0.00
Corrected Efficiency (%)	27	29	30	30	33	38	44	55	66	74	88	97	98	99	100

Data Acceptance Criteria:

Total Challenge Counts for Each Channel:	90601	140810	49914	93348	142100	97697	166090	136950	27550	65334	43221	12530	1973	3033	1679
Data Quality Objective:	> 500	> 500	> 500	> 500	> 500	> 500	> 500	> 500	> 500	> 500	> 500	> 500	> 500	> 500	> 500
Does this meet DQO:	Yes	Yes	Yes	Yes	Yes	Yes	Yes	Yes	Yes	Yes	Yes	Yes	Yes	Yes	Yes

Standard Deviation of Penetration for Each Channel :	0.04	0.04	0.04	0.04	0.04	0.04	0.04	0.05	0.04	0.02	0.02	0.01	0.01	0.01	0.00
Data Quality Objective:	<0.10	<0.10	<0.10	<0.10	<0.10	<0.10	<0.10	<0.10	<0.10	<0.10	<0.30	<0.30	<0.30	<0.30	<0.30
Does this meet DQO:	Yes	Yes	Yes	Yes	Yes	Yes	Yes	Yes	Yes	Yes	Yes	Yes	Yes	Yes	Yes

Maximum observed particle concentration (#/cc): 15.8  
 Data Quality Objective: max. allowable conc. (#/cc): < 23  
 Does this meet the DQO: Yes, (applies to all channels)

Test No. 09099904

No Filter

Liquid-Phase

Particle Counts per Indicated OPC Channel (1-Minute Samples @ 7.1 L/min)

OPC Channel Number	1	2	3	4	5	6	7	8	9	10	11	12	13	14	15
Min. Diam. (um)	0.28	0.37	0.47	0.52	0.66	0.94	1.22	1.51	1.88	2.07	2.83	3.77	4.71	5.18	6.60
Max. Diam. (um)	0.37	0.47	0.52	0.66	0.94	1.22	1.51	1.88	2.07	2.83	3.77	4.71	5.18	6.60	9.43
Geo. Mean Diam (um)	0.32	0.42	0.49	0.58	0.78	1.07	1.36	1.68	1.97	2.42	3.26	4.21	4.94	5.85	7.89

ENTER DATA BELOW

U. Bckgrnd	1 01 09-09-1999 09:23:56 01:00	2	2	0	0	1	0	0	0	0	0	0	0	0	0	
Upstream	1 01 09-09-1999 09:36:20 01:00	9968	15880	5541	10130	15390	11060	18350	14000	2821	6899	4444	1228	193	281	157
Upstream	1 01 09-09-1999 09:38:50 01:00	10080	15830	5613	10430	15580	11080	18720	13900	2953	7168	4353	1252	206	312	159
Upstream	1 01 09-09-1999 09:41:20 01:00	9888	15980	5646	10320	15400	10770	18610	13570	2888	6902	4371	1229	205	313	151
Upstream	1 01 09-09-1999 09:43:50 01:00	9805	15930	5512	10090	15330	10890	18540	13640	2825	6835	4478	1250	188	343	157
Upstream	1 01 09-09-1999 09:46:20 01:00	9487	15150	5390	9743	14910	10510	17730	13210	2781	6628	4234	1175	162	276	150
Upstream	1 01 09-09-1999 09:48:50 01:00	9656	14960	5276	9825	14740	10400	17700	13080	2726	6677	4313	1198	201	271	173
Upstream	1 01 09-09-1999 09:51:20 01:00	9470	14900	5243	9695	14770	10460	17710	12900	2791	6611	4182	1200	183	293	171
Upstream	1 01 09-09-1999 09:53:50 01:00	10050	15760	5718	9926	15710	11140	18490	13730	2857	6999	4371	1369	183	330	164
Upstream	1 01 09-09-1999 09:56:20 01:00	9967	15570	5423	10050	15410	10910	18390	13800	2841	6880	4395	1273	198	311	169
Upstream	1 01 09-09-1999 09:58:50 01:00	10460	16010	5588	10020	15570	11050	18350	13840	2826	6996	4396	1343	205	280	171
U. Bckgrnd	1 01 09-09-1999 10:07:19 01:00	0	0	0	0	0	0	0	0	0	0	0	0	0	0	0

ENTER DATA BELOW

D. Bckgrnd	2 01 09-09-1999 09:25:11 01:00	2	0	0	0	0	0	0	0	0	0	0	0	0	0	0
Downstream	2 01 09-09-1999 09:37:35 01:00	10100	16120	5725	10270	15610	11370	18880	13800	2779	6832	4298	1233	184	272	164
Downstream	2 01 09-09-1999 09:40:05 01:00	10230	16380	5675	10550	15960	11490	19410	14360	3011	7126	4649	1237	216	299	188
Downstream	2 01 09-09-1999 09:42:35 01:00	10300	16070	5735	10290	15890	11470	19150	13810	2860	6896	4454	1226	191	279	141
Downstream	2 01 09-09-1999 09:45:05 01:00	9858	15620	5496	9889	15240	10790	18390	13670	2843	6997	4372	1216	191	299	171
Downstream	2 01 09-09-1999 09:47:35 01:00	10010	15590	5507	9851	15320	10910	18460	13350	2822	6723	4295	1196	181	269	158
Downstream	2 01 09-09-1999 09:50:05 01:00	9570	15030	5317	9429	14980	10560	17920	13270	2790	6598	4224	1201	166	297	149
Downstream	2 01 09-09-1999 09:52:35 01:00	9789	15230	5471	9731	14790	10710	18040	13280	2734	6722	4125	1179	168	285	151
Downstream	2 01 09-09-1999 09:55:05 01:00	10090	16110	5809	10120	15520	11340	19070	13560	2874	7064	4326	1185	207	257	146
Downstream	2 01 09-09-1999 09:57:35 01:00	10120	15920	5690	10140	15610	11230	19030	13490	2837	7004	4351	1166	199	279	152
Downstream	2 01 09-09-1999 10:00:05 01:00	10240	15670	5623	9849	15380	11060	18750	13330	2798	7004	4279	1150	165	291	154
D. Bckgrnd	2 01 09-09-1999 10:08:34 01:00	0	0	0	0	0	0	0	0	0	0	0	0	0	0	0

Meas. Penetration	1.01	1.01	1.02	1.00	1.01	1.02	1.02	1.00	1.00	1.01	1.00	0.96	0.97	0.94	0.97
P100 correction values	1.00	1.00	1.00	1.00	1.00	1.00	1.00	1.00	1.00	1.00	1.00	1.00	1.00	1.00	1.00
Corrected Penetration	1.01	1.01	1.02	1.00	1.01	1.02	1.02	1.00	1.00	1.01	1.00	0.96	0.97	0.94	0.97
Corrected Efficiency (%)	-1	-1	-2	0	-1	-2	-2	0	0	-1	0	4	3	6	3

Data Acceptance Criteria:

Total Challenge Counts for Each Channel:	98831	155970	54950	100229	152810	108270	182590	135670	28309	68595	43537	12517	1924	3010	1622
Data Quality Objective:	> 500	> 500	> 500	> 500	> 500	> 500	> 500	> 500	> 500	> 500	> 500	> 500	> 500	> 500	> 500
Does this meet DQO:	Yes	Yes	Yes	Yes	Yes	Yes	Yes	Yes	Yes	Yes	Yes	Yes	Yes	Yes	Yes

Standard Deviation of Penetration for Each Channel :	0.04	0.04	0.04	0.04	0.03	0.04	0.03	0.04	0.03	0.04	0.04	0.05	0.11	0.09	0.10
Data Quality Objective:	<0.10	<0.10	<0.10	<0.10	<0.10	<0.10	<0.10	<0.10	<0.10	<0.10	<0.30	<0.30	<0.30	<0.30	<0.30
Does this meet DQO:	Yes	Yes	Yes	Yes	Yes	Yes	Yes	Yes	Yes	Yes	Yes	Yes	Yes	Yes	Yes

Maximum observed particle concentration (#/cc):	17.1
Data Quality Objective: max. allowable conc. (#/cc):	< 23
Does this meet the DQO:	Yes, (applies to all channels)

Test No. 09099905

Arrestor  
Liquid-Phase

Particle Counts per Indicated OPC Channel (1-Minute Samples @ 7.1 L/min)

OPC Channel Number	1	2	3	4	5	6	7	8	9	10	11	12	13	14	15
Min. Diam. (um)	0.28	0.37	0.47	0.52	0.66	0.94	1.22	1.51	1.88	2.07	2.83	3.77	4.71	5.18	6.60
Max. Diam. (um)	0.37	0.47	0.52	0.66	0.94	1.22	1.51	1.88	2.07	2.83	3.77	4.71	5.18	6.60	9.43
Geo. Mean Diam (um)	0.32	0.42	0.49	0.58	0.78	1.07	1.36	1.68	1.97	2.42	3.26	4.21	4.94	5.85	7.89

ENTER DATA BELOW

U. Bckgrnd	1	01	09-09-1999	10:25:48	01:00	0	0	0	0	0	0	0	0	0	0	0				
Upstream	1	01	09-09-1999	10:33:39	01:00	9325	14860	5173	9473	14490	10230	17340	13070	2707	6409	4210	1205	202	299	167
Upstream	1	01	09-09-1999	10:36:09	01:00	9740	15320	5448	9877	15140	10860	18220	13720	2897	6781	4408	1209	182	280	167
Upstream	1	01	09-09-1999	10:38:39	01:00	9822	15370	5507	9868	15150	10720	18060	13860	2744	6896	4473	1213	177	302	175
Upstream	1	01	09-09-1999	10:41:09	01:00	9546	15020	5379	9698	14650	10370	17490	13250	2661	6655	4285	1156	173	305	158
Upstream	1	01	09-09-1999	10:43:39	01:00	9682	15240	5400	9929	15130	10800	18000	13750	2820	6774	4418	1230	192	281	175
Upstream	1	01	09-09-1999	10:46:09	01:00	9630	15100	5330	9864	14930	10490	17690	13650	2915	6788	4455	1246	218	290	188
Upstream	1	01	09-09-1999	10:48:39	01:00	8771	13410	4771	8978	13900	9465	15840	13920	2813	6452	4350	1256	179	329	165
Upstream	1	01	09-09-1999	10:51:09	01:00	9202	14410	5152	9830	14980	10180	17180	14680	3069	7126	4810	1340	217	381	199
Upstream	1	01	09-09-1999	10:53:39	01:00	9429	14700	5232	9835	14920	10140	17280	14850	2927	7060	4652	1338	219	329	216
Upstream	1	01	09-09-1999	10:56:09	01:00	9573	14970	5227	10120	15260	10290	17510	15290	3098	7243	4915	1506	223	322	195
U. Bckgrnd	1	01	09-09-1999	11:07:45	01:00	0	0	0	0	0	0	0	0	0	0	0	0	0	0	0

ENTER DATA BELOW

D. Bckgrnd	2	01	09-09-1999	10:27:03	01:00	0	0	0	0	0	0	0	0	0	0	0	0	0	0	0	0
Downstream	2	01	09-09-1999	10:34:54	01:00	7035	10900	3867	6947	9942	6582	9861	5985	938	1709	497	43	1	1	0	0
Downstream	2	01	09-09-1999	10:37:24	01:00	7260	11130	3843	7103	10050	6599	10090	6206	908	1732	550	28	4	3	0	0
Downstream	2	01	09-09-1999	10:39:54	01:00	7032	10560	3663	6694	9764	6326	9565	5866	992	1651	492	41	1	1	0	0
Downstream	2	01	09-09-1999	10:42:24	01:00	7238	10900	3824	6823	9799	6576	9756	5911	908	1852	488	41	1	4	0	0
Downstream	2	01	09-09-1999	10:44:54	01:00	7029	10830	3750	6884	10050	6451	9864	6085	958	1746	521	44	2	1	0	0
Downstream	2	01	09-09-1999	10:47:24	01:00	6958	10550	3821	6865	9880	6564	10070	6169	995	1784	552	35	2	0	1	0
Downstream	2	01	09-09-1999	10:49:54	01:00	6842	10390	3627	6817	10040	6264	9579	7015	1103	1982	598	59	6	3	0	0
Downstream	2	01	09-09-1999	10:52:24	01:00	6772	10370	3577	6805	10040	6238	9656	6841	1031	1929	582	53	7	3	0	0
Downstream	2	01	09-09-1999	10:54:54	01:00	6875	10340	3704	7072	10110	6319	9906	6926	1074	1985	651	42	4	3	1	0
Downstream	2	01	09-09-1999	10:57:24	01:00	6827	10350	3732	6807	10040	6392	9992	6867	1098	2019	630	63	1	3	0	0
D. Bckgrnd	2	01	09-09-1999	11:09:00	01:00	0	0	0	0	0	0	0	0	0	0	0	0	0	0	0	0

Meas. Penetration	0.74	0.72	0.71	0.71	0.67	0.62	0.56	0.46	0.35	0.27	0.12	0.04	0.01	0.01	0.00
P100 correction values	1.01	1.01	1.02	1.00	1.01	1.02	1.02	1.00	1.00	1.01	1.00	0.96	0.97	0.94	0.97
Corrected Penetration	0.73	0.71	0.70	0.71	0.66	0.61	0.55	0.46	0.35	0.27	0.12	0.04	0.02	0.01	0.00
Corrected Efficiency (%)	27	29	30	29	34	39	45	54	65	73	88	96	98	99	100

Data Acceptance Criteria:

Total Challenge Counts for Each Channel:	94720	148400	52619	97472	148550	103545	174610	140040	28651	68184	44976	12699	1982	3118	1805
Data Quality Objective:	> 500	> 500	> 500	> 500	> 500	> 500	> 500	> 500	> 500	> 500	> 500	> 500	> 500	> 500	> 500
Does this meet DQO:	Yes	Yes	Yes	Yes	Yes	Yes	Yes	Yes	Yes	Yes	Yes	Yes	Yes	Yes	Yes

Standard Deviation of Penetration for Each Channel :	0.03	0.03	0.03	0.03	0.02	0.03	0.02	0.04	0.03	0.02	0.01	0.01	0.01	0.00	0.00
Data Quality Objective:	<0.10	<0.10	<0.10	<0.10	<0.10	<0.10	<0.10	<0.10	<0.10	<0.10	<0.30	<0.30	<0.30	<0.30	<0.30
Does this meet DQO:	Yes	Yes	Yes	Yes	Yes	Yes	Yes	Yes	Yes	Yes	Yes	Yes	Yes	Yes	Yes

Maximum observed particle concentration (#/cc):	16.4
Data Quality Objective: max. allowable conc. (#/cc):	< 23
Does this meet the DQO:	Yes, (applies to all channels)