

US EPA ARCHIVE DOCUMENT

Environmental Technology Verification Program Advanced Monitoring Systems Pilot

Test/QA Plan for
Verification of On-Line
Turbidimeters

US EPA ARCHIVE DOCUMENT

ET ✓ ET ✓ ET ✓

TEST/QA PLAN

FOR

**VERIFICATION OF
ON-LINE TURBIDIMETERS**

June 3, 1999

Prepared by

**Battelle
505 King Avenue
Columbus, OH 43201-2693**

APPROVALS

Endress + Hauser Conducta

Date

Monitek Technologies, Inc.

Date

Sigrist

Date

TABLE OF CONTENTS

1.	Introduction	1
1.1.	Test Description	1
1.2.	Test Objective	1
1.3.	Applicability	1
2.	Technology Description	2
3.	Verification Approach	3
3.1.	Scope of Test	3
3.2.	Test Considerations and Approach	4
3.3.	Organization and Responsibilities	5
3.3.1	Battelle	7
3.3.2	Vendors	10
3.3.3	EPA	10
3.3.4	Test Facilities	11
4.	Experimental Design	12
4.1.	General Description of Test Procedures	12
4.2.	Reference Methods	13
4.3.	Sample Introduction	13
4.4.	Off-line Test	15
4.5.	On-line Testing	15
5.	Test Procedures	16
5.1.	Off-line Test	17
5.1.1	Detection Limit	18
5.1.2	Linearity	19
5.1.3	Accuracy and Precision	20
5.1.4	Water Temperature	21
5.1.5	Flow Rate	21
5.1.6	Color	21
5.2.	On-Line Testing	23
5.2.1	Accuracy	24
5.2.2	Real World Variability	24
5.2.3	Drift	25
5.3.	Schedule	26
6.	Site Description	28
6.1.	General Site Description	28
6.2.	Test Water Source	28
6.3.	Site Operation	28

7.	Materials and Equipment	29
7.1.	Benchtop Reference Turbidimeters	29
7.2.	Formazin Solutions	29
7.3.	Recirculation System	30
7.4.	Temperature Sensor	32
7.5.	Flow Meter	32
7.6.	pH Meter	33
7.7.	Data Acquisition System	33
8.	Quality Assurance/Quality Control	33
8.1.	Calibration	33
8.1.1	Reference Turbidimeters	33
8.1.2	Temperature Sensors	34
8.1.3	Flow Meters	35
8.1.4	pH Meter	35
8.2.	Data Collection	35
8.3.	Assessments and Audits	36
8.3.1	Technical Systems Audit	36
8.3.2	Performance Evaluation Audit	37
8.3.3	Verification Test Data Audit	38
8.4.	Audit Reporting	38
8.5.	Corrective Action	39
9.	Data Analysis and Reporting	39
9.1.	Data Acquisition	39
9.2.	Summary of Verification Test	40
9.3.	Statistical Calculations	40
9.3.1	Detection Limit	40
9.3.2	Linearity	43
9.3.3	Accuracy	43
9.3.4	Precision	43
9.3.5	Water Temperature Effects	44
9.3.6	Flow Rate Sensitivity	44
9.3.7	Color Effects	45
9.3.8	Drift	45
9.4.	Data Review	45
9.5.	Reporting	46
10.	Health and Safety	46
10.1.	General	46
10.2.	Potential Hazards	47
10.2.1	Hydrazine Sulfate	47

10.2.2 Concentrated Acids 47

11. Definitions 48

12. References 50

APPENDIX A - EPA Method 180.1 A

APPENDIX B - Example Data Sheets B

LIST OF FIGURES

1. Organizational Chart for On-Line Turbidimeter Verification Test 6

2. Schematic Representation of Recirculation System 14

LIST OF TABLES

1. Summary of Parameters to be Evaluated in Off-Line Testing 16

2. Summary of Parameters to be Evaluated in On-Line Testing 17

3. Summary of Measurements for Off-Line Verification Tests 23

4. Summary of Measurements for On-Line Testing 26

5. Test Schedule 27

6. Standard Solution Dilution Summary 30

7. Quality Assurance Criteria for Calibration 36

8. Performance Audit Summary 38

9. Summary of Data Recording Process for the Verification Test 41

10. Sampling Summary 42

1. INTRODUCTION

1.1. Test Description

This test/QA plan provides detailed procedures for a verification test of on-line turbidimeters for use in water treatment facilities. The verification test will be conducted under the auspices of the U.S. Environmental Protection Agency (EPA) through the Environmental Technology Verification (ETV) program. The purpose of ETV is to provide objective and quality assured performance data on environmental technologies, so that users, developers, regulators, and consultants can make informed decisions about these technologies.

The verification test will be performed by Battelle, of Columbus, Ohio, which is managing the ETV Advanced Monitoring Systems (AMS) pilot through a cooperative agreement with EPA (CR 826215-01-1). The scope of the AMS pilot covers verification of monitoring methods for contaminants and natural species in air, water, and soil. In performing the verification test, Battelle will follow procedures specified in this test/QA plan, and will comply with the quality requirements in the “Quality Management Plan for the ETV Advanced Monitoring Systems Pilot” (QMP).¹

1.2. Test Objective

The goal of this verification test is to quantify the performance characteristics of commercially available turbidimeters for on-line use in water treatment facilities. This verification will involve comparison of these on-line turbidimeters with benchtop reference turbidimeters under a variety of realistic operational conditions.

1.3. Applicability

The technologies tested under this plan are commercial turbidimeters capable of real-time

monitoring of the low-level turbidity necessary to reliably assess compliance with current drinking water regulations. In such applications these turbidimeters can provide real-time continuous monitoring of water quality and allow early warning of potential non-compliance conditions, whereas grab sample analysis by standard methods is both time-consuming and non-continuous. Although not typically used for reporting purposes, these technologies are gaining wide acceptance throughout the industry, and as such, warrant performance verification.

2. TECHNOLOGY DESCRIPTION

The technologies to be verified under this test/QA plan rely upon 90° light scattering (i.e. nephelometry), or forward scattering, as a means of water quality characterization. These technologies are capable of continuous monitoring and can be designed either for use directly in-line by immersion in the sample stream, or alternatively, in a by-pass mode of operation. In the case of by-pass turbidimeters, the sample stream is drawn from a larger source stream and is directed through the nephelometer for subsequent analysis, whereas the immersion turbidimeters are designed for operation through direct submersion in the source water stream. Although the overall design requirements are significantly different, the basic components of these technologies are similar.

In general, these technologies contain at least the following components:

- Light source
- Optics
- Detector.

Typically the light sources for these technologies belong to one of two distinct groups. Historically, a filtered, broadband source has been used for turbidity measurement. This type of source consists of a tungsten lamp operated at a color temperature between 2200 - 3000 C. More recently, narrow

wavelength sources, including light emitting diodes (LEDs) and lasers, with intensity maxima in the IR have been introduced as an alternative light source for these measurements. The technologies to be tested under this test/QA plan employ one or more light sources which fit into these categories and can be configured in single or multiple beam arrangements.

Optics in these technologies are used for focusing of the incident source beam and collection of the scattered light. The detectors used are generally either photomultiplier tubes or photodiode assemblies and are chosen to match the spectral output of the light source with the peak detector response. The technologies generally provide a digital output which can be processed remotely to allow continuous, in-situ monitoring capabilities.

3. VERIFICATION APPROACH

3.1. Scope of Test

The overall objective of the verification test is to provide quantitative verification of the performance of on-line turbidimeters under realistic operational conditions. These technologies are commonly used for water quality monitoring in water treatment facilities and to help ensure compliance with drinking water regulations. For these applications, the turbidimeters must be accurate relative to the reference method used for reporting, and must have a detection limit at least below the typical regulatory limits. Additionally, since these technologies are used on-line, they should be both reliable and exhibit excellent stability properties to avoid frequent or unscheduled off-line maintenance. The verification test is designed to address and quantify each of these performance characteristics. Furthermore, since these technologies are to be used for monitoring of water treatment, their exposure to process perturbations is inevitable. Consequently, the verification test will simulate various upset conditions to assess the technology response under those conditions. Specifically, the performance characteristics to be verified include:

- **Detection limit** - determined from the instrumental response to low turbidity water under the conditions of testing.
- **Linearity** - determined from a multi-point calibration check in the range from 0-5 NTU.
- **Accuracy** - assessed relative to the benchtop reference turbidimeters.
- **Precision** - determined from multiple turbidity measurements of a sample solution.
- **Water temperature effects** - determined from the change in turbidimeter response to changes in sample temperature.
- **Flow rate sensitivity** - assessed from the change in instrumental response over a range of specified flow rates.
- **Color effects** - determined from the instrumental response to the addition of color to the sample.
- **Drift** - determined from the change in response to one or more standard solutions over the period of testing.

Additionally, characteristics such as ease of use, reliability, maintenance, and cost will be assessed and reported.

Some of the technologies to be verified in this test are submersible turbidimeters designed for use directly in the water stream. Consequently, those technologies are rated for use over a range of operational depths. It is beyond the scope of this test to verify the performance of these technologies at varying depths, and therefore, this aspect of performance will not be addressed in this test. Verification of these technologies will be performed at a depth recommended by the respective vendors.

3.2. Test Considerations and Approach

Since turbidity is a measurement of light scattering, a number of factors can influence the responses of these technologies to a given sample solution. Instrumental design including light source

selection and geometric differences may result in significant differences between the responses of these technologies and the reference measurements. Further differences may result from the variable nature of both the size and composition of particles typically found in water streams, relative to those in standard formazin solutions. These issues will be addressed in this verification test in two ways: 1) by using different instrumental designs for the reference turbidimeters, and 2) by evaluating a variety of different samples.

To avoid potential bias associated with a single method of comparison, the verification test will include two reference methods for data comparisons. The methods chosen as the means for establishing quantitative performance characteristics in this verification test are described in EPA Method 180.1, "Determination of Turbidity by Nephelometry",² and in ISO 7027, "Water Quality - Determination of Turbidity".⁴ These methods both detail a procedure for the measurement of turbidity using a benchtop nephelometric turbidimeter, but with differences in the type of light source and the wavelength used.

Additionally, to assess the response of these technologies to both prepared solutions and to real world water samples, verification will involve both off-line and on-line tests. The off-line test will include challenging the technologies with a series of prepared standards or other test solutions to verify performance under well controlled conditions. The on-line test will assess long-term performance under realistic operating conditions by monitoring a sample stream in a municipal treatment facility under typical normal operation.

3.3. Organization and Responsibilities

The verification test will be performed by Battelle with the participation of EPA and the vendors who will be having their turbidimeters verified. The test will occur with the cooperation of the City of Columbus Water Division at the Dublin Road Water Plant in Columbus, Ohio. The organizational chart in Figure 1 shows the individuals from Battelle, the vendor companies, and EPA who will have responsibilities in the verification test. The specific responsibilities of these

individuals are detailed below.

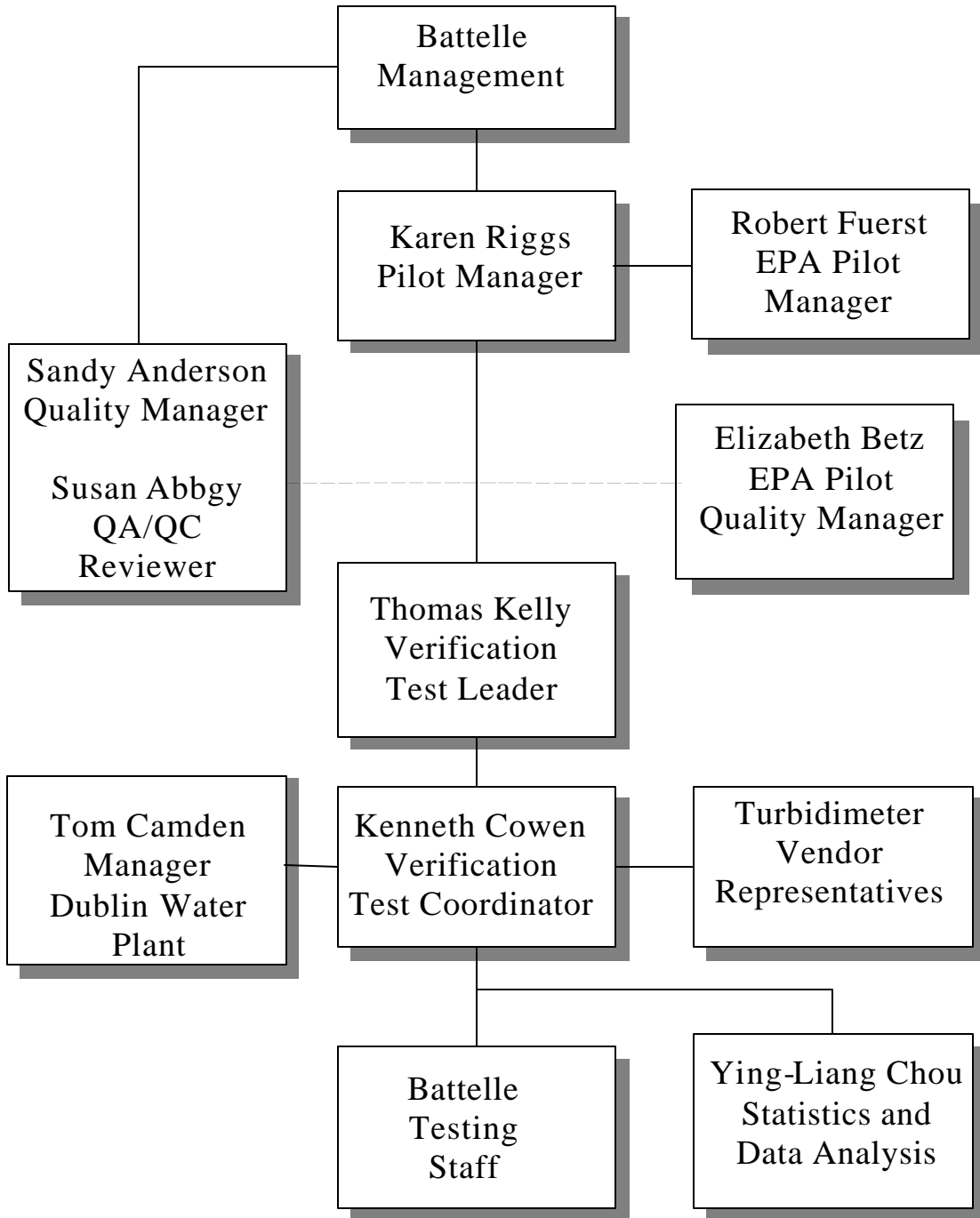

Figure 1. Organizational Chart for On-Line Turbidimeter Verification Test

3.3.1 Battelle

Dr. Kenneth A. Cowen is the Verification Test Coordinator for the testing of on-line turbidimeters through the AMS pilot. In this role, Dr. Cowen will have the overall responsibility for ensuring that the technical, scheduling, and cost goals established for the verification test are met. Dr. Cowen will:

- Prepare the draft test/QA plan, verification reports, and verification statements
- Revise the draft test/QA plan, verification reports, and verification statements in response to reviewers' comments
- Assemble a team of qualified technical staff to conduct the verification test
- Direct the team in performing the verification test in accordance with the test/QA plan
- Ensure that all quality procedures specified in the test/QA plan and in the QMP are followed
- Respond to any issues raised in assessment reports and audits, including instituting corrective action as necessary
- Serve as the primary point of contact for vendor representatives
- Establish a budget for the verification test and monitor staff effort to ensure that the budget is not exceeded
- Ensure that confidentiality of vendor information is maintained.

Dr. Thomas J. Kelly is the Verification Testing Leader for the AMS pilot. As such, Dr. Kelly will provide technical guidance and oversee the various stages of the verification test. He will:

- Support Dr. Cowen in preparing the test/QA plan and organizing the test
- Review the draft test/QA plan

- Review the draft verification reports and verification statements
- Ensure that vendor confidentiality is maintained.

Ms. Karen Riggs is Battelle's ETV pilot manager. As such, Ms. Riggs will:

- Review the draft test/QA plan
- Review the draft verification reports and verification statements
- Coordinate distribution of the final test/QA plan, verification reports, and verification statements
- Ensure that necessary Battelle resources, including staff and facilities, are committed to the verification test
- Ensure that vendor confidentiality is maintained
- Support Dr. Cowen in responding to any issues raised in assessment reports and audits
- Maintain communication with EPA's pilot and quality managers.

Mr. Jan Satola will conduct the testing of the turbidimeters during the verification test. The responsibilities of Mr. Satola include:

- Assist in the set-up of the manifold system
- Prepare standard formazin solutions for the test
- Calibrate and operate benchtop turbidimeters throughout the test duration
- Collect and analyze grab samples for the verification test as described in this test/QA plan
- Record and download data from the test
- Contact vendor if on-site maintenance is required.

Mr. Ying-Liang Chou will provide statistical and data analysis support for this verification test.

Specifically Mr. Chou will:

- Assist as needed in the conversion of verification data from electronic spreadsheet format to appropriate file format for statistical evaluation
- Support Dr. Cowen in performing statistical calculations specified in this test/QA plan on the verification data
- Review, as appropriate, results of statistical calculations and associated discussion for the verification reports
- Support Dr. Cowen in responding to any issues raised in assessment reports and audits related to statistics and data reduction.

Ms. Susan Abby will serve as the QA/QC reviewer for this verification test. As such Ms. Abby will:

- Review the draft test/QA plan
- Conduct a technical system audit once during the verification test
- Review performance evaluation audit results as specified in the test/QA plan
- Audit at least 10% of the verification data
- Prepare and distribute an assessment report for each audit
- Verify implementation of any necessary corrective action
- Issue a stop work order if self audits indicate that data quality is being compromised; notify Battelle Quality Manager if stop work order is issued
- Provide a summary of the QA/QC activities and results for the verification reports
- Review the draft verification reports and statements
- Have an overall responsibility for ensuring that the test/QA plan is followed.

Ms. Sandra M. Anderson is Battelle's Quality Manager for the AMS pilot. For this verification

test Ms. Anderson will:

- Support Ms. Abby in performing her QA/QC responsibilities
- Review Ms. Abby's assessment reports before distribution
- Ensure that Battelle management is informed if persistent quality problems are not corrected
- Interface with EPA's Pilot Quality Manager
- Have overall responsibility for ensuring that the QMP is followed.

3.3.2 Vendors

Vendor representatives will:

- Review the draft test/QA plan
- Approve the revised test/QA plan
- Provide off-the-shelf models of the turbidimeters to be verified for the duration of the verification test
- Assist in installing the equipment in the test facilities and ensure proper operation before the test
- Perform on-site maintenance as necessary if turbidimeter fails any time during the test
- Review their respective draft verification reports and statements
- Remove and ship turbidimeters from the test site upon completion of the test.

3.3.3 EPA

EPA's responsibilities in the AMS pilot are based on the requirements stated in the "Environmental Technology Verification Program Quality and Management Plan of the Pilot Period

(1995-2000)” (QMP). The roles of the specific EPA staff are as follows:

Ms. Elizabeth Betz is EPA’s Pilot Quality Manager. For the verification test, Ms. Betz will:

- Review the draft test/QA plan
- Perform, at her option, one external technical system audit during the verification test
- Notify the Battelle Pilot Manager to facilitate a stop work order if external audit indicates that data quality is being compromised
- Prepare and distribute an assessment report summarizing results of external audit, if performed
- Review draft verification reports and statements.

Mr. Robert Fuerst is EPA’s Pilot Manager. As such, Mr. Fuerst will:

- Review the draft test/QA plan
- Approve the final test/QA plan
- Approve the final verification reports
- Review the draft verification statements.

3.3.4 Test Facilities

The verification test will be conducted at the Dublin Road Water Plant facilities in Columbus, Ohio. This host site will:

- Allow facility access to vendor, Battelle, and EPA representatives during the scheduled verification test including set-up and tear-down operations
- Define facility health and safety requirements to Battelle, EPA, and vendor staff who

may visit the testing facility

- Provide adequate working space during verification test
- Provide access to water flow of >15gpm
- Provide sufficient power for the simultaneous operation of all test equipment and technologies being verified
- Provide adequate laboratory space for operation of two benchtop turbidity monitors
- Provide appropriate facilities for standard solution preparation.

4. EXPERIMENTAL DESIGN

4.1. General Description of Test Procedures

This verification test will involve continuous monitoring of turbidity by multiple technologies. Throughout the testing period, a PC-based data acquisition system or data logger will be used to collect simultaneous measurements from the on-line turbidimeters at preset intervals. Grab samples will be collected concurrently with some of these measurements and analyzed using benchtop reference turbidimeters to provide a basis of comparison for the performance evaluations. The collection of grab samples will be timed to coincide as closely as possible with the recording of real-time turbidity measurements from the on-line monitoring technologies, and analysis of the grab samples will be performed as soon after the sample collection as possible to minimize possible temperature and settling effects.

The off-line phase of the test will be aimed at assessing the accuracy, precision, detection limit, and linearity of the turbidimeters relative to the standard methods. Additionally, response to various upset conditions will be quantified. As a means of testing these parameters, the off-line test phase will include the introduction of standard formazin solutions or other samples and the intentional upset of flow and water quality parameters. The on-line phase will focus on the long-term performance

characteristics of the technologies, including accuracy relative to the reference measurements and stability. The on-line phase will involve monitoring of a sample stream of variable turbidity within the treatment facility. Comparisons will be made to both EPA Method 180.1 and ISO 7027 to assess performance relative to these standard reference methods.

4.2. Reference Methods

Owing to the nature of turbidity measurement and the inherent differences in response arising from different instrumental designs, separate benchtop turbidimeters meeting the design criteria detailed in EPA Method 180.1 and ISO 7027 will be used for data comparisons in this test. A copy of Method 180.1 is provided in Appendix A. The ISO 7027 standard can be obtained directly from the International Organization for Standards, or can be downloaded for a fee from their website (www.iso.ch). Method 180.1 has been used historically for benchtop measurements and in the United States is the method used most commonly for reporting purposes. Internationally, ISO 7027 is used extensively for turbidity measurement. Both methods describe procedures to measure the nephelometric light scattering of a formazin solution albeit with different prescribed instrumental design parameters. The primary differences between these two standards are in the choice of light source. Method 180.1 requires the use of a broadband incandescent tungsten lamp, while ISO 7027 requires the use of a narrowband IR source. It is recognized that the results obtained from these methods are specific to the instrumental designs described in the respective methods and do not necessarily match exactly with responses from other designs. Consequently, to minimize biases introduced by a single reference method, both methods will be used for this verification test, and the performance of each vendor's turbidimeter will be compared to each of the reference methods.

4.3. Sample Introduction

The technologies to be verified under this test/QA plan measure turbidity on flowing sample streams as opposed to the static grab samples analyzed by the reference turbidimeters. Consequently, great care will be taken to ensure that the samples collected for reference analysis are representative of the sample flow measured by the technologies being verified. A specially designed manifold will be employed to provide identical sample streams to each of the turbidimeters being verified. An additional stream will provide the grab samples for the reference analysis. A schematic representation of this recirculation system is provided in Figure

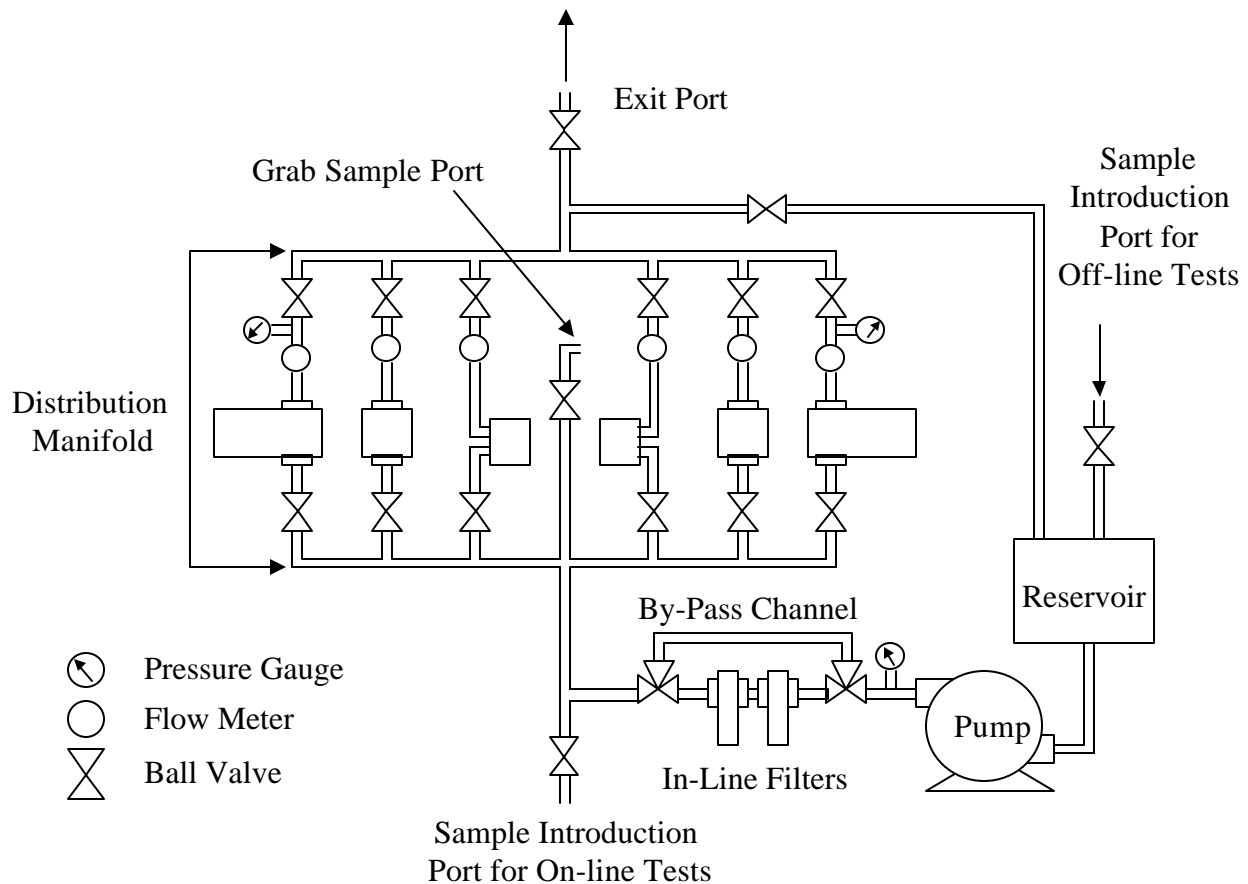

Figure 2. Schematic Representation of Recirculation System

2, and a further description of this system is provided in Section 7.3.

The design of the manifold will allow identical flow rates to be directed to each of the participating technologies and will allow for the turbidimeters to be switched easily from one to another of the manifold ports. Providing identical samples to each of the manifold ports should minimize any biases arising from water quality or turbulence issues; and rotation of the technologies to each of these ports in turn should help to identify if biases exist, and to allow for these biases to be accounted for in the subsequent data reduction.

To facilitate the rotation of turbidimeters among the available ports, the manifold will have identical ports with channels terminating with a mounting flange or similar adapter. The individual

turbidimeters to be verified will each have a mounting assembly appropriate for mating with any of the available ports. Battelle will provide an appropriate flow meter for use with each of the on-line turbidimeters to ensure the necessary flow conditions are met during verification.

4.4. Off-line Testing

The initial testing phase will involve off-line sample introduction. Use of off-line sample introduction provides the opportunity to challenge the capabilities of the technologies being verified not only by using prepared standard solutions of known turbidities, but also by intentionally upsetting the sample quality and flow parameters in a controlled fashion.

The basic response characteristics of these technologies will be assessed during the off-line test phase. A series of formazin solutions will be used to quantify the linearity and precision of these technologies in addition to their accuracy in measuring formazin solutions relative to the reference methods. The detection limit readings of these technologies will be established off-line by sampling very low turbidity water.

Additionally, the off-line testing will include monitoring the instrumental responses of these technologies to variations in water temperature, flow rate, and color. Each of these parameters will be varied over a range consistent with conditions encountered under typical plant operation. Table 1 summarizes the parameters to be evaluated during the off-line test phase. Procedures for performing this test phase are described in Section 5. Statistical comparisons to be made with the data are specified in Section 9.

4.5. On-line Testing

A list of the parameters to be evaluated on-line is provided in Table 2. The on-line test phase will focus on assessing the long-term performance of the turbidimeters under realistic operating conditions, and assessing the accuracy of these technologies in monitoring typical sample streams.

Specifically, this test phase will address the calibration and drift characteristics

Table 1. Summary of Parameters to be Evaluated in Off-Line Testing.

Parameter	Objective
Detection Limit	Determine the lowest turbidity measurable with a specified degree of certainty above background signal
Linearity	Determine linearity of response over the 0-5 NTU range
Accuracy	Determine the degree of agreement with the EPA and ISO reference methods using standard formazin solutions
Precision	Determine the degree of repeatability between successive measurements of the same sample
Response to Upset Conditions	Determine any measurable effects arising from changing operational parameters (i.e., temperature, flow rate, color.)

of the technologies over a period of exposure to a sample stream from an operating municipal water plant. Routine reference analyses recorded at the test facility will be used for comparison with the on-line readings to assess accuracy, and a reevaluation of the calibration at the end of the test period will help establish drift characteristics. Also, it is expected that natural meteorological occurrences will contribute to the variability of water quality in the treatment facility, and therefore provide a natural range of turbidity over which technology performance can be characterized.

Procedures for on-line testing are described in Section 5. Statistical comparisons to be made with the data are specified in Section 9.

5. TEST PROCEDURES

The procedures to be used in the verification test are detailed in this section. These procedures

will be followed for each technology being verified either simultaneously when possible, or sequentially when not. These procedures are designed to assess performance of the technologies being verified in realistic conditions. The number of measurements and the frequency of measurement represent a reasonable estimate of at least a minimum number of

Table 2. Summary of Parameters to be Evaluated in On-Line Testing.

Parameter	Objective
Accuracy	Determine the degree of agreement with the EPA and ISO reference methods using water samples from the plant
Effect of Real-World Variability	Assess the effect on accuracy of natural variability in factors such as temperature, meteorological influence, etc..
Drift	Determine the ability to retain calibration over extended field use

readings necessary to obtain statistically significant results.

In general, these procedures involve the collection of a grab sample which is timed to coincide as closely as possible to a recorded on-line measurement of turbidity, which is being measured continuously and recorded at scheduled intervals. Subsequent analysis of the grab sample in the reference turbidimeters will be used for comparison to the on-line measurements. The timing of the sample collection is critical in providing confidence that the reference sample is representative of the sample stream at the time of the on-line measurements. Consequently, if the grab sample is not collected within 30 seconds of the on-line turbidity measurements that sample will be discarded and a new sample will be collected; or if a sample is not analyzed within 3 minutes of collection, the results should be discarded and the procedure should be repeated for that sample.

One aim of the verification test is to assess the real-world variability of the technologies being tested. To that end, measurements which may appear to be anomalous with comparable data will be

retained in the data set. If an assignable cause can be identified, this cause will be described in the verification report.

5.1. Off-line Test

Characterization of the basic instrumental response to scattered light will include the establishment of a background reading and an assessment of the linearity, precision, and accuracy in instrumental response over the range from 0 - 5 NTU. The influence of water temperature, flow rate, and color will also be evaluated, each at two levels of turbidity.

5.1.1 Detection Limit

Establishment of a detection limit will be based on measurement of low turbidity water. These measurements will be used as an indication of the background level under the conditions of the verification test. Owing to the molecular scatter of light by water, a turbidity of zero is unachievable. However, to establish an experimental background, the recirculation system will be filled with tap water which will then undergo filtering for a minimum of 24 hours. During the filtering, the turbidity as measured by the on-line turbidimeters will be recorded as a means of monitoring particle removal.

The background readings will be recorded as a series of five measurements of the filtered water taken at intervals of at least 5 minutes each. Grab samples collected simultaneously will be analyzed by the reference turbidimeters and used for comparison. Before measurements are recorded, the calibration of the reference turbidimeters will be checked using a 0.5 NTU standard solution (Section 8.1.1). Additionally, a < 0.1 NTU standard solution will also be measured to ensure proper calibration (see Section 8.1.1) at low levels. As noted below, the effect of color on the background readings will also be assessed during this portion of the test.

The procedure for background measurement is as follows:

1. Fill recirculation system with tap water
2. Filter water for at least 24 hours
3. Ensure proper calibration of reference turbidimeters using 0.5 NTU solution and <0.1 NTU solution (Section 8.1.1)
4. Record turbidity readings of on-line turbidimeters and collect simultaneous grab sample
5. Analyze grab sample in reference turbidimeters and record results on data sheet (Appendix B)
6. Wait at least 5 minutes between on-line readings
7. Repeat steps 4 - 6 until five readings have been made on the filtered water
8. Ensure proper calibration of reference turbidimeters (Section 8.1.1)
9. Perform color effects test as described below (Section 5.1.6.).

After completion of the detection limit test, the in-line filters should be bypassed for the remaining tests.

5.1.2 Linearity

Linearity will be measured in the range from 0-5 NTU. Turbidity measurements will be recorded at 0.3, 0.5, 2, and 5 NTU through a series of successive additions of a 4000 NTU standard formazin stock solution. A freshly prepared 0.3 NTU solution will be introduced to the recirculation system and will be allowed to flow through the recirculation system for at least fifteen minutes before turbidity readings are recorded, to allow for complete homogenization. A series of five turbidity readings will be recorded per technology with at least a five minute interval between successive readings. These readings will be compared to the reference analysis of grab samples collected concurrently with each reading; that is, the turbidity of the solutions will be determined by measurement with the reference analyzers, rather than simply by calculations based on the dilution process. After the prescribed measurements have been recorded, 4000 NTU stock solution will be added to the recirculation system to increase the turbidity of the solution to the next value in the series. This series of

tests may be done immediately after the background reading is established (Section 5.1.1), and as noted below, include measurements to assess the influence of temperature, flow, and color.

The general procedure for the assessing linearity using formazin solutions is as follows:

1. Prepare 0.3 NTU standard solution
2. Ensure proper calibration of reference turbidimeters (Section 8.1.1)
3. Introduce 0.3 NTU standard to the recirculation system
4. Allow solution to flow through the system unfiltered for at least 15 minutes before recording first measurement
5. Record turbidity readings and collect grab sample
6. Analyze grab sample in reference turbidimeters and record results on data sheet (Appendix B)
7. Wait at least 5 minutes between on-line readings
8. Repeat steps 4-7 until five readings have been recorded
9. Ensure proper calibration of reference turbidimeters (Section 8.1.1)
10. For the 0.3 NTU and 5 NTU solutions repeat steps 4-9 at maximum specified flow and minimum specified flow for each turbidimeter
11. For the 0.3 NTU and 5 NTU solutions repeat steps 4-9 at 50 F and 80 F water bath temperatures. Record water temperature at manifold
12. For the 0.3 NTU solution, perform color effects test as described below (Section 5.1.6)
13. Rotate turbidimeter ports and record new positions
14. Add stock formazin solution to increase turbidity to next value in series
15. Repeat steps 3-14 for remaining solutions.

5.1.3 Accuracy and Precision

The data obtained from the detection limit and linearity evaluations will be used to establish accuracy and precision of the turbidimeters being verified with respect to measurement of formazin solutions. Accuracy will be assessed by comparison of continuous turbidity measurements to those from each of the two reference turbidimeters. Precision will be assessed on the five replicate results at each turbidity level. No further data will be acquired for these parameters.

5.1.4 Water Temperature

Variations in the temperature of the water stream will be introduced to simulate a range of conditions under which these technologies may typically operate. The temperature changes will be created by submersion of the system reservoir into a heat exchange bath. The bath temperature will be held at 50° +/- 5° F for one test and 80° +/- 5° F for another to represent a likely range of operating temperatures for these technologies. The solution will be allowed to recirculate for one hour to allow temperature equilibration. The temperature of the sample stream will be recorded at the grab sample port within 30 seconds of the sample collection, and the temperature of the grab sample will be measured within 30 seconds of the completion of the reference measurement. To assess temperature effects at different turbidities, this test will be conducted with 0.3 and 5 NTU formazin solutions.

5.1.5 Flow Rate

Changes in the flow rate of the feed stream will be manipulated to assess the response of the turbidimeters to various realistic operational conditions. A manual valve will be included on each of the manifold ports to allow the flow through each turbidimeter to be changed easily over a range indicated by the specifications of the individual turbidimeters. During normal testing the flow rate will be held at a

value specified by the technology vendor, or at a nominal value at the mid-point of the range specified. To assess the effect of flow rate on performance, a series of measurements will be made both at the minimum and maximum specified flow rate using 0.3 NTU and 5 NTU formazin solutions.

5.1.6 Color

Changes in water color will be introduced by spiking the sample stream with colored solutions which will be prepared as described in EPA Method 2120 B “Visual Comparison Method.”⁵ Stock solution will be added to the system reservoir to give sample solutions with approximately 5, 15, and 30 color units successively, and the instrumental response to these color changes will be monitored. This test will be conducted after establishment of the background using the low turbidity water, and after linearity, temperature, and flow tests using 5 NTU formazin solution.

The procedure for determining the effects of water color is:

1. Ensure proper calibration of reference turbidimeters (Section 8.1.1) and pH meter (Section 8.1.3)
2. Add stock color solution to reservoir containing filtered water for background measurements to approximately 5 color units
3. Allow solution to flow through the system unfiltered for at least 15 minutes
4. Record turbidity and collect grab sample
5. Analyze grab sample for turbidity, color, and pH and record results on data sheet (Appendix B)
6. Wait for at least 5 minutes between on-line readings
7. Repeat steps 4-6 until five readings have been recorded
8. Ensure proper calibration of reference turbidimeters (Section 8.1.1) and pH meter (Section 8.1.3)
9. Repeat steps 3-8 after adjusting color to approximately 15 color units, and again after

- adjusting to approximately 30 color units
10. Repeat steps 1-9 with 5 NTU solution
 11. Flush system.

Table 3 provides a summary of the various test solutions which will be evaluated in the off-line phase, the tests to be performed for each solution, and the number of readings to be recorded for each parameter. It is expected that these tests will be conducted over a period of two days. In some cases the data collected in testing for a certain parameter will also be used to assess another parameter. In such cases those parameters requiring no additional data acquisition are shown in parentheses.

5.2. On-Line Testing

Each turbidimeter will be calibrated by the vendor prior to off-line testing. If requested, turbidimeters normally calibrated with standards other than formazin may be recalibrated per the

Table 3. Summary of Measurements for Off-Line Verification Tests.

Test Sample	Parameter Tested	Number of Readings
Low turbidity water	Detection Limit (linearity, accuracy, precision, drift) ^a	5
	Color Effects	5 each at 5, 15, 30 CU
0.3 NTU Formazin	Linearity (accuracy, precision, drift)	5
	Flow Rate	5 each at maximum and minimum flow rate specification
	Temperature	5 each at high and low temperature

0.5 NTU Formazin	Linearity (accuracy, precision, drift)	5
2 NTU Formazin	Linearity (accuracy, precision, drift)	5
5 NTU Formazin	Linearity (accuracy, precision, drift)	5
	Flow Rate	5 each at maximum and minimum flow rate specification
	Temperature	5 each at high and low temperature
	Color Effects	5 each at 5, 15, 30 CU

a: () indicates collected data will be used in analyzing additional parameters

recommended procedures before the beginning of on-line testing. If recalibrated, the drift of these turbidimeters will be assessed on a relative rather than absolute basis.

5.2.1 Accuracy

The accuracy of the turbidimeters relative to the reference methods when reading water samples from the plant stream will be assessed on-line. A sample stream from the facility will be the source water for the distribution manifold and will be discharged to waste after sampling by the turbidimeters. Each weekday (Monday through Friday) for the four weeks of testing, two readings will be recorded per day.

The procedure to be followed is:

1. Ensure proper calibration of reference turbidimeters (Section 8.1.1)
2. Record turbidity and collect grab sample
3. Analyze grab sample in reference turbidimeters and record results on data sheet

(Appendix B)

4. Wait for at least 5 minutes between on-line readings
5. Repeat steps 2-3
6. Ensure proper calibration of reference turbidimeters (Section 8.1.1).

5.2.2 Real World Variability

The effects of real world variability in the turbidity of the sample stream will be assessed from continuously recorded data obtained throughout the on-line testing. Comparisons to the reference measurements will be made to show the general trend in turbidity as measured by the benchtop turbidimeters.

5.2.3 Drift

In general, each turbidimeter will be calibrated by the respective vendor after installation at the water plant and prior to the beginning of testing. After calibration no further adjustment will be performed for the duration of the verification test period, unless otherwise indicated in the technology instruction manual (e.g. weekly calibration, or cleaning), or if recalibration is conducted before on-line testing. The instrumental drift of the turbidimeters will be evaluated as part of the on-line test phase. Drift will be determined in two ways: 1) through off-line calibration checks using formazin solutions conducted regularly throughout the course of the verification test, and 2) through a comparison of multi-point linearity checks performed initially during the off-line phase and subsequently at the completion of the on-line phase.

The turbidimeters will be taken off-line briefly twice each week for routine calibration checks against a 0.5 NTU solution. These intermediate calibration checks will be performed twice weekly for

four consecutive weeks and will follow the procedure detailed above for linearity determination. For these calibration checks, freshly prepared 0.5 NTU formazin solutions will be used for the standard solution.

Upon completion of the four week period, the calibration of these turbidimeters will be checked once again through a comparison with the reference methods using standard solutions of 0.3, 0.5, 2, and 5 NTU. A linear fit of these data will be compared to the linear fit performed during the off-line test phase to assess the degree of calibration drift.

In general, the procedure is:

1. Ensure proper calibration of reference turbidimeters (Section 8.1)
2. Introduce 0.3 NTU solution to system
3. Recirculate solution for at least 30 minutes
4. Record turbidity and collect grab samples
5. Analyze grab sample in reference turbidimeter and record results on data sheet (Appendix B)
6. Wait for at least 5 minutes between on-line readings
7. Repeat steps 4-6 until 5 readings have been recorded
7. Ensure proper calibration of reference turbidimeters (Section 8.1.1)
8. Rotate turbidimeter ports and record new positions
9. Add stock solution to increase turbidity to next value in series
10. For final calibration check, repeat steps 2-9 with remaining solutions (0.5, 2, and 5 NTU standards).

Table 4 provides a summary of the various test solutions to be evaluated in the on-line phase, the tests to be performed for each solution, and the number of readings to be recorded for each parameter. In the cases where the data collected for the evaluation of one parameter is to be

Table 4. Summary of Measurements for On-Line Testing.

Test Solution	Parameter Tested	Number of Readings
Plant Water	Accuracy (Real world variability)	2 per weekday for 4 weeks (40 total)
0.3 NTU Standard	Drift	5 for final linearity check
0.5 NTU Standard	Drift	5 each for eight calibration checks and 5 for final linearity check
2 NTU Standard	Drift	5 for final linearity check
5 NTU Standard	Drift	5 for final linearity check

used to evaluate another parameter, the parameters requiring no additional data acquisition are shown in parentheses.

5.3. Schedule

The verification test, including set-up and tear-down operations, will be conducted over a period of approximately five weeks. The first part of the first week of this period is dedicated to installing the turbidimeters and ensuring proper operation. It is expected that the individual vendors will be available for one to two days during the set-up period to finalize installation of their turbidimeters. After the set-up period, off-line testing will be conducted. This test phase will follow in the same order as is listed in this test/QA plan. The on-line testing will then be conducted over the course of the next four weeks, ending with the final calibration check. After completion of both test phases, a period of two days will be set aside for tear-down operations at which point vendors will need to return to the test site to remove their turbidimeters. A generic schedule for testing activities is given in Table 5 below.

Table 5. Test Schedule

		Activity	Responsible Party
Week 1	Day 1	Set-up	Vendors and Battelle
	Day 2	Set-up	Vendors and Battelle
	Day 3	Set-up	Vendors and Battelle
	Day 4	Off-line tests	Battelle ^(a)
	Day 5	Off-line tests	Battelle ^(a)
Week 2		On-line tests, single point calibration checks	Battelle ^(a)
Week 3		On-line tests, single point calibration checks	Battelle ^(a)
Week 4		On-line tests, single point calibration checks	Battelle ^(a)
Week 5		On-line tests, single point calibration checks, final 5 point calibration check (day 5)	Battelle ^(a)
Week 6	Day 1	Tear-down	Vendors and Battelle
	Day 2	Tear-down	Vendors and Battelle

(a) On-site maintenance and repairs of turbidimeters will be performed by vendors on as needed basis

6. SITE DESCRIPTION

6.1. General Site Description

Under this test/QA plan, the verification test will be conducted at the Dublin Road Water Plant in Columbus, Ohio. This facility is an operating municipal water treatment facility which was

constructed in 1975. The plant treats an average of 50 million gallons of water daily and supplies the west, central and northwest areas of Columbus and Franklin County, and serves a population of ~ 330,000 people.

Source water for this plant is the Scioto River Watershed which has two in stream reservoirs, the O'Shaughnessy and Griggs, which hold approximately 4.8 billion and 1.4 billion gallons respectively. The watershed encompasses an area of approximately 2,000 square miles, which is predominately agricultural land.

6.2. Test Water Source

The water stream to be tested during verification will be drawn upstream from the effluent. Typically, the turbidity at this stage in the treatment process is between 0.2 and 2 NTU depending on external influences such as meteorological conditions. The water temperature is generally 72° F during July. The pH, total hardness, and total alkalinity are typically 9.25, 120 mg/L, and 54 mg/L, respectively.

6.3. Site Operation

The verification test will be coordinated and conducted by Battelle staff in cooperation with the on-site and managerial staff of the Dublin Road Water Plant facility. Responsibilities of the Battelle staff include calibration and operation of the reference turbidimeters, as well as grab sample collection and standard solution preparation. The technologies to be verified will be installed and prepared for testing with the assistance of vendor staff prior to testing to ensure proper operation. Routine operation of the verification test equipment will be the responsibility of Battelle, with cooperation of the site staff.

7. MATERIALS AND EQUIPMENT

7.1. Benchtop Reference Turbidimeters

The two benchtop turbidimeters used for the reference analyses will be designed to comply with the instrumental criteria prescribed in EPA Method 180.1 and ISO 7027 respectively. Each turbidimeter will be operated per the recommendations provided in their respective users manual.

7.2. Formazin Solutions

Formazin solutions for use as calibration standards for the benchtop turbidimeters and for the performance evaluation audit will be purchased from a commercial supplier (i.e., Hach Company, Loveland, CO). When available, stock solutions of the correct turbidity needed for calibration will be purchased. When not available, the standard solution will be prepared through the dilution of a purchased formazin solution using distilled, deionized water. A 0.3 NTU standard solution will be used as the initial solution for the off-line linearity tests. This solution will be prepared through dilution of a 100 NTU solution prepared from a purchased 4000 NTU stock solution. The turbidity of this solution will be varied for the remaining off-line linearity tests through successive additions of the 4000 NTU solution. The 0.5 NTU solution for the intermediate calibration checks will also be prepared from a 100 NTU stock solution prepared by dilution of a purchased 4000 NTU solution. A summary of the standard solutions to be used and the dilutions necessary for their preparation is provided in Table 6.

Preparation of diluted standard solutions will be performed within 24 hours of their use. Excess and waste solutions will be disposed of in accordance with the site procedures. When not in use, the glassware used for preparation and storage of these solutions will be kept scrupulously clean.

Table 6. Standard Solution Dilution Summary

Purpose	Stock Solution Turbidity (NTU)	Dilution Ratio	Turbidity of Final Solution (NTU)
Reference Turbidimeter Linearity Test	10	1:2	5
Reference Turbidimeter Linearity Test	10	1:5	2
Reference Turbidimeter Linearity Test	0.5	NA	0.5
Reference Turbidimeter Linearity Test	10	1:33	0.3
Reference Turbidimeter Linearity Test	<0.1	NA	< 0.1
Stock Solution for Off-Line Linearity Test and On-line Turbidimeter Calibration Check	4000	1:40	100
Initial Solution for the Off-line Turbidimeter Linearity Test	100	1:333	0.3
On-line Calibration Check	100	1:200	0.5

NA - Not applicable

7.3. Recirculation System

The recirculation system used for this verification test is shown schematically in Figure 2 (Section 4.3). This system will be designed and built at Battelle and will include the following basic components:

- a.) **Sample introduction port** - at least one port will be included to allow easy introduction of samples for both the off-line and on-line tests.

- b.) **Reservoir** - a small sample reservoir will be included. The size of the reservoir will be such that the total volume of solution in the system can be recirculated multiple times within a 15 minute period.
- c.) **Pump** - the recirculation pump will be a standard centrifugal pump and will have sufficient flow and pressure capabilities to meet the requirements of all the turbidimeters being verified.
- d.) **In-line filters** - a series of at least two in-line filters (0.4 - 1 μm) will be included in the system design for use in generating low turbidity water needed in the detection limit test.
- e.) **By-pass channel** - a channel will be included to allow flow to be directed around and not through the in-line filters as needed.
- f.) **Distribution manifold** - the distribution manifold will consist of several identical ports for the individual turbidimeters. Although during testing these ports may have different flow and requirements owing to the differences in technologies, the ports will be identical in design. In some cases, small tanks may be inserted to allow verification of submersible turbidimeters.
- g.) **Grab Sample Port** - an additional port will be included in the distribution manifold to allow grab samples to be collected.
- h.) **Exit port** - a port will be included to allow sample removal and appropriate disposal for both off-line and on-line testing.

The recirculation system will be designed and built to minimize the number of flow obstructions and potential sources of turbulence. All valves in the recirculation system will be either two or three way, full bore, ball valves. For each turbidimeter port, there will be a valve upstream and downstream of the turbidimeter to control flow and pressure. Additionally, a flow meter will be installed downstream of each turbidimeter, and if needed, a pressure gauge will be installed downstream of the turbidimeters. In general, the tubing will be a flexible plastic material appropriate for high purity applications, and the

diameter will be at least ½" to allow adequate flow for all the turbidimeters. Similarly, most connections will be made using hard plastic compression fittings, although in some cases, tubing of smaller diameter or different material, or other fittings may be used for certain portions of the system. Each turbidimeter will be installed per the recommendations of the respective vendor.

Before the test, the recirculation system will be checked by Battelle staff to ensure system integrity, including proper flow through each port, and adequate pumping capacity for recirculation. As part of the system check, a 0.5 NTU solution will be recirculated throughout the system and five grab samples from each of the ports will be collected and analyzed in the reference turbidimeters. The average of the five readings from each port must agree within 10% of the average of all the readings from all the ports before the verification test may begin.

7.4. Temperature Sensor

A thermocouple type temperature sensor will be used to monitor the ambient water temperature at the exit port of the recirculation system during the verification test. The room temperature in the vicinities of the recirculation system and the reference turbidimeters will be recorded daily using a calibrated thermometer. The calibration of these temperature sensors is the responsibility of Battelle and will be traceable to NIST standards. The calibration of each will be performed by the Battelle Instrument Lab within six months of the beginning of the verification test.

7.5. Flow Meter

Battelle will provide an appropriate flow meter for use in-line with each of the respective turbidimeters being verified. The flow meters will be used to ensure proper flow conditions are met during the verification test. These meters may not be identical since the flow requirements of the technologies being verified are likely to be quite different. The flow meters will be factory calibrated, or calibrated per the procedures recommended in the instruction manual, and each will be checked once

while in the recirculation system by measuring the time required to pass a known volume of liquid through the meter.

7.6. pH Meter

A pH meter will be used during the test of color effects. Calibration of the pH meter will be the responsibility of Battelle and will be traceable to NIST standards. Calibration will be performed according to the manufacturer's recommendations. The calibration will be conducted within 1 hour of the beginning and within 1 hour of the conclusion of the color test.

7.7. Data Acquisition System

A PC-based data acquisition system will be supplied by Battelle to record and store simultaneous turbidity measurements from each of the on-line turbidimeters. The 4-20 mA outputs of the turbidimeters will be recorded using this system. This system will be compatible with the capabilities of the technologies being verified and will be used for data acquisition and storage.

8. QUALITY ASSURANCE/QUALITY CONTROL

8.1. Calibration

8.1.1 Reference Turbidimeters

Calibration of the benchtop reference turbidimeters in the range from 0-5 NTU will be performed before the verification test begins. This calibration will follow the procedures described in the manuals of the respective turbidimeters and will adhere to the requirements set forth in Method

180.1 or ISO 7027 appropriately. Before proceeding with the verification test the calibration of each reference turbidimeter will be checked through a five-point linearity test. The calibration check will involve a linear fit of the turbidimeter readings using primary standard solutions with turbidities of <0.1, 0.3, 0.5, 2, and 5 NTU. For each reference turbidimeter, the slope of this linear fit must be between 0.90 and 1.10 and have an $r^2 > 0.98$.

Calibration of these turbidimeters will be checked both before and after each series of test measurements, using a 0.5 NTU standard solution. The reference turbidimeters will be recalibrated if agreement between the turbidity reading and the turbidity value of this standard solution is not within 10% (i.e., .45 - .55 NTU). If the calibration check criteria are met before but not after a series of measurements are performed, the procedures for those measurements must be repeated after recalibration of the reference turbidimeter.

Before the background readings are measured for the detection limit determination (Section 5.1.1), an additional calibration check with < 0.1 NTU solution will also be measured in the reference turbidimeters to ensure proper calibration at low levels. If agreement between the turbidity reading and the < 0.1 NTU standard solution turbidity is not within 0.02 NTU of the value reported on the certificate of analysis (COA), the reference turbidimeter will be recalibrated.

When available, the standards used in the calibration, or calibration check, will be purchased with the appropriate turbidity value for direct evaluation. Otherwise, the standard solution will be prepared through subsequent dilution of stock solution with distilled, deionized water using Class A volumetric glassware.

8.1.2 Temperature Sensors

The thermocouple sensor used to determine water temperature, and the thermometer used to measure room temperature, must have been calibrated against a certified temperature measurement standard by the Battelle Instrument Laboratory within the six months prior to the beginning of the verification test. At least once during the verification test each temperature measuring device will be

checked for accuracy by comparison to an American Society for Testing and Materials (ASTM) mercury-in-glass thermometer. That comparison will be done at ambient temperature and must result in agreement with the reference thermometer within 2° C.

8.1.3 Flow Meters

Each flow meter will be factory calibrated and will be checked once during the verification test by measuring the time required to pass a known volume of liquid through the individual meters. If the calibration check indicates an error in excess of 10%, the meter will be recalibrated, when feasible, or replaced.

8.1.4 pH Meter

Calibration will include standardization at a pH of 7 and a pH of 10 using commercial buffer solutions. Calibration of the pH meter will be performed within 1 hour of the beginning of each phase of the color test (i.e., low turbidity water, and 5 NTU formazin solution), and will be checked within 10 minutes of the completion of series of color measurements (i.e., 5, 15, 30 color units). The meter reading and the nominal buffer value must agree within 0.2 pH units or the color readings will be repeated.

Table 7 summarizes the QA/QC activities, the acceptance criteria, and the planned corrective actions.

8.2. Data Collection

The data to be acquired and the means by which it is to be recorded are detailed in Section 9.1. In general, electronic data will be collected and stored by a PC-based data acquisition system or data logger and manual data collection will be conducted by Mr. Satola. Example data sheets to be

used for recording purposes are shown in Appendix B.

To ensure consistency, Mr. Satola will conduct all sample collection and reference method analysis, as well as the preparation of all standard solutions when possible. If Mr. Satola is unavailable (e.g., owing to an illness, or conflicting work assignment), another representative of Battelle, who has been trained in the procedures used by Mr. Satola, will be responsible for these duties. However, it is planned that to the extent possible, a single operator will be responsible for these activities.

Table 7. Quality Assurance Criteria for Calibration

Activity	Acceptance Criteria	Corrective Action
Reference turbidimeter calibration	$0.90 < \text{slope} < 1.10$ $r^2 > 0.98$	Recalibration
Reference turbidimeter calibration check	0.5 NTU +/- 10% +/- 0.02 of COA value for < 0.1 NTU	Recalibration, repeat sample collection and analysis from previous calibration
Temperature sensor check	+/- 2° C of reference temperature reading	Recalibration
Flow meter check	+/- 10%	Recalibration or replacement
pH Meter check	+/- 0.2 pH units	Recalibration, repeat sample collection and analysis from previous calibration

8.3. Assessments and Audits

8.3.1 Technical Systems Audit

Battelle's QA/QC Reviewer, Ms. Susan Abby, will perform a technical systems audit once during the performance of this verification test. The purpose of this audit is to ensure that the verification test is being performed in accordance with this test/QA plan and that all QA/QC procedures are being implemented. In this audit, Ms. Abby will review the calibration standards and reference methods used, compare actual test procedures to those specified in this plan, and review data acquisition and handling procedures.

8.3.2 Performance Evaluation Audit

Performance evaluation audits will be conducted to assess the quality of the measurements made in this verification test. These audits address only those measurements made by Battelle staff in conducting the verification test, i.e., the reference turbidimeters readings, pH, and temperature measurements. The audits will be conducted by analyzing standards or comparing to references which are independent of those used in the verification test. The standards or references to be used in these audits are listed in Table 8. Each audit will be made once during the verification test period.

The audit of the reference turbidimeters will be performed by analyzing a standard formazin solution and comparing to a reference that is independent of standards used during the test (i.e., AMCO-AEPA-1 standard solution). This audit will be performed once during the verification procedure and will occur after initial calibration of the reference turbidimeters. Battelle's QA/QC Reviewer will be present during the performance evaluation audit to immediately assess audit results. Agreement between the formazin solution turbidity readings and AMCO-AEPA-1 must be within 10% for each reference turbidimeter. If this criterion is not met, the reference turbidimeter showing the disagreement must be recalibrated.

The audit of the temperature sensors will be conducted by comparison to an independent

temperature sensor (i.e., ASTM mercury-in-glass thermometer). That comparison will be done at ambient temperature and must result in agreement with the reference thermometer within 2° C , or recalibration of the temperature sensors will be performed.

Performance of the pH meter will be audited through the measurement of independent buffer solutions. Agreement between the meter reading and the nominal pH of the buffer solution must be within 0.2 pH units, otherwise recalibration of the pH meter will be performed.

Table 8. Performance Audit Summary

Audited Measurement	Audit Standard or Reference
Reference turbidity	AMCO-AEPA-1 Polymer turbidity standard
Temperature	ASTM thermometer
pH	Independent buffer solution

8.3.3 Verification Test Data Audit

Battelle's QA/QC Reviewer will audit at least 10 percent of the verification data acquired during the verification test. The QA/QC Reviewer will trace the data from initial acquisition, through reduction and statistical comparisons, and to final reporting. All calculations performed on the data undergoing the audit will be checked.

8.4. Audit Reporting

Each assessment and audit will be documented in accordance with Section 2.9.7 of the QMP for the AMS pilot.¹ Assessment reports will include the following:

- Identification of any adverse findings or potential problems
- Response to adverse findings or potential problems
- Possible recommendations for resolving problems
- Citation of any noteworthy practices that may be of use to others
- Confirmation that corrective actions have been implemented and are effective.

8.5. Corrective Action

The QA/QC Reviewer during the course of any assessment or audit will identify to the technical staff performing experimental activities any immediate corrective action that should be taken. If serious quality problems exist, the Battelle QA/QC Reviewer is authorized to stop work. Once the assessment report has been prepared, the Verification Test Coordinator will ensure that a response is provided for each adverse finding or potential problem, and will implement any necessary follow-up corrective action. The QA/QC Reviewer will ensure that follow-up corrective action has been taken.

9. DATA ANALYSIS AND REPORTING

9.1. Data Acquisition

Data acquisition in this verification test includes recording of the response data from the turbidimeters being verified and recording the data from the reference turbidimeters, in addition to

documentation of test conditions including water temperature, sample flow rates, and other operational parameters.

Results from the turbidimeters being verified will be recorded automatically based on a preprogrammed monitoring schedule. The results will be transmitted electronically and stored in a central data acquisition system (e.g., laptop computer or data logger.) Grab sample collection for measurement by the reference turbidimeters will be timed to coincide as closely as possible with the recorded measurements of the on-line turbidimeters. Analysis of the grab samples will be performed as quickly as possible and the results from the reference turbidimeters will be recorded in laboratory notebooks by Battelle staff. If the grab sample is not collected within 30 seconds of the on-line turbidity measurements, or if the sample is not analyzed within 3 minutes of collection, the results should be discarded and the procedure should be repeated for that sample. These results will be supplemented by pertinent data regarding test conditions.

A summary of the data acquisition process is provided in Table 9. This table includes the type of data to be recorded, how or where the data are to be recorded, the frequency of measurement, and the disposition of the data once recorded. Results for each technology will be imported into an appropriate software package with the corresponding reference and condition data for subsequent reduction and analysis. The format of the data files will be identical for each technology being verified to ensure uniform data treatment.

In all cases, strict confidentiality of data will be maintained for each participating vendor. This will be accomplished in part by storing electronic data under separate and clearly identifiable computer file names for each turbidimeter. All hard copy information similarly will be maintained in separate files for each turbidimeter. At no time during the verification test will Battelle engage in any comparison or discussion of test data, or of different turbidimeters.

9.2. Summary of Verification Test Data

Table 10 lists the total number of samples or conditions, the number of readings per sample or

condition, and the total number of readings to be made for each of the tests for both the off-line and on-line tests. These measurements will be used in the statistical calculations used for the data comparisons. Data recorded during the testing of one parameter may be used in evaluating other parameters (see Table 3 and Table 4).

9.3. Statistical Calculations

Performance characterization is based on statistical comparisons of continuous turbidimeter results to results from the reference methods.

9.3.1 Detection Limit

The detection limit (LOD) will be defined as the smallest true turbidity at which the turbidimeter's expected response exceeds the calibration curve at the background reading (α_0) by

Table 9. Summary of Data Recording Process for the Verification Test

Data to be Recorded	Where Recorded	How Often Recorded	Disposition of Data
Dates, times of test events	Laboratory record books, data sheets, and electronic data systems	Start/end of test, and at each change of a test parameter, or collection of a grab sample.	Used to compile and check test results; manually incorporated in data spreadsheets as necessary.
Test parameters (temperature, flow, color, pH, and turbidity, etc.)	Laboratory record books, data sheets, and electronic data system, if feasible	When set or changed, or as needed to document test conditions.	Used as part of test results, manually incorporated in data spreadsheets as necessary.
On-line turbidimeter readings - electronic output	Data acquisition system (data logger, PC, laptop, etc.).	At specified acquisition times throughout each test.	Electronically transferred to spreadsheets.
On-line turbidimeter performance (ease of use, reliability, maintenance, etc.)	Laboratory notebook, data sheets	During set-up and tear-down periods; daily during testing, and as needed.	Used as part of test results; incorporated into verification report.
Reference turbidimeter readings	Reference data sheets for EPA Method 180.1 and ISO 7027 methods	At each analysis of a standard or sample by either reference turbidimeter.	Transferred to spreadsheets
pH Meter and Temperature Sensor Calibration Results	Laboratory record book	At calibration	Used to compile and check test results; manually incorporated in data spreadsheets as necessary.
Preparation of Standard Solutions	Laboratory record book	During solution preparation	Used to compile and check test results; manually incorporated in data spreadsheets as necessary.

Table 10. Sampling Summary

Parameter	Test Phase	Number of Conditions or Samples	Number of Readings per Condition	Total Number of Readings to be Collected for Each Turbidimeter
Detection limit	Off-line	1	5	5
Linearity	Off-line	4	5	20
Water Temp	Off-line	4	5	20
Flow Rate	Off-line	4	5	20
Color	Off-line	6	5	30
Accuracy	On-line	20	2	40
Intermediate Drift	On-line	8	5	40
Calibration Drift	On-line	4	5	20

three times the standard deviation (σ_o) of the turbidimeter's background reading, i.e., $\hat{a}_o + 3 \hat{\sigma}_o$. The LOD may then be determined by

$$LOD = \frac{[(\hat{a}_o + 3\hat{\sigma}_o) \hat{a}_o]}{\hat{a}_1} = \frac{3\hat{\sigma}_o}{\hat{a}_1}$$

where $\hat{\sigma}_o$ is the estimated standard deviation at the instrumental background. The LOD is estimated as

$$LOD = 3\hat{a}_o/\hat{a}_1.$$

9.3.2 Linearity

Linearity will be assessed by linear regression with the calibration turbidity as independent variable and the turbidimeter response as dependent variable. The calibration model is

$$Y_c = h(c) + error_c$$

where Y_c is the response of the turbidimeter to a standard solution turbidity c , $h(c)$ is a linear calibration curve, and the error term is assumed to be normally distributed.

9.3.3 Accuracy

The relative accuracy (A) of the turbidimeters with respect to the reference methods will be assessed by:

$$A = \frac{|\bar{R} - \bar{T}|}{\bar{R}} \times 100$$

where the bars indicate the mean of the reference (R) and on-line turbidimeter (T) results on corresponding samples.

Accuracy relative to the reference turbidimeters will be assessed both for the standard formazin solutions and the samples from the plant water stream. The accuracy of each on-line turbidimeter will be assessed separately relative to each of the two reference turbidimeters.

9.3.4 Precision

Precision will be reported in terms of the percent relative standard deviation (RSD) of a group

of similar measurements. For a set of turbidity measurements given by T_1, T_2, \dots, T_n , the standard deviation (S) of these measurements is:

$$S = \left[\frac{1}{n-1} \sum_{k=1}^n (T_k - \bar{T})^2 \right]^{1/2}$$

where \bar{T} is the average of the turbidity readings. The RSD is calculated from:

$$RSD = \left| \frac{S}{\bar{T}} \right| \times 100$$

and is a measure of the measurement uncertainty relative to the absolute value of the measurement. This approach will be applied to groups of five replicate measurements on test solutions.

9.3.5 Water Temperature Effects

For a given turbidity, the turbidimeter response data at each water temperature will be averaged. Thus, at 0.3 NTU and 5 NTU there will be three data points for each turbidimeter, namely the average turbidity at room temperature, low temperature, and high temperature. The water temperature effect at these turbidities will then each be assessed by trend analysis, using separate linear regression analyses for the 0.3 NTU and 5 NTU data.

9.3.6 Flow Rate Sensitivity

Analysis of flow rate influence on turbidity readings will be similar to that used for assessing temperature effects. The turbidimeter response data at each flow rate will be averaged and analyzed separately for the 0.3 NTU and 5 NTU data.

9.3.7 Color Effects

The influence of color on turbidity will be assessed through a linear regression analysis of the average values of turbidity measured at each color. Separate analyses will be performed for the background measurements and those recorded at 5 NTU.

9.3.8 Drift

Drift will be assessed in two ways. The calibration drift will be assessed through a comparison of the regression analyses of the multi-point linearity test performed at the beginning and the end of the verification test. A comparison of the regression results of these two sets of data will be used to help establish any long term drift observed during the verification test. A linear regression analysis of the intermediate drift data will be used to help assess instrumental drift characteristics. The slope and associated uncertainty will be used to determine if intermediate drift was observed over all or portions of the verification test period.

9.4. Data Review

Records generated by Battelle staff in the verification test will receive a one-over-one review within two weeks after generation, before these records are used to calculate, evaluate, or report verification results. These records may include laboratory record books; operating data from the combustion sources; equipment calibration records; and data sheets used to record the turbidimeters' response or other parameters in the laboratory or combustion source experiments. This review will be performed by a Battelle technical staff member involved in the verification test, but not the staff member that originally generated the record. The review will be documented by the person performing the review by adding his/her initials and date to a hard copy of the record being reviewed. This hard copy

will then be returned to the Battelle staff member who generated or who will be storing the record.

In addition, data calculations performed by Battelle will be spot-checked by Battelle technical staff to ensure that calculations are performed correctly. Calculations to be checked include determination of turbidimeter precision, accuracy, detection limit, and other statistical calculations identified in Section 8.2 of this test/QA plan.

9.5. Reporting

The statistical data comparisons that result from each of the tests described above will be conducted separately for each turbidimeter, and information on the additional cost factors will be compiled. Separate verification reports will then be prepared, each addressing the turbidimeter provided by one commercial vendor. For each test conducted in this verification, the verification report will present the test data, as well as the results of the statistical evaluation of those data.

The verification report will briefly describe the ETV program and the AMS pilot, and will describe the procedures used in the verification test. These sections will be common to each verification report resulting from this verification test. The results of the verification test will then be stated quantitatively, without comparison to any other turbidimeter tested, or comment on the acceptability of the turbidimeter's performance. The preparation of draft verification reports, the review of reports by vendors and others, the revision of the reports, final approval, and the distribution of the reports, will be conducted as stated in the Generic Verification Protocol for the Advanced Monitoring Systems Pilot.⁷ Preparation, approval, and use of verification statements summarizing the results of this test will also be subject to the requirements of that same Protocol.

10. HEALTH AND SAFETY

10.1. General

All verification testing described in this test/QA plan will be performed at the Dublin Water Plant in Columbus, Ohio. The management of this facility will review the necessary health and safety requirements and guidance for this facility with Battelle and vendor staff before the verification test begins. Battelle staff involved in this verification test will operate under these established requirements and guidelines as well as under appropriate procedures covered in the Battelle Safety Manual. Specifically, the use of personal protective equipment, as defined in procedure SIH-PP-01, will be used, and the chemical safety protocols set forth in SIH-PP-05 will be followed. It is expected that while on site, all vendor representatives will operate according to the site requirements.

10.2. Potential Hazards

10.2.1 Hydrazine Sulfate

Formazin solutions contain residual hydrazine sulfate $[(\text{NH}_2)_2\text{H}_2\text{SO}_4]$ which is a known carcinogenic material.² Appropriate precautions will be taken when handling formazin solutions, including the use of proper personal protective equipment (i.e., safety glasses, gloves, laboratory coat). These solutions should be stored in a well ventilated area and when feasible these solutions will be handled in a fume hood. The solutions will remain in properly labeled containers or vessels at all times, including during use in the recirculation system. Waste or excess solution will be disposed of properly in accordance with site requirements.

10.2.2 Concentrated Acids

Preparation of stock color solutions requires the use of concentrated acids. Appropriate precautions, including the use of proper personal protective equipment, will be taken when handling these acids or stock solutions. Waste or excess solutions will be disposed of properly in accordance

with site requirements.

11. DEFINITIONS

Accuracy – The degree of agreement between the response of the turbidimeter with that of the reference method determined from simultaneous sampling from identical sources.

Background - The response of a turbidimeter to very low turbidity water under the conditions of testing.

Calibration – Adjustment of a turbidimeter’s response to one or more formazin standard solutions.

Calibration Check – Observation of the response of a turbidimeter to a standard solution.

Detection Limit - The turbidity at which the response of the turbidimeter equals three times the standard deviation of the noise level at the instrumental background.

Drift – The degree to which the response of a turbidimeter to standard solutions changes over time.

Linearity – The linear proportional relationship expected between analyte turbidity and turbidimeter response over a given measuring range of the turbidimeter.

Nephelometer – A device used for the measurement of light scattering in which the light source and the detector are arranged to detect perpendicular scattering.

Nephelometric Turbidity Unit - NTU – A numerical quantity of the turbidity of a solution based on a nephelometric measurement.

Precision - The degree of mutual agreement between successive readings of the same sample solution.

Turbidimeter - A technology used for the measurement of turbidity in liquids.

Turbidity – The reduction of transparency of a liquid caused by the presence of undissolved matter.³

12. REFERENCES

1. “Quality Management Plan (QMP) for the ETV Advanced Monitoring Systems Pilot”, U. S. Environmental Protection Agency Environmental Technology Verification Program, prepared by Battelle, Columbus, Ohio, September 1998.
2. “Determination of Turbidity by Nephelometry”, Methods for the Determination of Inorganic Substances in Environmental Samples, Method 180.1, EPA/600/R-93/100, U. S. Environmental Protection Agency, Cincinnati, Ohio, August 1993.
3. “Standard Test Method for Turbidity of Water”, Annual Book of ASTM Standards, American Society for Testing and Materials, D 1889-94, May 15, 1994.
4. “Water Quality – Determination of Turbidity”, International Standard ISO 7027, Second Edition, International Organization for Standardization, Geneva, 1990.
5. “Color in Water by Visual Comparison to Standards”, Standard Methods for the Examination of Water and Wastewater, 18th Edition, Method 2120-B, American Public Health Association, 1992.
6. “Generic Verification Protocol for the Advanced Monitoring Systems Pilot”, U. S. Environmental Protection Agency Environmental Technology Verification Program, prepared by Battelle, Columbus, Ohio, October 1998.
7. “Environmental Technology Verification Program Quality and Management Plan for the Pilot Period (1995-2000)”, EPA-600/R-98/064, U. S. Environmental Protection Agency, Cincinnati, Ohio, May 1998.

APPENDIX A

EPA METHOD 180.1

APPENDIX B

EXAMPLE DATA SHEETS

METHOD 180.1

DETERMINATION OF TURBIDITY BY NEPHELOMETRY

Edited by James W. O'Dell
Inorganic Chemistry Branch
Chemistry Research Division

Revision 2.0
August 1993

ENVIRONMENTAL MONITORING SYSTEMS LABORATORY
OFFICE OF RESEARCH AND DEVELOPMENT
U.S. ENVIRONMENTAL PROTECTION AGENCY
CINCINNATI, OHIO 45268

180.1-1

1.0 SCOPE AND APPLICATION

- 1.1 This method covers the determination of turbidity in drinking, ground, surface, and saline waters, domestic and industrial wastes.
- 1.2 The applicable range is 0 to 40 nephelometric turbidity units (NTU). Higher values may be obtained with dilution of the sample.

2.0 SUMMARY OF METHOD

- 2.1 The method is based upon a comparison of the intensity of light scattered by the sample under defined conditions with the intensity of light scattered by a standard reference suspension. The higher the intensity of scattered light, the higher the turbidity. Readings, in NTUs, are made in a nephelometer designed according to specifications given in sections 6.1 and 6.2. A primary standard suspension is used to calibrate the instrument. A secondary standard suspension is used as a daily calibration check and is monitored periodically for deterioration using one of the primary standards.
 - 2.1.1 Formazin polymer is used as a primary turbidity suspension for water because it is more reproducible than other types of standards previously used for turbidity analysis.
 - 2.1.2 A commercially available polymer primary standard is also approved for use for the National Interim Primary Drinking Water Regulations. This standard is identified as AMCO-AEPA-1, available from Advanced Polymer Systems.

3.0 DEFINITIONS

- 3.1 CALIBRATION BLANK (CB) - - A volume of reagent water fortified with the same matrix as the calibration standards, but without the analytes, internal standards, or surrogates analytes.
- 3.2 INSTRUMENT PERFORMANCE CHECK SOLUTION (IPC) - - A solution of one or more method analytes, surrogates, internal standards, or other test substances used to evaluate the performance of the instrument system with respect to a defined set of criteria.
- 3.3 LABORATORY REAGENT BLANK (LRB) - - An aliquot of reagent water or other blank matrices that are treated exactly as a sample including exposure to all glassware, equipment, solvents, reagents, internal standards, and surrogates that are used with other samples. The LRB is used to determine if

method analytes or other interferences are present in the laboratory environment, the reagents, or the apparatus.

- 3.4 LINEAR CALIBRATION RANGE (LCR) - - The concentration range over which the instrument response is linear.
 - 3.5 MATERIAL SAFETY DATA SHEET (MSDS) - - Written information provided by vendors concerning a chemical's toxicity, health hazards, physical properties, fire, and reactivity data including storage, spill, and handling precautions.
 - 3.6 PRIMARY CALIBRATION STANDARD (PCAL) - - A suspension prepared from the primary dilution stock standard suspension. The PCAL suspensions are used to calibrate the instrument response with respect to analyte concentration.
 - 3.7 QUALITY CONTROL SAMPLE (QCS) - - A solution of the method analyte of known concentrations that is used to fortify an aliquot of LRB matrix. The QCS is obtained from a source external to the laboratory, and is used to check laboratory performance.
 - 3.8 SECONDARY CALIBRATION STANDARDS (SCAL) - - Commercially prepared, stabilized sealed liquid or gel turbidity standards calibrated against properly prepared and diluted formazin or styrene divinylbenzene polymers.
 - 3.9 STOCK STANDARD SUSPENSION (SSS) - - A concentrated suspension containing the analyte prepared in the laboratory using assayed reference materials or purchased from a reputable commercial source. Stock standard suspension is used to prepare calibration suspensions and other needed suspensions.
- 4.0 INTERFERENCES
- 4.1 The presence of floating debris and coarse sediments which settle out rapidly will give low readings. Finely divided air bubbles can cause high readings.
 - 4.2 The presence of true color, that is the color of water which is due to dissolved substances that absorb light, will cause turbidities to be low, although this effect is generally not significant with drinking waters.
 - 4.3 Light absorbing materials such as activated carbon in significant concentrations can cause low readings.

5.0 SAFETY

- 5.1 The toxicity or carcinogenicity of each reagent used in this method has not been fully established. Each chemical should be regarded as a potential health hazard and exposure should be as low as reasonably achievable.
- 5.2 Each laboratory is responsible for maintaining a current awareness file of OSHA regulations regarding the safe handling of the chemicals specified in this method. A reference file of Material Safety Data Sheets (MSDS) should be made available to all personnel involved in the chemical analysis. The preparation of a formal safety plan is also advisable.
- 5.3 Hydrazine Sulfate (7.2.1) is a carcinogen. It is highly toxic and may be fatal if inhaled, swallowed, or absorbed through the skin. Formazin can contain residual hydrazine sulfate. Proper protection should be employed.

6.0 EQUIPMENT AND SUPPLIES

- 6.1 The turbidimeter shall consist of a nephelometer, with light source for illuminating the sample, and one or more photo-electric detectors with a readout device to indicate the intensity of light scattered at right angles to the path of the incident light. The turbidimeter should be designed so that little stray light reaches the detector in the absence of turbidity and should be free from significant drift after a short warm-up period.
- 6.2 Differences in physical design of turbidimeters will cause differences in measured values for turbidity, even though the same suspension is used for calibration. To minimize such differences, the following design criteria should be observed:
 - 6.2.1 Light source: Tungsten lamp operated at a color temperature between 2200-3000E.
 - 6.2.2 Distance traversed by incident light and scattered light within the sample tube: Total not to exceed 10 cm.
 - 6.2.3 Detector: Centered at 90E to the incident light path and not to exceed $\pm 30E$ from 90E. The detector, and filter system if used, shall have a spectral peak response between 400 and 600 nm.
- 6.3 The sensitivity of the instrument should permit detection of a turbidity difference of 0.02 NTU or less in waters having turbidities less than 1 unit. The instrument

should measure from 0 to 40 units turbidity. Several ranges may be necessary to obtain both adequate coverage and sufficient sensitivity for low turbidities.

- 6.4 The sample tubes to be used with the available instrument must be of clear, colorless glass or plastic. They should be kept scrupulously clean, both inside and out, and discarded when they become scratched or etched. A light coating of silicon oil may be used to mask minor imperfections in glass tubes. They must not be handled at all where the light strikes them, but should be provided with sufficient extra length, or with a protective case, so that they may be handled. Tubes should be checked, indexed and read at the orientation that produces the lowest background blank value.
- 6.5 Balance - - Analytical, capable of accurately weighing to the nearest 0.0001 g.
- 6.6 Glassware - - Class A volumetric flasks and pipettes as required.

7.0 REAGENTS AND STANDARDS

- 7.1 Reagent water, turbidity-free: Pass deionized distilled water through a 0.45 μ m pore size membrane filter, if such filtered water shows a lower turbidity than unfiltered distilled water.
- 7.2 Stock standard suspension (Formazin):
- 7.2.1 Dissolve 1.00 g hydrazine sulfate, (NH₂)₂.H₂SO₄, (CASRN 10034-93-2) in reagent water and dilute to 100 mL in a volumetric flask.
CAUTION - - CARCINOGEN
- 7.2.2 Dissolve 10.00 g hexamethylenetetramine (CASRN 100-97-0) in reagent water and dilute to 100 mL in a volumetric flask. In a 100 mL volumetric flask, mix 5.0 mL of each solution (7.2.1 + 7.2.2). Allow to stand 24 hours at 25 ± 3°C, then dilute to the mark with reagent water.
- 7.3 Primary calibration standards: Mix and dilute 10.00 mL of stock standard suspension (7.2) to 100 mL with reagent water. The turbidity of this suspension is defined as 40 NTU. For other values, mix and dilute portions of this suspension as required.
- 7.3.1 A new stock standard suspension (7.2) should be prepared each month. Primary calibration standards (7.3) should be prepared daily by dilution of the stock standard suspension.

- 7.4 Formazin in commercially prepared primary concentrated stock standard suspension (SSS) may be diluted and used as required. Dilute turbidity standards should be prepared daily.
- 7.5 AMCO-AEPA-1 Styrene Divinylbenzene polymer primary standards are available for specific instruments and require no preparation or dilution prior to use.
- 7.6 Secondary standards may be acceptable as a daily calibration check, but must be monitored on a routine basis for deterioration and replaced as required.

8.0 SAMPLE COLLECTION, PRESERVATION AND STORAGE

- 8.1 Samples should be collected in plastic or glass bottles. All bottles must be thoroughly cleaned and rinsed with turbidity free water. Volume collected should be sufficient to insure a representative sample, allow for replicate analysis (if required), and minimize waste disposal.
- 8.2 No chemical preservation is required. Cool sample to 4EC.
- 8.3 Samples should be analyzed as soon as possible after collection. If storage is required, samples maintained at 4EC may be held for up to 48 h.

9.0 QUALITY CONTROL

- 9.1 Each laboratory using this method is required to operate a formal quality control (QC) program. The minimum requirements of this program consist of an initial demonstration of laboratory capability and analysis of laboratory reagent blanks and other solutions as a continuing check on performance. The laboratory is required to maintain performance records that define the quality of data generated.
- 9.2 INITIAL DEMONSTRATION OF PERFORMANCE.
 - 9.2.1 The initial demonstration of performance is used to characterize instrument performance (determined of LCRs and analysis of QCS).
 - 9.2.2 Linear Calibration Range (LCR) - - The LCR must be determined initially and verified every 6 months or whenever a significant change in instrument response is observed or expected. The initial demonstration of linearity must use sufficient standards to insure that the resulting curve is linear. The verification of linearity must use a minimum of a blank and

three standards. If any verification data exceeds the initial values by $\pm 10\%$, linearity must be reestablished. If any portion of the range is shown to be nonlinear, sufficient standards must be used to clearly define the nonlinear portion.

- 9.2.3 Quality Control Sample (QCS) - - When beginning the use of this method, on a quarterly basis or as required to meet data-quality needs, verify the calibration standards and acceptable instrument performance with the preparation and analysis of a QCS. If the determined concentrations are not within $\pm 10\%$ of the stated values, performance of the determinative step of the method is unacceptable. The source of the problem must be identified and corrected before continuing with on-going analyses.

9.3 ASSESSING LABORATORY PERFORMANCE

- 9.3.1 Laboratory Reagent Blank (LRB) - - The laboratory must analyze at least one LRB with each batch of samples. Data produced are used to assess contamination from the laboratory environment.
- 9.3.2 Instrument Performance Check Solution (IPC) - - For all determinations, the laboratory must analyze the IPC (a midrange check standard) and a calibration blank immediately following daily calibration, after every tenth sample (or more frequently, if required) and at the end of the sample run. Analysis of the IPC solution and calibration blank immediately following calibration must verify that the instrument is within $\pm 10\%$ of calibration. Subsequent analyses of the IPC solution must verify the calibration is still within $\pm 10\%$. If the calibration cannot be verified within the specified limits, reanalyze the IPC solution. If the second analysis of the IPC solution confirms calibration to be outside the limits, sample analysis must be discontinued, the cause determined and/or in the case of drift the instrument recalibrated. All samples following the last acceptable IPC solution must be reanalyzed. The analysis data of the calibration blank and IPC solution must be kept on file with the sample analyses data. NOTE: Secondary calibration standards (SS) may also be used as the IPC.
- 9.3.3 Where additional reference materials such as Performance Evaluation samples are available, they should be analyzed to provide additional performance data. The analysis of reference samples is a valuable tool for demonstrating the ability to perform the method acceptably.

10.0 CALIBRATION AND STANDARDIZATION

- 10.1 Turbidimeter calibration: The manufacturer's operating instructions should be followed. Measure standards on the turbidimeter covering the range of interest. If the instrument is already calibrated in standard turbidity units, this procedure will check the accuracy of the calibration scales. At least one standard should be run in each instrument range to be used. Some instruments permit adjustments of sensitivity so that scale values will correspond to turbidities. Solid standards, such as those made of lucite blocks, should never be used due to potential calibration changes caused by surface scratches. If a pre-calibrated scale is not supplied, calibration curves should be prepared for each range of the instrument.

11.0 PROCEDURE

- 11.1 Turbidities less than 40 units: If possible, allow samples to come to room temperature before analysis. Mix the sample to thoroughly disperse the solids. Wait until air bubbles disappear, then pour the sample into the turbidimeter tube. Read the turbidity directly from the instrument scale or from the appropriate calibration curve.
- 11.2 Turbidities exceeding 40 units: Dilute the sample with one or more volumes of turbidity-free water until the turbidity falls below 40 units. The turbidity of the original sample is then computed from the turbidity of the diluted sample and the dilution factor. For example, if 5 volumes of turbidity-free water were added to 1 volume of sample, and the diluted sample showed a turbidity of 30 units, then the turbidity of the original sample was 180 units.
- 11.2.1 Some turbidimeters are equipped with several separate scales. The higher scales are to be used only as indicators of required dilution volumes to reduce readings to less than 40 NTU.

NOTE 1: Comparative work performed in the Environmental Monitoring Systems Laboratory B Cincinnati (EMSL-Cincinnati) indicates a progressive error on sample turbidities in excess of 40 units.

12.0 DATA ANALYSIS AND CALCULATIONS

- 12.1 Multiply sample readings by appropriate dilution to obtain final reading.
- 12.2 Report results as follows:

NTU	Record to Nearest
0.0 – 1.0	0.05
1 – 10	0.1
10 – 40	1
40 – 100	5
100 – 400	10
400 – 1,000	50
> 1,000	100

13.0 METHOD PERFORMANCE

- 13.1 In a single laboratory (EMSL-Cincinnati), using surface water samples at levels of 26, 41, 75 and 180 NTU, the standard deviations were " 0.60, " 0.94, " 1.2 and " 4.7 units, respectively.
- 13.2 The interlaboratory precision and accuracy data in Table 1 were developed using a reagent water matrix. Values are in NTU.

14.0 POLLUTION PREVENTION

- 14.1 Pollution prevention encompasses any technique that reduces or eliminates the quantity or toxicity of waste at the point of generation. Numerous opportunities for pollution prevention exist in laboratory operation. The EPA has established a preferred hierarchy of environmental management techniques that places pollution prevention as the management option of first choice. Whenever feasible, laboratory personnel should use pollution prevention techniques to address their waste generation. When wastes cannot be feasibly reduced at the source, the Agency recommends recycling as the next best option.
- 14.2 The quantity of chemicals purchased should be based on expected usage during its shelf life and disposal cost of unused material. Actual reagent preparation volumes should reflect anticipated usage and reagent stability.
- 14.3 For information about pollution prevention that may be applicable to laboratories and research institutions, consult "Less is Better: Laboratory Chemical Management for Waste Reduction," available from the American Chemical Society's Department of Government Regulations and Science Policy, 1155 16th Street, N.W., Washington, DC 20036, (202) 872-4477.

15.0 WASTE MANAGEMENT

15.1 The U.S. Environmental Protection Agency requires that laboratory waste management practices be conducted consistent with all applicable rules and regulations. Excess reagents, samples and method process wastes should be characterized and disposed of in an acceptable manner. The Agency urges laboratories to protect the air, water and land by minimizing and controlling all releases from hoods, and bench operations, complying with the letter and spirit of any waste discharge permit and regulations, and by complying with all solid and hazardous waste regulations, particularly the hazardous waste identification rules and land disposal restrictions. For further information on waste management consult the "Waste Management Manual for Laboratory Personnel," available from the American Chemical Society at the address listed in Sect. 14.3.

16.0 REFERENCES

1. American Society for Testing and Materials (ASTM). 1993. *Annual Book of ASTM Standards, Volume 11.01*. Water (1), Standard D1889-88A, p. 359. West Conshohocken, PA,
2. Standard Methods. 1992. *Standard Methods for the Examination of Water and Wastewater*. Eighteenth Edition, pp. 2-9, Method 2130B. APHA, AWWA, and WEF. Port City Press, Baltimore, MD.

17.0 TABLES, DIAGRAMS, FLOWCHARTS AND VALIDATION DATA

Table 1. Interlaboratory Precision And Accuracy Data

Number of Values Reported	True Value (T)	Mean (X)	Residual for X	Standard Deviation (S)	Residual for S
373	0.450	0.4864	0.0027	0.1071	-0.0078
374	0.600	0.6026	-0.0244	0.1048	-0.0211
289	0.65	0.6931	0.0183	0.1301	0.0005
482	0.910	0.9244	0.0013	0.2512	0.1024
484	0.910	0.9919	0.0688	0.1486	-0.0002
489	1.00	0.9405	-0.0686	0.1318	-0.0236
640	1.36	1.3456	-0.0074	0.1894	0.0075
487	3.40	3.2616	-0.0401	0.3219	-0.0103
288	4.8	4.5684	-0.0706	0.3776	-0.0577
714	5.60	5.6984	0.2952	0.4411	-0.0531

641 5.95 5.6026 -0.1350 0.4122 -0.1078

Regressions: $X = 0.955T + 0.54$, $S = 0.074T + 0.082$

Test:				Date:				Operator:		
Sample Source: <input type="checkbox"/> Standard Solution ()NTU <input type="checkbox"/> Plant Water								Reviewed by:		
Calibration Check				Before Test				After Test		
Reference Turbidimeter 1 (Model #)				Time:		Reading:		Time:		Reading:
Reference Turbidimeter 2 (Model #)				Time:		Reading:		Time:		Reading:
Sample	Time of Sample Collection	Reference Turb. 1 (Model #)	Time of Sample Analysis	Reference Turb. 2 (Model #)	Time of Sample Analysis	pH	Color	Turbidimeter	Sample Port	Water Flow (gpm)
1									1	
2									2	
3									3	
4									4	
5									5	
Water Temperature:					Time of pH Meter Calibration:					
Room Temperature - Recirculation system:					Time of pH Meter Check:					
Room Temperature - Reference Turbidimeters:					pH Reading: _____ pH 4 Buffer _____ pH 7 Buffer					
Maintenance Needed:					Performance comments:					