

US EPA ARCHIVE DOCUMENT

# TECHNICAL RESOURCE DOCUMENT

## EXTRACTION AND BENEFICIATION OF ORES AND MINERALS

### VOLUME 6

# GOLD PLACERS

October 1994

U.S. Environmental Protection Agency  
Office of Solid Waste  
Special Waste Branch  
401 M Street, SW  
Washington, DC 20460



## **DISCLAIMER AND ACKNOWLEDGEMENTS**

This document was prepared by the U.S. Environmental Protection Agency (EPA). The mention of company or product names is not to be considered an endorsement by the U.S. Government or by EPA.

This Technical Resource Document consists of three sections. The first is EPA's Profile of the gold placer mining industry; the following sections are reports on site visits conducted by EPA to gold placer mines in Alaska. The Profile section was distributed for review to the U.S. Department of the Interior's Bureau of Mines, the State of Alaska Department of Natural Resources and Department of Environmental Conservation, the Interstate Mining Compact Commission, the American Mining Congress, the Mineral Policy Center, and public interest groups. Summaries of the comments received on the draft profile and of EPA's responses are presented as an appendix to this section. The site visit sections were provided to representatives of the companies and of state agencies who participated in the site visit. Their comments and EPA's responses are presented as appendices to the specific site visit section. EPA is grateful to all individuals who took the time to review sections of this Technical Resource Document.

The use of the terms "extraction," "beneficiation," and "mineral processing" in this document is not intended to classify any waste stream for the purposes of regulatory interpretation or application. Rather, these terms are used in the context of common industry terminology.

TABLE OF CONTENTS

|   | <u>Page</u> |
|---|-------------|
| 1.0 MINING INDUSTRY PROFILE: GOLD PLACERS .....                   | 1-1         |
| 1.1 INTRODUCTION .....  | 1-1         |
| 1.2 ECONOMIC CHARACTERIZATION OF THE GOLD PLACER INDUSTRY .....   | 1-2         |
| 1.2.1 Background .....  | 1-2         |
| 1.2.2 Current Operations .....                                    | 1-3         |
| 1.3 PHYSICAL CHARACTERIZATION OF PLACER DEPOSITS .....            | 1-6         |
| 1.4 GOLD PLACER MINING PRACTICES .....                            | 1-10        |
| 1.4.1 Background .....  | 1-10        |
| 1.4.2 Extraction Methods .....                                    | 1-11        |
| 1.4.2.1 Open Cut Methods .....                                    | 1-13        |
| 1.4.2.2 Other Methods .....                                       | 1-14        |
| 1.4.3 Beneficiation Methods .....                                 | 1-18        |
| 1.4.3.1 Sizing .....  | 1-19        |
| 1.4.3.2 Coarse Concentration .....                                | 1-21        |
| 1.4.3.3 Fine Concentration .....                                  | 1-22        |
| 1.4.3.4 Mercury Amalgamation .....                                | 1-26        |
| 1.5 WASTE MANAGEMENT PRACTICES .....                              | 1-26        |
| 1.5.1 Extraction and Beneficiation Wastes and Materials .....     | 1-26        |
| 1.5.1.1 Waste Rock or Overburden .....                            | 1-27        |
| 1.5.1.2 Tailings .....  | 1-27        |
| 1.5.2 Waste and Materials Management .....                        | 1-28        |
| 1.5.2.1 Tailings Impoundments/Settling Pond Systems .....         | 1-29        |
| 1.6 ENVIRONMENTAL EFFECTS .....                                   | 1-38        |
| 1.6.1 Surface Water .....   | 1-39        |
| 1.6.2 Ground Water .....  | 1-41        |
| 1.6.3 Soil .....  | 1-41        |
| 1.6.4 Wetlands .....  | 1-41        |
| 1.6.5 Wildlife .....  | 1-41        |
| 1.7 MITIGATING MEASURES AND REMEDIATION .....                     | 1-43        |
| 1.7.1 Tailings .....  | 1-43        |
| 1.7.2 Stream Channel .....  | 1-43        |
| 1.7.3 Floodplain .....  | 1-44        |
| 1.7.4 Soils .....   | 1-45        |
| 1.7.5 Mined Land Remediation .....                                | 1-46        |
| 1.8 CURRENT REGULATORY AND STATUTORY FRAMEWORK .....              | 1-47        |
| 1.8.1 Environmental Protection Agency Regulations .....           | 1-47        |
| 1.8.1.1 Resource Conservation and Recovery Act .....              | 1-47        |
| 1.8.1.2 Clean Water Act .....                                     | 1-48        |
| 1.8.1.3 Dredged and Fill Material .....                           | 1-49        |
| 1.8.2 Department of the Interior .....                            | 1-51        |
| 1.8.2.1 Bureau of Land Management .....                           | 1-51        |
| 1.8.2.2 National Park Service and Fish and Wildlife Service ..... | 1-52        |
| 1.8.3 Department of Agriculture (Forest Service) .....            | 1-53        |
| 1.8.4 State Programs .....  | 1-53        |
| 1.8.4.1 Alaska .....  | 1-53        |
| 1.8.4.2 Colorado .....  | 1-56        |
| 1.9 REFERENCES .....  | 1-59        |

|         |  |      |
|---------|--|------|
| 2.0     | SITE VISIT REPORTS: ALASKA PLACER MINES                          | 2-1  |
| 2.1     | INTRODUCTION   | 2-1  |
| 2.2     | POLAR MINING, INC.   | 2-1  |
| 2.2.1   | General Facility Description                                     | 2-1  |
| 2.2.2   | Regulatory Requirements and Compliance                           | 2-9  |
| 2.3     | ALF HOPEN  | 2-11 |
| 2.3.1   | General Facility Description                                     | 2-11 |
| 2.3.2   | Regulatory Requirements and Compliance                           | 2-13 |
| 2.4     | COOK'S MINING  | 2-14 |
| 2.4.1   | General Facility Description                                     | 2-14 |
| 2.4.2   | Regulatory Requirements and Compliance                           | 2-16 |
| 2.5     | REFERENCES   | 2-17 |
| 3.0     | SITE VISIT REPORT: VALDEZ CREEK MINE CAMBIOR ALASKA INCORPORATED | 3-1  |
| 3.1     | INTRODUCTION   | 3-1  |
| 3.1.1   | Background   | 3-1  |
| 3.1.1.1 | General Description  | 3-2  |
| 3.1.2   | Environmental Setting  | 3-7  |
| 3.1.2.1 | Geology  | 3-7  |
| 3.1.2.2 | Surface Water  | 3-10 |
| 3.1.2.3 | Ground Water   | 3-10 |
| 3.2     | FACILITY OPERATION   | 3-11 |
| 3.2.1   | General Overview   | 3-11 |
| 3.2.2   | Extraction   | 3-11 |
| 3.2.2.1 | Excavation   | 3-12 |
| 3.2.2.2 | Water Management   | 3-14 |
| 3.2.3   | Beneficiation  | 3-15 |
| 3.2.3.1 | Ancillary Facilities   | 3-18 |
| 3.3     | MATERIALS AND WASTE MANAGEMENT                                   | 3-18 |
| 3.3.1   | Waste Rock   | 3-18 |
| 3.3.2   | Tailings   | 3-18 |
| 3.3.3   | Other Materials  | 3-23 |
| 3.4     | REGULATORY REQUIREMENTS AND COMPLIANCE                           | 3-26 |
| 3.4.1   | Federal Permits  | 3-26 |
| 3.4.1.1 | Bureau of Land Management  | 3-26 |
| 3.4.1.2 | Army Corp of Engineers   | 3-26 |
| 3.4.1.3 | Environmental Protection Agency                                  | 3-26 |
| 3.4.2   | State Permits  | 3-27 |
| 3.4.2.1 | Dam Safety   | 3-27 |
| 3.4.2.2 | Diversion Channel  | 3-28 |
| 3.4.2.3 | Alaska Fish and Game   | 3-28 |
| 3.4.2.4 | Solid Waste Permit   | 3-28 |
| 3.4.3   | Inspections and Compliance Incidents                             | 3-29 |
| 3.4.3.1 | Inspections  | 3-29 |
| 3.4.3.2 | Compliance Incidents   | 3-30 |
| 3.5     | REFERENCES   | 3-31 |

**APPENDICES**

APPENDIX 1-A **ACRONYMS** ..... 1-65

APPENDIX 1-B **COMMENTS SUBMITTED BY U.S. BUREAU OF MINES ON DRAFT GOLD PLACER PROFILE** ..... 1-68

APPENDIX 1-C **RESPONSE TO COMMENTS SUBMITTED BY U.S. BUREAU OF MINES ON DRAFT GOLD PLACER PROFILE REPORT** ..... 1-70

APPENDIX 3-A **COMMENTS SUBMITTED BY CAMBIOR ALASKA INC., ON DRAFT SITE VISIT REPORT** ..... 3-33

APPENDIX 3-B **EPA RESPONSE TO COMMENTS SUBMITTED BY CAMBIOR ALASKA INCORPORATED ON DRAFT SITE VISIT REPORT** ..... 3-34

APPENDIX 3-C **COMMENTS SUBMITTED BY THE STATE OF ALASKA ON DRAFT SITE VISIT REPORT** ..... 3-36

APPENDIX 3-D **EPA RESPONSE TO COMMENTS SUBMITTED BY THE STATE OF ALASKA ON DRAFT SITE VISIT REPORT** ..... 3-37

**LIST OF TABLES**

**Page**

Table 1-1. **EPA and Bureau of Mines Estimates of Operational Placer Mines** ..... 1-5

Table 1-2. **Turbidity and Arsenic Levels in Two Alaskan Creeks** ..... 1-40

Table 3-1. **Estimated Volumes of Overburden and Pay-Gravel** ..... 3-13

Table 3-2. **Theoretical Efficiency of Settling Ponds** ..... 3-20

Table 3-3. **NPDES Discharge Rates** ..... 3-22

Table 3-4. **Storage Tank Summary** ..... 3-25

LIST OF FIGURES

|  | <u>Page</u> |
|--|-------------|
| Figure 1-1. Overview of a Placer Mining Operation .....                              | 1-13        |
| Figure 1-2. Long Tom .....   | 1-16        |
| Figure 1-3. Basic Design for a Prospector's Rocker .....                             | 1-17        |
| Figure 1-4. Diagram of a Trommel .....   | 1-20        |
| Figure 1-5. Diagram of a Sluice Box Including Hungarian Riffles .....                | 1-21        |
| Figure 1-6. Diagram of a Jig .....   | 1-23        |
| Figure 1-7. Diagram of a Centrifugal Bowl .....                                      | 1-24        |
| Figure 1-8. Diagram of a Pinched Sluice .....  | 1-25        |
| Figure 1-9. Pre-Settling Ponds .....   | 1-31        |
| Figure 1-10. Sediment Removal Before Ponds by Filtration .....                       | 1-33        |
| Figure 1-11. Settling Ponds with Tailings Filters .....                              | 1-35        |
| Figure 1-12. Settling/Recycle Pond .....   | 1-37        |
| <br>   |             |
| Figure 2-1. Polar Mining, Inc., Vicinity Map .....                                   | 2-2         |
| Figure 2-2. Sketch of Lower Goldstream Creek Mining Operation .....                  | 2-4         |
| Figure 2-3. Plan View of Lower Goldstream Creek Operation, Amended 1992 .....        | 2-6         |
| Figure 2-4. Second Plan View of Lower Goldstream Creek Operation, Amended 1992 ..... | 2-7         |
| <br>   |             |
| Figure 3-1. Facility Location Map .....  | 3-3         |
| Figure 3-2. Denali Mine Work Areas .....   | 3-5         |
| Figure 3-3. Typical Cross Section of Pits A-6 Through A-10 .....                     | 3-9         |
| Figure 3-4. Water Balance for 1990 Through 1991 .....                                | 3-17        |

## 1.0 MINING INDUSTRY PROFILE: GOLD PLACERS

### 1.1 INTRODUCTION

This Industry Profile presents the results of U.S. Environmental Protection Agency (EPA) research into the domestic gold placer mining industry and is one of a series of profiles of major mining sectors. Additional profiles describe lode gold mining, lead/zinc mining, copper mining, iron mining, and several industrial mineral sectors, as presented in the current literature. EPA prepared these profiles to enhance and update its understanding of the mining industry and to support mining program development by states. EPA believes the profiles represent current environmental management practices as described in the literature.

Each profile addresses extraction and beneficiation of ores. The scope of the Resource Conservation and Recovery Act (RCRA) as it applies to mining waste was amended in 1980 when Congress passed the Bevill Amendment, Section 3001(b)(3)(A). The Bevill amendment states that "solid waste from the extraction, beneficiation, and processing of ores and minerals" is excluded from the definition of hazardous waste under Subtitle C of RCRA (40 CFR 261.4(b)(7)). The exemption was conditional upon EPA's completion of studies required by RCRA Section 8002(f) and (p) on the environmental and health consequences of the disposal and use of these wastes. EPA segregated extraction and beneficiation wastes from processing wastes. EPA submitted the initial results of these studies in the 1985 *Report to Congress: Wastes from the Extraction and Beneficiation of Metallic Ores, Phosphate Rock, Asbestos, Overburden From Uranium Mining, and Oil Shale* (U.S. EPA 1985a). In July 1986, EPA made a regulatory determination that regulation of extraction and beneficiation wastes under Subtitle C was not warranted (51 FR 24496; July 3, 1986). EPA concluded that Subtitle C controls were unnecessary and found that a wide variety of existing Federal and State programs already addressed many of the risks posed by extraction and beneficiation wastes. Instead of regulating extraction and beneficiation wastes as hazardous wastes under Subtitle C, EPA indicated that these wastes should be controlled under Subtitle D of RCRA.

EPA reported their initial findings on wastes from mineral processing from the studies required by the Bevill Amendment in the 1990 *Report to Congress: Special Wastes From Mineral Processing* (U.S. EPA 1990). This report covered 20 specific mineral processing wastes; none involved gold processing wastes. In June 1991, EPA issued a regulatory determination (56 FR 27300) stating that regulation of these 20 mineral processing wastes as hazardous wastes under RCRA Subtitle C is inappropriate or infeasible. These 20 wastes are subject to applicable state requirements. Any mineral processing wastes not specifically included in this list of 20 wastes no longer qualifies for the exclusion (54 FR 36592). Due to the timing of this decision and the limited number of industry wastes at issue, gold placer processing wastes are not addressed in this profile.

In addition to preparing profiles, EPA has undertaken a variety of activities to support state mine waste programs. These activities include visits to a number of mine sites; compilation of data from State regulatory



agencies on waste characteristics, releases, and environmental effects; preparing summaries of mining-related sites on the National Priorities List (NPL); and an examination of specific waste management practices and technologies. EPA has also conducted studies of State mining-related regulatory programs and their implementation.

The purpose of this profile is to provide additional information on the domestic gold placer mining industry. The report describes gold placer extraction and beneficiation operations with specific reference to the wastes associated with these operations. The report is based on literature reviews. This report complements, but was developed independently of, other Agency activities, including those described above.

This report briefly characterizes the geology of gold placer deposits and the economics of the industry. Following this discussion is a review of gold placer extraction and beneficiation methods; this section provides the context for descriptions of wastes and materials managed by the industry, as well as a discussion of the potential environmental effects that may result from gold placer mining. The profile concludes with a description of the current regulatory programs that apply to the gold placer mining industry as implemented by EPA, Federal land management agencies, and selected States. The profile section is followed by reports on site visits conducted by EPA to gold placer mines in Alaska.

## **1.2 ECONOMIC CHARACTERIZATION OF THE GOLD PLACER INDUSTRY**

### **1.2.1 Background**

Placer gold is typically sold in one of two forms. Nuggets may be sold to jewelry makers, the general public, or other users directly. An unknown amount of gold production enters the market directly by sales to the jewelry industry, and thus, may never be reported as typical production from some small operations. Individual pieces are typically assessed an additional charge or "nugget bonus" in addition to the gold market price. Placer gold may also be smelted, and pass into the market through the same route as lode-mined gold (U.S. EPA 1988b).

Gold mining began in the United States in the early 1800s in North Carolina and soon followed in Georgia and Alabama in 1829 and 1830, respectively. Although not a state until 1850, gold mining was also conducted in California as early as the late 1700s. California was not a major gold producer until the gold rush began with the discovery of gold at Sutter's Mill in 1848. As gold prospectors moved west, mining also commenced in other states. Production in California between 1850 and 1864 averaged nearly 2.45 million troy ounces annually. After the rich, readily accessible placer deposits were mined out, gold was extracted using drift mining techniques and later, hydraulic methods. Hydraulic methods were limited after 1884. In the late 1890s, dredges were employed to mine alluvial placers, a practice that continued steadily through the 1960s, and intermittently through the 1980s (Clark 1970; Silva 1986).

Placer gold deposits were known to exist in Alaska prior to its purchase by the United States in 1867, but these deposits were not exploited until California gold rush prospectors eventually commenced operations in

Alaska as they moved up the coast. By 1940 Alaska led the states in gold production, supplying 750,000 troy ounces of gold, mostly from placer mines. During World War II, domestic placer mining activity subsided substantially and remained at a low level after the war because of rising operating costs and a government-fixed gold price of \$35 per troy ounce. When the federal restrictions on prices and private ownership of gold were relaxed and the market price of gold increased in the late 1970s, there was a resurgence in gold mining activity including placers (U.S. EPA 1988a).

During the 1800s, and early into this century, gold mining of alluvial deposits primarily involved placer methods. Miners worked stream deposits using a variety of techniques and recovered gold by gravity separation and mercury amalgamation. In Alaska, mining quickly exhausted the high-grade gold deposits, but the introduction of new extraction techniques made it possible for miners to successfully access lower-grade deposits, as well as to increase the overall productivity of placer mining. Large-scale permafrost thawing, hydraulic stripping, and mechanized excavation methods were some of the innovative extraction techniques that modernized the industry. In 1905, mechanical dredges reached Nome, Alaska, and in the 1920s, mining operations in the same region began to work with large electric-powered dredges (U.S. EPA 1988a).

Gold recovery methods and efficiency have continued to evolve over the years with the refinement of techniques, equipment and technology. Before the 1940s, miners were able to recover up to 60% of the gold values within a deposit. By 1945, recovery rates were between 70 and 75 percent. Currently, miners interviewed during EPA's recent site visits claimed that, depending on the type of operation, over 90 percent of gold may be recovered from a deposit. As efficiency has gone up, so has the difficulty level in extracting the remaining deposits (Silva 1986).

### **1.2.2 Current Operations**

According to U.S. Bureau of Mines statistics, placer mines have historically produced approximately 35 percent of the total U.S. gold production. However, while net gold production has increased annually in recent years, placer production has decreased as the readily accessible deposits have been mined out and with the increase and improvement in heap leaching technology. Placer mines produced only two to three percent of the total U.S. gold production during the period from 1984 through 1989; in 1990 and 1991, placer production accounted for approximately one percent of the U.S. total. According to Bureau of Mines statistics, placer mines produced 2,888 kg of gold in 1991 while total U.S. gold production was approximately 289,885 kg (U.S. DOI, Bureau of Mines 1988a; U.S. DOI, Bureau of Mines 1992a; Lucas 1992).

The economics involved in mining a deposit is dependant on factors including the cost of fuel, interest rates, and the market price of gold. These factors are variable in terms of location and time. Under 1991 conditions, gold placer mines could economically beneficiate gravels containing as little as 0.49 grams per cubic meter (0.01 oz/cubic yard). However, average recoverable gold content of precious metals from placer gravels was 0.82 gm/m<sup>3</sup> (0.02 oz/yd<sup>3</sup>) of material washed. (U.S. DOI, Bureau of Mines 1992a).

The size and nature of placer mines range from open cut operations disturbing tens of acres annually to small sluices operated solely as a recreational activity. In 1987, the average number of employees at placer mines in the contiguous 48 states was between three and four, and few mines employed more than 10 people (U.S. EPA 1988b). The size of a placer mining operation determines whether or not it is subject to compliance with the Clean Water Act administered by the Environmental Protection Agency (EPA) under 40 CFR 440 Subpart M. Mines handling less than 1,500 cubic yards of ore per year and dredges handling less than 50,000 cubic yards annually are exempted from the effluent guidelines (40 CFR, Part 440, Subpart M 1989). A more complete discussion of regulatory issues is presented in the current regulatory framework section of this report.

Regardless of size, most placer mines throughout the country operate on a seasonal basis (ADEC 1986; U.S. EPA 1988a). The small size of most placer operations and the relative ease in establishing an operation make placer mines particularly sensitive to fluctuations in market prices; more mines are active when prices are up and fewer are active as prices drop. These facts contribute to the difficulty in establishing the number of mines operating at any one point in time (U.S. EPA 1988a). Additionally, the limited information collected by state and federal agencies, and the sources that these agencies use to determine the number of operational mines, make specific characterization of the placer mining industry exceedingly difficult.

Alaska has the highest concentration of operational placer mines and is the only state where gold production from placer operations exceeds that from lode operations. In 1991, according to the Alaska Department of Natural Resources, Alaskan mines (202 placer and 2 hard rock mines) produced 7,585 kg of gold. Production from placer and hard rock mines was not differentiated. The number of placer mines operating in 1991 dropped to 202 from the 218 reported in 1990. Low gold prices, exhaustion of resources and increasing regulatory requirements were cited as reasons for the decrease. The 202 placer mines operating in Alaska in 1991 employed 1,240 people, although this number is adjusted for a 260 day work-year (Alaska Department of Natural Resources 1992b). Half of the placer gold produced in Alaska in recent years comes from just two mines; Valdez Creek mine and Green's Creek mine. The remaining 200 mines produce an average of 500 ounces per year. The average grade is .0158 ounces per yard, so that the average in-place value of Alaskan pay gravels is just over \$5.00 a yard or about \$3.00 per ton. Stripping overburden costs between \$1 and \$2 a yard at most mines, depending on site specific conditions. The low grade of placer ores is the reason the placer industry is a small business or family oriented industry. Major mining companies with high capitalization costs can not operate placer ground at a profit (Peterson 1993).

The Bureau of Mines also collects and publishes data based on results collected from a voluntary survey. Data collected during the 1988 survey showed that placer mines operated in a number of states including Alaska, Idaho, Montana and Nevada (U.S. DOI, Bureau of Mines 1989a; U.S. DOI, U.S. DOI, Bureau of Mines 1989b; U.S. DOI, Bureau of Mines 1989c; U.S. DOI, Bureau of Mines 1989d). Placer mines have also operated in Oregon on at least a limited basis (U.S. DOI, Bureau of Mines 1992a).

Data from a previous survey (U.S. EPA 1985b) indicated that there were four operating placer mines in Colorado; 29 in Idaho (mostly seasonal); one in California (processing  $4.5 \times 10^6$  ton/year) and 46 in Montana (most probably seasonal or intermittent). These were based upon state agency records and permit files.

Bureau of Mines publications typically withhold figures for placer production by state to protect proprietary information and do not provide specific lists of gold placer mines. Of the 19 placer operations that responded in 1991, 14 were considered in the underground, small-scale mechanical and hand methods or suction dredge category. The other four were bucketline dredging operations (U.S. DOI, Bureau of Mines 1992a). A 1986 survey conducted by the EPA, based on data collected from state agencies, showed a total of 454 placer mines in operation (U.S. EPA 1988b). The same year, the Bureau of Mines reported 207+ operational placer mines (U.S. DOI, Bureau of Mines 1986). The number of placer mines operating in each state in 1986, as tabulated by EPA and the Bureau of Mines, is presented in Table 1-1.

**Table 1-1. EPA and Bureau of Mines Estimates of Operational Placer Mines**

| State        | EPA Estimate <sup>1</sup> | Bureau of Mines Estimate <sup>2</sup> |
|--------------|---------------------------|---------------------------------------|
| Alaska       | 190                       | 195                                   |
| Idaho        | 69                        | 2                                     |
| Montana      | 57                        | 6                                     |
| California   | 26                        | 2                                     |
| Colorado     | 13                        | 0                                     |
| Oregon       | 49                        | Several                               |
| South Dakota | 18                        | 0                                     |
| Wyoming      | 8                         | 0                                     |
| Washington   | 16                        | 1                                     |
| Utah         | 5                         | 0                                     |
| Nevada       | 3                         | 1                                     |
| TOTAL        | 454                       | 207+                                  |

<sup>1</sup> (U.S. EPA 1988b).

<sup>2</sup> (U.S. DOI, Bureau of Mines 1986).

### 1.3 PHYSICAL CHARACTERIZATION OF PLACER DEPOSITS

Placer deposits are mineral bearing deposits found in weathered residuum and alluvium. The word placer is of Spanish derivation, used by early miners in North and South America to describe the gold found in gravels and sands associated with streams. For the most part, placers are unconsolidated sedimentary deposits, although, depending on the nature of the associated materials, placers may be cemented to varying degrees. Placers occurring within permafrost are usually frozen solid (Boyle 1979). Current placer mining activity generally takes place in young placers originating as waterworked sediments or stream deposits.

There are several natural requirements necessary before a placer deposit can form: there must be a valuable mineral which is relatively heavy and resistant to weathering and abrasion; the valuable mineral must be released from its parent rock; and the valuable mineral must be concentrated into a workable deposit (usually by water transport). Although the location, size, and shape of a placer will reflect the regional forces of erosion, transportation, and deposition which created it, its final form will be controlled or modified by purely local conditions. As a result, each placer deposit can be expected to be unique in one or more ways. The end richness and size of a placer deposit will depend more on there being an abundant supply of source materials, and on conditions favorable for their concentration, than on the actual richness of the primary source. (Wells 1973)

Gold particles in placer deposits range in size from 'flour' gold (-400 mesh) found in Idaho's Snake River, to the massive, 2516 troy ounce 'Welcome Stranger' nugget found in Victoria, Australia. Although the value of a placer deposit is generally based on smaller particles (called colors), nuggets are the perceived rewards for a miner's toils and are associated with placers. Nugget formation is not fully understood: some are larger remnants of lode deposits that have become part of a placer deposit, while others apparently form in place within streams where dissolved gold precipitates on either a gold particle or other nucleus. Although nugget formation may occur within streams, placer gold often has a platy (i.e., tabular) form (Boyle 1979; MacDonald 1983).

The density of gold, and its resistance to chemical weathering, are two principal factors for the development of gold placer deposits. Gold is considerably more dense than the minerals typically associated with it (19.3 grams per cubic centimeter [g/cc] versus 2.65 g/cc for quartz). Heavy minerals typically settle to the bottom of a stream or beach displacing lighter material. Gold continues a downward migration in response to additional agitation within the streambed. Settling action also occurs on land in colluvium although the downward migration is not as pronounced as the absence of a fluid matrix. Placer deposits are formed as particles accumulate in this manner (Park and MacDiarmid 1975).

The distance gold particles move within a stream (or by gravity) is dependant on the size and shape of the particle, and the energy of the stream. Large particles will settle close to their source while the smallest may travel great distances. Particles are often deposited in riffles and other irregularities within the streambed where the energy and velocity of the stream are reduced (Park and MacDiarmid 1975).

Particles that are carried great distances in streams are typically more pure than the lode deposits from which they came. The increase in purity is a result, in part, of the dissolution of impurities within the gold particle (Boyle 1979). It has also been observed that the oxidized portion of lode deposits, (that which is also most likely to become placer gold), is often of greater purity than the primary deposit. Fineness is a measure of purity in gold with 1.000 being absolutely pure. Gold in placers ranges from 0.500 to 0.999 fine; most is greater than 0.850 fine (Boyle 1979).

Placer gold is different in appearance than gold deposited in veins. Crystallization on the surface of placer particles dull the luster normally associated with vein deposits. Placer deposits may be colored brown or black if coated with manganese and iron oxides or manganese and iron humates; or white to gray when coated with calcium carbonate or colloidal clay (Boyle 1979).

The terms pay streak, pay dirt and pay gravel refer to the zone where the economic concentration of gold is located. The pay zone is often found in the layer adjacent to the bedrock, but under certain conditions the pay zone may be located on the surface or in one or more intermediate layers (Wells 1973). Finer gold particles are carried farther from their source and have a greater tendency to be distributed throughout the sediments in which they are found. The value of the pay streak is usually assessed as troy ounces per cubic yard, and varies throughout the deposit (Boyle 1979).

Placers exist in different forms although they all originate from lode deposits. Placer deposits may be young (modern) or ancient (fossil). Young deposits are usually found along present day water courses and were formed during the Quaternary (Recent and Pleistocene Epochs) and late Tertiary Periods. Young deposits range from a few feet to more than 10 feet in thickness (U.S. EPA 1988a). Ancient deposits occur in paleochannels and are usually buried by layers of sediment or volcanics. In the Sierra Madre of California, lava that filled ancient stream channels now forms residual ridges as material adjacent to the lava has been eroded away (Park and MacDiarmid 1975). Some of these rich fossil placers have been identified in tertiary gravels buried beneath up to 1,500 feet of sediment (Hatkoff 1983). Ancient deposits in Alaska may be 10 to 40 feet thick, buried under 10 to 30 feet of humus, sand, silt and clay (U.S. EPA 1988a). Other ancient placers have been located in northwestern Wyoming and the Deadwood formation of South Dakota. Ancient placers in the contiguous 48 states are not typically mined since expensive underground mining techniques are often required (Boyle 1979).

Alluvial placers form when material is concentrated in stream channels. For this reason they are also referred to as stream or fluvial placers. Alluvial placers were likely to have been man's first source of gold. It is speculated that sheepskins may have been placed in streams to trap gold bearing sediments, adding new insight to the myth of Jason's golden fleece (Boyle 1979). Alluvial placers are formed in sedimentary deposits as gold is picked up where currents are fast and deposited where the stream velocity slows. Alluvial deposits are not restricted to channels and may be deposited at the mouths of streams and rivers. Most significant placer deposits in the U.S. are of alluvial origin including those in the Sierra Nevada region of California (Boyle 1979).

Alluvial gold placers are associated with a wide range of minerals depending on the geology of the lode deposits from where they came. The gold, or electrum, may be naturally alloyed with other metals such as copper, iron, lead, silver and zinc. In addition, minerals containing varying concentrations of copper, iron, lead, silver and zinc have been found with gold placer deposits as have monazite, pyrite, arsenopyrite and wolframite. 'Black sands', associated with placer deposits in many areas, consist of heavy minerals including magnetite, ilmenite and members of the garnet group (ADEC 1986; Ferguson and Gavis 1972; Thompson 1992).

The characteristics of different alluvial or stream placers varies considerably, but generally they can be divided into several categories based on the size of the stream (Wells 1973). Gulch placers are characteristically small in area, have steep gradients and are confined to minor drainages in which a permanent stream may or may not exist. This type of placer is made up of poorly sorted gravel. Boulders are usually found in quantities that preclude all but simple hand mining methods. Creek placers are found in permanent streams and are composed of a mix of gravels, cobbles and boulders. Generally the size and number of boulders in creek placers is less than in gulch placers. Creek placers are important sources of gold. River placers are similar to creek placers but the gold is usually finer, the gravel well-rounded and large boulders few or absent. Over-all river placers are generally low-grade, but local pay streaks and bedrock concentrations may be able to support large-scale mining operations.

Alluvial placer deposits are currently the most economically significant in the U.S. and will be the focus of this profile. Other forms of placers, including flood gold, bench, beach, eluvial, desert, eolian, and glacial placers will also be discussed briefly below.

As a rule, finely-divided gold travels long distances under flood conditions. This gold, which can best be referred to by the miners' term of "flood gold," consists of extremely minute particles and is found far from its original source. Flood gold will be deposited near the surface of a sand bar between the high and low water mark on the inside bend of the stream. Good surface showings of fine-size gold are not uncommon, but often the gravel a few inches beneath these surface concentrations is nearly worthless. With few exceptions flood gold has proven economically unimportant in spite of its deceptively rich surface concentrations. However, such deposits may not be permanently exhausted by mining since floods deposit a new supply of gold and the renewal will continue indefinitely. In some cases small-scale mining operations are able to skim the new accumulations of flood gold from the same location year after year, however more ambitious plans to mine the deeper gravels have generally proved unprofitable. (Wells 1973)

Bench placers are usually remnants of deposits formed during an earlier stage of stream development and left behind as the stream cuts downward. The abandoned segments, particularly those on the hillsides, are commonly referred to as "bench" gravels. Frequently there are two or more sets of benches in which case the miners refer to them as "high" benches and "low" benches. Bench placers have been mined in the past using underground mining methods and following the development of hydraulic mining in the 1850s, many of the larger benches were worked by hydraulicking and the smaller ones by ground sluicing. (Wells 1973)

Beach placers are also formed by water action, but in this case gold is eroded by wave action from deposits along a shoreline or reworked from sediments carried to the sea by nearby rivers and deposited within the beach materials. Some beach placers are being, or have recently been, mined around Nome, Alaska, usually by dredging (Boyle 1979). Typical beach placers are found as erratically distributed, somewhat lenticular concentrations or streaks of black sand minerals with varying amounts of finely-divided gold. Those found along active beaches are the result of storm and tidal action, and they come and go with the changing conditions of the beach (Wells 1973). Beach placers may be either submerged or elevated due to sea level fluctuations of the past.

Eluvial placers have been referred to as residual deposits. The distinction between eluvial and other forms of placer deposits is that these deposits have been concentrated in place, as the lighter, valueless surrounding material has been leached or eroded away. Deposits formed on a slope as a result of gravity-driven downhill creep are included in the definition of eluvial deposits although these deposits may also be referred to as colluvial (Hatkoﬀ 1983; Macdonald 1983). Eluvial deposits were worked in the Appalachians of Georgia as well as in California, Oregon, Nevada and Montana (Boyle 1979; Hatkoﬀ 1983; Macdonald 1983). Considering the relative ease in mining these deposits, most of the economically significant deposits have been mined out.

Desert placers are so different from normal stream placers as to deserve a special classification. Desert placers are found in arid regions where erosion and transportation of debris depends largely on fast-rising streams that rush down gullies and dry washes following summer cloudbursts. During intervening periods, varying amounts of sand, gravel or hill-side detritus is carried in from the sides by lighter, intermittent rain wash which is sufficient to move material into the washes but not carry it further. When the next heavy rain comes, a torrential flow may sweep up all of the accumulated detrital fill, or only part of it, depending on intensity and duration of the storm and depth of fill. The intermittent flows provide scant opportunity for effective sorting of the gravels or concentration of the gold. Under such conditions the movement and concentration of placer gold will be extremely erratic. Moreover, where the entire bedload is not moved, any gold concentration resulting from a sudden water flow will be found at the bottom of the temporary channel existing at that time. This may be well above bedrock. As a result, gold concentrations, if present at all, may be found in one or more discrete lenses or layers scattered throughout the gully sediments and the best chance of finding pay gravel is to a great extent fortuitous and largely dependent on careful prospecting. (Wells 1973)

Eolian placers are also found in arid or desert regions, but where the wind acts as the agent of concentration. By blowing sand and the lighter rock particles away from a body of low-value material the wind may leave an enriched surface veneer containing gold in a somewhat concentrated state (Wells 1973). Eolian placers differ from most other placers in that the gold has been concentrated in place by the removal of other less valuable material rather than by being transported to a new location where it is concentrated and deposited. There is no reference to eolian placers being mined in the U.S. World-wide, the limited extent of these deposits generally does not warrant specific exploration or development (Macdonald 1983).



Glacial placers are deposited as a result of glacial activity. The nature of glacial movement, however, tends to mix materials to such an extent that without subsequent fluvial activity, mining is not an economically viable option. On the other hand, it is not unusual for a miner to assert that a particular deposit, particularly if its origin is obscure, is a "glacier" placer. Occasionally bits of rich but widely scattered float have been found in glacial moraines but because the gold is mixed with large masses of barren earth attempts to mine the moraines are rarely successful. One reference was made to the mining of a glacial placer near Fairplay, Colorado. Here the actual moraines were mined locally but the most extensive and productive placers were found in outwash aprons extending away from the true moraines. Where outwash aprons were mined, the glacial materials were reworked by running water and were not a true glacial placer, however since glacial rivers choke themselves and build up their channels progressively, their deposits are likely to be thicker and not so well concentrated as those of the more normal graded rivers which are not associated with glaciers. (Wells 1973)

## **1.4 GOLD PLACER MINING PRACTICES**

### **1.4.1 Background**

Typically a placer mine moves up-valley so that settling ponds and water runoff will be down gradient from the wash plant. Often the original stream is relocated to a temporary channel during the period of mining. In addition, the previously mined ground cannot be immediately reclaimed since it is necessary to maintain a drain below the operation. Miners have also found that it is almost impossible to control all of the water that comes into the mine from the side hills and the cut above the wash plant creating the potential for prolonged erosion and down-stream environmental impacts. Once the mine has ceased operations, the miner is then faced with the need to reclaim large tracts of stream valley with no more prospect of additional income from the property.

Recently two popular mining methods have been developed that make reclamation easier. One is the "Koppenberg" method in which the wash plant is highly portable. In this method, the wash plant is continuously moved to the pay dirt instead of the pay dirt being moved to the plant. In this method, the size of each mining cut is the length of the back-hoe arm that feeds the plant. No great mounds of tailings are generated because the tailings are backfilled into the previous hole as the plant moves along. This method works extremely well in narrow valleys but does not work well in frozen ground (Peterson 1993).

A second new method, effective in mining large open cut mines is to mine down-valley instead of the standard up-valley method. This means that the recycle pond and settling basin is up hill from the cut. The result is they can much more easily control the amount of water coming into and escaping from the operation, and they can reclaim the old cuts as they mine down-valley away from them. Since they are not needed to maintain an open drain, there is no reason for the open cuts to be left unreclaimed. A critical part of the reclamation plan is to plan for the position of the stream at the end of mining (Peterson 1993).

Gold placer mining consists of three major operational steps: extraction, beneficiation and processing. Extraction is defined as removing ore material from a deposit and encompasses all activities prior to beneficiation. Beneficiation is the operation by which gold particles are separated from the associated undesirable material. Beneficiation in placer mining usually involves gravity separation techniques. Processing operations, including smelting, produce a final, marketable product bullion from the gold concentrate produced in beneficiation. Most gold placer mining has been conducted using surface techniques, although some underground drift mining of placers occurred historically.

At a typical placer mine, overburden is removed to expose the pay zone. In some permafrost areas, or where other conditions require it, the pay zone is blasted to fluff-up the material and make it easier to excavate. The gold bearing gravel is then hauled by trucks to a wash plant, which consists of a combination of equipment used to size and concentrate the pay dirt. A typical wash plant consists of a grizzly where initial sizing takes place and extreme oversize material is rejected. A trammel then sizes the remainder of the plant feed. The pay dirt is then washed into a sluice or sluices, where the gold and other heavy minerals are concentrated and settle below the riffles and onto matting. The gold remains in the sluice, while the tailings and wash water flow out of the sluice and into a tailings or settling pond. The number and configuration of settling ponds varies depending on site specific conditions. The purpose of the settling ponds is to allow the solids to settle out prior to recycling the water back to the wash plant. The ponds may also serve to reduce the sediment load in any remaining water prior to discharge. Periodically, (on the order of 1 - 2 days) the wash plant is shut-down and the gold is removed. The concentrate may then be subjected to further, more refined concentration, with gravity separation techniques such as jigs, shaking tables and pinched sluices, and possibly magnetic separation if magnetite is present, to produce a high grade concentrate suitable for processing.

Mercury amalgamation was used to collect fine gold in the lowest (final) portion of a sluice. Regulations and environmental concerns have all but eliminated this procedure, except for the recent mention of a few very specialized operations, which employ mercury amalgamation. These operations function such that mercury is not allowed to escape into the environment (Thompson 1992). Otherwise, more efficient operations utilizing gravity separation have generally replaced mercury amalgamation.

#### **1.4.2 Extraction Methods**

Extraction methods employed at gold placer operations differ substantially from hard rock extraction methods. Although many placer gold operations are fairly small, relatively large amounts of overburden, waste rock, and gold bearing gravel must be excavated and concentrated to remove the trace constituent gold. The stripping ratio, which is defined as the amount of overburden and waste rock moved relative to the amount of pay dirt mined, at gold placer mines is high. At the largest placer gold mine in North America, Cambior, Inc.'s Valdez Creek Mine near Cantwell, Alaska, approximately 34,000 cubic yards of material were extracted daily. Of this, 3,000 cubic yards pass through the wash plant when it is operating, leaving approximately 90 percent of the material moved as waste. The figures for this mine site suggest a stripping ratio that approaches 10:1 (waste:ore). Other Alaskan gold placer mines had stripping ratios of 4:1 and 3:1. In the coldest regions where gold placer mining occurs, frozen overburden (consisting of vegetation, muck,

and waste rock) and gold bearing deposits must be loosened by blasting and/or mechanical means prior to extracting the pay dirt. They may also be thawed by a system or grid of water pipes circulating over the deposit. Many gold placer operations are located in extremely cold climates and remote areas. These conditions increase the difficulty of mining and associated cost of equipment maintenance. (U.S. EPA 1988a)

Gold extraction at placer operations may be conducted using either surface or underground techniques, but surface methods are most commonly used because they generally are the least expensive (Whiteway 1990). The principal surface extraction method associated with large-scale gold placer operations is open cut mining, which is synonymous with open pit mining; for the purposes of this study, the term "open cut" will be used. Other extraction methods employed at gold placer mines include dredging, hydraulicking, and other recreational and small-scale extraction techniques, such as panning and small suction dredging. Currently, use of dredging and hydraulicking methods is limited. Underground mining methods include bore-hole and drift mining, which in the past have been employed to reach deep deposits. (Alaska Miner's Assn. 1986; Argall 1987)

An article on drift mining in the *Engineering and Mining Journal* (Argall 1987) states that the prohibitive cost of mining deep shafts and long adits has prevented a major revival of drift mining. However, in Alaska there may be a resurgence in this type of mining. A few years ago nearly 100 percent of the placer mining operations used surface mining methods. However, in Alaska the industry trend toward underground placer mining suggests that use of, and dependence on, underground placer mining techniques may increase in the future. (Alaska Miner's Assn. 1986; U.S. EPA 1988a; Argall 1987; ADEC 1992)

Historically, large-scale gold placer mining operations used hydraulic methods to excavate the pay zone. Underground drift mining methods developed in the early 1900s were also used to reach rich placer deposits located far below the surface. With the advent of mechanical methods of extracting and hauling materials, hand, hydraulic, and drift mining extraction methods were displaced by mobile earth-moving equipment that was capable of handling greater volumes of material. The increase in the volume of material mined compensated for the decline in the grade of deposits (Alaska Miner's Assn. 1986). Prior to 1930, excavation equipment at open cut gold placer mines was steam-powered, but the development of the diesel engine revolutionized the industry both in Alaska and in other placer mining states. New equipment in the mid-1930s reduced costs and increased the volume of material handled. This allowed previously uneconomical deposits to be mined. Concurrent improvements were made in gravel washing and recovery systems. Technological advancements in placer mining methods generally offered operators increased flexibility and efficiency.

The selection of mining methods that maximize gold recovery and allow the safe, efficient, and economic removal of the pay dirt is influenced by several factors. The choice of mining methods is based on the physical characteristics of the placer deposits (dip, size, shape, depth, degree of consolidation), the water supply, and, ultimately, the available funds. A gold placer mining operation will usually employ a

combination of extraction methods because of the variety of conditions that must be addressed. (Whiteway 1990; U.S. EPA 1988a; Alaska Miner's Assn. 1986)

#### 1.4.2.1 Open Cut Methods

The surface mining method most commonly used in placer mining is open cut. Modern earth-moving equipment is used to mine deposits of varying size and depth. Characteristics of the deposit such as topography and condition of the underlying bedrock are important. While open cut mining is the most common method used to extract placer gold, specifics on the frequency of use of this type of surface mining relative to other mining methods are not known. (Alaska Miner's Assn. 1986)

Open cut mining involves stripping away vegetation, soil, overburden, and waste rock to reach the ore buried below. In the placer industry, the pay zone or pay streak is the equivalent of ore and may be referred to as either pay dirt or pay gravel, depending on the nature of the deposit. The pay steak can be excavated by bulldozers, loaders, scrapers, and draglines; conveyors or trucks transport the pay dirt to a wash plant for beneficiation. Usually the excavation site is located upstream or upslope of the wash plant, and the direction of the mining activity is away from the plant. Once a cut has been mined, it is generally either backfilled with excavated overburden and waste rock or converted to a water recycle or sediment pond (see Figure 1-1). (ADEC 1987)

Bulldozers are used in every phase of open cut gold placer mining operations from initial excavation to final reclamation. Primary functions include the following: stripping overburden (typically composed of vegetation, muck, and barren gravels; pushing pay gravels to sluice boxes for beneficiation; and stacking tailings. They are typically equipped with straight blades. In addition, some are fitted with rippers to break up cemented gravels and excavate bedrock containing placer gold deposited into fractures and joints. Bulldozers are also used to construct roads, diversion ditches, and settling ponds (U.S. EPA 1988a; Cope and Rice 1992; Alaska Miner's Assn. 1986).

Second to bulldozers, front-end loaders are the next most commonly utilized piece of equipment at gold placer mines. Front-end loaders are used to excavate loose or already ripped gravel. Most front-end loaders are mounted on wheels with rubber tires, but they can also be mounted on tracks. The rubber-tired loader is faster than a track loader, but it is less efficient when digging compacted in-situ gravels. (Cope and Rice 1992)

Draglines are used to excavate both dry gravels and underwater gravels, but when employed at open cut gold placer mining operations, draglines perform the same function as bulldozers (i.e., stripping overburden, moving excavated material, stacking tailings, etc.) Draglines may be fitted with booms as long as 100 feet, which gives them a large digging radius. Although it costs less per unit to move materials using draglines, they are not as mobile as bulldozers. Draglines are fitted with buckets whose capacities range from 1/2 to 2 cubic yards. A disadvantage posed by draglines is the sparse number of experienced operators. It is not clear

from the information available whether draglines are more commonly used to extract dry gravels at placer gold surface mines or to dredge underwater gravels. (Cope and Rice 1992; U.S. EPA 1988a)

#### 1.4.2.2 Other Methods

##### Dredging

Although dredges are used in both surface mining and underwater mining of placer deposits, they are generally associated with the mining and beneficiation of metal-bearing minerals (values) below water level. Dredges are limited by the availability of a saturated placer gold deposit or the existence of a water table near the surface to create the appropriate excavating environment (i.e., a pond). Some dredges, however, operate in the water while anchored on land. Four commonly used dredging systems include bucketline (also referred to as bucket-ladder), backhoe, dragline, and suction dredging. Dredges are designed to execute multiple functions. For example, many floating dredges are equipped to perform extraction, beneficiation, processing, and waste disposal. (U.S. EPA 1988a; Alaska Miner's Assn. 1986) Hydraulic dredging systems have been used to produce sand and gravel, marine shell deposits for aggregate, and mine deposits containing diamonds, platinum and tin. Heavy mineral mining, including titanium sand dredging is also practiced to obtain ilmenite, monazite, rutile and zircon (Harty and Terlecky 1986).

Dredging systems are categorized as either hydraulic or mechanical, depending on the method of digging. Hydraulic systems include suction dredges, while mechanical systems comprise bucketline, backhoe, and dragline dredges. Some dredging systems integrate hydraulic and mechanical power for the purposes of extracting placer gold. Special circumstances might make a combination dredge (sometimes called a "combiminer") more desirable than simply a plain suction dredge. Some suction dredges are equipped with a cutter head to make excavation easier. Dredges are known to be capable of excavating to depths of 225 feet, but excavation for mineral recovery has been much less, perhaps one quarter of that depth.

##### Hydraulic Methods

In hydraulic mining, or hydraulicking, water under pressure is forced through an adjustable nozzle called a monitor or giant and directed at a bank to excavate gold placer pay streak and to transport it to the recovery unit, which is generally a sluice box. The pressurized water jet can also be used to thaw frozen muck and to break up and wash away overburden. Water pressure is supplied either by a pump or by gravity. The operator controls the vertical and horizontal movements of the monitor (giant, or water cannon), as well as the water pressure and the volume of the flow by remote control (U.S. EPA 1988a).

One advantage of hydraulicking is the ability to move large volumes of material at a low cost. The amount of water required to accomplish this movement and the resultant tailings, however, present a serious obstacle to the widespread use of this water-dependent extraction technique. Originally employed in geographic areas rich with water bodies, hydraulicking tapered off as mechanized earth-moving extraction equipment gained favor and as restrictions were placed on the availability and pollution of water. Given the efficiency and

economic savings of the equipment used in open cut gold placer mining operations and concerns related to hydraulic mining's environmental impacts, it seems unlikely that hydraulic mining will be widely used in the future. (U.S. EPA 1988a)

#### Small-Scale Methods

Small-scale extraction methods include panning, and suction dredging. Small-scale extraction methods are primarily used by recreational gold placer miners working on a non-commercial scale. Small-scale methods combine extraction and beneficiation steps because the extraction phase of the placer operation is integrated with beneficiation. Essentially, shallow alluvial sediments are "sifted" using equipment that is modeled after the basic mining equipment used in some open cut and dredging operations; small-scale extraction methods employ the basic principles of gravity separation. (U.S. EPA 1988a)

Panning recovers gold concentrate. It is a low budget, labor intensive method involving fairly rudimentary gravity separation equipment. Panning is also a sampling method used by prospectors to evaluate a placer gold deposit to determine whether it can be mined profitably. Such assessment operations differ from small-scale mining operations that recover gold for an immediate return on their investment. (U.S. EPA 1988a; Alaska Miner's Assn. 1986) Small-scale gold placer miners also use a variety of other portable concentrators, including long toms, rocker boxes, and dip boxes (see Figures 1-2

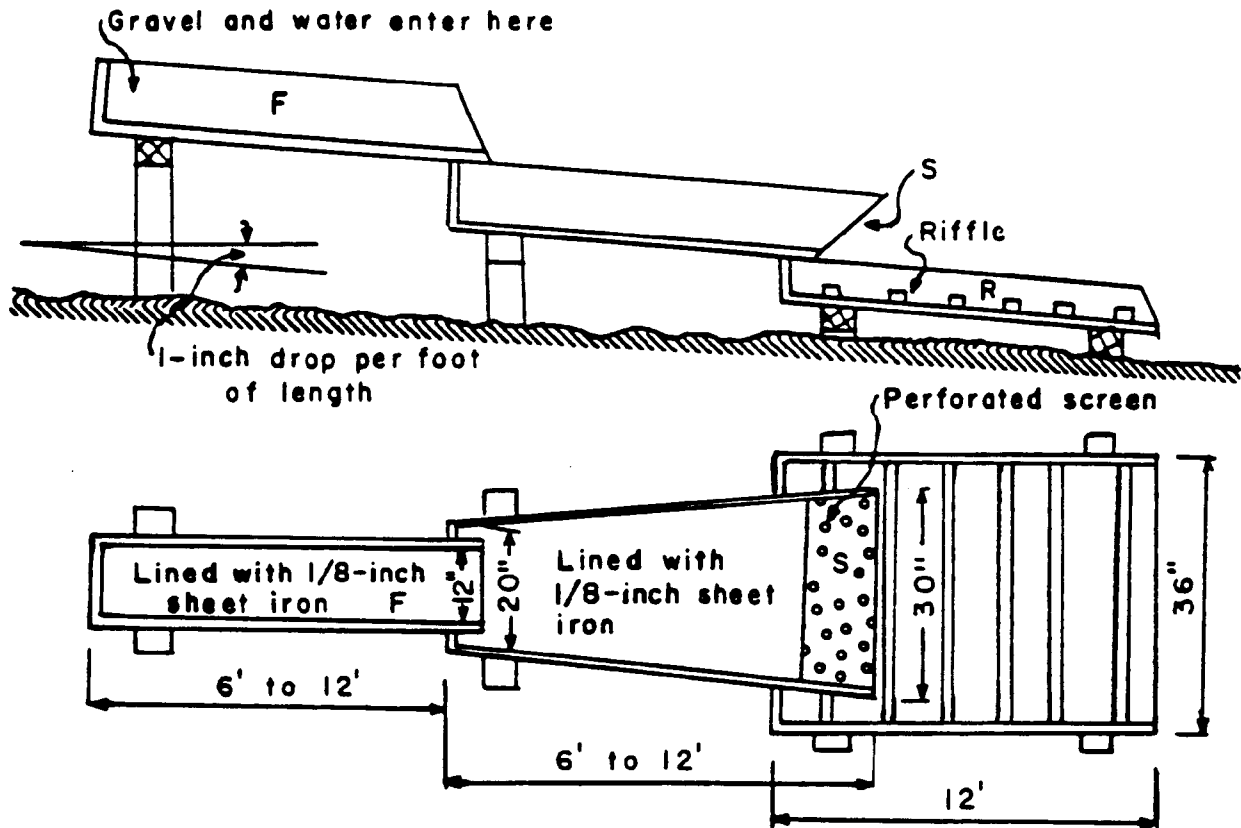

Figure 1-2. Long Tom

(Source: U.S. EPA 1988)

and 1-3). (U.S. EPA 1988a)

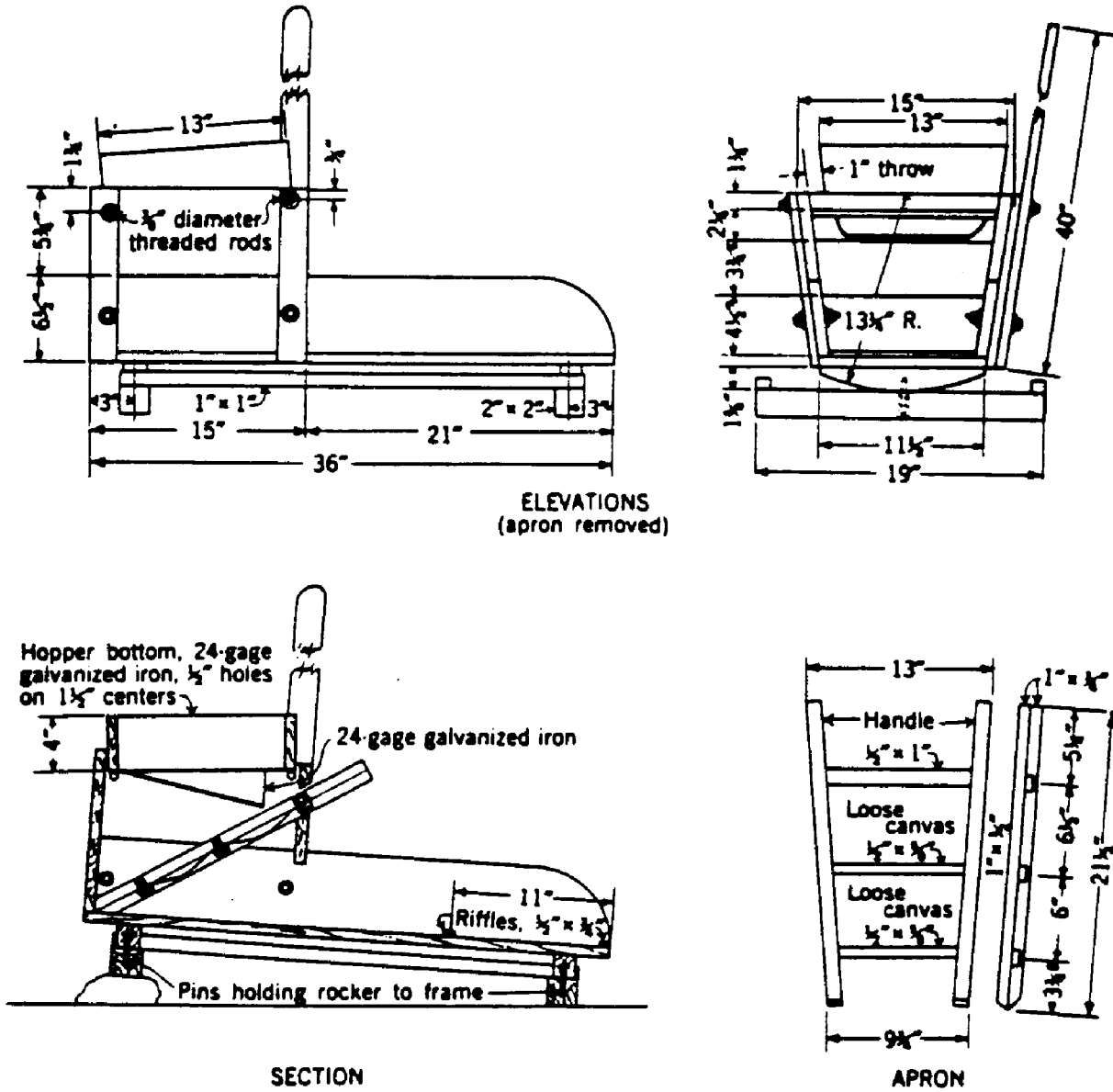

Figure 1-3. Basic Design for a Prospector's Rocker

(Source: U.S. EPA 1988)



Small suction dredges are being used successfully by recreational or small (part-time) gold placer ventures. A pump varying from one to four inches usually floats immediately above the mined area. The mechanism that recovers the gold sits in a box next to the suction pipe and is carried under water. Alternatively, the nozzle has two hoses, one that transports water to the head and the other that transports material to the surface of a beneficiation device (i.e., usually a small sluice box that deposits tails back into the stream).

#### Underground Mining Methods

Drift mining and bore-hole mining are terms applied to working alluvial placer deposits by underground methods of mining. Drift mining is more expensive than open cut sluicing and hydraulicking, so it is used only in rich ground. In drift mining, the pay streak is reached through a shaft or an adit. Pay dirt that has been separated from the gold bearing zone either by blasting or with hand tools is carried in wheelbarrows or trammed to small cars that transport the gravel to the surface for beneficiation. If a deposit is large, then regular cuts or slices are taken across the pay streak, and work is generally performed on the deposit in a retreating fashion from the inner limit of the gravel. (U.S. DOI 1968; Argall 1987)

#### **1.4.3 Beneficiation Methods**

Beneficiation of placer materials involves the separation of fine gold particles from large quantities of alluvial sediments. Gravity separation is the most commonly used beneficiation method. Magnetic separation is used in some operations to supplement the gravity separation methods. Water is used in most, if not all steps; initially, to wash gold particles from oversized material and later, to move gold concentrate through the wash plant. The wash plant refers to the collection of equipment where beneficiation is conducted. For land-based operations, the plant may be stationary but is often mounted on skids so that it can be moved along with the mining operation as it progresses. Dredge operations frequently employ floating wash plants, where the beneficiation equipment is carried within the dredge.

Beneficiation typically involves three general steps: the first is to remove grossly oversized material from the smaller fraction that contains the gold, the second to concentrate the gold, and the third to separate the fine gold from other fine, heavy minerals. The same type of equipment is often used in more than one step, for example an array of jigs may be employed to handle successively finer material (Flatt 1990).

Classification (sizing) is the initial step in the beneficiation operation when the large, oversize material (usually over 3/4 inch) is removed during beneficiation. A rough (large diameter) screen is usually used. This step may be fed by a bulldozer, front-end loader, backhoe, dragline or conveyor belt. Within the industry, this step is also referred to as roughing (U.S. EPA 1988a). Previous studies have indicated that the practice improves the efficiency of gold recovery and reduces the water consumption (Bainbridge 1979).

After the initial removal of the larger material during sizing, pay dirt is subject to a coarse concentration stage. This step, also referred to as cleaning, may employ trommels or screens. Other equipment used in the

coarse concentration stage includes sluices, jigs, shaking tables, spiral concentrators and cones. Depending on the size of the gold particles, cleaning may be the final step in beneficiation (Flatt 1990; Silva 1986).

Fine concentration is the final operation used to remove very small gold values from the concentrate generated in the previous stages. Many of the previously identified pieces of equipment can be calibrated for finer separation sensitivity. Final separation uses jigs, shaking tables, centrifugal concentrators, spiral concentrators or pinched sluices.

The following is a summary of the equipment commonly used in beneficiation. One of the key determinants in selecting equipment is the volume of material that will pass through each step within a given time period. Rates for material handling for the equipment discussed below are included where the information was available.

#### 1.4.3.1 Sizing

Sizing is a physical separation of material based strictly on size. The sizing step removes large rocks prior to additional beneficiation. The waste generated is usually solid and is much lower in volume compared to the pay dirt that passes through. Discharge material may be used for other applications including road aggregates. This step typically involves the pay dirt being loaded into a grizzly, trammel or screen or a combination thereof.

A typical grizzly consists of a large screen or row of bars or rails set at a specific distance apart (2 to 6 inches) such that undersized (gold-bearing) material can readily pass through while oversize material is rejected. Typically, the grizzly would be inclined to ease the removal of the rejected material. Water is usually used to move material through the grizzly and wash off any fines that may be attached to larger fragments before they are discarded. The undersized material drops onto a trammel, screen, or sluice depending on the operation. Grizzlies may be stationary or vibrating (U.S. EPA 1988a).

Trommels are wet-washed, inclined, revolving screens (Figure 1-4). They usually consist of three chambers, the first uses a tumbling action and water to break up aggregated material. Successive chambers are formed of screens or punched metal plates (smaller holes first) that allow the selected sized material to pass through. The screens are typically 3/8 inch in the second chamber and 3/4 inch in the final chamber. Material passing through the screens is directed for further concentration. Material passing through the trammel may be returned for a second pass or discarded (Cope and Rice 1992; U.S. EPA 1988a).

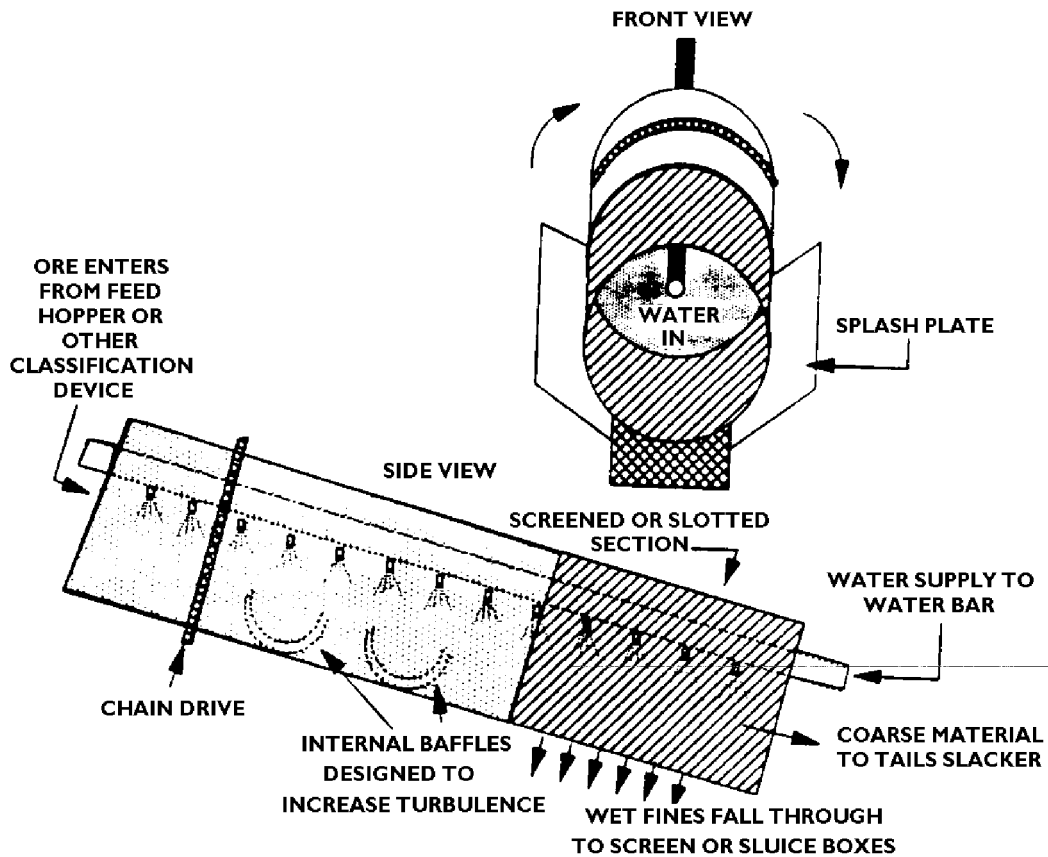

Figure 1-4. Diagram of a Trommel

(Source: EPA 1988a)

A fixed punchplate screen (also called a Ross Box) consists of an inclined plate with holes ranging from 1/2 to 3/4 inches. Pay dirt is placed onto the plate where nozzles wash the material with a high-pressure water stream. The undersized (desirable) material is washed to the outside of the plate where it is fed into a sluice designed to handle 3/4 inch material. The oversize is directed down the plate which typically has riffles to collect coarser gold. Oversized material passing off the plate is discarded.

Screens function to separate oversized, undesirable material from the gold concentrate. Screen size (usually 1/2 to 3/4 inch) is selected based on pay dirt characteristics. Screens may be fixed or vibrating. The action of both is similar although vibrating screens speed the rate of particle separation. The concentrate continues for further concentration while the oversize is removed via a chute or stacker conveyor belt. Different sized screens may be used to sort material into different sizes for use as road construction aggregate or other purposes.

## 1.4.3.2 Coarse Concentration

Separation in the coarse concentration step involves particle density rather than size. Sluices are the pieces of equipment most commonly used in the coarse concentration step although jigs and screens may also be employed. The wastes are discharged to a tailings pond also called a recycle pond or settling pond. Most of the material that enters the sluice exits as waste. The gold and other heavy minerals settle within the lining material while the lighter material is washed through. Coarse concentration generates the largest volume of waste during beneficiation.

A sluice consists of a long, narrow, inclined trough lined with riffles, perforated screens, astroturf, corduroy, burlap or a combination thereof (Figure 1-5). The sluice mimics the conditions that caused the formation of the placer deposit initially. Pay dirt is placed at the high end of the trough and washed with a stream of water. Gold and other dense minerals settle between the riffles or in the lining while the lighter material is carried through the sluice. Longer sluices are used for preliminary concentration. Shorter, wider sluices are used

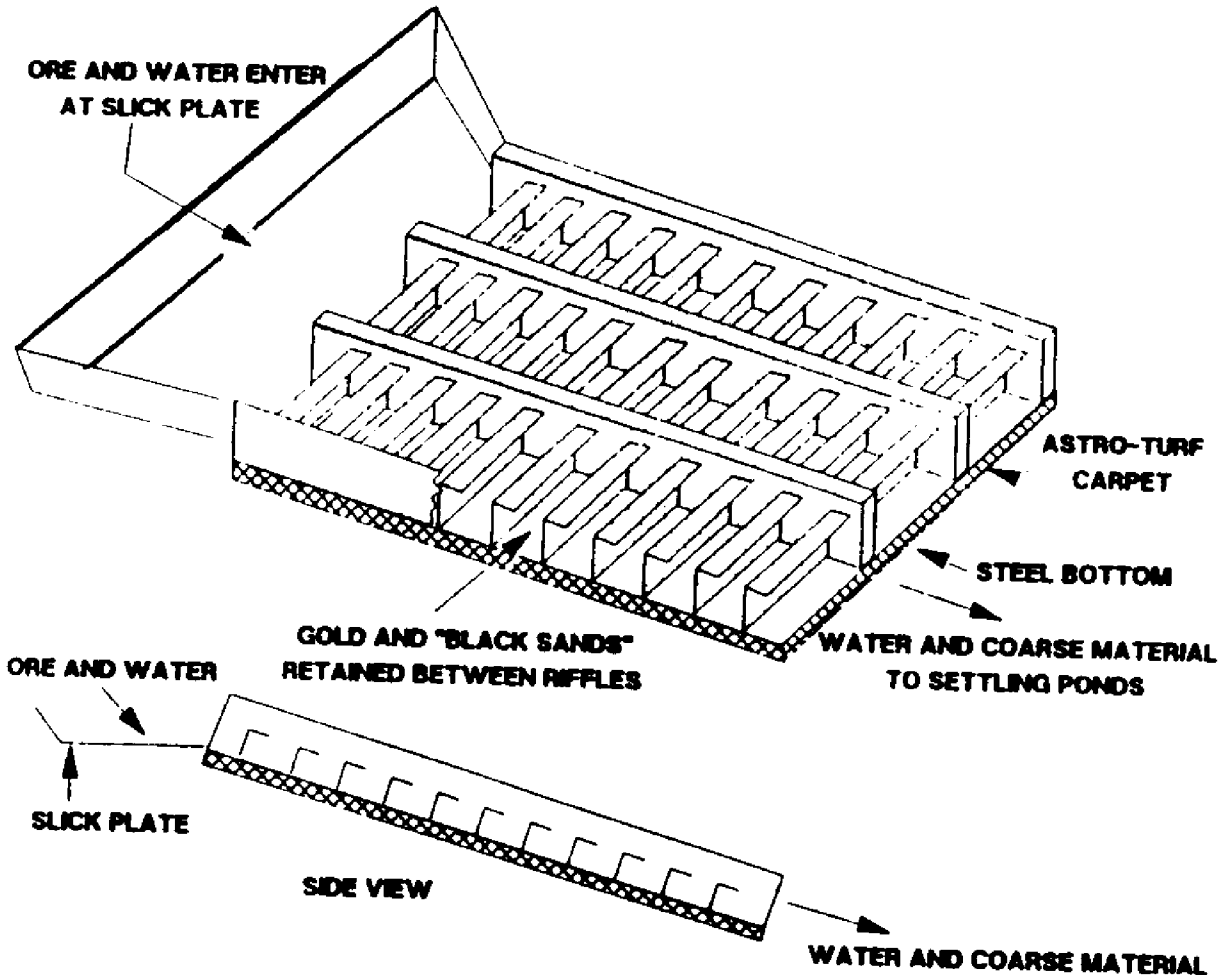

Figure 1-5. Diagram of a Sluice Box Including Hungarian Riffles

(Source: EPA 1988a)

following preliminary separation to separate fine gold from black sands. The length, grade, riffles and lining are adjusted to suit the nature of the pay dirt. However, slopes of one to two inches per foot are typical.

Riffles are bars, slats, screens or material that act to create turbulence and variation of water flow within the sluice. This action increases the efficiency of gravity separation. Riffles have ranged in size from 12 inches wide, 12 inches high and 12 inches apart to 1 inch high, 1 inch wide and 2 inches apart.

Hungarian riffles are angle irons mounted perpendicular to the sluice box. The vertical angle of the angle irons may be adjusted to affect the degree of turbulence generated and maximize gold deposition. Astroturf, carpet or coconut husks are sometimes placed between and under the riffles to maximize their efficiency. The units are usually constructed so that sections of the riffles may be removed so the gold can be recovered from the turf. As mentioned above, the height, spacing and construction of the riffles may be adjusted to maximize efficiency of gold separation depending on the character of the pay dirt.

Other material has also been tested and/or used as riffles and liners. Expanded metal riffles are employed at some operations. Like the hungarian riffles, the height, size and spacing is determined by the pay dirt and, sections are removable for cleaning. Miscellaneous materials including longitudinal or horizontal wooden poles, blocks, rocks, railroad ties, cocoa mats, rubber and plastic strips have also been documented as being used as riffles by different placer operations (U.S. EPA 1988a).

#### 1.4.3.3 Fine Concentration

After the pay dirt is concentrated, typically through a trommel and sluice, most waste material has been removed leaving a fine concentrate (the percentage of gold within the concentrate is not discussed in the references and is highly variable). The concentrate may then be subjected to fine concentration methods including jigs, shaking tables and pinched sluices. Depending on the nature of the concentrate and the equipment, 80 to 95 percent of the gold can be recovered from the concentrate at this stage. The waste at this stage is a slurry (often called slimes), and is low in volume compared to that generated in the other stages.

Jigs are settling devices that consist of a screen through which water is pulsed up and down via a diaphragm or plunger numerous times per second (Figure 1-6). A layer of rock or steel shot referred to as ragging may be placed on the screen to accentuate the up and down motion. Slurry is fed above the screen. The agitation keeps the lighter material in suspension which is then drawn off. The heavier material falls onto or through the screen and is collected as concentrate. Efficiency is increased by varying the inflow rate, pulse cycles and intensity. Jigs may handle from 7 to 25 tons per hour, and can handle particles ranging from 75 mm to 25 mm. At some operations, jigs are also employed in the cleaning stage. (Macdonald 1983; Silva 1986).

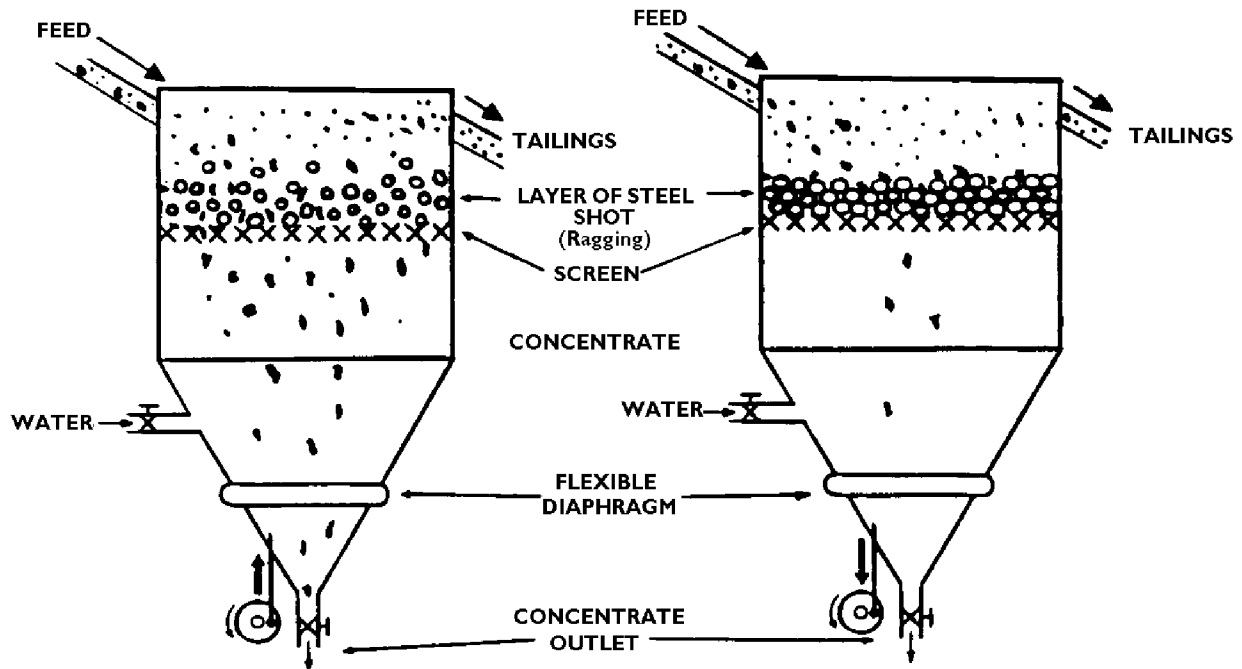

Figure 1-6. Diagram of a Jig

(Source: Cope 1992)

Shaking tables consist of small riffles over which a slurry containing fine pay dirt is passed. The gold settles into the riffles and, through a vibrating action, is directed to one side of the table where it is collected. The tails are passed across the middle of the table or remain in suspension. Middlings, material that is partially settled, may be collected. Heads and middlings are commonly reprocessed on multi-stage tables. Shaking tables can handle materials from 15  $\mu\text{m}$  to 3.0 mm (U.S. EPA 1988a; Macdonald 1983).

Spiral concentrator is a generic term referring to a method of separation rather a specific piece of equipment. Pay dirt concentrated from previous steps is fed with water, into the top of the spiral, and spins down through the spiral. The heaviest materials are concentrated toward the center of the spiral while lighter material moves to the outside. Gold particles (concentrates) are collected from the center of the spiral while the tails pass down the entire spiral. Large operations may employ multiple spiral concentrators in series to handle a wide range of sizes. Humphreys concentrators, as one example, can be used to separate particles between

100  $\mu\text{m}$  and 2 mm in diameter. These machines can handle low feed rates (1.5-2 tons per hour) and low feed density (U.S. EPA 1988a).

Centrifugal concentrators or bowls were typically used in dredges but may also be used in other operations (Figure 1-7). Slurry is fed into the top of the circular machine. Driven from the bottom, the interior portion spins on its vertical axis, driving the slurry against a series of concentric circular riffles or baffles. The lighter material (tails) is driven up the side of the bowl while the heavy material (concentrate) collects on the bottom or in the riffles (Cope and Rice 1992).

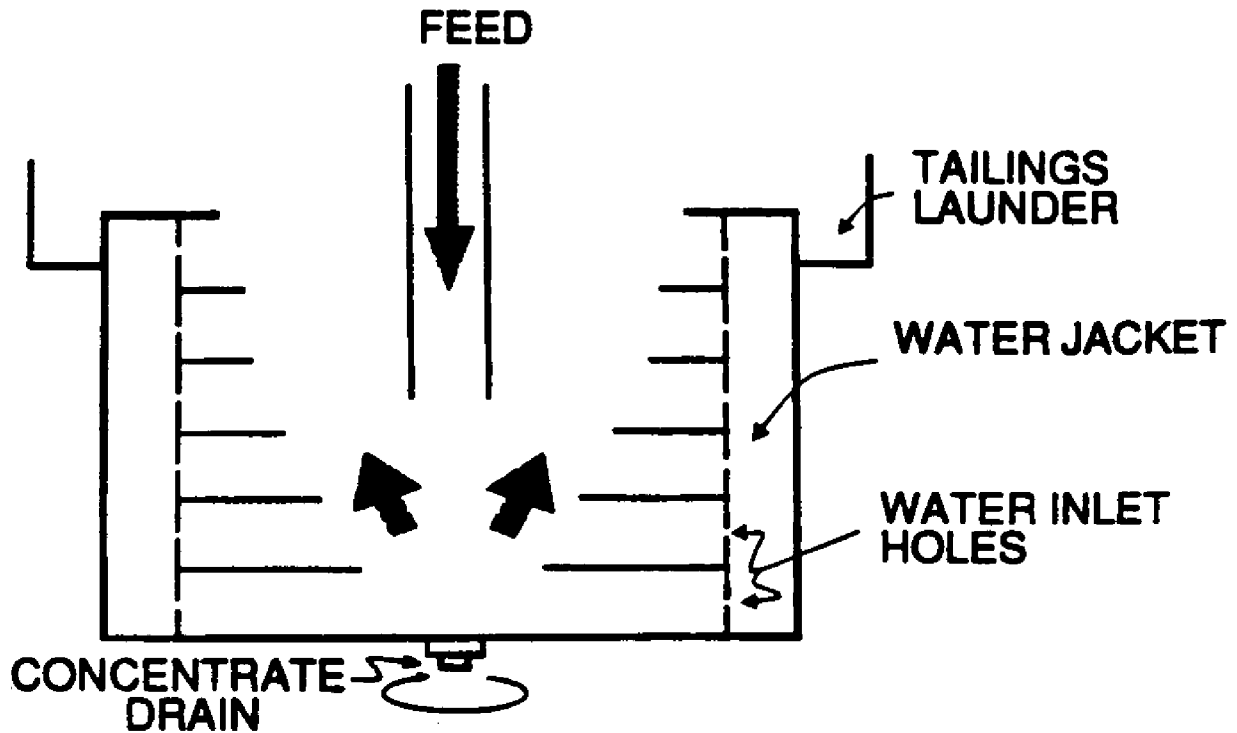
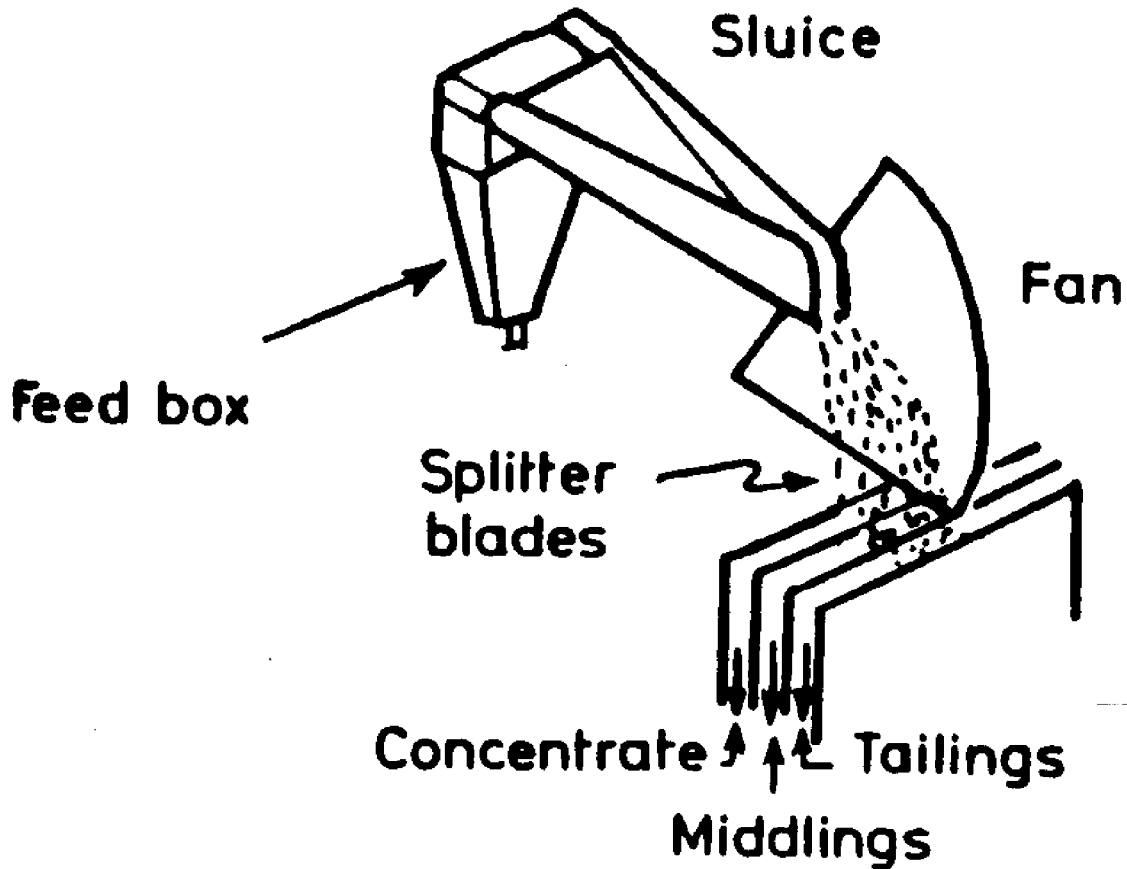

Figure 1-7. Diagram of a Centrifugal Bowl

(Source: Cope 1992)

Pinched sluices work on the concept that as a fine feed is exposed to an opening, the arc formed by the heaviest particles dropping will be much narrowed than the arc formed by the lighter materials (Figure 1-8). A divider placed perpendicular to and below the pinched outfall lets heavy materials (concentrate) collect on one side while lighter material (tails) can be collected and reprocessed separately or directed out of the operation completely. Reichert cones, which are based on the pinched sluice principle, can handle 75 tons per hour and recover particles in the minus 10 to plus 400 mesh range (45  $\mu\text{m}$  to 0.5 mm) (Gomes and Martinez 1983).



**Figure 1-8. Diagram of a Pinched Sluice**

(Source: Macdonald 1983)

Magnetic separation is not commonly used in placer mining but may be employed when magnetite is a component of the black sand. This technique is used to remove electrostatically charged tails from the neutral gold. To be effective, the method should involve multiple magnetic treatments followed by demagnetization steps so that the magnetite is removed slowly, not in a 'magnetically coagulated' form that may bind gold particles within it. Magnetic separation, when used, is one of the final steps of beneficiation. This technique is used in at least one operation in Alaska; the extent of its use in gold recovery from construction aggregates in California was not discussed (Thompson 1992).



#### 1.4.3.4 Mercury Amalgamation

Before Federal environmental regulations were promulgated in the mid-1970s, mercury amalgamation was commonly used to recover gold fines. An amalgam of mercury and gold is formed by adding mercury to the lowest portions of a sluice. There had been little or no reference to its recent use until an article in the *Engineering and Mining Journal* entitled "Byproduct Gold From Construction Aggregates" mentioned its use in recovering gold from bowl concentrates. In this case, gold concentrates were generated as a byproduct from the production of construction aggregates. The amalgam was to produce a final bullion. The mining and beneficiation operations were not described in the article. The only discussion regarding control of environmental releases simply stated that the operation was conducted away from the mining activities (Thompson 1992).

### 1.5 WASTE MANAGEMENT PRACTICES

This section describes several of the wastes and materials that are generated and/or managed at gold placer extraction and beneficiation operations and the means by which they are managed. As is noted in the previous section, a variety of wastes and other materials are generated and managed by gold placer operations.

Some, such as waste rock and tailings, are generally considered to be wastes and are managed as such, typically in on-site management units. Even these materials, however, may be used for various purposes (either on- or off-site) in lieu of disposal. Some quantities of waste rock and tailings, for example, may be used as construction or foundation materials at times during a mine's life. Many other materials that are generated and/or used at mine sites may only occasionally or periodically be managed as wastes. These include mine water removed from underground workings or open pits, which usually is recirculated for on-site use but at times can be discharged to surface waters. Some materials are not considered wastes at all until a particular time in their life cycles.

The issue of whether a particular material is a waste clearly depends on the specific circumstances surrounding its generation and management at the time. In addition, some materials that are wastes within the plain meaning of the word are not "solid wastes" as defined under RCRA and thus are not subject to regulation under RCRA. These include, for example, mine water or process wastewater that is discharged pursuant to an NPDES permit. It is emphasized that any questions as to whether a particular material is a waste at a given time should be directed to the appropriate EPA Regional office.

The first subsection below describes several of the more important wastes (as defined under RCRA or otherwise) and nonwastes alike, since either can have important implications for environmental performance of a facility. The next subsection describes the major types of waste units and mine structures that are of most environmental concern during and after the active life of an operation.

#### 1.5.1 Extraction and Beneficiation Wastes and Materials

#### 1.5.1.1 Waste Rock or Overburden

Waste rock consists of material that contains no gold and must be removed to access the pay zone. Industry usually refers to overburden and, in the case of underground mines, mine development rock as waste rock. It is generally disposed of in waste rock dumps near the point of excavation. Eventually, the stockpiled waste rock may be used to backfill the mine cut during reclamation. Because the desired material (gold) is such a small fraction of the material mined (< 0.1 oz/ton) there is a tremendous amount of waste rock generated. Surface mining operations generate more waste per unit of crude ore extracted than underground operations, although stripping ratios vary from one site to the next. For example, in 1992 at Polar Mining, Inc.'s Lower Goldstream placer operation near Fairbanks, Alaska, approximately 2,200,000 cubic yards of overburden were excavated to beneficiate 500,000 cubic yards of pay dirt. Polar Mining, therefore, has a stripping ratio that exceeds 4:1 (waste:ore). On the other hand, estimates from the 1992 Reclamation Plan and Annual Placer Mining Application of another Alaska placer mine (Alf Hopen's Little Eldorado Creek operation in the Fairbanks mining district near Cleary, Alaska) for total material mined and total material concentrated (70,000 cubic yards and 60,000 cubic yards, respectively) suggest a very low ratio of overburden to pay dirt (Polar Mining, Inc. 1991b).

Overburden removed from the mine cut is stored nearby, sometimes piled along the edge of the pit until mining ceases, at which time the waste rock is returned to the cut, or backfilled. These piles may be referred to as waste rock piles.

#### 1.5.1.2 Tailings

Material from gravity concentration operations consist of a slurry of gangue (non-gold material) and process water which passes through the concentration operation. Tailings are classified by their size into three classes: coarse or oversize tailings, intermediate tailings (middlings), and fine tailings (slimes). Of the three grades delineated, fine tailings can be further broken down into two categories. Components of the slurried tailings can be classified as settleable solids, which are made up of sand and coarse silt, or as suspended solids, composed mostly of fine silt and some clay size particles. (U.S. EPA 1988a)

Oversize tailings are separated from smaller material early during classification. Open cut operations use a grizzly to segregate larger material as the pay dirt enters the wash plant. Coarse tailings may be used in road and filtration dam construction or may be sold as aggregate. Middlings and fines generated during sluicing are usually disposed of in tailings impoundments. Ultimately, the smaller-size tailings may be covered by coarse tailings and overburden during reclamation.

Large volumes of flowing water are used to carry the pay dirt through the classification operation. The velocity of the flowing water generates a large volume of intermediate and fine tailings in the form of suspended sediment and lesser quantities of dissolved solids. Historically, the water and sediments were released to streams and created problems downstream from the mining sites. Currently, release of sediment is controlled by using impoundment structures where the water is held and the velocity is consequently reduced.

As flow is restricted sediments are deposited. Exposure of waste rock and pay dirt during extraction and beneficiation greatly increases the likelihood that soluble constituents will be dissolved. Once in solution, dissolved solids are much more likely to pass through sedimentation structures and reach surface waters.

Recycling or recirculating water at gold placer mines reduces the volume of effluent to be discharged after treatment. Water treatment is more economical when less water is flowing through the system. Production statistics from 1984 show that 21.3 percent of the Alaska gold placer mining industry achieved 90-100 percent recycle of the process wastewater (Harty and Terlecky 1984a). Operations that separate oversize tailings prior to sluicing typically use less water than mines that do not classify the excavated material (Harty and Terlecky 1984b). Where classification methods are used, approximately 1,467 gallons of water per cubic yard of pay dirt are needed, whereas at mines that do not classify material, average water usage is 2,365 gallons per cubic yard of pay dirt. (U.S. EPA 1988a; ADEC 1987)

Chemicals are not typically used during beneficiation at placer gold mines, so tailings contain the same constituents found in the extracted pay dirt. Very little use of any chemicals was found at placer sites visited by EPA in 1992. Potential natural constituents of gold placer wastes and materials include minerals that contain mercury, arsenic, bismuth, antimony and thallium as well as the minerals pyrite and pyrrhotite. These are often found in discharges from placer mines, however the Bureau of Mines states that because of the maturity of most alluvial deposits, the majority of the elemental constituents contained in these minerals are not readily soluble, especially in the conterminous forty-eight states. Some chemicals associated with gold placer mines have been identified, and these exceptions involve the addition of chemicals during beneficiation. Some California operators use magnetic separation to remove high concentrations of magnetite. At early placer mines, mercury was frequently added to sluice boxes to augment the recovery of fine gold. Mercury amalgamation produced a slurry waste composed of a mercury-tainted solution and gangue. Modern placer operations in California have recovered mercury from the sediments as a byproduct of historic amalgamation operations. The use of mercury at modern gold placer mines is considered minimal. (U.S. EPA 1991; Cope and Rice 1992)

### **1.5.2 Waste and Materials Management**

Waste and non-waste materials generated as a result of extraction and beneficiation of gold placer deposits are managed (treated, stored, or disposed) in discrete units. For the purposes of this report, these units are divided into two groups: (1) waste rock piles and (2) tailings impoundments, also referred to as settling and recycle ponds.

In general, the goal of treating or managing these materials is to separate the silt and fine-grained solids from the water, reusing the water or ensuring it meets NPDES discharge requirements prior to discharging to a stream. Most management occurs after sluicing; the stacking of overburden and waste rock in areas proximate to the mining operation, however, constitutes an interim method of managing solid extraction wastes prior to their ultimate return to the mine cut. (Alaska Miner's Assn. 1986)

There are two ways to maximize the quality of the effluent discharged from a gold placer operation. The effluent can be treated using a variety of impoundments (tailraces, pre-settling ponds, and settling/recycle ponds), filtration, and, in rare instances, flocculants. A study sponsored by the EPA in 1984 showed that polymer-aided settling removed over 96 - 99+ percent of suspended solids using cationic polymers (Harty and Terlecky 1984c). Alternatively, the mining operation can be modified to reduce water use during beneficiation, thereby reducing the volume of effluent discharged. Management methods used to achieve this reduction include classification, recycling, use of a bypass, and control of water gain (i.e., surface and subsurface seepage). (Alaska Miner's Assn. 1986)

#### 1.5.2.1 Tailings Impoundments/Settling Pond Systems

Tailings (oversize, intermediate, and fines) are typically managed in tailings impoundments or used for construction. The method of managing tailings is largely determined by the water content of the tailings. Tailings impoundments associated with gold placer mines are generally unlined containment areas for wet tailings in the form of slurries.

At most gold placer operations, the disposal of tailings requires a permanent site with adequate capacity for the life of the mine. The size of tailings impoundments varies between operations; that is, if the impoundment is going to function effectively, the dimensions and characteristics are tailored to meet the specifications for a particular operation.

The removal of sediment from water is the goal of effluent treatment. A properly designed settling pond can remove 99 percent of the settleable solids (SS) from the effluent. There are numerous factors that influence how efficiently a settling pond removes sediment from effluent, including the following:

- Surface area of the pond
- Flow rate through the pond
- Settling characteristics of the sediment
- Short circuiting
- Entrance and exit effects
- Wind and rain turbulence.

To promote settling, the surface area of the pond should be as large as possible. The flow rate through the pond can be minimized by means of a bypass that diverts excess water around the operation. Settling ponds are designed to meet the needs of a specific placer mining operation. Short circuiting occurs when the slurry in the pond flows directly from the inlet to the outlet without using the available settling area. Berms or baffles can be constructed in the pond to eliminate short circuiting, or the inlet and outlet structures can be positioned far apart from each other. Entrance and exit effects occur when the velocity of the incoming effluent creates a turbulent plume in the pond. If the slope of the tailrace is decreased or if a berm is situated at the entrance perpendicular to the flow, entrance effects can be eliminated. (ADEC 1987; Alaska Miner's Assn. 1986)

### Tailraces and Pre-Settling Ponds

The tailrace is the open channel that carries the effluent from the beneficiation plant to the settling pond. A pre-settling pond is an area of the tailrace that has been widened and deepened two to three feet to form a small pond in which heavy sediment settles and is temporarily stored. Pre-settling ponds are smaller than settling ponds, and they are less expensive to build. Pre-settling ponds require regular cleaning to remain effective, but the frequency of cleaning depends on pond size. To prevent bulldozers and other heavy equipment from getting stuck during cleaning, the pre-settling pond should be located on flat, competent bedrock, with a gentle slope on one side of the pond. When the beneficiation plant shuts down between shifts effluent in the pre-settling pond drains off completely, allowing for easy cleaning. A small berm of course tailings placed at the downstream end of the tailrace slows the flow velocity during plant operation, thereby maximizing sediment removal, while still allowing for the complete drainage of the pre-settling pond after the shift. (Alaska Miner's Assn. 1986; ADEC 1987)

Tailraces and pre-settling ponds are characteristic of open cut surface mining operations. Even at open cut mines, however, there are variations of the typical tailrace and pre-settling pond. Two pre-settling ponds are sometimes used simultaneously and in series to provide extra storage in case the first pond fills prematurely or in the event that a scheduled cleaning is missed. Alternatively, two parallel pre-settling ponds might be used at alternating times (see Figure 1-9). (Alaska Miner's Assn. 1986; ADEC 1987)

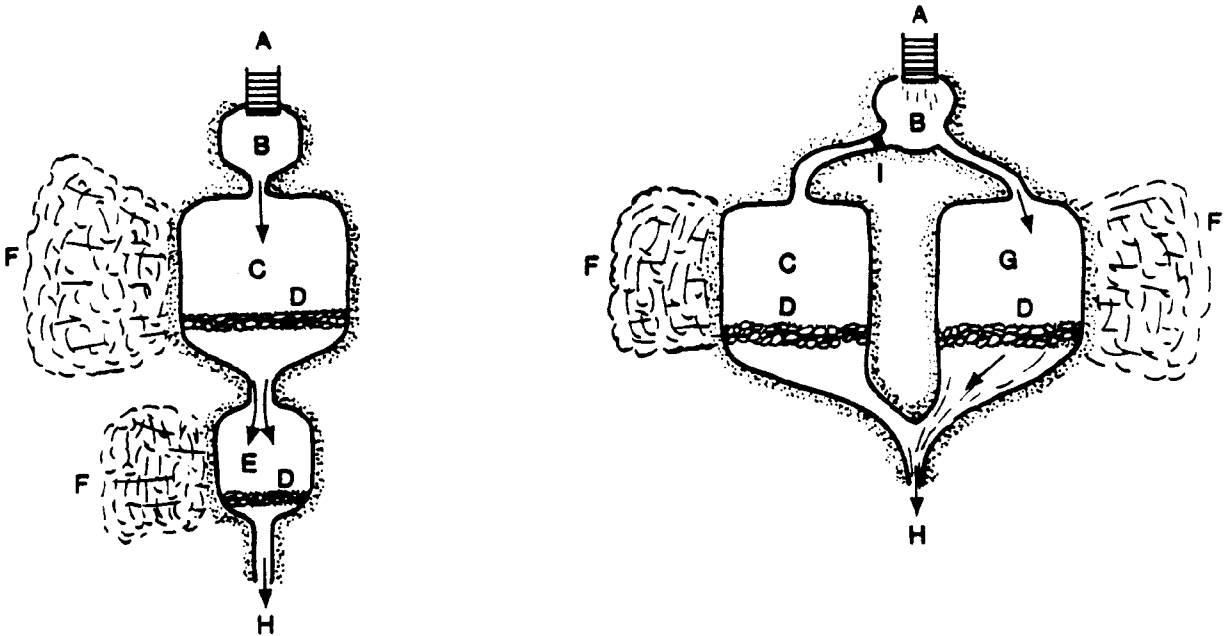
**Key**

- A Sluice box (or other primary gold recovery system).
- B Tailings sump.
- C Pre-settling pond (2 to 3 feet deep with 1 ft<sup>2</sup> surface area per gpm water flow through the pond).
- D Narrow, shallow berm of coarse tailings.
- E Second pre-settling pond (when two ponds are used in series).
- F Disposal area (for sediment removed from pre-settling ponds).
- G Alternate pre-settling ponds (when two ponds are used in parallel--sized at 1 ft<sup>2</sup>/gpm water flow).
- H To meandering tailrace.
- I Berm (to divert water into one pre-settling pond or the other).

**Notes**

- 1 Pre-settling ponds should be located in areas of competent bedrock or firm ground to prevent equipment from getting stuck during cleaning.
- 2 Pre-settling ponds, and tailraces where possible, should be bounded by at least one gentle slope so sediment can be removed by dozer, loader, backhoe, or dragline.
- 3 When located near flattened tailings pile, sediment from the pre-settling ponds can be placed on top of the tailings piles as the ponds are cleaned, thereby minimizing handling and rehabilitation costs.
- 4 Pre-settling ponds should be built so that water will drain when processing stops. The optimum time for sediment removal is after several hours of draining, commonly at the start of the next shift.
- 5 When two pre-settling ponds are used in parallel, only one should be used at a time while the other drains and is cleaned. Flow can be controlled by small berms appropriately placed in the tailings sump.

Figure 1-9. Pre-Settling Ponds

(Source: ADEC 1987)

## Filtration

Filtration of sediments can occur at two stages during management. Prior to reaching the settling pond, the tailings slurry is routed through coarse tailings, which enhance the percolation rates. Tailings filters are constructed at sites that use fixed or mobile wash plants; the latter have coarse tailings stackers that deposit the tailings in the mine cut downstream from the direction of mining (see Figure 1-10

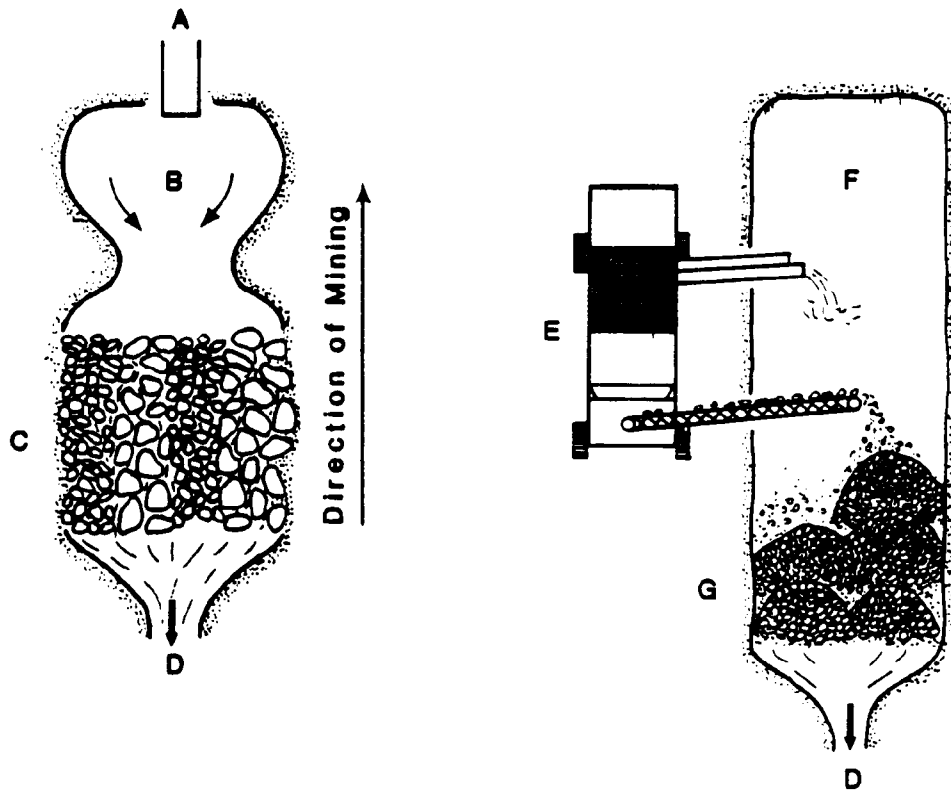

**Key**

- A Sluice box (or other primary gold recovery device).
- B Tailings sump.
- C Alternating rows of coarse and fine tailings (placed parallel to flow path).
- D Tailrace (to settling ponds).
- E Mobile washing plant (with coarse tailings stacker).
- F Settling pond.
- G Piles of coarse tailings (from stacker).

**Note**

The tailings filter for a fixed plant is ideally constructed entirely of coarse tailings to enhance the percolation rate. Fine tailings are used only when insufficient coarse tailings are available.

Figure 1-10. Sediment Removal Before Ponds by Filtration

(Source: ADEC 1987)



(ADEC 1987)

Filtration also occurs just prior to discharge of the effluent into a receiving stream. Settling ponds in series may have porous dikes or dams constructed of middlings or coarse tailings (see Figure 1-11

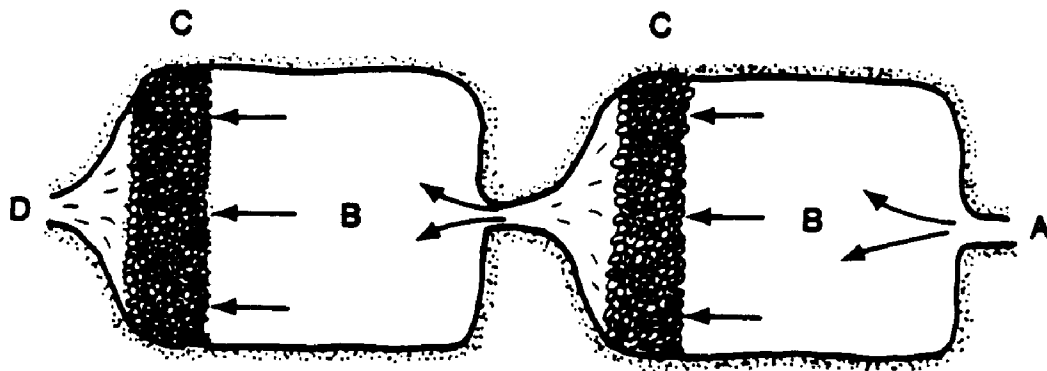

Key

- A Incoming flow (from upstream settling or recycle ponds).
- B Settling or polishing ponds.
- C Porous dikes (made of medium to coarse tailings).
- D Effluent (to further treatment or discharge).

Figure 1-11. Settling Ponds with Tailings Filters

(Source: ADEC 1987)

The more coarse the tailings, the higher the percolation rates will be. Water levels in ponds fluctuate, rising when the wash plant is actively beneficiating and falling when the plant is shut down. Tailings filters dampen flow surges through the pond, filter out solids, and mix effluent with ground water, which decreases the concentration of solids and turbidity. Finally, vegetative filtration can "polish" the effluent after other treatment methods have removed all settleable solids. (ADEC 1987)

### Settling Ponds

Settling ponds are containment areas designed to remove solids from effluent through simple settling (ADEC 1987). These structures are similar in form and function to tailings impoundments and are used primarily by large-scale placer operations. Settling ponds are usually created by constructing a dam composed of tailings across the downstream end of the mined cut. When the next cut is mined, most of the extracted sediment is captured in this new pond. Thus, as mining progresses, a series of ponds emerge. Often the main recycle pond remains intact. Settling ponds should be accurately sized and should provide for the sum of the following:

- Sediment storage volume
- Retention time volume
- Storm surge volume. (ADEC 1987)

According to the Alaska Department of Environmental Conservation, settling ponds have a length to width ratio of 2:1. Narrow ponds are less effective at removing sediment because water flows more rapidly through the pond, scouring and resuspending the sediment. Ponds should be distant from the bypass and should have adequate emergency spillways to minimize potential damage from floods. Multiple ponds (i.e., ponds in series) generally provide better treatment than one large pond.

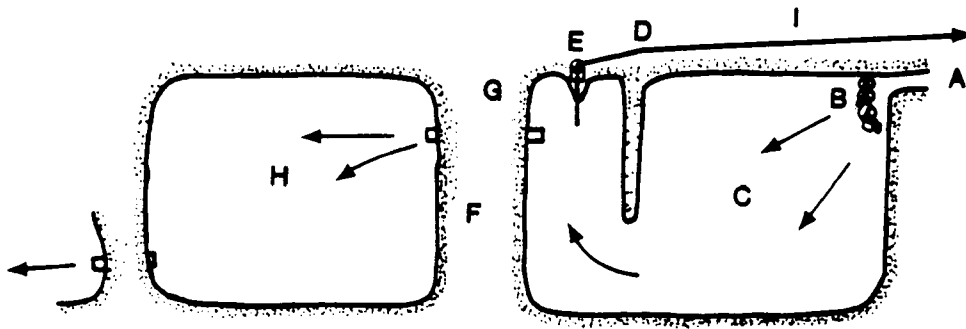
**Key**

- A Flow from upstream pre-settling or settling ponds where as much sediment as possible has been removed.
- B Coarse tailings berm to dissipate energy of incoming water.
- C Main recycle pond.
- D Dike (to prevent short circuiting through pond).
- E Peninsula on which recycle pump is located (so floating debris will not accumulate at pump).
- F Impermeable (as much as possible) dike.
- G Outlet structure (see Figures 10A and 10B for details).
- H Polishing pond.
- I Recycle pipeline (to washing plant).

**Notes**

- 1 Short-circuiting across a pond can be avoided by placing outlets across from inlets and/or by using berms or baffles to control flow paths.
- 2 The water velocity entering the pond can be decreased by reducing the slope of the tailrace as it enters the pond or by placing some boulders or large rocks where water enters the pond as shown above.
- 3 Spillways should be located away from recycle pump(s) to lessen the threat of damage from high water;
- 4 The pump should be set on the end of a small (10-foot) peninsula jutting out into the pond. This will allow the wind to blow floating sticks and debris back and forth in the pond without causing them to accumulate around the pump intake;
- 5 A floating boom or net can also be used to prevent floating debris from accumulating near the pump suction;
- 6 In a multiple pond system, a berm of very coarse tailings can often be used to filter out much of the floating debris;
- 7 In a single pond system, sediment removal from the tailrace and pre-settling ponds is more crucial to successful, long-term operation.
- 8 Discharge from properly functioning settling ponds should not be routed through old, filled ponds where it might pick up solids.

Figure 1-12. Settling/Recycle Pond

(Source: ADEC 1987)

Settling/recycle ponds in combination remove sediment from process water before it is returned to the wash plant for reuse (Figure 1-12).

Recreational and small-scale gold placer miners do not usually use settling ponds. Applying this management technology to small operations results in disproportionately large in-stream or riparian area disturbances. The use of settling ponds by small-scale gold placer miners also presents the risk of increased erosion at the site. In sum, the reduction in sediment discharge must justify the additional sediment likely to be produced by pond construction and stream diversion.

#### Flocculants

Flocculants could potentially be used as a final polishing step to reduce turbidity in a small volume of effluent from a recycle system (ADEC 1987). Chemically assisted settling may involve the addition of polymers to aid in the removal of suspended solids. For small gold placer mining operations, the addition of chemicals to the settling pond increases beneficiation costs. The danger of chemical spills and the potential for improper use of chemicals by recreational miners probably outweighs potential improvements in settling.

### **1.6 ENVIRONMENTAL EFFECTS**

Most environmental effects associated with placer mining activities concern water quality. Historically, the most severe impacts have been physical disturbances to stream channels and the addition of large quantities of sediment downstream. As regulations governing placer mining evolved to address these problems, environmental impacts became less severe, although, through the mid-1980s, water quality impacts from placer mining continued to be documented. In 1988, effluent limitations were placed on placer mines through the NPDES program (40 CFR 440 Subpart M).

Available data on environmental impacts of placers is often dated with the majority of information collected prior to 1988. Annual reports from the ADEC, and one study conducted since the effluent limitations were enacted, are discussed to provide a limited evaluation of the current status of environmental impacts.

Prior to the initiation of any regulatory controls, placer mining operations, as previously mentioned, created significant disturbances within stream channels. Little or no effort was made to recontour waste rock piles to resemble the premining topography. Natural revegetation of mined areas from Alaska to California ranges from none to complete. Depending on the remaining substrate, natural stream patterns in some areas may take a century to return. These operations were also responsible for generating large quantities of sediment and increasing concentrations of heavy metals, including arsenic, copper, lead and mercury, downstream from mining activities (ADEC 1986; Clark 1970; Holmes 1981).

This section does not purport to be a comprehensive examination of environmental effects that can occur or that actually occur at mining operations. Rather, it is a brief overview of some of the potential problems that

can occur under certain conditions. The extent and magnitude of contamination depend on highly variable site-specific factors that require a flexible approach to mitigation. EPA is aware that many of the potential problems can be, and generally are, substantially mitigated or avoided by proper engineering practices, environmental controls, and regulatory requirements.

### **1.6.1 Surface Water**

Surface water quality impacts are typically due to the addition or disturbance of sediments during mining. Increases in turbidity levels, total suspended solids (TSS), some dissolved solids (primarily heavy metals), and settleable solids (SS) are all concerns. Physical disturbances of stream channels also effect wetlands and wildlife.

A study of mined and unmined streams conducted in Alaska during the 1985 field season showed that total suspended solids were elevated in a number of actively mined streams. During this time period, sediment ponds were employed at some operations and provided a wide range of effectiveness. Downstream uses; water supply, aquatic life, and recreation were precluded as a result of the increased sediment loads in two of the three streams studied. Fine sediments were readily carried downstream in response to increased stream flows (spring runoff); therefore the severity of localized impacts could change with time as sediments were picked up and redeposited in different locations downstream (ADEC 1986).

The same study found that total dissolved solids were not categorically increased as a result of mining activities, although levels of iron, manganese, cadmium, mercury, copper and arsenic were elevated below mining operations in some streams. (It is not clear from the study whether these concentrations are expressed as total or dissolved). A study of water quality within the Circle District, Alaska, conducted in 1983, showed elevated levels of total arsenic, copper, lead, and zinc, and elevated levels of dissolved arsenic and zinc downstream from placer mining activity. Mercury and cadmium levels were not elevated downstream from mining. Concentrations of dissolved constituents are typically of more concern in terms of water quality as the dissolved fraction is available for uptake by living organisms (ADEC 1986; LaPierriere et al. 1985).

The presence of metals in mined streams is dependant on the constituents of the pay streak and the pH of the water. Arsenic behaves somewhat differently than other metals and, in actively mined streams, is associated with settleable solids, those particles smaller than 75 microns (silt and clay). Studies indicate that 84 to 88 percent of the arsenic attached to the suspended solids can be removed in settling ponds given sufficient retention time. Dissolved forms and those attached to particles smaller than 25 microns will not settle out and will be carried downstream in the mining effluent. There were no discussions that presented possible controls for other heavy metals (ADEC 1986).

Turbidity is a measure of light transmission, measured in nephelometric turbidity units (NTU). Data collected in 1985 showed turbidity ranging from 0.02 to 24 NTU upstream from mining activities; downstream from mining, turbidity ranged from 19 to 6,600 NTU. The effects of the increase in turbidity is addressed below as part of the discussion of wildlife impacts (ADEC 1986).

The effectiveness of the 1988 regulations in reducing the severity of environmental impacts has yet to be fully determined; however, the situation appears to be improving. The ADEC 1990 Annual Mining Report states that the percentage of miners whose sampled wastewater contained 0.2 ml/l or less of settleable solids had drastically improved from 1984 through 1990 (ADEC 1991). During 1989 and 1990 however, most mines requested modifications of their turbidity requirements. The regulatory requirement for turbidity was 5 NTU above the baseline level; modifications were granted based on the dilution factor provided by the receiving stream, and averaged 587 NTU (ADEC 1991).

The 1991 ADEC Annual Mining Report states that 99 percent of the mines that had a discharge and were sampled did not exceed the 0.2 ml/l limit. The report also states that the trend in settleable solids and turbidity data continue to improve (ADEC 1992). In 1991, a study of water quality associated with two mines in Alaska was conducted to evaluate the effect of reduced sediment discharges. The study evaluated the concentrations of five metals upstream from mining and in mining effluent at two locations in Alaska, one along the Fairbanks Creek and the other along Porcupine Creek. Table 1-2 presents a summary of the turbidity and arsenic data.

**Table 1-2. Turbidity and Arsenic Levels in Two Alaskan Creeks <sup>1</sup>**

| Location                               | Turbidity <sup>2</sup> | Total Arsenic |
|--|------------------------|---------------|
| Fairbanks Creek<br>Upstream location   | 1.7 NTU                | 30 ug/l       |
| Fairbanks Creek<br>Downstream location | 44 NTU                 | 89 ug/l       |
| Porcupine Creek<br>Upstream location   | 0.76 NTU               | 1.8 ug/l      |
| Porcupine Creek<br>Downstream location | 51 NTU                 | 9.1 ug/l      |

<sup>1</sup> Data are mean values for water samples collected every six hours over a four day period during the summer of 1991.

<sup>2</sup> Turbidity is measured in nephelometric turbidity units (NTUs).

As indicated by the referenced data, turbidity increased at both sampling locations downstream of mining. Neither creek exceeded the standards for cadmium, copper, lead or zinc (data not presented). Concentrations of total arsenic levels were higher downstream than upstream concentrations. The arsenic level at one mine was within the site-specific water quality limits<sup>1</sup>. The total arsenic concentration below the second mine exceeded water quality standard values (sample mean 89 ug/L, maximum 112 ug/L).

<sup>1</sup>Alaska Water Quality Standards Workbook, ADEC, 1991.

### **1.6.2 Ground Water**

The information regarding placer mining effects on ground water is sparse. One water table study conducted in Alaska found that impacts on stream hydraulics caused changes in the ground water flow regime. The study also reports that in mined stream basins, specific conductance was higher and dissolved oxygen concentrations were lower in aquifers than in the streams themselves. The differences in dissolved oxygen and conductance were not significant between aquifers and streams in unmined stream basins. The study concluded that sedimentation, as a result of mining, impacted the water quality of alluvial aquifers within mined stream basins (Bjerklie and LaPierriere 1985). Additionally, the study suggested that increased fines deposition in stream basins may reduce communication between surface water and alluvial ground water, thereby creating local zones of depression in underlying aquifers.

### **1.6.3 Soil**

By the very nature of most placer operations, soil is disturbed during mining. In many cases, topsoil is removed and set aside for future use when reclaiming a site. Redirection of stream flow and use of bulldozers and related equipment will impact soil stability and may cause greater soil erosion. Heavy equipment may denude the soil surface and cause compaction of soil, and alter soil properties such as porosity and infiltration. Loss of soil fines may decrease the water retention capacity of soils which may in turn reduce populations of microorganisms in topsoil. The degree of soil disturbance will vary from site to site and there are measures being used to minimize erosion and other impacts to soil. In Alaska, frozen ground or permafrost may suffer greater long-term damage due to the sensitivity of the environment. Specific data on soil disturbances were not available.

### **1.6.4 Wetlands**

Mining activities, particularly those mining recent alluvial deposits are likely to impact wetlands during the removal of vegetation and soils as well as the removal of the gravels that support wetland hydrology. Reclamation of the hydrologic, soil and vegetation parameters that support wetlands is currently an inexact science and the level of success in these efforts is yet to be determined on a large-scale basis.

No discussions of placer mining impacts on wetlands were located, nor has information regarding the acreage impacted by placer operations with U.S. Army Corps of Engineers Section 404 permits been obtained. However, a discussion of Section 404 dredge permits is included in the regulatory section of this report.

### **1.6.5 Wildlife**

Wildlife is impacted by placer mining through the physical disturbance of stream channels, the addition of sediments to the streams, and the presence of human activities and heavy equipment in what are typically remote areas.



Aquatic and terrestrial wildlife may be impacted by the disturbance of stream beds and adjacent alluvium by mining activities. Mining may present a physical barrier to fish migration through disruption or diversion of the active channels. Analysis of data collected during the 1985 field season found that the greater the length of disturbance within a mined stream channel, the lower the fish density upstream. The riparian areas disturbed by mining activities are typically used by birds and mammals for food, shelter and watering. Studies indicate that even on properly reclaimed areas, wildlife values are low for the first 10 to 15 years or until a relatively diverse riparian community can develop (ADEC 1986).

High sediment concentrations and turbidity adversely impact fish and aquatic invertebrates. The direct impacts from sediment on arctic grayling, the principal game fish within many Alaskan streams, include gill damage, reduced fertility, and changes in blood chemistry. Reproduction is inhibited when spawning grounds are lost to siltation and eggs are suffocated when covered by excess sediment. Additionally, fry show decreased survival rates in waters with high levels of sediment (ADEC 1986; Reynolds 1989).

Increases in turbidity levels do not cause direct effects on fish populations but can interfere with visual activities such as feeding and spawning. Additionally, a study of primary productivity (measured by dissolved oxygen and chlorophyll concentrations) showed a loss of productivity within streams impacted by mining. In the most severely impacted streams, primary productivity dropped to zero. The decreases in productivity, and the corresponding reduction in the food available at the lowest level of the food chain, were directly related to increases in turbidity (Reynolds 1989; Van Nieuwenhuysen and LaPierriere 1986).

Streams provide a general habitat for native fish populations. In addition, specialized stream habitats may be needed by certain species for spawning and rearing. Mining tends to eliminate many of the irregularities in a stream channel that provide variations in habitat such as bank and channel vegetation, shade, pools, riffles and bed texture. Some impacts from mining that might not threaten the life of individual fish may greatly affect the habitat needed by the species for successful spawning and rearing of a new generation of fry. Furthermore, mining can disrupt the food chain by adversely affecting the conditions necessary for the production of aquatic plants and invertebrates.

Although the impact to stream populations was not evaluated, Ray et al. in their 1992 study of two Alaskan creeks noted changes in water temperature, pH, dissolved oxygen, and specific conductivity. (Ray et al. 1992) Altering parameters such as these can impact aquatic ecosystems. Increases in dissolved metals in soil or water may also adversely effect wildlife.

## **1.7 MITIGATING MEASURES AND REMEDIATION**

### **1.7.1 Tailings**

The bare surfaces of tailings piles are often far above the summer water table and may have dry soils during the summer. Dry soils limit plant colonization and can cause tailings piles to stagnate in the earliest stages of plant succession. Smoothed tailings piles created by current reclamation practices are generally still too high above the summer water table for the establishment and growth of the desired plant species. Thus, the rate of plant succession is not increased by smoothing operations. Peat and topsoil respread onto tailings piles may actually retard plant succession by absorbing rainwater and keeping the underlying sediments even drier than they would be without peat. This hinders root penetration into the soil. Even grasses seeded onto reclamation areas can reduce soil moisture and inhibit or delay the establishment and growth of native plants in northern Alaska (Cooper and Beschta 1993).

One study found that for natural revegetation to be successful, the surface soil texture must contain at least 10% fine sand, silt and/or clay. Also, the soil moisture level must be between slightly dry and moist for natural revegetation to occur, in other words, the surface six inches must be moist, but not saturated during at least part or all of the growing season. Finally, colonizing type plants must be adjacent or very close on the up-wind side of the disturbed area to provide the seeds necessary for natural revegetation (Davidson 1993).

### **1.7.2 Stream Channel**

Placer mining of streams can severely alter the existing natural channel. Impacts include: removal of large, instream substrate, including boulders and woody debris; clearing of riparian vegetation from the floodplain; relocation (diversion) and straightening (reducing sinuosity and increasing gradient) of the stream channel; and isolating side channels from the main channel (Blanchet and Wenger 1993).

Scannell (1993) states that a stream system can be considered to have three conditions: what it used to be, which we may not even know; what it is now, which we can determine through sampling; and what it can become. We can often predict what it can become and what uses it can support by the type of stream channel, the flooding pattern of the stream, and even by how much money is available for reclamation. In his study, Scannell stressed that we should not equate the attainable habitat with what we perceive to be the undisturbed habitat. Instead, this study suggested that we define new habitat goals for the stream channel and work to attain them. Although it may not be practical to reclaim the hundreds of miles of disturbed stream habitat or to restore these streams to natural, or pre-mined, conditions, we can consider these streams in terms of what beneficial uses they now support and what attainable uses they might have (Scannell 1993).

Streams channels provide native species of fish with habitats necessary for migration, spawning and rearing. In addition, stream quality influences the aquatic productivity of benthic invertebrates which in turn provide food for larger fish. As a result, wildlife, and especially aquatic wildlife, can be impacted by disruptions to any of the various habitats necessary for any of the stages in the life-cycle of a species. However, in restoring

a disturbed stream channel, care must be taken not to try and force-fit a specific habitat to the existing topography of a site. Another study pointed out that stream channel gradients must be allowed to vary in relation to the topography. In the long-term, variation in channel planform, shape and gradient will provide a variety of fish habitat throughout the stream such as pools, runs, riffles, and rapids (Latoski and Chilibeck 1993).

In remediating a mined portion of stream channel, Blanchet and Wenger (1993) identified several restoration measures that can be employed to improve fish habitat such as:

- Replacing large stream substrate, including rocks and/or wood, to increase pool habitat and cover in disturbed channel reaches
- Revegetating disturbed streambanks to increase nearshore cover and wood debris supply
- Developing side channel or slough access for fish fry in disturbed areas
- Accessing adjacent abandoned settling ponds and old channels to provide additional offchannel rearing habitat.

This study went on to describe several methods for constructing instream structures to provide an increase in habitat diversity. These structures include boulders and boulder clusters keyed into the channel bottom; vortex rock weirs which are cross channel boulder structures V'ed slightly upstream and with a spacing between individual boulders; log barbs consisting of wooden logs keyed into the streambank between the high and low water levels and with the instream portion pointing upstream; root wads installed and anchored into instream pools to provide additional cover within the pool; and spruce tree revetments utilizing beetle-killed trees felled and attached along the stream bank using earth anchors to provide diverse shelter and cover for fish fry even in relatively swift water (Blanchet and Wenger 1993).

### **1.7.3 Floodplain**

Floodplains provide a means by which streams can maintain a level of equilibrium with the stream channel during times of flood. A natural floodplain provides room for a flooded stream to spread out and slow down, thereby reducing the erosive force of the water. Vegetation on the floodplain further helps to dissipate the energy of a flood-swollen stream and also helps to anchor the sediments to prevent erosion. In fact, floodplains are often the site of sediment deposition. This deposition helps to enrich the soils and make them more fertile.

Placer mining can destroy a stream's natural floodplain, replacing a broad sinuous channel and floodplain with a deep narrow channelized stream that concentrates all of its erosive power in a small area of disturbed sediments. The inevitable result is increased erosion of the stream channel and banks and increased turbidity of the down stream water.

Floodplains can be rebuilt following placer mining and stabilizing vegetation can be reestablished either through reseeding or mature plantings. Individual site conditions may dictate the means for rebuilding the floodplain. To protect against erosion, stream channels should be armored with the coarsest material available. Gravels from piles left by mining can be used to fill in settling ponds, old stream channels and other unnatural depressions. Excess gravels can be blended into the valley slope along the floodplain's margin. Depending on the geometry of the valley and stream channel, floodplains can be located on one or both sides of a stream. Typically floodplains are located on the inside of bends or meanders and along both sides in straight reaches. Double terraces can be constructed with the lower terrace designed to carry a 20 to 50 year flood, and the capacity of the upper terrace designed to carry a 100 year flood (Karle 1993).

One of the problems to be considered when rebuilding a floodplain after mining has disturbed the valley is the occurrence of a large flood before revegetation can occur. The choice between reseeding and mature plantings may be based on the probability of a damaging flood occurring before seedlings can become well enough established to withstand a flood. The probability of a flood occurring within a given period of time can be calculated using the following equation from Karle (1993). The probability **J** that a flood **P** will be equalled or exceeded in **N** years is:

$$J=1-(1-P)^N$$

For example, in an estimated five year time period for revegetation to occur, there is a 67% probability that a 5-year flood will occur or be exceeded, or a 41% probability that a 10-year flood will occur or be exceeded, and a 23% probability that a 20-year flood will occur or be exceeded (Karle 1993).

To prevent erosion of the floodplain and to encourage sediment deposition from floodwaters, brush can be planted in clumps or in linear plantings perpendicular to the stream channel. In addition, small circular ridges made by the tracks of a bulldozer driving in a pattern of tight turns can be effective in trapping precipitation runoff and small particles of sediment and airborne seeds as they tumble across the roughened surface. These small ridges have also been shown to be effective in trapping sediment when inundated by a flood (Karle 1993).

#### **1.7.4 Soils**

Soils are more than a veneer of inorganic dirt or fine-grained mineral particles over bedrock. A true soil is a combination of both mineral and organic (living and dead) material. Top soils are especially rich in organic matter. Plants require many nutrients provided by soils for proper health and growth. In some cases, revegetation after placer mining may be as simple as stabilizing the site and allowing natural revegetation to occur. In other cases, it may require replacing top soil and reseeding or replanting.

According to Helm (1993), one aspect of plant establishment is the formation of mycorrhizae on the plant roots. Mycorrhizae are symbioses between plants and fungi which are essential for growth of most plant

species under field conditions. The fungi help the plant absorb nutrients from the soil while the plant provides energy for the fungi. However, microbial communities in the rooting zone may be disrupted by natural or man-made disturbances such as glaciers, floods or placer mines.

In reestablishing vegetation on a mined site, mycorrhizal fungi propagules may enter the rooting zone of plants by natural dispersal or by their presence in topsoil or soil transfer treatments. Many placer mines are long and narrow and have a good source of propagules next to the site. Topsoil that is fresh or has not been stockpiled for too long may have viable fungi propagules present. If not, the rooting zone of seedlings or cuttings can be treated (or inoculated) with viable soil from the rooting zone of nearby plants. Different plant species can survive for varying lengths of time without mycorrhizae and studies are still underway to fully understand the requirements of mycorrhizal formation (Helm 1993).

### **1.7.5 Mined Land Remediation**

To be truly successful, remediation of a mined area needs to be undertaken with a unified ecosystem approach. Piecemeal attempts at solutions will generally not fully or successfully restore a section of placer mined stream channel. The goal of a remediation program should include the restoration of the stream channel, floodplain, and vegetation to recreate a valley bottom ecosystem similar to that occurring in undisturbed streams (but not necessarily identical to the conditions existing in a given stream prior to mining). This interaction will restore the ecological functions of these ecosystems. Goals should also be to initiate natural plant succession processes on the streambanks, floodplain and any non-floodplain portions of the mined area which will allow succession to operate at a rate similar to that on natural floodplains.

Latoski and Chilibeck (1993) state that miners must be made aware that cost effective restoration begins at the planning stage. Restoration requirements can then be integrated into the mining operation with minimal cost to the miner (e.g., stockpiling organic material and boulders, separating overburden and washed materials, etc.).

In order to implement a successful remediation project, miners should start with a clear statement of realistic goals or objectives. This should be more than just a simple recitation of the procedures to be used in restoring the stream after mining has ceased; otherwise, the restoration project may become an effort to apply a specific technique regardless of results rather than achieve a specific condition in the stream. With clear objectives identified beforehand, proper site-specific measures can be employed so that effective stream remediation is much more easily achieved.

## 1.8 CURRENT REGULATORY AND STATUTORY FRAMEWORK

Gold placer mining activities must meet the requirements of both Federal and state regulations. Environmental statutes administered by EPA or the states, such as the Clean Water Act (CWA), apply to mining sites regardless of the status of the land on which they are located. The extent to which other Federal regulations apply depends on whether a mining operation is located on federally owned land. Federal regulations exist for operations on lands managed by the U.S. Bureau of Land Management (BLM), the U.S. Forest Service (FS), the U.S. Fish and Wildlife Service (FWS), the National Park Service (NPS), and other management agencies. In addition, the U.S. Army Corps of Engineers has promulgated rules for construction and mining activities that have the potential to impact wetlands and navigable waters. Finally, operations must comply with a variety of state requirements, some of which may be more stringent than Federal requirements.

This section summarizes the existing Federal regulations that may apply to gold placer operations. It also provides an overview of the operational permitting and water quality and on quality regulations in two gold placer states, Alaska and Colorado.

### 1.8.1 Environmental Protection Agency Regulations

#### 1.8.1.1 Resource Conservation and Recovery Act

The EPA implements the Resource Conservation and Recovery Act (RCRA) to protect human health and the environment from problems associated with solid and hazardous wastes. Mining wastes are included in the Act's definition of solid waste and in 1978, when EPA proposed regulations for the Subtitle C hazardous waste program, special management standards were proposed for mining wastes. However, in 1980, RCRA was amended to include what is known as the Bevill Amendment (§3001(b)(3)(A)). The Bevill Amendment provided a conditional exclusion from RCRA Subtitle C hazardous waste requirements for wastes from the extraction, beneficiation, and processing of ores and minerals.

The exemption was conditioned upon EPA's preparation of a report to Congress on the wastes and a subsequent regulatory determination as to whether regulation under Subtitle C was warranted. EPA met its statutory obligation with regard to extraction and beneficiation wastes with the 1985 *Report to Congress: Wastes from the Extraction and Beneficiation of Metallic Ores, Phosphate Rock, Asbestos, Overburden from Uranium Mining, and Oil Shale*. In the subsequent regulatory determination (51 FR 24496; July 3, 1986), EPA indicated that extraction and beneficiation wastes (including gold mining and milling wastes) should not be regulated as hazardous but should be regulated under a Subtitle D program specific to mining waste.

EPA subsequently studied processing (i.e., smelting and refining) wastes and in 1990 submitted its *Report to Congress on Special Wastes From Mineral Processing*. This report covered 20 specific mineral processing wastes; none involved gold processing wastes. In June 1991, EPA issued a regulatory determination (56 FR

27300) stating that regulation of these 20 mineral processing wastes as hazardous wastes under RCRA Subtitle C is inappropriate or infeasible. Any mineral processing wastes not specifically included in this list of 20 wastes no longer qualifies for the exclusion (54 FR 36592).

As discussed above, wastes from the extraction and beneficiation of minerals (including gold placer operations) are generally excluded from RCRA Subtitle C requirements by the Beville Amendment and EPA's subsequent regulatory determination. EPA interprets this exclusion to encompass only those wastes uniquely associated with extraction and beneficiation activities: the exclusion does not apply to wastes that may be generated at a facility but are not uniquely related to extraction or beneficiation. For example, waste solvents that meet the listing requirements as a hazardous waste under 40 CFR Section 261.31 and are generated at an extraction or beneficiation facility by cleaning metal parts (e.g., activities not uniquely related to extraction or beneficiation) are considered listed hazardous wastes and regulated as such. These wastes must be managed as any other hazardous waste, subject to the Federal requirements in 40 CFR Parts 260 through 271 (or State requirements if the State is authorized to implement the RCRA Subtitle C program), including those for manifesting and disposal in a permitted facility.

#### 1.8.1.2 Clean Water Act

Under Section 402 of CWA (33 USC §1301, et seq.), all point source discharges to waters of the United States from industrial and municipal sources must be permitted under the National Pollutant Discharge Elimination System (NPDES). A point source is defined as any discreet conveyance, natural or manmade, which includes pipes, ditches, and channels. NPDES permits are issued by EPA or delegated states.

Under Sections 301 and 302, NPDES permittees must meet specified effluent limitations established under the CWA. Effluent limitations may be either technology-based or water-quality-based. With respect to technology-based limitations, there are separate limitations applicable to *existing sources* of discharges. They include, but are not limited to, best practicable technology (BPT) and best available technology economically achievable (BAT). Also, under the New Source Performance Standards (NSPS), new sources must use the best available demonstrated technology (BADT).

Technology-based limitations specifically applicable to the gold placer mine subcategory of the Ore Mining and Dressing Point-Source Category are codified in 40 CFR 440 Subpart M. These standards are only applicable to large placer mining operations (defined as mines which beneficiate more than 1,500 cubic yards of ore per year or dredges handling more than 50,000 cubic yard of ore per year). There are no regulations under the CWA specific to small placer mine operations.

The effluent limitation guidelines contain a storm exemption for a treatment systems designed, constructed, and maintained to contain the maximum volume of flow which would result from four hours of beneficiation plus a five-year, six-hour rainfall. Such facilities must meet best management practice (BMP) standards, as well. BMP standards require that NPDES permits include, to the greatest extent possible, provisions

addressing such things as surface water diversions, berm construction, and pollutant materials storage (U.S. EPA 1988).

In addition to such technology-based limitations, an NPDES permit may contain water-quality-based limitations. The CWA requires EPA to ensure that discharges of pollutants from a point source into waters of the United States will not interfere with the water quality. States are required to develop water quality standards to protect the designated uses of the receiving water. Where technology-based standards are inadequate to provide such water quality protection, water quality-based effluent limitations must be developed. Permit writers must determine that the technology-based standards are sufficient to ensure that such standards are being met.

Some discharges from mine sites do not meet the definition of point source discharge because they are not controlled through a discrete conveyance. These types of discharges are frequently considered nonpoint source discharges. Under Section 319 of the CWA, states are required to prepare nonpoint-source assessment reports and to develop programs to address such discharges.

Under Section 402, EPA promulgated regulations in 1990 requiring NPDES permit applications for point source storm water discharges from industrial facilities, including active and inactive/abandoned mine sites contaminated by contact with overburden, raw material, etc.. These facilities were required to submit permit applications by October 1, 1992 (U.S. EPA 1990b). Under EPA's strategy to implement permitting for industrial sources of storm water, EPA and some delegated States have issued general permits which cover mining sites. Some mining sites will be addressed with individual permits. However, these general permits do not address inactive mines on Federal lands; for these, EPA is developing a separate set of general permits.

In recent years in Alaska, the State Water Quality Standards for turbidity (normally 5 NTU above background) and total arsenic (0.05 mg/L) have been incorporated into NPDES permits. The turbidity limit may be modified depending upon the amount of dilution provided by the receiving stream. In 1989 and 1990, for example, there were 363 and 64 applications, respectively, for NPDES placer mining permits. From the 1989 applications, 338 (93%) received modified turbidity limitations allowing greater than 5 NTU; in 1990, 60 (94%) received similar modifications. (ADEC 1990.)

#### 1.8.1.3 Dredged and Fill Material

Under Section 404 of the CWA, the U.S. Army Corps of Engineers (COE) is authorized to issue permits for the discharge of dredged or fill materials, including that from gold placer mining operations, into navigable waters at specified disposal sites (Permit form 4345). Such permits may only be issued after notice and the opportunity for public hearings has been provided. A State may administer its own permit program



governing the discharge of dredged and fill materials into navigable waters by submitting to EPA a detailed description of the proposed program (and generally obtaining approval of such program) in accordance with the CWA.

Also under Section 404, EPA is authorized to prohibit the specification (i.e., use) of a defined area (or restrict the use of such an area) as a disposal site whenever EPA determines that, after notice and the opportunity for a hearing, discharge of such materials will have an unacceptable adverse effect on municipal water supplies, shellfish beds, fishery areas, wildlife, or recreational areas (in making this determination EPA must consult with the COE). The CWA requires that in specifying a particular disposal site in a 404 permit, the COE must apply guidelines developed by the EPA, in conjunction with COE. These guidelines are found at 40 CFR 230. The guidelines are intended to restore and maintain the chemical, physical, and biological integrity of waters of the United States.

Section 404 authority has been construed to extend to all waters of the United States, not just navigable waters (33 CFR 328.1). Waters of the United States have been construed to include "wetlands." Therefore, the COE issues permits for discharges to wetlands, as well as other waters of the United States. Gold mining operations (including placer operations) have a significant potential to physically restructure wetlands (U.S. EPA 1992a).

EPA and the COE use the same definition of wetlands (the U.S. Fish and Wildlife Service uses another definition). The definition is:

The term "wetlands" means those areas that are inundated or saturated by surface or ground water at a frequency and duration sufficient to support, and that under normal circumstances do support, a prevalence of vegetation typically adapted for life in saturated soil conditions. Wetlands generally include swamps, marshes, bogs, and similar areas (33 CFR 323.2(c)).

The issuance of a permit by COE may be subject to the requirements of the National Environmental Policy Act (NEPA), as such issuance is deemed a major Federal action significantly affecting the quality of the human environment (Section 511[c]).

The COE (or a State to which permit program authority has been delegated) may issue individual or general (i.e., Statewide, nationwide, regional) permits. The COE (or an authorized State) may issue a general permit, after notice and an opportunity for public hearing, for any category of activities involving discharges of dredged or fill materials where the COE (or the State) finds that the activities in such category are similar in nature and will cause only minimal adverse environmental effects when considered individually and cumulatively. General permits are widely used to speed up the Section 404 permitting-process, because they do not require detailed, case-specific review. Such permits are issued to the public at large and authorize specified activities in wetlands and other waters (U.S. EPA 1992b).

Until 1986, all discharges into waters of the United States from mining operations, including placer mining, were regulated by the COE under Section 404 as discharges of dredged materials. However, in this same year, EPA and the COE entered into an agreement (updated in 1990) which clarified the jurisdiction of the two agencies with respect to placer mining-related discharges. The agreement established that point source discharges from placer mining operations would be subject to NPDES permitting by EPA under Section 402, but that some discharges of materials incidental to such operations may still be considered dredged or fill materials, subject to Section 404 permitting by COE (U.S. EPA 1991). Such materials subject to COE permitting include material used in sediment pond construction and the filling of dredge pits. Materials from gold placer mining operations are subject to NPDES permitting as a waste discharge (U.S. EPA 1992a).

In Alaska (see following discussion of *State* permits), the State issues a Certificate of Reasonable Assurance that proposed discharges to waters in the State will be in compliance with the Alaska Water Quality Standards and the Alaska Coastal Management Plan (Department of Environmental Conservation, 1990).

Alaska recommends that if it is likely that a mining activity will affect a "wetland" (which includes all saturated soils and permafrost) a Section 404 permit application should be filed. The COE will decide whether or not the operation is likely to have an effect on a wetland. Such a decision (a "jurisdictional determination") may be based upon a field inspection of the site or on maps of Alaska (Alaska, DNR, Division of Mining, undated).

## **1.8.2 Department of the Interior**

### **1.8.2.1 Bureau of Land Management**

Gold placer operations on Federal land are subject to Bureau of Land Management (BLM) regulations. All mining claims located on lands managed by the BLM are subject to BLM regulation to prevent "unnecessary and undue degradation" of the Federal lands and resources involved. The BLM's authority to regulate mining claim operations under this "unnecessary and undue degradation" standard derives from the Federal Land Policy and Management Act of 1976 (FLPMA), the statute which sets out the BLM's general land management and planning authority. Exploration sites are subject to the less-than-5-acre exemption or must submit a plan of operation if greater than 5 acres.

BLM does not have a program geared specifically towards placer mining; placer operations are handled in the same manner as other mining operations with the same permitting, reclamation and bonding requirements. (BLM 1993a, 1993b.)

The BLM's general surface management regulations governing mining claim operations, which include gold mining operations, are found at 43 CFR Part 3809. These regulations cover general design, operating and reclamation standards, monitoring requirements, bonding requirements, environmental review requirements, and remedies for noncompliance. They establish three general use categories for mining operations, each eliciting different levels of oversight by the BLM. These categories are (1) casual use operations (i.e., those

that normally result in only negligible disturbances of Federal lands and resources and that require no prior notice to or approval from the BLM), (2) notice-level operations (i.e., those that involve disturbances of 5 acres or less for which the operator must notify the BLM prior to commencing surface disturbing activities), and (3) plan-level operations (i.e., disturbances of greater than 5 acres, and operations in some specified areas, for which the operator must obtain BLM approval of a plan of operations prior to commencing activity).

All operations, including casual use and operations under either a notice or a plan of operations, must be conducted to prevent unnecessary or undue degradation of the Federal lands. All operations must also be reclaimed and must comply with all applicable State and Federal laws, including air and water quality standards such as those established under the CAA and the CWA.

All plan-level operations, regardless of operation type (e.g., strip, open-pit, dredge, and placer) will be required to post a bond. Bond amounts are to be set at the discretion of the BLM (up to \$2,000 per acre), depending on the nature of the operation, the record of compliance, and whether it is covered by a satisfactory State bond.

Mining claims located in BLM wilderness study areas are generally subject to stricter regulation than other mining claims. The regulations covering mining in wilderness study areas are found at 43 CFR Part 3802.

The BLM has the authority to issue leases for gold on certain acquired (as opposed to public domain) lands. Although this is rarely done, such leases would be covered by the general regulations applicable to hardrock leasing found at 43 CFR Part 3500.

The National Environmental Policy Act (NEPA) of 1969 requires Federal agencies to consider the environmental impact of proposed activities. BLM uses the NEPA process to review proposed mining operations. A site may require an Environmental Assessment (EA) or an Environmental Impact Statement (EIS).

#### 1.8.2.2 National Park Service and Fish and Wildlife Service

Location of new mining claims is generally prohibited in most areas managed by the National Park Service (NPS) and the Fish and Wildlife Service (FWS). Neither the NPS nor the FWS have a specific program for gold placer operations. Regulations at 36 CFR Part 9 govern activities on land managed by the NPS under patented and unpatented mining claims in existence prior to inclusion of the land under the NPS. The NPS regulations restrict water use, limit access, and require permits and complete reclamation.

The regulations of 50 CFR Part 29 govern mining activities under mineral rights on lands managed by the FWS. The FWS regulations are fairly general and require that operations prevent, to the greatest extent possible, the damage, erosion, pollution, or contamination of the area. Leasing on FWS land is allowed only when operations are not incompatible with the aims of the refuge or other FWS center.

### **1.8.3 Department of Agriculture (Forest Service)**

Forest Service regulations are similar to BLM regulations and provide for consultation with appropriate agencies of the U.S. DOI to review technical aspects of proposed plans of operation. Unlike BLM, the Forest Service regulations do not specify acreage limitations. Although the BLM has general management authority for the mineral resources on Forest Service lands, the BLM regulations governing activities under mining claims do not apply to units of the Forest Service. Instead, surface uses associated with operations under mining claims on Forest Service lands are governed by regulations in 36 CFR Part 228, Subpart A. The general regulations apply to placer operations, however; there are no special provisions for these operations.

The Forest Service requires a notice of intent to operate; this notice is filed with the district ranger. If the district ranger determines that the operations will be likely to cause significant disturbance of surface resources, the operator must submit a proposed plan of operations. Neither a notice of intent nor a proposed plan of operation are required for the locating or marking of mining claims, mineral prospecting that will not cause significant surface disturbance, operations that do not involve mechanized equipment or the cutting of trees, or uses that will be confined to existing roads.

Like the BLM, the Forest Service may require an environmental assessment or environmental impact statement according to the National Environmental Policy Act (NEPA) program. Bonds are required to cover the cost of reclamation. Regulations specific to mining operations in Wilderness Areas are addressed in 36 CFR Part 293.

### **1.8.4 State Programs**

#### **1.8.4.1 Alaska**

Exploration, claim staking, permitting, mining, and reclamation in Alaska is regulated by several State agencies. (Federal agencies also issue permits for activities in Alaska; see above). Among the State regulatory agencies with regulatory authority applicable to gold placer mining operations are: the Department of Natural Resources' Division of Mining; the Alaska Department of Environmental Conservation; and the Alaska Department of Fish and Game. State permitting authorities are discussed below. Also included is an overview of Alaska's reclamation and bonding regulations, as they apply to gold placer mining operations.

#### **The Annual Placer Mining Application**

The Annual Placer Mining Application (APMA) form must be completed and submitted to the Division of Mining (DoM) for all mining activities except for lode or hardrock mining. The APMA form is *not* itself a permit, but rather an application which may serve as the basis for the issuance of a number of required permits in Alaska. If this form is submitted along with a \$100 application fee, the completed form is sent by DoM to numerous Alaska (and Federal) agencies, such as the Alaska Department of Fish and Game (see discussion of "Title 16 permits" below) and may, at the discretion of receiving agencies, serve as the basis for issuance of their respective permits. Federal agencies which receive copies of the APMA include the Federal

land managers (Forest Service or Bureau of Land Management) (if the site is on Federal lands) and the National Park Service (if the site is on land under its control).

The APMA saves time for miners in that they may not have to complete individual permit applications for each permit required in the State. However, the APMA will not suffice as the application for a NPDES or Section 404 permit, as specific permit application forms are required for such permits. Also, since acceptance of the form for the issuance of a particular permit (e.g., National Park Service permit) is discretionary, the particular agency receiving the permit application form may request that additional or supplemental information accompany the APMA form.

The APMA form includes a reclamation plan form and a Statewide bond pool form (see following discussion on reclamation and bonding regulations). The bonding pool was established in Alaska for operations over five acres and which are on State land and for all unreclaimed areas on Bureau of Land Management operations. The total cost to join the pool is \$150 per acre.

The application requests information concerning the intended placer mining method (e.g., suction dredge, bucket line dredge), make-up water supply, recycling/settling pond system (e.g., length and depth), overburden, access, and exploration trenching and drilling. Also, the form contains a *Coastal Zone Management (CZM) Certification Statement* (Certification Statement) that must be completed by applicant's whose proposed operation is located in the Coastal Zone. The Certification Statement is intended to satisfy the requirements of the Federal Coastal Zone Management Act, which requires, among other things, that applicants for permits to conduct activities affecting land or water use in Alaska's coastal area provide certification that the activities will comply with the standards of the Alaska Coastal Management Program (State of Alaska, Department of Natural Resources, Division of Mining 1992).

#### Title 16 Permit

This permit is issued by the Alaska Department of Fish and Game under Alaska law. Its purpose is to protect Alaska's anadromous fish, especially salmon. The mining activity must not interfere with the safety of the fish. Also, the Department's permitting authority extends to the establishment of a "fishway," which means basically that mine sites must provide adequate passage for the fish. Title 16 permits require the best management practices be applied to ensure that normal flow of creek is segregated from active mining area.

#### Dam Safety

The Alaska Department of Natural Resources, Division of Water issues permits to ensure dam safety. Plans for dam construction must be reviewed and approved by the Division prior to construction, and monitoring is conducted during construction to ensure compliance with the approved plans. The State has three categories of dams based on hazard risks: high, significant and low risk. The categories are essentially similar to that used by the Army COE. Dams that are categorized as high or significant risk require inspections at a minimum of once every three years. Low risk dams require inspections at least once every five years.

Inspections are the responsibility of the dam operator, although the State reviews and approves qualifications of the individuals or firms selected to perform the inspections. (Alaska DNR 1993.)

According to the laws and regulations of the State, a permit is required to close or abandon a dam. The applicable State statute is the Alaska Dam Safety Act (1987); Dam Safety Regulations (1989) are contained in 11.A8293 Article 3. (Alaska DNR 1993.)

#### Other State Permits

Other permits are required by the State for activities related to gold placer mine operations, but are outside the scope of this examination. One such permit concerns water access rights of miners. Generally, a permit to allow miners' access to waters for mining operations is required from the DNR's Division of Land and Water.

#### Reclamation and Bonding

Under Alaska Statute 27.19, Alaska requires reclamation plans and bonding for all material mining operations on State, Federal, municipal, and private lands, where such operations involve a mined area of five acres or more. (The APMA, discussed previously, includes forms to address these requirements). Also, BLM requires reclamation bonding of all operations on Federal lands regardless of size.

The regulations promulgated pursuant to Statute 27.19 contain reclamation performance standards which require that miners reclaim areas disturbed by mining operations so that any surface that will not have a stream flowing over it is left in stable condition. "Stable condition" is one which allows for "...the reestablishment of renewable resources on the site within a reasonable period of time by natural processes" and which can be expected to return waterborne soil erosion to pre-mining levels within one year after the reclamation is completed and can achieve revegetation.

Reclamation regulations also address bonding requirements and reclamation plan submittal and approval. At least 45 days before commencement of mining activities, a miner must submit a proposed reclamation plan to the State for approval. Within 30 days of determining that the plan is complete, the State must approve, disapprove, or conditionally approve the plan. The plan does not take effect until the miner satisfies the bonding requirements.

Plans submitted on forms other than the one provided by the State (i.e., APMA) must include information such as:

- list of all properties, mining locations, and leases on which the mining operations are to be conducted;
- a map showing the vicinity of the operation;

- general description and diagram of the operation and mined area, including acreage to be mined in each year covered by the plan;
- estimated number of yards or tons of overburden or waste and ore/materials to be mined each year; and
- a description of the reclamation measures to be taken, including a time schedule.

In addition to plan submittal (and approval), *all miners* except for exempt miners (discussed below), must comply with bonding provisions. Bonding requirements allow for any number of options to satisfy the financial assurance provisions. Some of the options include:

- participating in a statewide bonding pool (which basically allows a miner to pay into a pool each year 15% of the miner's total bond amount for the year, plus an annual fee of five percent the total bond amount [this usually results in a bonding pool deposit of \$112.50 per acre and a fee of \$37.50 per acre]);
- posting a performance bond [either a corporate surety bond or a personal bond accompanied by a letter of credit, certificate of deposit, or cash or gold deposit]; or
- posting a general performance bond assuring that reclamation standards are met and which is for no less than \$750 per acre of mined area (11 AAC 97 1992).

Operations smaller than five acres are exempt from bonding requirements, as well as the requirement to submit a reclamation plan. However, such exempt miners must file, annually, a "letter of intent" prior to commencement of mining activities. The letter must include most of the information required for non-exempt mining operation required in reclamation plans, but non-exempt miners do not have to obtain approval of the data in the letter. The data required in the letter of intent includes the following: a list of properties and mining location or leases on which operations will be conducted; a map of the general vicinity of the mining operation; and total acreage to be reclaimed in the year covered by the letter of intent.

#### 1.8.4.2 Colorado

The primary State mining law is the 1976 Colorado Mined Land Reclamation Act (MLRA) (34-32-101 et seq. C.R.S.), which succeeded the Colorado Open Land Mining Act of 1973. (ELI 1992)

Colorado has a number of placer mines, although the number in actual operation at any one time varies. Almost all of the placer mines in Colorado operate on an intermittent basis, fluctuating seasonally or with market prices. Colorado does not have specific regulations for placer mining; placer mines in the state must adhere to the same regulations as other mines. Colorado regulations are fairly generic for all mining operations; specific requirements are written into each individual permit (Colorado DNR 1993).

The Colorado Department of Natural Resources, Division of Minerals and Geology administers the MLRA, while the Mined Land Reclamation Board issues rules and regulations, reviews permits, and oversees

enforcement. Nonpoint source and ground water discharges at mining operations also are under the jurisdiction of the Division of Minerals and Geology.

Although Colorado does not have specific guidance or policy for placer operations, some of the applicable mining program elements are highlighted below.

#### Mining and Reclamation

All placer operations must have a permit if they mine and sell gold. Regular operating permits are required for mining operations affecting ten acres or more, or extracting 70,000 tons/annually (mineral and/or overburden). The State issues limited impact operation permits to facilities less than ten acres in size. A further distinction is made for those operations that are less than ten acres and are located in or adjacent to stream channels, or on certain Federal or State recreational or wilderness lands. Approximately 50 percent of the State's placer operations are less than ten acres in size. Special applications for two acre limited impact facilities are processed on an expedited basis and require financial assurance bonds of only \$1500 (ELI 1992; Colorado DNR 1993). New mines require reclamation permits under the MLRA prior to beginning operations.

A notification of temporary cessation is required if a facility will cease operations for more than 180 days. The facility must ensure that the facility is stabilized prior to cessation, and the Division of Minerals and Geology may conduct inspections to verify facility compliance with this. The Mined Land Reclamation Board typically reviews the temporary cessation notice (Colorado DNR 1993). Because most placer operations in the State are intermittent, the temporary cessation policy is particularly important to placer mining operations. A five year period is allowed for temporary cessation; after an inactive period of five years, a facility must begin reclamation. A facility may apply for a second five year period of inactivity, although the Mined Land Reclamation Board will conduct a thorough review of the facility plans prior to authorization.

All permits issued by the Mined Land Reclamation Board require financial assurances, including placer operations. The dollar amount of financial assurances varies depending on the type and extent of operation, and the estimated reclamation costs. Financial assurances are required throughout the life of the permit until reclamation has concluded. Concurrent reclamation of placer operations is encouraged by the State through bond mechanisms. Bonds are typically lower for facilities conducting concurrent reclamation. Usually a disturbed acreage limitation is listed in a facility's reclamation permit, no more than two acres can be disturbed at any one time for example, and prior to excavating a new area the old area must be reclaimed (Colorado DNR 1993).

Counties with zoning requirements may issue, through the zoning committees, a certificate of designation, which is akin to a land-use permit. The level of involvement of Counties in issuing mining permits is quite variable throughout the State. Sites on public lands may be jointly reviewed by the State and BLM or Forest Service.



## Surface Water Discharges

Water quality and releases related to mining are regulated by the Colorado Department of Health, Water Quality Control Division and the Water Quality Control Commission under the State's Water Quality Control Act. Water quality standards are set by the Division, and permits are issued for discharges to surface water through NPDES/Colorado Discharge Permit System (CDPS) permits. Colorado has a federally-approved NPDES program. The Permits and Enforcement Section, Industrial Unit, of the Water Quality Division issues CDPS permits, which are required for all active mines that have a point source discharge to surface water.

There is a CDPS general permit for placer mining. The general permit covers water used to transport alluvial material through a separator, runoff crossing the disturbed area, surface and ground water associated with placer mining activities, and other process water as determined by the Water Quality Control Division (ELI 1992). There is a CDPS general permit for Stormwater Discharges Associated with Metal Mining Operations, Permit No. COR-040000, issued September 14, 1992, and valid through September 30, 1996 (Colorado DOH 1992). Site specific dredge permits (per Section 404 of CWA) may also be required at some placer sites.

Colorado has a Passive Treatment of Mine Drainage (PTMD) program for controlling drainage that is not subject to NPDES/CDPS requirements. The PTMD program approves construction, operation, and sets standards for systems used to control mine drainage. The program covers biological, geochemical and physical drainage control or treatment measures such as cascades, settling ponds, and man-made wetlands (standard reclamation measures are not included under PTMD). (ELI 1992.)

**1.9 REFERENCES**

- Alaska Department of Environmental Conservation. 1986. *A Water Use Assessment of Selected Alaska Stream Basins Affected by Gold Placer Mining*. Prepared by Dames & Moore, Arctic Hydrologic Consultants, Stephen R. Braund and Associates, L.A. Peterson and Associates, and Hellenthal and Associates.
- Alaska Department of Environmental Conservation. 1987 (March). *Placer Mining Demonstration Grant Project Design Handbook* (prepared by L.A. Peterson & Associates, Inc.). Fairbanks, AK.
- Alaska Department of Environmental Conservation. 1988 (June 3). Placer Mine Inspection Form, with an EPA NPDES Compliance Inspection Report cover sheet dated August 2, 1988 and signed by Conrad Christianson.
- Alaska Department of Environmental Conservation. 1989 (December 19). Decision Record, with attachments.
- Alaska Department of Environmental Conservation. 1990. *1990 Annual Mining Report*. Alaska Department of Environmental Conservation, Division of Environmental Quality. Fairbanks, Alaska.
- Alaska Division of Mining. 1992 (May 6). *Alaska Division of Mining Approved Reclamation Plan*. Approved by John E. Wood.
- Alaska Department of Natural Resources. 1992a (February 21). Alaska Department of Natural Resources Case File Abstract.
- Alaska Department of Natural Resources, Division of Geological and Physical Surveys. 1992b (February). *Alaska's Mineral Industry 1991 Survey* (by T.K. Bundtzen, R.C. Swainbank, J.E. Wood, and Albert Clough). Information Circular 35. Fairbanks, AK.
- Alaska Department of Natural Resources. 1992c (April 27). Alaska Department of Natural Resources, State Wide Bond Pool Form.
- Alaska Department of Natural Resources, Division of Mining. 1992d. Annual Placer Mining Application, with attachments.
- Alaska Department of Natural Resources, Division of Water. 1993. Kyle Cherry, personal communication with Michelle Stowers, Science Applications International Corporation, Falls Church, Virginia, on June 15, 1993.
- Alaska Department of Natural Resources, Division of Mining. Undated. Letter to potential miners/prospectors on permits required for mining, reclamation, or mineral exploration in Alaska.
- Alaska Miners Association. 1986. *Placer Mining -- A Systems Approach*. Short Course, Alaska Miners Association Eleventh Annual Convention, October 29-30, 1986. Anchorage, Alaska.
- Argall, G.O., Jr. 1987 (December). "The New California Gold Rush." *Engineering & Mining Journal*: 30-37.

- Bainbridge, K.L. 1979. *Evaluation of Wastewater Treatment Practices Employed at Alaskan Gold Placer Mining Operations*, Calspan Corporation Report No. 6332-M-2.
- Bjerklie, D.M. and J.D. LaPierriere. 1985 (April). Gold-Mining Effects on Stream Hydrology and Water Quality, Circle Quadrangle, Alaska. *Water Resources Bulletin*: 235-242.
- Blanchet, D. and Wenger, M. 1993. Fisheries Habitat Restoration in Placer Mined Reaches of Resurrection Creek. *In Papers of the Second EPA Placer Mine Reclamation Workshop*. U.S. EPA publication # EPA 910-R-93-015.
- Boyle, R.W. 1979. *The Geochemistry of Gold and Its Deposits*. Canada Geological Survey Bulletin 280. Canadian Publishing Centre. Hull, Quebec, Canada. 584 pp.
- Clark, W.B. 1970. *Gold Districts of California*. California Division of Mines and Geology, Bulletin 193. San Francisco, CA.
- Code of Federal Regulations*. Section 40, Part 440, Subpart M -- Gold Placer Subcategory. 1989. Office of the Federal Register, National Archives and Records Administration. Washington, DC.
- Colorado Department of Health, Water Quality Control Division. 1992 (September). *CDPS General Permit, Stormwater Discharges Associated with Metal Mining Operations, Authorization to Discharge Under the Colorado Discharge Permit System*, Permit No. COR-040000, Issued September 14, 1992.
- Colorado Department of Natural Resources, Division of Geology and Minerals, 1993. Bill York-Fern, personal communication with Michelle Stowers, Science Application International Corporation, Falls Church, Virginia, June 9, 1993.
- Cooper, D.J. and Beschta, R.L. 1993. Restoration of a Placer Mined Valley Bottom in Interior Alaska: Birch Creek at Steese Highway Mile 99. *In Papers of the Second EPA Placer Mine Reclamation Workshop*. U.S. EPA publication # EPA 910-R-93-015.
- Cope, L.W., and Rice, L.R. (editors). 1992. *Practical Placer Mining*. Society for Mining, Metallurgy, and Exploration, Inc. Littleton, CO.
- Davidson, D.F. 1993. A Preliminary Inventory of Abandoned Mine Sites on the Chugach Nation Forest and the Present State of the Natural Vegetation. *In Papers of the Second EPA Placer Mine Reclamation Workshop*. U.S. EPA publication # EPA 910-R-93-015.
- Environmental Law Institute. 1992 (November). *State Regulation of Mining Waste: Current State of the Art*, prepared under Grant Agreement No. X-818255-01-0, funded by the U.S. Environmental Protection Agency.
- Ferguson, J.F. and Gavis, J. 1972. "A Review of the Arsenic Cycle in Natural Waters." *Water Research*: 6:1259-1274.
- Flatt, P. 1990 (March). "Fine Placer Gold Recovery Methods." *California Mining Journal*: 5-8.

- Gomes, J.M. and Martinez, G.M. 1983. Recovery of Gold and Other Heavy Minerals From Alluvial Deposits: Equipment and Practices. *In The Encyclopedia of Placer Mining* (R.A. Hatkoff, ed.) Inter Resources Publications, Lakewood, Colorado.
- Harty, D.M. and Terlecky, P.M. 1980. *Titanium Sand Dredging Wastewater Treatment Practices*, Frontier Technical Associates, Inc. Report No. 1804-1 for the U.S. Environmental Protection Agency, Effluent Guidelines Division.
- Harty, D.M. and Terlecky, P.M. 1984a (February). "Existing Wastewater Recycle Practices at Alaskan Placer Gold Mines", Frontier Technical Associates, Memorandum to B.M. Jarrett, U.S. EPA, Effluent Guidelines Division.
- Harty, D.M. and Terlecky, P.M. 1984b (February). "Water Use Rates at Alaskan Placer Gold Mines Using Classification Methods", Frontier Technical Associates, Memorandum to B.M. Jarrett, U.S. EPA, Effluent Guidelines Division.
- Harty, D.M. and Terlecky, P.M. 1984c. "Reconnaissance Sampling and Settling Column Test Results at Alaskan Placer Gold Mines", Frontier Technical Associates Report No. FTA-84-1402/1, prepared for U.S. EPA, Effluent Guidelines Division.
- Hatkoff, R.A. 1983. *The Encyclopedia of Placer Mining*. Inter Resources Ltd. Denver, CO.
- Helm, D. 1993. Reclamation, Succession, and Mycorrhizae in Alaska. *In Papers of the Second EPA Placer Mine Reclamation Workshop*. U.S. EPA publication # EPA 910-R-93-015.
- Herkenkoff, E.C. 1987 (December). Snake River Placers Host Elusive Flour Gold. *Engineering & Mining Journal*: 42-45.
- Holmes, K.W. 1981 (January). Natural Revegetation of Dredge Tailings at Fox, Alaska. *In Agroborealis*: 26-29.
- Karle, K.F. 1993. Stream and Floodplain Reclamation on Glen Creek in Denali National Park and Preserve. *In Papers of the Second EPA Placer Mine Reclamation Workshop*. U.S. EPA publication # EPA 910-R-93-015.
- LaPierriere, J.D., Wagener, S.M. and Bjerklie D.M. 1985 (April). Gold-Mining Effects on Heavy Metals in Streams, Circle Quadrangle, Alaska. *Water Resources Bulletin*: 245-252.
- Latoski, D. and Chilibeck, B. 1993. Placer Mining and Fish Habitat Restoration in the Yukon. *In Papers of the Second EPA Placer Mine Reclamation Workshop*. U.S. EPA publication # EPA 910-R-93-015.
- Lucas, J.M. 1992 (November). Personal communication between J. Lucas, U.S. Bureau of Mines, Washington, DC. and G. Weglinski, Science Applications International Corporation, Denver, Colorado.
- MacDonald, E.H. 1983. *Alluvial Mining, the Geology, Technology and Economics of Placers*. Chapman and Hall. New York, NY. 508 pp.
- Memorandum. 1988 (August 9). From Paul Bateman to Pete McGee regarding Public Hearing Summary.

- Park, C.F. and MacDiarmid, R.A. 1975. *Ore Deposits*, published by W.H. Freeman and Company, San Francisco.
- Peterson, J. 1993. Mining Methods that Maximize Reclamation Efficiency and Minimize Costs. *In Papers of the Second EPA Placer Mine Reclamation Workshop*. U.S. EPA publication # EPA 910-R-93-015.
- Polar Mining, Inc. 1991a (October 14). Letter from Daniel May to the Reclamation Commissioner, Division of Mining, with enclosed sketches.
- Polar Mining, Inc. 1991b (December 23). 1992 Annual Placer Mining Application (Number F927278), with attached maps. Signed by Dan May, Operator, Polar Mining, Inc.
- Ray, S.R., Vohden, J. and Morgan, W. 1992. *Investigation of Trace Metals Related to Placer Mining on Fairbanks and Porcupine Creeks*. Alaska Division of Geological and Geophysical Surveys Public-data File 93-13. Fairbanks, Alaska.
- Reynolds, J.B., Simmons, R.C. and Burkholder, A.R. 1989 (June). Effects of Placer Mining Discharge on Health and Food of Arctic Grayling. *Water Resources Bulletin*: 625-635.
- Scannell, P.W. 1993. Natural Recovery of Placer Mined Streams in the Fairbanks and Circle Mining Districts: Water Quality and Fisheries Perspectives. *In Papers of the Second EPA Placer Mine Reclamation Workshop*. U.S. EPA publication # EPA 910-R-93-015.
- Silva, M. 1986. *Placer Gold Recovery Methods*. California Division of Mines and Geology. Special Publication 87. Sacramento, CA.
- Thompson, J.V. 1992 (June). Byproduct Gold From Construction Aggregates. *Engineering & Mining Journal*: 49-52.
- U.S. Department of the Army, U.S. Army Engineer District, Alaska. 1991 (December 17). Letter from Timothy R. Jennings to William D. McGee, with enclosed sketches.
- U.S. Department of the Interior, Bureau of Land Management. 1993a. Bill Lee, personal communication with Michelle Stowers, Science Applications International Corporation, June 11, 1993.
- U.S. Department of the Interior, Bureau of Land Management, Fairbanks. 1993b. Personal communication with Michelle Stowers, Science Applications International Corporation, June 14, 1993.
- U.S. Department of the Interior, Bureau of Mines. 1986. "Gold" (by J.M. Lucas). *In Minerals Yearbook, Volume I: Metals and Minerals, 1986*. Washington, DC.
- U.S. Department of the Interior, Bureau of Mines. 1988a. "Gold" (by J.M. Lucas). *In Minerals Yearbook, Volume I: Metals and Minerals, 1988*. Washington, DC.
- U.S. Department of the Interior, Bureau of Mines. 1989a. *Minerals Yearbook -- Alaska* (by T.L. Pittman). Washington, DC.
- U.S. Department of the Interior, Bureau of Mines. 1989b. *Minerals Yearbook -- Idaho* (by R.J. Minarik and V.S. Gillerman). Washington, DC.

- U.S. Department of the Interior, Bureau of Mines. 1989c. *Minerals Yearbook -- Mining Trends in the Metals and Industrial Minerals Industries* (by A.O. Tanner). Washington, DC.
- U.S. Department of the Interior, Bureau of Mines. 1989d. *Minerals Yearbook -- Montana* (by R.J. Minarik and R.B. McCulloch). Washington, DC.
- U.S. Department of the Interior, Bureau of Mines. 1989e. *Minerals Yearbook -- Nevada* (by F.V. Carrillo and J.G. Price). Washington, DC.
- U.S. Department of the Interior, Bureau of Mines. 1992a. *1991 Annual Report -- Gold* (by J.M. Lucas). Washington, DC.
- U.S. Department of the Interior, Bureau of Mines. 1992b. *Annual Report -- Survey Methods and Statistical Summary of Nonfuel Minerals* (by J.A. McClaskey and S.D. Smith). Washington, DC.
- U.S. Environmental Protection Agency. 1985a (December). *Report to Congress: Wastes From Extraction and Beneficiation of Metallic Ores, Phosphate Rock, Asbestos, Overburden from Uranium Mining, and Oil Shale*. EPA/530/SW-85-033.
- U.S. Environmental Protection Agency, Office of Water. 1985b. *Development Document for Proposed Effluent Limitations Guidelines and New Source Performance Standards for the Ore Mining and Dressing Point Source Category, Gold Placer Mine Subcategory (Draft)*.
- U.S. Environmental Protection Agency, Office of Water. 1988a (May). *Development Document for Effluent Limitations Guidelines and New Source Performance Standards for the Ore Mining and Dressing Point Source Category: Gold Placer Mine Subcategory (Final Draft)*. Washington, DC.
- U.S. Environmental Protection Agency. 1988b. *Economic Impact Analysis of Final Effluent Guidelines and Standards for the Gold Placer Mining Industry*. Office of Water Regulations and Standards. Washington, DC.
- U.S. Environmental Protection Agency. 1990a (July). *Report to Congress: Special Wastes from Mineral Processing*. EPA/530/SW-90-070C.
- U.S. Environmental Protection Agency. 1990b (November 16). *55 Federal Register 222*.
- U.S. Environmental Protection Agency. 1991 (April). *Background Document: Phase I: Regulatory Strategy For Controlling Small Commercial and Recreational Placer Mining (draft)*
- U.S. Environmental Protection Agency. 1992a (August). *Draft Industry Profile: Gold*.
- U.S. Environmental Protection Agency. 1992b (August). *Agriculture and Wetlands: A Compilation of Factsheets*. EPA 503/9-92-003.
- Van Nieuwenhuysse, E. and LaPierriere, J.D. 1986 (February). *Effects of Placer Gold Mining Effects on Primary Production in Subarctic Streams of Alaska*. *Water Resources Bulletin*: 91-99.
- Wells, J.H. 1973. *Placer Examination, Principles and Practice*. Technical Bulletin 4, U. S. Department of the Interior, Bureau of Land Management

Whiteway, P. (editor). 1990. *Mining Explained: A Guide to Prospecting and Mining*. The Northern Miner, Inc. Toronto, Ontario, Canada.

**APPENDIX 1-A**

**ACRONYMS**



## ACRONYM LIST

|         |   |
|---------|---|
| ADEC    | Alaska Department of Environmental Conservation                       |
| AMD     | acid mine drainage  |
| AWQC    | Ambient Water Quality Criteria  |
| BAT/BJP | best available technology/best professional judgment                  |
| BLM     | Bureau of Land Management   |
| BMP     | best management practice  |
| BPJ     | best professional judgment  |
| CAA     | Clean Air Act   |
| CCD     | continuous countercurrent decantation                                 |
| CERCLA  | Comprehensive Environmental Response, Compensation, and Liability Act |
| CFR     | Code of Federal Regulations   |
| CWA     | Clean Water Act   |
| DHEC    | Department of Health and Environmental Control                        |
| dscm    | dry standard cubic meter  |
| FLPMA   | Federal Land Policy and Management Act                                |
| FS      | Forest Service  |
| FWS     | Fish and Wildlife Service   |
| HDPE    | high-density polyethylene   |
| HRS     | Hazard Ranking System   |
| ICS     | individual control strategy   |
| IM      | Instruction Memorandum  |
| kg      | kilogram  |
| lb      | pound   |
| LOEL    | Lowest-Observed Effect Level  |
| MCL     | Maximum Contaminant Level   |
| mg/L    | milligrams per liter  |
| MSHA    | Mine Safety and Health Administration                                 |
| NAAQS   | National Ambient Air Quality Standards                                |
| NEPA    | National Environmental Policy Act                                     |
| NESHAP  | National Emission Standards for Hazardous Air Pollutants              |
| NIOSH   | National Institute for Occupational Safety and Health                 |
| NMEID   | New Mexico Environmental Improvement Division                         |
| NPDES   | National Pollutant Discharge Elimination System                       |
| NPL     | National Priorities List  |
| NPS     | National Park Service   |
| NSPSs   | New Source Performance Standards                                      |
| NTIS    | National Technical Information Service                                |
| oz/t    | troy ounces per ton   |
| PME     | Precision Metals Extraction, Ltd.                                     |
| ppm     | parts per million   |
| PSD     | prevention of significant deterioration                               |
| RCRA    | Resource Conservation and Recovery Act                                |
| RI/FS   | Remedial Investigation and Feasibility Study                          |
| ROD     | Record of Decision  |
| SHDG    | sediment-hosted disseminated gold                                     |
| SIP     | State Implementation Plan   |
| TSCA    | Toxic Substance Control Act   |

**ACRONYMS (Continued)**

|             |                                      |
|-------------|--------------------------------------|
| TSS         | total suspended solids               |
| <i>ug/L</i> | microgram per liter                  |
| USC         | U.S. Code                            |
| U.S. DOI    | U.S. Department of the Interior      |
| U.S. EPA    | U.S. Environmental Protection Agency |
| USGS        | United States Geological Survey      |
| VLDPE       | very low-density polyethylene        |

**APPENDIX 1-B**  
**COMMENTS SUBMITTED BY U.S. BUREAU OF MINES**  
**ON DRAFT GOLD PLACER PROFILE**

[Comments were not copied for this electronic version of the Industry Profile. Copies of the comment document may be received from U.S. EPA, Office of Solid Waste, Special Waste Branch.]

**APPENDIX 1-C**  
**RESPONSE TO COMMENTS SUBMITTED BY**  
**U.S. BUREAU OF MINES**  
**ON DRAFT GOLD PLACER PROFILE REPORT**

Response to Comments Submitted by  
U.S. Bureau of Mines  
on Draft Gold Placer Profile Report

Written comments on the placer gold mining report were received from the U.S. Bureau of Mines. Most comments were of a technical nature and were incorporated into the report. However, one comment made by the Bureau of Mines suggested that the report convert all units of measurement to the metric system (i.e., weight, length, distance, etc.). The Bureau also suggested the possibility of including both troy ounces and metric weights. Although much of the industry is moving towards metric measurements, EPA did not adopt this comment because it was felt that the units used in this report are well understood within the placer mining industry; the use of these measurements was only incidental to the purpose of this report; and the effort needed to convert them to the metric system was not warranted.

**SITE VISIT REPORTS:  
ALASKA PLACER MINES**

## **2.0 SITE VISIT REPORTS: ALASKA PLACER MINES**

### **2.1 INTRODUCTION**

This section of the Gold Placer Technical Resource Document presents summaries of three placer mining operations: Polar Mining Inc.; Alf Hopen; and Cook's Mining. EPA visited these Alaska placer sites during the summer of 1992 to gain a better understanding of typical placer operations. The site visit reports are abbreviated due to the relatively limited size of each mining operation. EPA spent approximately one-half day at each site, viewing the mining and sluicing operations.

### **2.2 POLAR MINING, INC.**

EPA visited Polar Mining's Lower Goldstream Creek operation on July 15, 1992. The following individuals participated in the site visit: Dan May of Polar Mining, Inc., Kathleen M. Charlie of the Alaska Department of Natural Resources, Steve Hoffman from EPA's Mining Waste Section, and Ingrid Rosencrantz of SAIC (EPA's contractor).

#### **2.2.1 General Facility Description**

The Polar Mining, Inc.'s Lower Goldstream operation is located on private land in Goldstream Valley, approximately 12 miles northwest of downtown Fairbanks (see Figure 2-1



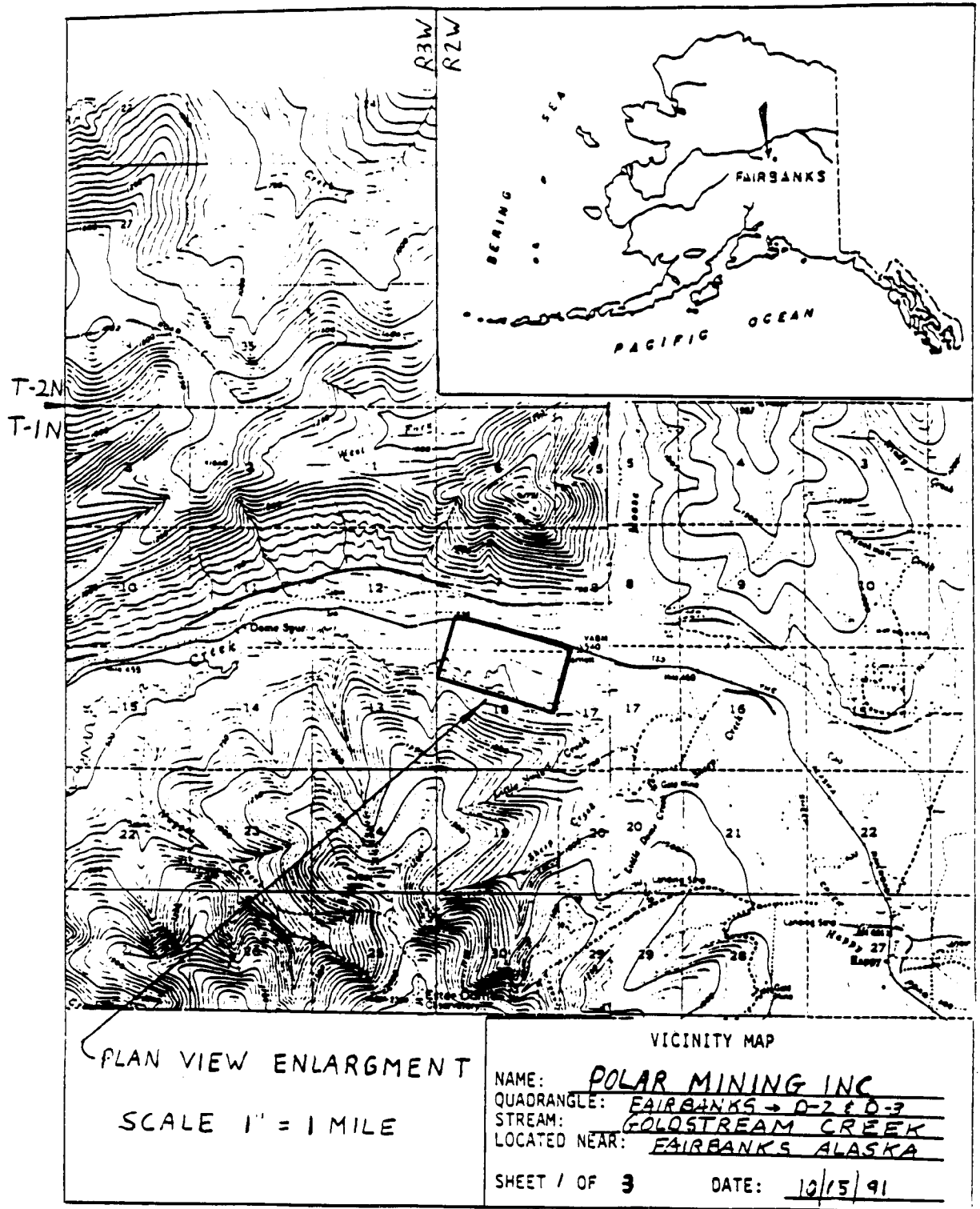

Figure 2-1. Polar Mining, Inc., Vicinity Map

(Source: Polar Mining Inc., 1992 APMA)

). Originally patented in 1938 by the Fairbanks Exploration Company, the land on which Polar Mining operates is now owned by the Alaska Gold Company (Memorandum, August 9, 1988). Donald May, founder and president of Polar Mining, owns and manages the mine, while his son Dan May acts as vice-president and maintenance supervisor for the company. Polar Mining commenced work on Goldstream Creek in 1987. The company "Overview" states that the mine employs 30 local residents 12 months a year on a monthly payroll of over \$100,000. The company also operates a gold placer mine on nearby Fish Creek. ("Overview," August 1, 1988; "Miners rig up converted Cat," April 14, 1991; Polar Mining, Inc., October 14, 1991)

Polar Mining's Lower Goldstream operation is the largest open pit placer gold mine in the Fairbanks area in 1992. The total volume of material mined in 1992, including strippings (soils presumably used for reclamation) and overburden removed, was 2,200,000 cubic yards. The estimated volume of material beneficiated during the 1992 mining season was 500,000 cubic yards. Based on this information, the stripping ratio for the Lower Goldstream operation approached 4:1 (waste:ore). The total area of the mining operation in 1992, including stripped areas, mining cuts, overburden and tailing stockpiles and disposal areas, temporary stream diversions, stream bypasses, and settling ponds, is approximately 29 acres. The estimate does not include the camp and access roads. (Polar Mining, Inc., 1992 Annual Placer Mining Application F927278)

In 1992, Polar Mining reclaimed 35 acres, both concurrently with mining and at the end of the mining season. Polar Mining reshaped the reclaimed area to blend with the surrounding physiography using tailings, strippings, and overburden. The company also stabilized the area so that it will retain sufficient moisture to allow for natural revegetation. Polar Mining spread stockpiled topsoil, overburden muck, and, if necessary, settling pond silts, over the contoured mine workings to promote natural plant growth that can reasonably be expected to revegetate the area within five years. (Polar Mining, Inc., 1992 APMA)

Unlike most placer mines, the Lower Goldstream operation was active year-round, with the possible exception of four weeks in late December and early January (Polar Mining's 1992 APMA indicates that the intended dates of operation are January 20, 1992, through December 20, 1992). Although the projected dates of operation suggest a year-round mining operation at Lower Goldstream Creek, the estimated number of sluice days for the 1992 season was 150.

The description that follows applies to the original Lower Goldstream operation as presented in an "Overview" of Polar Mining's placer mining activities in the Fairbanks area. A 1988 NPDES Compliance Inspection Report corroborates this account. During the site visit in July 1992, mining operations resembled those represented in Figure 2-2

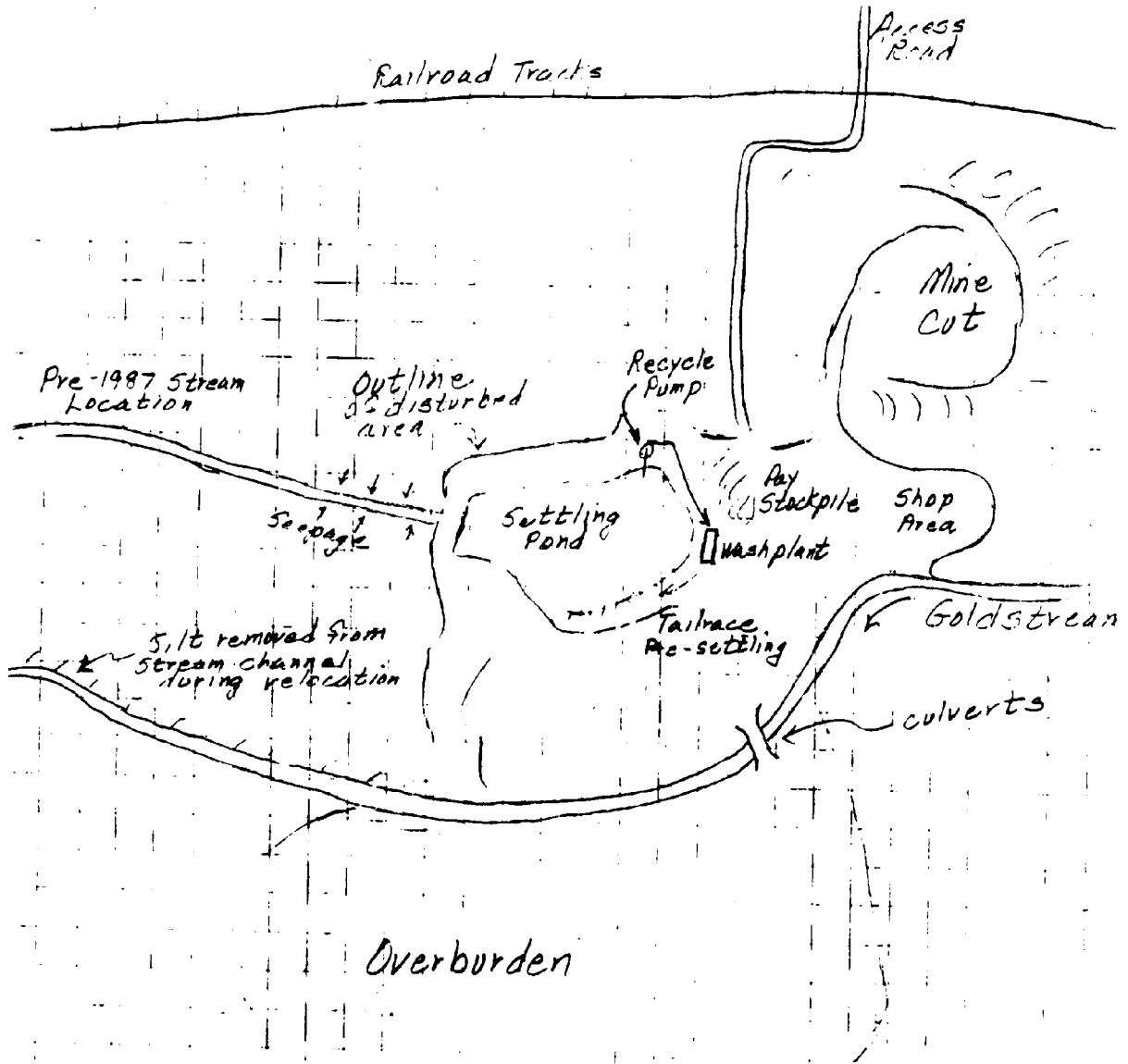

Figure 2-2. Sketch of Lower Goldstream Creek Mining Operation

(Source: ADEC, Placer Mine Inspection Form)

, only farther upstream.

During the cold winter months when the ground is frozen, Polar Mining used drilling and blasting techniques to remove frozen silt overburden, and then uses large scrapers to haul the overburden to a dump site either adjacent to the mine pit or in the immediate vicinity of the pit. According to the company "Overview," since the frozen silt overburden contains very little moisture, there is no water or mud discharge into the surrounding lowlands or Goldstream Creek when the overburden thaws in the spring. During the summer, the scrapers haul the gold placer pay gravels from the bottom of the pit to a trommel wash plant and sluice box, which is 30 feet wide by 10 feet long. Overburden from the Lower Goldstream operation consists of gravel to an average depth of 10-30 feet and organic material to an average depth of 20 feet. Total depth to pay gravel, therefore, is approximately 30-50 feet. ("Overview," August 1, 1988; Polar Mining, Inc., 1992 APMA)

Ground water entering the cut provides the source of make-up water, which is generated by seepage infiltration at an estimated volume of 10 gallons per minute. Goldstream Creek does not supply any water to the mining operation, nor does it receive any discharges. One hundred percent of the stream is bypassed by the operation, although the 1992 APMA indicates that channels are planned to connect obsolete recycle ponds to Goldstream Creek. According to the company "Overview," wash water is 100% recycled and is temporarily contained in these large recycle/settling ponds before it is transported to the recovery plant. Polar Mining did not use any chemical treatment to extract gold from the gravels. ("Overview," August 1, 1988; Polar Mining, Inc., 1992 APMA)

Before Polar Mining initiated activity at the Lower Goldstream operation in 1986, the company relocated the Goldstream Creek channel, diverting the Creek south of the original wash plant location and settling pond as they are depicted in the 1988 Placer Mine Inspection Form (see Figure 2-2). Mine cuts now follow the original streambed. At the time of the 1988 sampling inspection, Polar Mining moved overburden from the mine cut south across Goldstream Creek and stockpiled ore near the wash plant with scrapers. The wash plant facility consisted of a large trommel and a sluice box. Discharge from the sluice box is routed to a large recycle pond. According to the 1992 APMA, the recycle pond was approximately 750 feet long by 500 feet wide by 35 feet deep. A 300-horsepower pump directed the water to the wash plant through a 12-inch return line at an estimated rate of 3,500 gallons per minute. According to an internal Environmental Quality Memorandum from Paul Bateman to Pete McGee dated August 9, 1988, Polar Mining used total recycle in its operations and runs a zero discharge operation. During the 1988 site visit, however, water was being pumped from the bottom of the pit and was apparently being discharged to the tundra. During the 1992 EPA site visit, no discharges to tundra were observed. (Overview, August 1, 1988; Polar Mining, Inc., 1992 APMA)The 1992 Reclamation Plan provided for two distinct mine cuts labeled 1992-1 and 1992-2 (see Figures 2-3

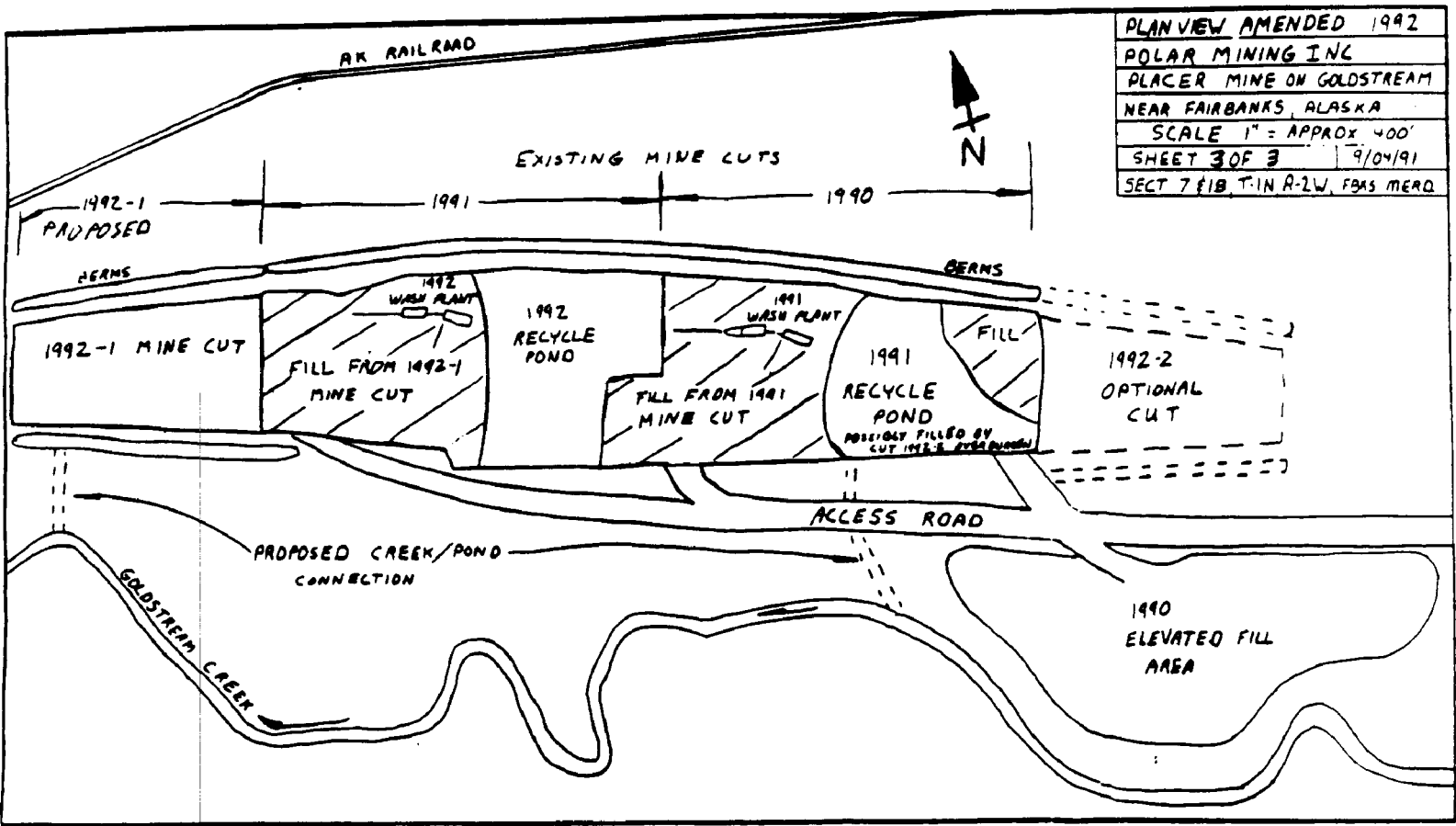

Figure 2-3. Plan View of Lower Goldstream Creek Operation, Amended 1992

(Source: Polar Mining, Inc., 1992 APMA)

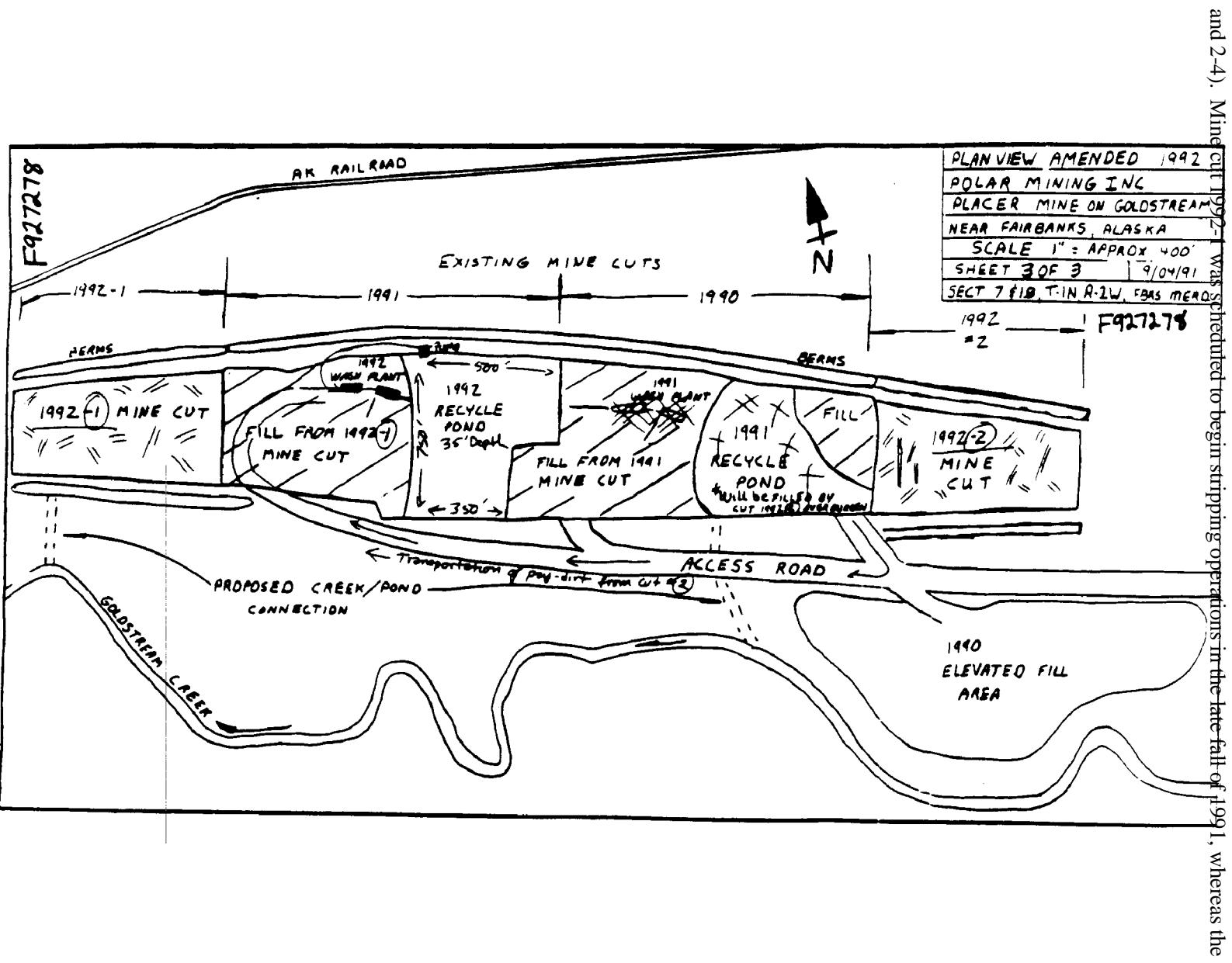

Figure 2-4. Second Plan View of Lower Goldstream Creek Operation, Amended 1992

(Source: Polar Mining, Inc., 1992 APMA)

second proposed cut was optional. (Polar Mining, Inc., October 14, 1991)

The proposed 1992-1 mine cut lies adjacent to and west of the 1991 mine cut. It is estimated to be 1,200 feet long by 450 wide by 35 feet deep, disturbing approximately 12.4 acres. Polar Mining planned to stockpile material along the north and south sides of the cut to create two topsoil/vegetation berms, disturbing an additional 2.8 acres. Each berm will each measure 1,200 feet long by 50 feet wide (at the base) by 12 feet high. Polar Mining plans to deposit the overburden removed from this cut in the 1991 mine cut, starting from the west side. A portion of the approximately 500,000 bank cubic yards<sup>1</sup> will also be used in the construction of a wide dike across the 1991 cut, dividing the cut to form a recycle pond out of the remainder of the cut. The pay gravels will be concentrated on a pad constructed on top of the dike, and the tailings that are not stockpiled for future sale will fill in the mined out cuts. (Polar Mining, Inc., October 14, 1991)

Upon completion of the 1992-1 cut, Polar Mining planned to level the berms along the north and south sides of the cut and forge a connection between the cut and Goldstream Creek, allowing the cut to fill with water and become a large pond as deep as 25 feet with at least one shallow sloping side. Polar Mining will also leave the 1992 recycle pond open after contouring the surrounding areas.

Several shallow areas in the pond will be available for waterfowl loafing and feeding. (Polar Mining, Inc., October 14, 1991)

Adjacent to the east side of the 1990 mine cut is the optional mine cut (1992-2). If mined, this cut would be approximately 1,100 feet long by 425 feet wide by 57 feet deep, covering about 10.7 acres. An additional 2.5 acres along the north and south perimeters of the cut will be stockpiled, creating topsoil/vegetation berms that measure 1,100 feet long by 50 feet wide (at the base) by 12 feet high. Polar Mining plans to deposit the overburden removed from the optional cut in the de-watered 1991 recycle pond area, completely filling it in. The remainder of the approximately 800,000 bank cubic yards of overburden would be put in the east end of the 1991 mine cut. Polar Mining would transport the pay gravels to the 1992 wash plant location and would put the tailings that are not stockpiled for future use back in the mined out cuts. Polar Mining plans to treat the 1992-2 cut like the 1992-1 cut upon completion of mining by leveling the berms and connecting the cut to Goldstream Creek. (Polar Mining, Inc., October 14, 1991)

If the optional cut (1992-2) is not mined, then Polar Mining will smooth the area around the recycle pond and connect the pond to Goldstream Creek. This pond would also have several shallow sloping areas that may render it acceptable for waterfowl habitat. (Polar Mining, Inc., October 14, 1991)

---

<sup>1</sup>A bank cubic yard is the volume of material, usually pay dirt, equivalent to one cubic yard in situ (i.e., in its original, undisturbed place in the ground). This volume does not include a swell factor or reduction in volume resulting from screening.

---

More than 10,000 gallons of fuel are stored on-site in above-ground tanks with capacities greater than 660 gallons. Fuel containment berms surround the storage containers, but the berm area was not lined. A fuel company tanker truck makes an average of 55 trips per year, transporting as much as 8,000 gallons of fuel per trip. The mine site is reached via an existing access road off Murphy Dome Road. Other equipment used on-site to facilitate overburden removal, beneficiation, and reclamation activities include two D10 dozers, one Demag H121 excavator, three 773 rock trucks, one 988B leader, one 235 excavator, one 16G grader, and a blast hole drill rig. On an annual basis, Polar Mining used 1,200,000 pounds (approximately 600 tons) of explosives to excavate, specifically ammonium nitrate fuel oil (ANFO). (Polar Mining, Inc., 1992 APMA)

In its proposed 1992 Reclamation Plan (a section of the 1992 APMA), Polar Mining projected that, given the economic conditions at the time and the mining methods being used, the company was approaching the end of the current minable ore reserve at the Lower Goldstream Creek operation. Polar Mining's plans for continued mining operations at the Lower Goldstream mine site beyond the 1992 season were unclear at the time of issuance of the 1992 Reclamation Plan. There was some discussion of a small underground operation or of continued surface mining on a much smaller scale. (Polar Mining, Inc., October 14, 1992)

### **2.2.2 Regulatory Requirements and Compliance**

Polar Mining operates its Lower Goldstream mine site with several permits. Polar Mining has been issued an NPDES Wastewater Discharge Permit (Number AK-004635-3) by EPA.

Polar Mining was first issued the Department of the Army, Corps of Engineers (COE) "404" permit (Number 4-870729) on September 30, 1988, for the placement of 4,187,100 cubic yards of dredged and fill material in 98 acres of wetlands to construct a dike, topsoil berms and overburden stockpile areas, and the placement of fill material for reclamation activities. In December 1989 Polar Mining requested that a permit modification granting authorization to move the proposed 1990 mining cut approximately one mile downstream of the area permitted for 1990 and to construct topsoil berms for the 1991 mining season. The land previously permitted for 1990 was to be left undisturbed. To facilitate ore access and subsequent reclamation activities, Polar Mining also requested authorization to create a pad from the majority of the fill material and expressed its intention to stabilize the pad when it finished mining from that cut. Polar Mining intended to use previous mine cuts as process water recycle ponds or as receiving pits for material from the next mine cut. Polar Mining stated that the pad was necessary because not all overburden could be returned to each completed excavation; overburden material has a swell factor of 30-40%. (Department of the Army, December 17, 1991)

The COE permit (Number M-870729) was modified on January 11, 1990, to allow Polar Mining to place approximately 961,100 cubic yards of dredged and fill material into approximately 19.4 acres of wetlands to stockpile topsoil and waste barren overburden for the 1990 and 1991 mining cuts. All other conditions of the original permit remained the same. (Department of the Army, August 22, 1991)



The COE permit was again modified (Number N-870729) on August 22, 1991 to extend the time limit for completing the authorized work, and the modified permit now expires September 30, 1994. (Department of the Army, August 22, 1991)

The Alaska Department of Fish and Game (ADF&G) issued Polar Mining a permit (Number FG92-III-0002), informing the company that Goldstream Creek supports resident fish species (grayling) in the area of the proposed channel excavations from the recycle pond to Goldstream Creek. The ADF&G advised Polar Mining that the excavations could obstruct the efficient passage and movement of fish. The ADF&G permit included the following stipulations to reduce potential erosion and barriers to fish passage (Alaska Department of Fish and Game, January 6, 1992):

1. The outlet channel(s) shall not be connected to Goldstream Creek prior to completion of mining-related activities in the ponds;
2. The outlet channels shall be excavated to the same depth as the bottom of Goldstream Creek where the channels enter Goldstream Creek;
3. The outlet channels shall be 12-15 feet wide at the water surface with banks graded to a stable slope; and
4. The permittee shall plug the outlet channels (with a 100-foot plug) to the original ground surface level if ADF&G identifies fish entrapment related fish kills within the ponds or potential fish entrapment related fish fills within the ponds prior to 1995.

Polar Mining does not need a permit from a state or federal land management agency to conduct its operations because the Goldstream Creek is on private land, although a permit is required from the COE for the disturbance of wetlands.

EPA is not aware of any state, federal, or local government regulations for mine noise control to the surrounding community. The Mine Health Safety Administration (MHSA), however, does regulate noise at mines to protect workers. The MHSA and the Alaska State Mine Inspector inspected the Lower Goldstream operation on June 25, 1988, and found the mine to be in compliance with all MHSA safety requirements. Winter blasting was monitored by the State Mine Inspector, who coordinated with the Pacific Powder Company to take seismic and decibel readings of each blast. The State Mine Inspector found all blasts to be within the recommended standards of noise and seismic ground shock for a residential area.

The 1988 "Overview" mentions noise-related problems at the Lower Goldstream operation. A small group of local Goldstream residents initially opposed the Lower Goldstream operation, their primary complaint being noise, but their first complaints were about visual impacts. To mitigate these impacts, Polar Mining constructed a large berm between the pit and the residential area to deflect noise away from the area homes. Polar Mining also reduced operational hours and the size of the blasts to minimize their effects. This group of Goldstream residents requested that the Alaska Department of Environmental Conservation (ADEC) hold

a public hearing on the ADEC certification of the COE permit. The public hearing was held on August 8, 1988 in Fairbanks. The issue of noise levels was raised, but most concerns involved water quality and wetlands. The State did not take any action based on this hearing ("Overview," August 1, 1988; Memorandum, August 9, 1988)

In Alaska, bonding is required for all mining operations having a mined area of five acres or greater. The area must be bonded for \$750.00 per acre, unless the miner can demonstrate that a third party contractor can do the required reclamation for less than that amount. Polar Mining submitted \$4,350.00 to the Alaska Department of Natural Resources (DNR) for payment into the State Wide Bonding Pool to meet the bonding requirements. (Polar Mining, 1992 APMA; Alaska DNR, State Wide Bond Pool Form)

According to the site manager, at the time of the 1992 EPA visit, the site was in compliance with all of its permits. (Polar Mining, 1992 APMA; Alaska DNR, State Wide Bond Pool Form)

## **2.3 ALF HOPEN**

EPA visited Alf Hopen's Little Eldorado Creek operation on July 15, 1992. The following individuals participated in the site visit: the operator Alf Hopen, Kathleen M. Charlie of the Alaska Department of Natural Resources, Steve Hoffman from EPA's Mining Waste Section, and Ingrid Rosencrantz of SAIC (EPA's contractor).

### **2.3.1 General Facility Description**

Alf Hopen operated a gold placer mine on Little Eldorado Creek in the Fairbanks mining district near Cleary, Alaska. The Little Eldorado Creek mining operation is an historic site, as evidenced by Mr. Hopen's discovery of fire pits at the site that had been used previously to thaw the layer of permafrost overlying the pay dirt. Mr. Hopen leased the land from the Alaska Gold Company and operated on both federal and private (patented) claims. The 1992 Reclamation Plan for the Little Eldorado Creek operation states that the total area to be mined in 1992 is 8 acres, excluding the camp and roads. The operator conducted reclamation on an equal amount of acreage in 1992, both concurrently with mining and at the end of the mining season. The topographical map attached to the 1992 Annual Placer Mining Application (APMA Number F925866) suggests that work is being performed at an elevation of slightly less than 1,050 feet. The site is fairly steep. Access to the mine site is by means of existing roads.

Mr. Hopen runs a seasonal operation at the Little Eldorado Creek mine site. He first started mining at this site on August 15, 1991. The planned dates of operation for the 1992 season are May 1 through October 15, with an estimated 120 sluice days during the season. Three employees work at the site. The mining operation is projected to be completed in 1992, but if work remains to be done when the season ends, then mining and reclamation activities will be finished in 1993.

During the EPA site visit on July 15, 1992, Mr. Hopen stated that he moves 1,500 cubic yards of loose material daily. He estimated that this material comprises 20-30 feet of overburden and 6-8 feet of pay dirt. The pay strip is narrow with some side pay. Overburden was pushed to the sides, while a backhoe shovelled the pay dirt to the washing plant, where classification with a shaker screen precedes sluicing. The 1992 Reclamation Plan states that the total volume of material mined, including strippings and overburden, is 70,000 cubic yards. It is unclear from the references available what the ratio is of material moved to material concentrated. The 1992 APMA estimated that during approximately 120 days, Mr. Hopen will beneficiate 600 cubic yards of material daily, which amounts to approximately 60,000 cubic yards annually. The estimates from the 1992 Reclamation Plan and APMA for total material mined and total material concentrated (70,000 cubic yards and 60,000 cubic yards, respectively) suggest a very low ratio of overburden to pay dirt. No explosives are used at this site.

The Little Eldorado Creek operation employed two sluice boxes. The larger sluice box measured 20 feet long by 4 feet wide and has a solitary channel. This sluice had 16 feet of double expanded metal riffles on nomad matting and 4 feet of hydraulic riffles that emit 4 pounds of pressure run over astroturf matting. The smaller sluice, whose dimensions are 12 feet by 34 inches, also has astroturf (door mats).

Mr. Hopen did not employ any chemical treatment in his operation. The equipment used on-site includes a D-8 and D-9 Cat bulldozer, a 980-C Cat loader, a 7/8 cubic yard Insley backhoe, a 1 1/4 cubic yard dragline, a 10x12 pump, and a 6"-pump.

Mr. Hopen had diverted Little Eldorado Creek around the mining operation. According to the 1992 APMA, the diversion ditch provides that 100 percent of the creek bypasses the mine cuts. Mr. Hopen wanted to operate with 100 percent process water recycle, but actually discharged from the fourth pond. The source of the make-up water supply is ground water gain from the cut through seepage infiltration. Make-up water was added 24-hours a day at an estimated rate of 50 gallons per minute (gpm), or 70,000 gallons per day (gpd). The Placer Plan Review Worksheet indicates that the sluice flow, which is the amount of water withdrawn, is 2,000 gallons per minute (gpm). The 1992 APMA indicates that the existing dam is 150 feet long by 15 feet high, with the width of the dam at the base measuring 50 feet and narrowing to 16 feet at the crest, but it is unclear which pond this dam blocks. The 1992 APMA indicated that Mr. Hopen's operation does not have a discharge. A narrative attachment to the 1992 APMA and sketch sheet states that settling ponds had to be built farther downstream than usual in order to create an area sufficiently wide to enable the operator to safely isolate a creek bypass with no possible future pond erosion problem. Additional settling ponds will be built in newly mined cuts as mining progresses upstream. The stream will be returned to the original channel at the end of the mining season as part of the reclamation procedures, at which time it will be permanently channeled around the settling ponds and stabilized.

There is a large percentage of rock in the tailings that will be left behind in old cuts for stream channeling as part of the reclamation plan. All discharge water will be filtered through old dredge tailings after the settling

ponds and will not go directly into the creek. The new road will be used as a dike for a temporary stream bypass. The road will be built on dragline tailings from the old open cut.

The description of the recycle/settling pond system in the 1992 APMA differs from the EPA site visit findings. It appears that the operator found it necessary to add a fourth pond to the planned three-pond system to facilitate settling so that the water would be sufficiently clear for re-use in the washing plant. The 1992 APMA (and attached sketch) indicates that the operation uses a pre-settling pond, a small pond (#1), and a larger recycle pond (#2). The site visit revealed that a pre-settling pond was not used. Instead, the main settling pond, which is 60 feet wide and 6-12 feet deep, overflowed into a smaller secondary pond below it on the hillside. The secondary pond discharges to the pump (or recycle) pond, which in turn directs water back to the wash plant for re-use. The recycle pump has 170 horsepower and feeds water through a 12"-line at an estimated rate of 2,000 gpm. In addition to these three ponds is a fourth (and final) settling pond. The Alaska Department of Environmental Conservation (ADEC) reviewed the 1992 APMA and found the water control and wastewater treatment systems adequate.

Fuel was stored onsite in tanks. Fuel containment berms surround the storage area, which were lined. A fuel truck and offsite storage vessels also function as fuel storage mechanisms. Approximately 4,600 gallons of fuel may be stored at one time. A tanker truck transports approximately 4,000 gallons per trip, and the number of trips varies. As part of clean-up, Mr. Hopen burns and buries garbage. No trash is left lying around. Waste oil is contained and removed from the mining site.

### **2.3.2 Regulatory Requirements and Compliance**

Mr. Hopen has not received any Notices of Violation (NOVs) with respect to the Little Eldorado Creek operation, nor has there yet been a Federal inspection.

Mr Hopen operates on Little Eldorado Creek with an NPDES Wastewater Discharge Permit (Number AK-004451-2) from EPA. He received a turbidity modification for the NPDES permit that was calculated using a discharge rate of 10 gpm and that permits the discharge of wastewater with a turbidity of up to 195 NTU. Discharges (seepage) greater than 10 gpm may require that the discharge be cleaner than 195 NTU during periods of low creek flow.

Mr. Hopen also has a Corps of Engineers "404" Permit Number (D-890661). ADEC declined to review or comment on the Little Eldorado Creek activity as it was proposed in the COE permit application. This non-action constituted a waiver of the state's opportunity to certify the proposed activity. Any modification to the activity could require future certification.

The Alaska Department of Fish and Game (ADF&G) reviewed the 1992 APMA and decided that a permit from ADF&G was not necessary for the proposed placer mining operation on Little Eldorado Creek. The reason given by ADF&G to substantiate this decision was as follows: "The stream is not known to support fish in the area of your proposed mining activity. Your proposed mining plan does not indicate activities will

occur in waters specified by the Commissioner as important for the spawning, rearing, or migration of anadromous fish." (Letter from Ron Somerville, Deputy Commissioner, ADF&G, to Alf Hopen, February 18, 1992)

Al Hopen submitted \$1,200 to the Alaska Department of Natural Resources (DNR) for payment into the State Wide Bonding Pool to meet the bonding requirements of Alaska Statute 27.19 for the disturbed area sketched and described in the 1992 APMA and Reclamation Plan. Bonding for Federal claims encompasses the total area of the mining operation, including the camp site, access roads, and areas to be stripped for mining during the next season. For private claims, bonding covers the active mining "footprint," which does not include the camp and access roads. It does, however, include all areas that are part of the mining operation: stripped areas, mining cuts, overburden and tailing stockpiles and disposal areas, temporary stream diversions, stream bypasses, and settling ponds.

## **2.4 COOK'S MINING**

EPA visited Cook's Mining Fairbanks Creek operation on July 15, 1992. The following individuals participated in the site visit: the operator John Cook, Kathleen M. Charlie of the Alaska Department of Natural Resources, Steve Hoffman from EPA's Mining Waste Section, and Ingrid Rosencrantz of SAIC (EPA's contractor).

### **2.4.1 General Facility Description**

Cook's Mining operated a gold placer mine located approximately 20 miles north of Fairbanks, Alaska on federal mining claims (F-52493 through F-52500) at the upper head of Fairbanks Creek, a tributary of Fish Creek, which flows into the Little Chena River. The Steese/White Mountains District of the Bureau of Land Management (BLM) is responsible for the management of this land under the General Mining Law of 1872. Patricia S. Franklin owns the claims, and John Cook operates the mine. The Upper Fairbanks Creek operation is reached by following Steese Highway north toward Cleary Summit, and then taking Fairbanks Creek Road five miles east of Cleary Summit. (Cook's Mining 1992 Annual Placer Mining Application (APMA); Alaska Department of Environmental Conservation (ADEC), December 19, 1989)

The 1992 mining season represented the fifteenth year of production at the Upper Fairbanks Creek site, and Cook's Mining anticipated that two years remain before the site will be closed. (Cook's Mining, March 31, 1992). The 1992 APMA was the source of the following general facility description.

Cook's Mining operated on a seasonal basis from approximately June 1 through October 1, employing three to four workers. The company worked an estimated 100 sluice days during the mining season. The total volume of material to be mined in 1992, including strippings and overburden to be removed, was 200,000 cubic yards. The estimated volume of material beneficiated during the 1992 mining season was 65,000 cubic yards. Based on this information, the stripping ratio for the Cook's Mining Upper Fairbanks Creek operation was approximately 3:1 (waste:ore). The total area of the mining operation in 1992, including stripped areas,

mining cuts, overburden and tailing stockpiles and disposal areas, temporary stream diversions, stream bypasses, and settling ponds, was approximately 5-6 acres. The estimate does not include the camp and access roads (Cook's Mining, 1992 APMA).

In 1992, Cook's Mining planned to reclaim 10-15 acres, both concurrently with mining and at the end of the mining season. Cook's Mining will reshape the site to blend with surrounding physiography using mine tailings and overburden. The company will spread stockpiled topsoil/organic debris over the reshaped site. Cook's Mining will ensure that fine sediment captured in the settling ponds is protected from washout and left in a stable condition at the end of the season. Finally, Cook's Mining will restore disturbed stream areas to facilitate natural restoration of fish and wildlife habitat. (ADEC, Decision Record, December 19, 1989)

Cook's Mining removed approximately 31 feet of overburden, consisting of 30 feet of gravel and one foot of organic material. Cook's Mining then fed the pay gravels to a trommel wash plant and sluice box, which measures 24 feet long by four feet wide and has three channels with a 2:1 slope. Cook's Mining concentrates an estimated 700 cubic yards of material daily. No chemical treatment is used at the Upper Fairbanks Creek operation. (Cook's Mining, 1992 APMA)

Ground-water gain from the mine cut and Fairbanks Creek supply the make-up water. Stream flow at this point in the valley is 300 to 400 gallons per minute, while ground-water infiltration can add another 50 gallons per minute. The Fairbanks Creek operation has an intermittent, variable discharge. When Cook's Mining began sluicing for a new cut, it can take up to two weeks for the stream to fill a new recycle pond. Until the pond fills, there is no discharge; after it fills, there is a discharge of 300-400 gallons per minute, 24 hours a day, seven days a week.

The operation is near the head of the valley where the stream runs at a low volume. Cook's Mining needs the stream flow as make-up water for the ponds to keep up with the outgoing pond seepage that would diminish the reservoirs if the company diverted the stream around the mine site. However, Cook's Mining tried to divert the stream to one side of the cut or the other whenever it is feasible so that the equipment does not run in the stream while mining activities are in progress. Since the valley is extremely narrow and has steep sides, Cook's Mining cannot make the stream fully bypass the mining cut or ponds without constructing a large, expensive notch along the length of the south side of the valley, which would destroy the hillside and would not serve any practical purpose. The quality of the water discharge from the mine site has been good enough that Cook's Mining does not find it necessary to construct such a drastic stream bypass. Fairbanks Creek filters through several miles of dredge tailings downstream from the Cook's Mining operation, then emerges again as surface flow. (Cook's Mining, attachment to 1992 APMA; Cook's Mining, "Mining Plans," 1987)

As the mining operations advance, the valley narrows, and the wet groundcover associated with the bottom of the valley diminishes. As of March 31, 1992, approximately 40 feet of valley bottom width was considered wet groundcover. Cook's Mining removed this material and stacked it on the hillside to form an overburden pile 75 feet wide by 1,800 feet long, by 40 feet high. (Cook's Mining, March 31, 1992)

Cook's Mining operated two pay channels in this valley, one being the lower channel previously described as having 40 feet of wet groundcover. Cook's Mining was uncovering a bench deposit on the north slope of the valley. This is a very dry hillside area, and the overburden that is removed from this bench is pushed directly into the previous bench cut that was just mined. Dry material is therefore being pushed into a dry hole in the hillside far from the bottom of the valley. (Cook's Mining, March 31, 1992)

Ponds were planned for the lowest point of the valley on the cleaned bedrock, and six berms will line the ponds and measure 100 feet long, by 45 feet wide, by 25 feet tall. Cook's Mining will build these berms using the material previously accounted for in the overburden piles stacked along the side of the cut on the south side of the valley. (Cook's Mining, March 31, 1992)

The recycle/settling pond system had been built in mining cuts behind the most current operation as it progresses up the valley. Each pond differs from the others because the overburden from new cuts is deposited in previous cuts, and then the company builds settling ponds from the area available after it finishes stripping the cuts. Although the ponds vary significantly, an average set of dimensions for one of Cook's Mining's settling ponds is 200 feet long by 100 feet wide by 30 feet deep. The recycle pump is a 60-horsepower instrument that sends an estimated 800 gallons per minute of water through an 8-inch return line.

There is at least one existing dam and at least one more dam to be constructed. The existing dam is described as being 150 feet long and 30-50 feet high. The width of the dam is 40 feet at the crest and 75-100 feet at the base.

Approximately 3,000 gallons of fuel are stored on-site in tanks with capacities larger than 660 gallons and in a tanker on wheels. Fuel containment berms do not surround the fuel storage containers. A truck from town transports approximately 2,500 gallons of fuel on each of its 10 trips to the site.

Cook's Mining uses the following equipment to accomplish the tasks described: two John Deere 850 dozers to strip and push pay dirt; one Cat 225 excavator to divert the stream, prospect, and sluice; one John Deere 444 rubber tire loader to move tailings; one D9L Cat dozer for stripping; and miscellaneous trucks, pumps, and generators to support the stripping and sluicing activities.

#### **2.4.2 Regulatory Requirements and Compliance**

Cook's Mining had an NPDES permit (Number AK-004632-9) from EPA. EPA granted Cook's Mining a turbidity modification that allows the company to discharge waste water with a turbidity of up to 16 nephelometric turbidity units (NTU), a modification that was calculated using a discharge rate of 50 gallons per minute. Seepage greater than 50 gallons per minute could require Cook's Mining to maintain a discharge cleaner than 16 NTU during periods of low creek flow. (ADEC, April 7, 1992) Since Fairbanks Creek is not known to support fish in the area of the Cook's Mining operation, the Alaska Department of Fish and Game (ADF&G) did not require a permit.

In Alaska, bonding is required for all mining operations having a mined area of five acres or greater. The area must be bonded for \$750.00 per acre, unless the miner can demonstrate that a third party contractor can do the required reclamation for less than that amount. Cook's Mining submitted \$2,250.00 to the Alaska Department of Natural Resources (DNR) for payment into the State Wide Bonding Pool to meet the bonding requirements. (Cook's Mining, 1992 APMA; Alaska DNR, State Wide Bond Pool Form)

## **2.5 REFERENCES**

Alaska Annual Placer Mining Application, with attachments, February 3, 1992.

Alaska Placer Plan Review Worksheet, April 3, 1992.

Alaska Department of Environmental Conservation. 1992a (March 20). Letter from William D. McGee, Alaska Department of Environmental Conservation, to Alf Hopen.

Alaska Department of Environmental Conservation. 1992b (April 7). Letter from William D. Morgan, Alaska Department of Environmental Conservation, to Alf Hopen.

Alaska Department of Environmental Conservation. 1992c (April 7). Letter from William D. Morgan to John Cook, Cook's Mining.

Alaska Department of Environmental Conservation. December 19, 1989. Decision Record, with attachments.

Alaska Department of Environmental Conservation. June 3, 1988. Placer Mine Inspection Form, with an EPA NPDES Compliance Inspection Report cover sheet dated August 2, 1988 and signed by Conrad Christianson.

Alaska Department of Fish and Game. 1992a (January 6). Letter to Dan May, Polar Mining, Inc.

Alaska Department of Fish and Game. 1992b (February 18). Letter from Ron Somerville, Alaska Department of Fish and Game, to Alf Hopen.

Alaska Division of Mining Approved Reclamation Plan, approved by John E. Wood, May 6, 1992.

Alaska Department of Natural Resources Case File Abstract, February 21, 1992.

Alaska Department of Natural Resources State Wide Bond Pool Form, April 27, 1992.

Alaska Department of Natural Resources. 1988 (August 1). "Overview: Polar Mining, Inc." An executive summary of the Lower Goldstream operation faxed from the Alaska Department of Natural Resources.

Cook's Mining. 1987. "Mining Plans." Letter from John Cook; recipient unknown.

Cook's Mining. 1992a (January 6). 1992 Annual Placer Mining Application (Number F926973), with attachments. Submitted to the Alaska Department of Environmental Conservation by John Cook.

Cook's Mining. 1992b (March 31). Letter from John Cook to Kevin Morgan, Department of the Army.



Memorandum. August 9, 1988. From Paul Bateman to Pete McGee regarding Public Hearing Summary.

Polar Mining, Inc., 1992 Annual Placer Mining Application (Number F927278), with attached maps.  
December 23, 1991. Signed by Dan May, Operator, Polar Mining, Inc.

Polar Mining, Inc. October 14, 1991. Letter from Daniel May to the Reclamation Commissioner, Division of Mining, with enclosed sketches.

United States Department of the Interior, Bureau of Land Management. Environmental Assessment (EA Log Number AK-080-89-041).

U.S. Department of the Army, U.S. Army Engineer District, Alaska. 1991 (August 22). Permit modification issued by Timothy R. Jennings to Polar Mining, Inc.

U.S. Department of the Army. December 17, 1991. Letter from Timothy R. Jennings to William D. McGee, with enclosed sketches.

**SITE VISIT REPORT:**  
**VALDEZ CREEK MINE**  
**CAMBIOR ALASKA INCORPORATED**

**US EPA ARCHIVE DOCUMENT**

### 3.0 SITE VISIT REPORT: VALDEZ CREEK MINE CAMBIOR ALASKA INCORPORATED

#### 3.1 INTRODUCTION

##### 3.1.1 Background

The U.S. Environmental Protection Agency (EPA) is currently developing a mining program under the Resource Conservation and Recovery Act (RCRA). To date, EPA has initiated several information gathering activities to characterize mining wastes and mining waste management practices. EPA has also chartered a Policy Dialogue Committee under the Federal Advisory Committee Act to encourage discussion of mining-related issues by representatives of EPA and other Federal agencies, States, industry, and public interest groups. As part of these ongoing efforts, EPA is gathering data related to waste generation and management practices by conducting visits to mine sites. As one of several site visits, EPA visited the Valdez Creek Mine on July 13, 1992.

Sites to be visited were selected by EPA to represent both an array of mining industry sectors and different regional geographies. All site visits have been conducted pursuant to RCRA Sections 3001 and 3007 information collection authorities. When sites have been on Federal land, EPA has invited representatives of the land management agencies (Forest Service/Bureau of Land Management). State agency representatives and EPA regional personnel have also been invited to participate in each site visit.

For each site, EPA has collected information using a three-step approach: (1) contacting the facility by telephone to get initial information, (2) contacting state regulatory agencies by telephone to get further information, and (3) conducting the actual site visit. Information collection prior to the site visit is then reviewed and confirmed at the site.

In preparing this report, EPA collected information from a variety of sources including Cambior Inc., and the State of Alaska. The following individuals participated in the Valdez Creek Mine site visit on July 13, 1992:

Cambior Alaska, Incorporated

Bob Walish, General Manager  
907-694-4653

U.S. Environmental Protection Agency

Steve Hoffman, Chief, Mine Waste Section, Office of Solid Waste  
703-308-8413

Science Applications International Corporation

Ingrid Rosencrantz, Environmental Scientist  
703-734-2508

#### 3.1.1.1 General Description

The Valdez Creek Mine was the largest placer gold mine in North America in 1992 and is operated by Cambior Alaska, Incorporated. The operation is owned by Camindex Mines (25 percent share holder) and Cambior Alaska, Incorporated (75 percent share holder). The operation is located near Cantwell, Alaska, 110 miles south of Fairbanks, along the Denali Highway (Figure 3-1)

US EPA ARCHIVE DOCUMENT

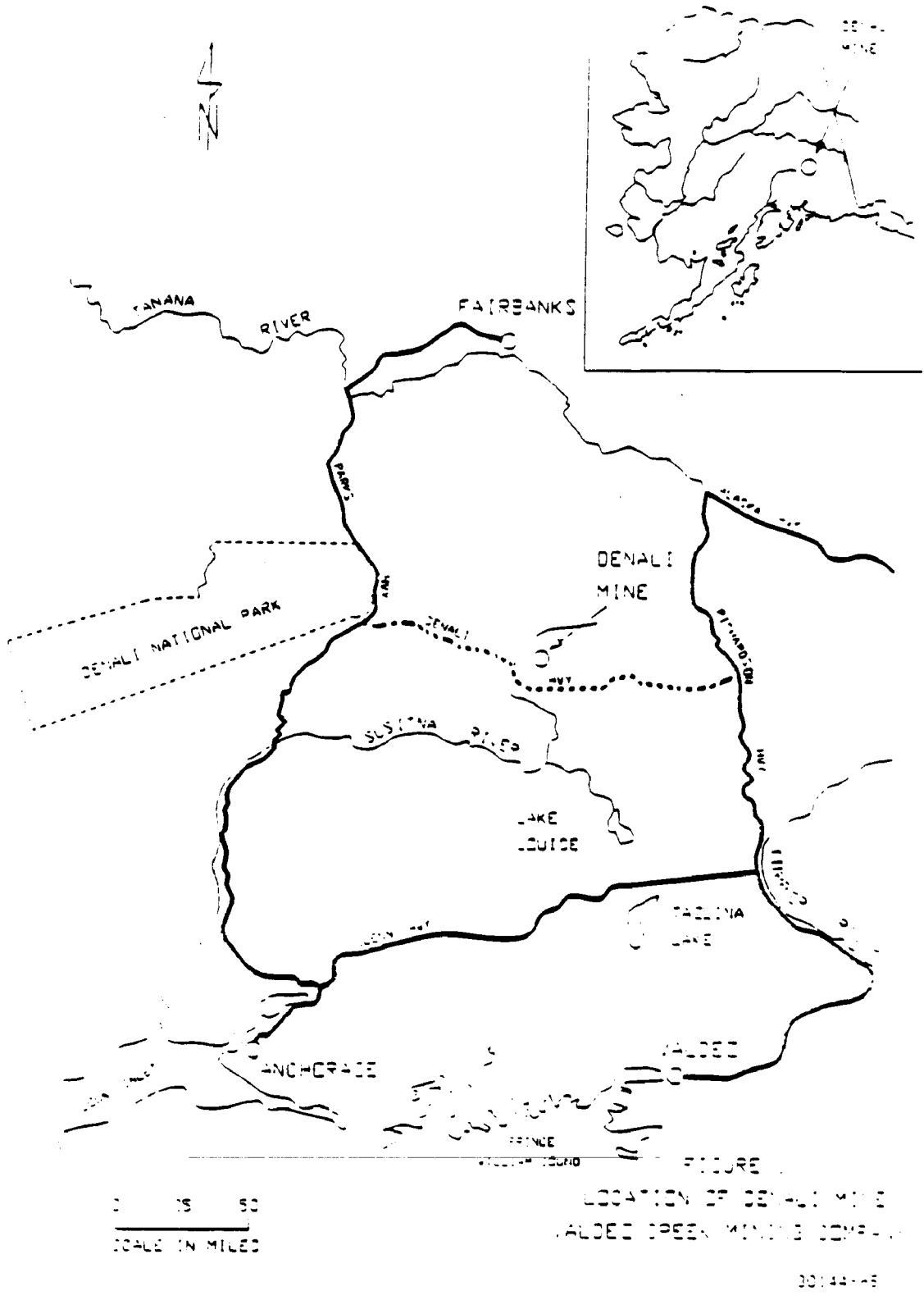

Figure 3-1. Facility Location Map

(Source: Environmental Assessment 1990)

The mine extracted loosely consolidated alluvial material from the valley bottom to a depth of 180 to 200 feet. Gold bearing pay-gravel is passed through a wash plant (a sluice system) to gravity concentrate the gold. Additional gold concentration is conducted using a jig, Knudsen bowl and magnetic separation.

Typically, pay-gravels have been located in deeply-buried paleochannels north of the active channel of Valdez Creek. However, in the area where mining was taking place, the active channel of Valdez Creek converges with the area to be mined, overlying the paleochannels. In order to access portions of the mine, the facility had diverted Valdez Creek around the mine. Diversion structures include a diversion dam, spillway and ditch.

The facility held placer mining claims in the area that cover 19,880 non-contiguous acres of Federal Land under jurisdiction of the Bureau of Land Management. According to facility personnel, the most recent active operations are currently disturbing approximately 67 new acres of BLM land, not including land previously disturbed. As shown in Figure 3-2

| AREA | USE                | ACREAGE | RECONSTRUCTION | PLANT |
|------|--------------------|---------|----------------|-------|
| A    | DOCK PIT           | 6.0     | 90             | 90    |
| B    | DETELLING PONDS    | 14.2    |                |       |
| C    | TAILINGS AREA      | 9.6     |                |       |
| D    | CAMP & STORES      | 10.2    | 87             | 88    |
| E    | TAMMANY CUT        | 7.3     | 89             | 90    |
| F    | ROADS, WASTE AREAS | 5.0     | 89             | 89    |
| G    | A-2 WASTE          | 13.2    | 86             | 87    |
| H    | PL-PIT             | 10.9    | 89             | 90    |
| I    | PL- WASTE          | 5.3     | 88             | 89    |
| J    | A-2 WASTE          | 6.9     | 87             | 87    |
| K    | A-2 PIT            | 10.2    | 90             | 91    |
| L    | A-2 WASTE          | 14.9    | 86-87          | 88    |
| M    | A-3, A-4 WASTE     | 22.2    | 88             | 88    |
| N    | STAGING AREA       | 18.8    | 88             | 89    |
| O    | PIT A-4            | 7.9     | 89             | 89    |
| P    | PIT A-3            | 16.9    | 89             | 89    |
| Q    | A-3 WASTE          | 26.8    | 89             | 89    |
| R    | PIT A-3 ext        | 4.0     | 89             | 89    |
| S    | A-5 WASTE          | 12.9    | 88             | 88    |
| T    | PIT A-5            | 21.6    | 90             | 90    |
| U    | PIT A-6            | 45.0    | 91             | 91    |
| V    | PIT A-7            | 44.6    | 91             | 91    |
| W1   | DIVERSION          | 26.6    | 92             | 92    |
| W2   | DIVERSION          | 40.1    | 92             | 92    |

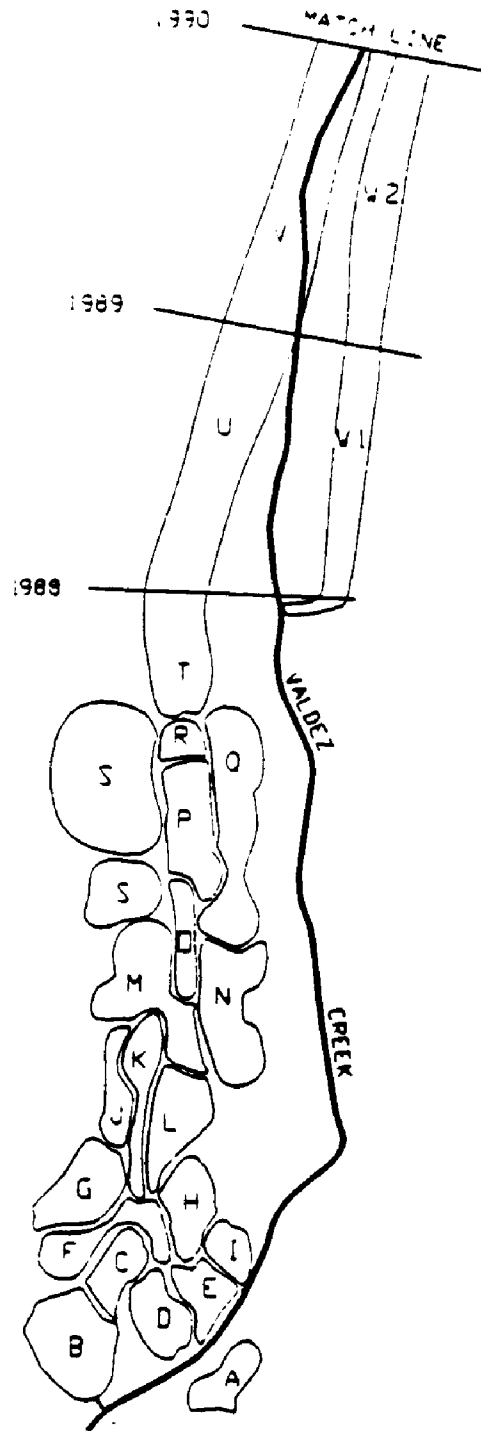

FIGURE 1  
 DENALI MINE WORK AREAS  
 VALDEZ CREEK MINING COMPANY  
 SHEET 1 OF 2

0 1000 2000  
  
 SCALE IN FEET

30144-60

Figure 3-2. Denali Mine Work Areas

(Source: Valdez Creek Mining Company, Plan of Operations)

| AREA | USE               | SURFACE | START/END YEAR | STATUS |
|------|-------------------|---------|----------------|--------|
| V3   | DIVERSION         | 23 0    |                | 99     |
| V4   | DIVERSION         | 28 8    |                | 99     |
| V5   | DIVERSION         | 27 4    |                | 92     |
| V6   | DIVERSION         | 100 0   |                | 92     |
| X    | PIT A-8           | 70 2    | 92             | 92     |
| Y    | PIT A-9           | 80 3    | 92-93          | 93     |
| Z    | PIT A-10          | 97 2    | 93*            | 93*    |
| *    | SUBJECT TO REVIEW |         |                |        |

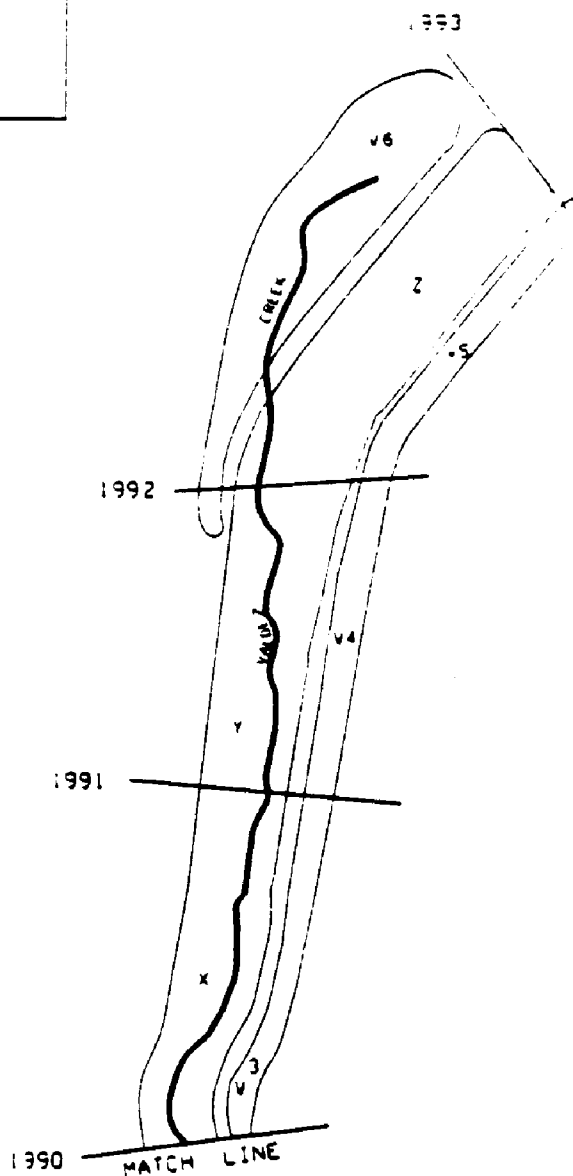

DENALI MINE WORK AREAS  
 VALDEZ CREEK MINING COMPANY  
 SHEET 2 OF 2

0 1000 2000  
 SCALE IN FEET

30144-61

Figure 3-2. Denali Mine Work Areas (continued)

(Source: Valdez Creek Mining Company, Plan of Operations)



, the total area of land disturbed at the mine, including past mining activity, is on the order of 807 acres (BLM 1990). In addition to Valdez Creek Mine, there are other smaller mines further up the Valdez Creek valley.

Open pit mining began at the site in 1984. Cambior Incorporated purchased the existing mining operations in November 1989 and shut down the operation in November 1990 to construct a new wash plant and settling/tailings impoundments (Cambior, 1991). According to facility personnel, the operation reopened in August 1990, with mining in the A7 pit beginning in March 1991.

Mining began in the area in 1903, with the discovery of placer deposits. After a small "rush" in 1904 and 1905, mining activity in the area was variable with techniques such as drift mining, booming and hydraulicking used to access and excavate the pay dirt. According to the Environmental Assessment, three different mining companies held the Valdez Creek property from 1913 to 1949 and conducted a considerable amount of mining. Mining in the area was substantially reduced until open pit mining began in 1984.

### **3.1.2 Environmental Setting**

The mine is located in the Clearwater Mountains area, part of the Alaska Range. Valleys in the region were occupied by the Susitna, West Fork, and Valdez Creek glaciers during past periods of glaciation. Glacial features in the valley include medial, lateral, end, and ground moraines. Valdez Creek is a tributary to the Susitna River; the Susitna River flows into the Cook inlet on the south coast of Alaska. The mine is located at approximately 3,000 above sea level. The climate is harsh during most of the year, with extreme cold conditions from October through April or May. Temperatures range from summers highs in the 50's to winter lows in the -40's range (Valdez Creek Mining Co. 1988) Mean annual precipitation is estimated to be between 10 and 12 inches per year. Most of this falls as snow from February through May. The Environmental Assessment (BLM 1990) estimated that up to 9 inches of the annual precipitation budget (12 inches) is lost by sublimation and evapotranspiration, and that 2.4 inches run off via Valdez Creek, the remainder recharges ground water.

Vegetation is typical of cold climate species. In the valley bottom, conifers (scattered black spruce) are mixed with grasses and alder. Further up the valley slopes, the vegetation grades into tundra species including dwarf birch, mountain avens, dwarf willows, cranberry, and other species. There are no threatened or endangered plant species in the area. (BLM 1990)

Wildlife in the area include caribou, moose, wolf, black and brown bear, fox, and beaver. None of these species occur in large numbers and according to site personnel, no threatened or endangered species occur in the area. Valdez Creek supports populations of grayling and lake trout. The stream diversion required to conduct mining activity in pits A-7 through A-10 resulted in the operator having to transport the fish around the diversion. Grayling migrate upstream in the spring, following breakup, for spawning. The fish are captured in a pool located below the mine and are trucked a short distance up stream. (BLM 1990)

#### **3.1.2.1 Geology**

The geology at the site consists of poorly-sorted glacial and fluvial material deposited above bedrock. The sedimentary deposits consist of glacially worked alluvial and fluvial sediments deposited by the Susitna, West Fork and Valdez glaciers during past glaciation (Valdez Creek Mining Co. 1988). Material from volcanic ash outfalls are also present in the area.

The site contains paleochannels cut during interglacial periods by the ancestral Valdez Creek. These channels contain the sediments (fluvial deposits) where placer gold material has been naturally concentrated (Figure 3-3

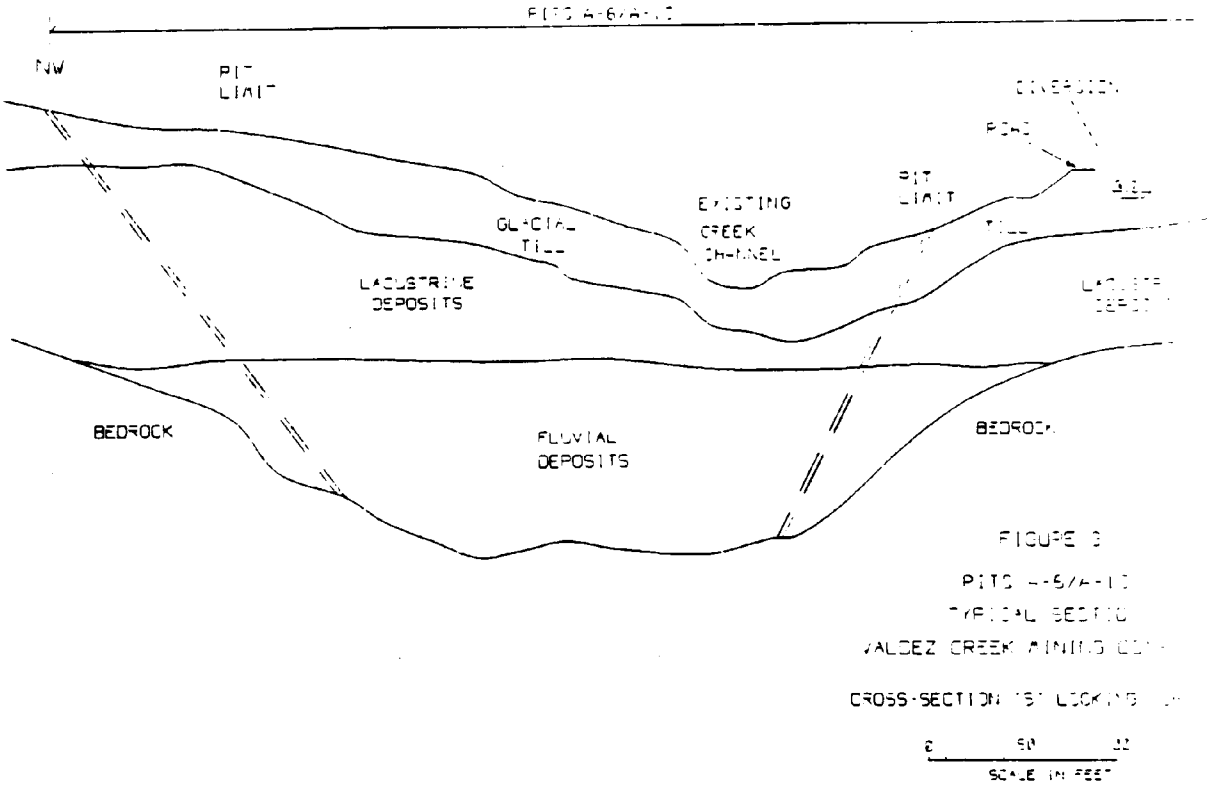

Figure 3-3. Typical Cross Section of Pits A-6 Through A-10

(Source: Valdez Creek Mining Company, Plan of Operations)

). This material is sometimes referred to as pay-gravel or pay-dirt. Overlying these are the lacustrine and outwash features characteristic of a glacial environment. Height of the section above bedrock averages 200 feet.

There are two pay gravel deposits mined at the site. The main deposit conforms to the bedrock floor and is approximately 20 feet thick, while a second newer deposit is in a canyon incised in the main deposit that reaches an additional depth of 40 feet. Where possible, both deposits are mined; however, the difficulty of delineating the newer deposit because of its irregular channel path often results in leaving the deposit unmined.

Soils are typical of cold climates at high altitudes and latitudes. Dominant soils are Histic and Pergelic Cryaquepts that are wet during the summer. Soils are prone to high runoff and erosion because they have a low permeability and slopes in the Valdez Creek valley are high. Topsoil in the area is very shallow and generally nutrient deficient. Although permafrost does occur in the area, none has been encountered at the Denali Mine (BLM 1990).

#### 3.1.2.2 Surface Water

The Valdez Creek valley watershed covers an area of 60 square miles. The Creek flows 17 miles from Grogg Lake to the Susitna River. Mining operations are concentrated on the lower portion of the valley, two miles upstream from the Susitna River. In this area, Valdez Creek has been diverted by the mining company in order to access to ore beneath the active stream channel (see Section 3.2). A diversion dam has been constructed upstream of the active pit. The dam impounds water, which then flows through the diversion channel approximately one mile until rejoining with the stream. The diversion channel is lined and covered with rip-rap. The Creek is then returned to its original channel below the mine, before entering the Susitna River. In addition to the Creek diversion system, the facility has two small diversion ditches on either side of the valley to intercept runoff before it reaches the pit. Water from these diversion ditches flows to two settling ponds.

Over most of its course, Valdez Creek flows as a single, confined channel. The channel is braided above the diversion dam and then from below the mine to its confluence with the Susitna River. Background water quality tests in the stream show a turbidity of 0.4 nephelometric turbidity units (NTU), with settleable solids of less than 0.1 ml/l. Storm runoff can increase these levels to 1,500 NTU, with settleable solids reaching 10.3 ml/l. (BLM 1990)

Discharge from the Creek is estimated to be 300 cubic feet per second (cfs) in late March and up to 900 cfs in late May and early June. The 25-year flood is estimated to flow at 2,700 cfs. All of the facilities are within the 100-year floodplain. (BLM 1990)

#### 3.1.2.3 Ground Water

As discussed above in the geology section, the site is underlain by unconsolidated glacial and fluvial material above bedrock. Till is interbedded with lenses of gravel in the upper portions of the profile that discharge an estimated 10 to 30 gallons per minute (gpm) of ground water. In the area just above the bedrock, a 10 foot zone of gravel, cobbles, and boulders discharge up to 50 gpm. (BLM 1990) Transmissivity in the till is estimated to be approximately  $10^{-5}$  cm/sec (Valdez Creek Mining Co. 1988). According to the facility's Solid Waste Permit Application, the regional water table is a ten or more feet into the bedrock, 170 to 200 feet below the surface and water production is limited. Additional information concerning the hydrologic regime at the site was not obtained.

The facility operated eight dewatering wells that pump ground water from the area prior to and during mining. According to facility personnel, five wells are located above the diversion dam, which is upstream of the active pit, and 3 wells are located below the dam in the mine area. The water was discharged to the diversion system directly below the diversion dam. Additional information on these 8 dewatering wells was not obtained.

The facility operated three drinking water wells onsite. Wells A and B provided less than 10 gallons per minute and were used during normal operations. Well C was only used during winter operations. Well water was tested monthly for coliform, quarterly for volatile organics and once every 4 years for gross  $\alpha$ . Depths of these wells and results of the testing were not obtained.

## **3.2 FACILITY OPERATION**

### **3.2.1 General Overview**

Cambior's Valdez Creek Mine recovered over 75,000 ounces of gold annually, making it the largest placer operation in North America in 1992. Reserves are estimated to be 216,843 raw ounces with grades that average 0.1 ounces per cubic yard. Typically, mining progressed up the valley, with ore hauled by truck to a wash plant for gravity concentration and waste rock trucked to backfill previously excavated pits. The Plan of Operations for the period from 1990 to 1994 called for moving 35,590,000 cubic yards of overburden to access 4,450,000 cubic yards of pay gravel.

According to Cambior personnel, the Company employed 155 people onsite and operated 365 days each year. Two shifts ran each day for 10.5 hours. Three crews cycle in and out: 14 days on, one week off. Accommodations for the crews are ATCO trailers purchased from the Alyeska Company, where they were used along the Trans-Alaska Pipeline. Some employees prefer to live offsite in a camp on BLM land close to the facility referred to as Little Idaho. Water, sewage, and electricity is supplied by the facility.

### **3.2.2 Extraction**

As discussed above, open pit mining of paleochannels north of Valdez Creek began in 1984. Camindex Mines has been a partial owner since the start of the project (at various percentages). Cambior acquired a 26

percent share of the mine in 1989, 49 percent in May 1990, and, effective January 1991, the ownership is: Cambior 75 percent, Camindex 25 percent. In August 1990 the operators shut down the operation to make operational changes. Until then, pay-gravels had been located in deeply-buried paleochannels separate from the active channel of Valdez Creek. However, as mining progressed up-valley, the paleochannels converged with the active channel of Valdez Creek. In order to access the ore, the facility constructed a diversion system for Valdez Creek. During this same inactive period, the facility also constructed a new wash plant and settling impoundments. Upon completion of construction in March 1991, mining began again with excavation from Pit A7.

#### 3.2.2.1 Excavation

The Operating Plan for 1990 through 1994 laid out the progression of mining activities. Figure 3-2 is a plan view of pit, waste, tailing, and facility building locations. The acreage for each use is identified, total area for all the activities identified is 807 acres. The operation was mining in the area A-7 (labeled area V and located at the top of the figure), and continuing upstream through A-10. Table 3-1

**Table 3-1. Estimated Volumes of Overburden and Pay-Gravel**  
 (Source: Valdez Creek Mining Company, Plan of Operations)

**MASS BALANCE**

**DENALI MINE 1990-94**

| PIT NAME                | DC-1 | A-7  | A-8  | A-9  | A-10 | Totals |
|-------------------------|------|------|------|------|------|--------|
| Acreage                 | 6    | 67.3 | 70.2 | 80.2 | 22.3 | 246    |
| Overburden<br>Cu. Yd.*  | 640  | 9100 | 9100 | 8250 | 8500 | 35590  |
| Pay Gravels<br>Cu. Yd.* | 110  | 700  | 740  | 1600 | 1300 | 4450   |

\* In thousands

provides the estimated volume of overburden and pay gravels in each of these areas.

Pit A7 was being mined in 10 phases, with 2 or 3 phases in operation at any one time. Each phase of the current pit is 400 to 650 feet wide (in the direction perpendicular to the stream channel), 180 to 200 feet deep, and 400 to 600 feet long.

At any one time, there was approximately 1,200 feet of open cut (e.g., a 1,200 foot length of valley bottom, 400-650 foot wide) being mined and backfilled. The top 180 feet of material is waste rock with pay gravel reaching a depth of 20 feet below the waste rock. The facility was extracting an average of approximately 34,000 cubic yards of material each day. Of this, 3,000 cubic yards pass through the wash plant when it is operating, leaving approximately 90 percent of the material moved as waste.

There were two pay gravel deposits in the area of Pit A7. The main deposit conforms to the bedrock floor, while a second newer deposit is in a canyon incised in the main deposit that reaches an additional depth of 40 feet. Where possible, both deposits are mined; however, the difficulty of delineating the newer deposit because of its irregular channel path often results in leaving the deposit unmined.

Initially the area was dewatered by pumping from withdrawal wells located near the diversion dam. Before excavating, a new section is drilled and blasted using ANFO to loosen or "fluff up" the unconsolidated material thereby making it easier to load and haul. The Company purchased ammonium nitrate and mixes it with fuel oil onsite. Waste rock is then mucked up and trucked to previously mined pits for disposal. The company used two front shovels, one with a 13-yard<sup>3</sup> bucket and one with a 11-yard<sup>3</sup> bucket and a Caterpillar front-end loader with a 12-yard<sup>3</sup> bucket to muck waste rock, and eight 85-ton Caterpillar trucks to haul the waste rock. Pay gravel was mucked with a backhoe having either a six-yard<sup>3</sup> or nine-yard<sup>3</sup> bucket and trucked to the wash plant. Usually smaller 50 ton trucks are used to haul pay dirt. The facility also used four dozers to work the dumps and the roadways.

#### 3.2.2.2 Water Management

During the site visit, EPA observed water in the bottom of the pit and noted the plasticity of the soils as trucks traveled in the area. According to facility personnel this is due to characteristics of the glacial till overburden. To help with water management in the active area of the pit, the facility maintained two small diversion ditches on either side of the valley above the mined area to intercept runoff before it reaches the pit. In addition, the area to be mined was dewatered by eight ground water wells. Water from these wells is pumped to the diversion channel. According to facility personnel, five wells are located above the diversion dam above the mine and three wells are located below the dam. The water was discharged to the diversion system directly below the dam. Additional information on these eight dewatering wells was not obtained.

To access pay-gravels in pits A-7 through A-10 a temporary stream diversion was built. According to facility personnel, the diversion dam, is approximately 200 feet wide and over 25 feet tall with a crest width of approximately 50 feet (the dam was observed during the site visit). The area impounded during breakup



reaches a maximum of approximately 100 acres, two to three times the normal impoundment size of 25 acres. Typically, the water is only a few feet deep; however at breakup it may reach 10 feet in depth. The diversion ditch leads approximately 5,000 feet downhill, from the diversion dam to where it discharges to the creek. The entire diversion ditch is lined with a synthetic liner and rip-rap to prevent erosion and downcutting.

Peratrovich, Nottingham & Drage, Inc. were retained to prepare an engineering study for the diversion. The final design allowed a two stage implementation. Stream flow would be diverted to a channel 500 feet south and parallel to the natural stream. The stage I channel would be 5,385 feet long and the stage II channel would be 5,385 feet long for a total length of 10,755 feet. The channel invert was planned to be 20 feet wide at the base and 30 feet wide to the top and 2 to 2.5 feet deep. The diversion channel was to be designed to accommodate flow up to 2,700 cfs, equivalent to the 25 year flood event. Average flow is expected to be 700 cfs.

### 3.2.3 Beneficiation

The wash plant that concentrates the gold is strictly a mechanical system, no chemical additives were used. Additional gold concentration is conducted in a guarded and secured room using a jig, Knudsen bowl, table, and magnetic separation.

Pay-gravel was delivered to the wash plant by truck and dumped into a vibrating grizzly feeder. Water is added to the grizzly through pipe-mounted sprayer heads at the rate of 1,500 gallons per minute. The grizzly discards material larger than six inches in diameter. Material less than six inches in diameter passes to double-deck vibrating screens. Additional water is added to the screens at the rate of approximately 1,500 gallons per minute. The screens reject material larger than 3/4 inches in diameter. This material is carried by conveyor to a pile and is used by the facility for road repair. The facility does not have nugget trays to separate nuggets from the waste rock; they are assessing whether it would be economical to install them.

Fine material passing the screens is passed to a make-up tank where water may be added to make a slurry of 14 to 20 percent solids. According to facility personnel, the wash plant operation used approximately 3,000 gpm of water; most of this is added by spray bars at the grizzly and vibrating screen. From the make-up tank, a Warman slurry pump transfers the slurry to a series of sluices. The wash plant is operating with seven sluice boxes. Two types of sluices are used: five are 34 feet long, sloping 1.25 inches per foot. Four of these are running at any one time. Hungarian riffles are 1.5 inches high and are spaced two inches apart. Below the riffles, the lower 20 percent of the sluices are fitted with expanded metal over astroturf. Two newer sluices use a modified Hungarian riffle one inch high spaced one inch apart. The slope is two inches per foot in the riffle portion and 1.25 inches per foot in the expanded metal portion. A Nomad matting is used under the expanded metal section.

The sluices serve to allow the gravity concentration of gold from other less dense particles. No chemicals are added; the operation is entirely mechanical. The relatively more dense gold accumulates in the lee of the riffles and in the matting, with the remainder of the slurry (water and less dense gangue) flowing over the

riffles to become tailings. Tailings from the sluice boxes empty into a pump box where they are pumped to one of three settling ponds (also called tailings ponds).

The sluices were shut down and cleaned of gold every one or two days. Matting is picked and washed. The material is put in buckets and carried to the gold room. In the gold room, magnetic separation is used to separate heavy minerals such as magnetite from the gold. Following this, a jig, a table, and a Knudsen bowl are used to further separate gold from gangue. In a jig, slurry flows horizontally through a box with a screen top through which water is pulsed, separating more dense from less dense material. A table is an inclined table with small channels. The quantities of waste generated in this operation were not obtained; however quantities are minimal compared to the amount of tailings generated.

As discussed above, tailings were sent to settling ponds. There are three settling ponds in this system; the system is designed to allow settling of tailings and recycling of the water to the wash plant. Two ponds are unlined and the dam on the remaining pond is lined at one end of the pond. The operation discharged a low solids slurry from the wash plant into the primary sluice pond, which discharged to the secondary sluice pond and then to the tertiary sluice pond, where water is reclaimed and pumped back to the wash plant operation. These ponds are actually old mining pits A4 and A5 and are called the E4 and E5 wash plant ponds by the facility. According to facility personnel, each was approximately five acres in size with the deepest being 20 feet and the others ranging in depth from five to 10 feet. The ponds had a total capacity of 340 acre-feet (Cambior 1990). This pond system is intended to totally recycle all wash plant water. In addition to wash plant water, effluent from dewatering the pit was also discharged to these ponds (Cambior 1990).

Cambior had structural integrity problems with the first pond. This pond has failed twice, in 1991 and 1992. At the time of the site visit, the pond had been reconstructed and lined and Cambior was refilling the pond with water to test its integrity. Cambior expects a final permit for this pond when the construction is finished. These pond failures are discussed in more detail in Section 4.

As discussed above, water use in the wash plant was estimated by facility personnel to be approximately 3,000 gpm. Water sources for the operation include recycled water from the sluice ponds, which constitutes about 90 percent of the total flow. The remaining flow is make-up water from Valdez Creek (BLM 1990).

Figure 3-4

US EPA ARCHIVE DOCUMENT

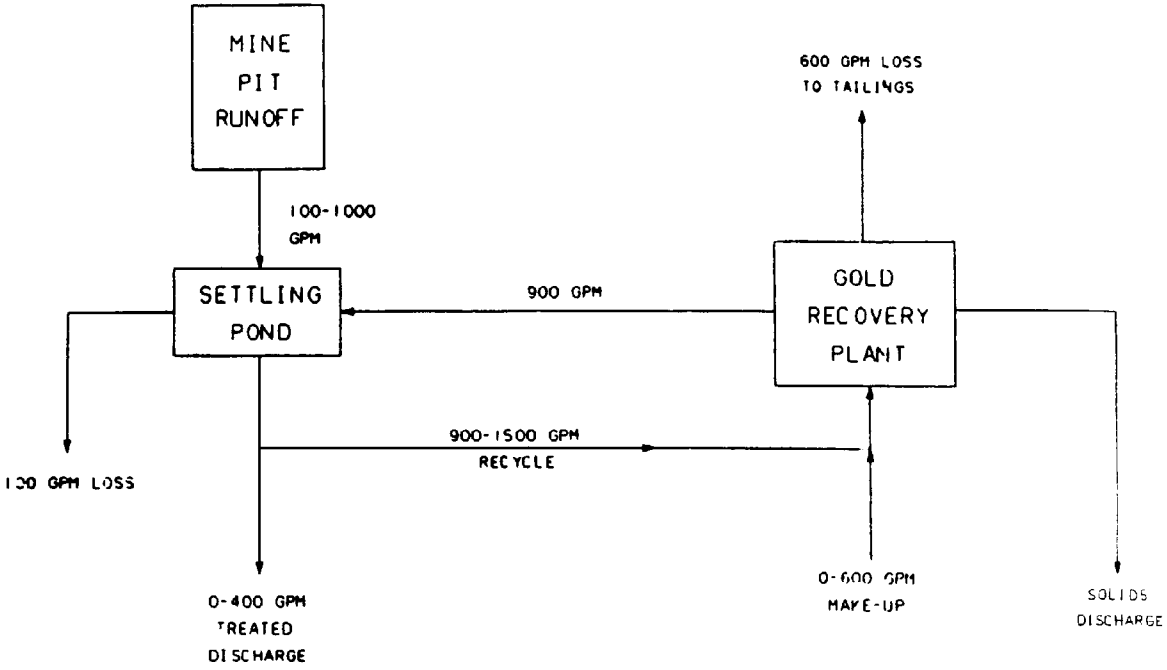

1992-1994 WATER BALANCE  
VALDEZ CREEK MINING COMPANY

Figure 3-4. Water Balance for 1990 Through 1991

(Source: EA 1990)

is a diagram showing the 1990 through 1991 water balance according to the Environmental Assessment. Note that the total volume used at the wash plant estimated in the Environmental Assessment differs from the estimate provided for current usage.

### 3.2.3.1 Ancillary Facilities

If the plant is shut down or if there is excessive runoff, the settling ponds discharge to a system of older settling ponds (called the Willow Creek Ponds). These ponds are old settling ponds that were constructed during previous operations.

Any discharge from the new settling pond system is routed through a series of ditches to the uppermost pond of the old pond system, which consists of six ponds. Discharge to the Creek from the old system is through an outlet from the Willow Creek Number 1 dam, the NPDES discharge point. (Cambior 1990)

A pump station has the capacity to supply 4,400 gpm to the plant. More detailed information on the pump station was not obtained. The facility operates three diesel boilers to provide steam during winter operations. There are steam lines under the ore pile keep the ore pile from freezing.

## 3.3 MATERIALS AND WASTE MANAGEMENT

Wastes and materials managed onsite at the Valdez Creek placer mine include large volumes of waste rock and tailings, as well as used or spilled material not uniquely related to mining. In addition other materials, such as mine water are generated onsite. Because these material ultimately become wastes when intended for disposal, they are also addressed here.

### 3.3.1 Waste Rock

Waste rock was generated during excavation of the pit and consists of overburden removed to access the ore. Waste rock typically consists of poorly sorted glacial material with some lenses of well sorted gravels and cobbles. As discussed previously, according to the Environmental Assessment, the facility extracted approximately 34,000 cubic yards of material each day. During operation, approximately 3,000 cubic yards passed through the wash plant per day. According to facility personnel, the waste to ore ratio is about 11 to 1. Table 3-1 provides the estimated volume of overburden and pay gravels in each of the planned areas. Based on Table 3-1, the stripping ratio for Pit A7 is approximately 13:1 (waste to ore).

Most waste rock is used to backfill older pits, however, there is always an amount remaining to be disposed of elsewhere due to swelling caused by the excavation. The swell factor or ratio for materials at this site was not obtained. The excess waste rock is piled onsite. As discussed later in this section, a solid waste landfill is located on one of the waste rock piles. Chemical analysis of the waste rock was not obtained.

### 3.3.2 Tailings

Tailings generated at the Valdez Creek Mine can be categorized into three types: one type consist of oversize material generated during the initial stages of washing; a second type consists of a low solids slurry generated as discharge from the wash plant; the third type is generated during final concentration of the gold in the gold room. The volume of tailings generated from each different part of the operation varies greatly, with discharge from the wash plant at a rate of 3,000 gpm, while tailings from the final concentration may be measures in terms of buckets per day.

Tailings separated during initial stages of washing include anything larger than 3/4 inches. This material is generated at both the grizzly (material greater than 6 inch) and the vibrating screens (material greater than 3/4 inch) of the wash plant. Tailings may also contain gold nuggets, discarded from the washplant due to size. According to the facility this material was stored in piles and used to maintain roads onsite. Tailings from the final stages of concentration, where gold concentrate is further separated from gangue using magnetic separation, a jig, a table, and a Knudsen bowl, consist of fine gangue minerals. This material was poured back into the system at the top of the sluice.

The highest volume of tailings generated was the low solids slurry discharged from the wash plant to the sluice ponds. The slurry consists of the less dense gangue minerals (all material less than 3/4 inch that was introduced to the wash plant) and water. Because no chemical additives are used in the wash plant, none are expected in the tailings. Constituent analysis of the water was not obtained.

As discussed previously, these tailings were discharged to a settling pond system. After settling, process water is then reused in the wash plant. The settling pond system is made of three settling ponds in a series with water pumped back to the wash plant from the third pond; only the dam between the first and second pond is lined. According to facility personnel, the ponds were constructed in two old mining pits; each is approximately five acres in size with the deepest being 20 feet and the other two ranging in depth from five to 10 feet. The ponds have a total capacity of 340 acre-feet (Cambior 1990). Dam and other construction-related details were not obtained. This pond system is intended to totally recycle all wash plant water. In addition to wash plant water, an unspecified volume of effluent from dewatering the pit is also discharged to these ponds (Cambior 1990). Information was not obtained on the estimated amount of water lost to seepage from this pond system.

Although the settling pond system is generally operated as a zero discharge system, during periods of high runoff or plant shutdown, excess water is routed through ditches to the uppermost of six additional settling ponds (Cambior Mining 1990). The lowest of the ponds discharges wastewater to Valdez Creek through a NPDES discharge point. These ponds, called the Willow Creek Ponds, allow additional settling of suspended solids prior to discharge to the Creek. Originally, the ponds were used as settling ponds during previous operations. According to facility personnel, the Willow Creek Ponds are constructed on native compacted soil. At the time of the site visit, the facility was not using the wash plant so mine water and other process water was being discharged to these ponds rather than being pumped back to the wash plant.

The size and theoretical efficiency of the settling ponds is presented in Table 3-2. The Environmental  
 Table 3-2. Theoretical Efficiency of Settling Ponds  
 (Source: BLM 1990)

Theoretical Efficiency of Settling Ponds  
 at Denali Mine (existing)

| Structure        | Surface Area<br>(acres) | *Water Flow<br>(gpm) | **Overflow<br>(gpm/A) |
|------------------|-------------------------|----------------------|-----------------------|
| Settling Pond #1 | 3.90                    | 5000                 | 1282                  |
|                  |                         | 1000                 | 256                   |
|                  |                         | 4400                 | 1128                  |
| Settling Pond #2 | 3.80                    | 5000                 | 1316                  |
|                  |                         | 1000                 | 263                   |
|                  |                         | 4400                 | 1157                  |
| Settling Pond #3 | 4.20                    | 5000                 | 1191                  |
|                  |                         | 1000                 | 238                   |
|                  |                         | 4400                 | 1047                  |
| Settling Pond #4 | 16.9                    | 5000                 | 295                   |
|                  |                         | 1000                 | 59                    |
|                  |                         | 4400                 | 260                   |
| Settling Pond #5 | 8.50                    | 5000                 | 588                   |
|                  |                         | 1000                 | 118                   |
|                  |                         | 4400                 | 517                   |

\* Process water rate through system. Maximum flow 5000 gpm, minimum probable 1000 gpm, design flow 4400 gpm.

\*\* To obtain adequate sedimentation, the settling pond is recommended to have an overflow rate of not more than 3700 gal/min/acre. (The overflow rate is the flow rate divided by the surface area of the settling pond.) To obtain maximum sedimentation, the overflow rate should not be more than 860 gal/min/acre.

US EPA ARCHIVE DOCUMENT

Assessment and Facility personnel identify five ponds while a letter from Cambior to EPA Region 10 identifies six ponds. According to facility personnel, the additional pond is a small mining pit that water flows through before it reaches the willow creek ponds. Information on the quantity and frequency of settling pond discharge to these settling ponds was not obtained. However, discharge from the lowest pond in the Willow Ponds system through the NPDES discharge point is presented in Table 3-3

Table 3-3. NPDES Discharge Rates  
 (Source: Cambior 1990)  
**INSTANTANEOUS DAILY FLOW MEASUREMENTS<sup>1</sup>**  
**WILLOW CREEK MINE NO. 1 DISCHARGE PIPE**  
**(GPM)**

MONTHS OF:

| DATE | SEPTEMBER         | OCTOBER | NOVEMBER      |
|------|-------------------|---------|---------------|
| 1    |                   | 63      | 848           |
| 2    |                   | N.R.    | 1058          |
| 3    |                   | N.R.    | 351           |
| 4    |                   | N.R.    | 230           |
| 5    |                   | 17      | N.R.          |
| 6    |                   | 5       | N.R.          |
| 7    |                   | 17      | 230           |
| 8    |                   | 17      | 351           |
| 9    | 2268              | 17      | 230           |
| 10   | 2213              | 17      | 351           |
| 11   | 2268              | 17      | N.R.          |
| 12   | 1290              | N.R.    | 230           |
| 13   | 1172              | N.R.    | 134           |
| 14   | 574               | 17      | N.R.          |
| 15   | 179               | N.R.    | N.R.          |
| 16   | 134               | 37      | OUTLET FROZEN |
| 17   | N.R. <sup>2</sup> | N.R.    | OUTLET FROZEN |
| 18   | 17                | 17      | OUTLET FROZEN |
| 19   | 17                | 17      | OUTLET FROZEN |
| 20   | 17                | 5       | OUTLET FROZEN |
| 21   | 17                | 5       | OUTLET FROZEN |
| 22   | 134               | 0       | OUTLET FROZEN |

<sup>1</sup> California Pipe Method.

<sup>2</sup> N.R. = No Reading.



Table 3-3. NPDES Discharge Rates (continued)

| DATE | SEPTEMBER | OCTOBER | NOVEMBER      |
|------|-----------|---------|---------------|
| 23   | 5         | 0       | OUTLET FROZEN |
| 24   | 134       | 0       | OUTLET FROZEN |
| 25   | 63        | 0       | OUTLET FROZEN |
| 26   | 134       | N.R.    | OUTLET FROZEN |
| 27   | 63        | N.R.    | OUTLET FROZEN |
| 28   | 37        | N.R.    | OUTLET FROZEN |
| 29   | 63        | 134     | OUTLET FROZEN |
| 30   | 63        | 1058    | OUTLET FROZEN |
| 30   | ----      | 494     | OUTLET FROZEN |

. This discharge is monitored for arsenic, settleable solids and turbidity. According to a single sample taken (date of sampling not obtained), both turbidity and arsenic were slightly above background levels but well below NPDES limits. (Cambior 1990) See Section 3.4 for more information on NPDES compliance.

### 3.3.3 Other Materials

In addition to mining wastes and materials, the facility generated wastes and materials from routine operations that are not uniquely related to mining. These activities include equipment maintenance, spill clean-up, etc. The facility operated a permitted landfill for disposal of solid waste generated onsite. The main purpose of this landfill is to contain incinerator ash and residue and oil spill material from routine activities at the site. The cell for oil spill material, which is to contain approximately 3500 cubic yards of waste, was located on an old waste rock pile. The cell had a single liner and a leak detection system installed below the liner. During the site visit, facility personnel reported that the containment cell is being re-sealed as the original seams were not sufficiently sealed. As of the date of EPA's site visit, no material had been disposed of in the lined cell. Disposal was expected to begin once the seams have been effectively sealed. According to the Solid Waste Permit Application, the landfill is located away from surface water and is over 200 feet above the regional water table. (Valdez Creek Mining Company 1988) Additional construction details and current usage were not obtained. The oil spill material was generated by previous operators. According to facility personnel, prior to 1988, previous operators disposed of used oil by dumping it into a pit for burning and tires were added to keep the flame burning.

The facility had two methods of trash disposal, a putrescible waste incinerator, and an "air curtain burn box." The incinerator was used for disposal of domestic waste. (Valdez Creek Mining Company 1988) According

to facility personnel, wood and other large debris are burned in the burn box, a large steel container. Ash from these operations was disposed of in the landfill. (Valdez Creek Mining Company 1988)

Waste oil was blended with diesel fuel and burned in waste oil furnaces. Wash water was directed to a sump where a skimmer removes grease and oil, which are also burned in the waste oil furnaces. Spent solvents from parts washing were also mixed with the waste oil and burned. The facility has a State permit for the waste oil furnaces. The furnaces were made by Clean Energy Inc. and have a 500,000 BTU capacity. Approximately 8,800 gallons of used oil was generated and burned in June of 1992.

Antifreeze was recycled on site. The facility designed and constructed an antifreeze distillation unit in order to recycle antifreeze. Because of the quantities of antifreeze used, and the difficulty and expense of transporting antifreeze to such a remote site, the facility found recycling of the antifreeze to be cost effective. The quantity of antifreeze recycled was not obtained.

Most of the facility's tires were hauled to a dump in Glenellen. Some tires are also used for lightpole anchors. The facility stored scrap iron and steel, such as worn undercarriages, bucket teeth, chain, plate steel, and pipe, in a forty foot hopper and sent it to a recycler in Anchorage. Approximately 120 tons per quarter is been recycled in this manner. Aluminum is also sent to a recycler at an approximate rate of 20 cubic yards a quarter.

The facility operated two septic systems, one for the main site and one for campers. An additional septic system is located at the Little Idaho camping area.

There are four 15,000 gallon diesel tanks and two 10,000 gallon diesel tanks on site, and this storage area is lined and bermed. Other items stored onsite include antifreeze, solvents, gear lubricant, ANFO, and propane. According to facility personnel, all tanks are above ground. Table 3-4

**Table 3-4. Storage Tank Summary**

| Tank Description                | Location                                 | Contents   | Capacity (Gal.)   | Containment (Gal.)              | Factor of Safety |
|---------------------------------|--|--|---|---------------------------------|------------------|
| Gasoline Storage                | Main Camp                                | Unleaded Gasoline  | 6,000   | 35,000                          | 5.8              |
| Diesel Storage                  | Main Camp                                | No. 1 Diesel   | 15,000  | 21,000                          | 1.4              |
| Diesel Storage                  | Main Generator Installation              | No. 1 Diesel   | 500   | 600                             | 1.2              |
| Lubricant and Waste Oil Storage | Cold Storage Building                    | Motor Oil<br>Hydraulic Fluid<br>Ethylene Glycol<br>Transmission Fluid<br>Petroleum Naphtha<br>Grease<br>Waste Oil<br>Blending Tank<br>Blending Oil | 3,000<br>3,000<br>1,000<br>3,000<br>3,000<br>550 <sup>1</sup><br>275 <sub>1</sub><br>400lbs<br>16,000 <sup>2</sup><br>6,000<br>10,000 | 14,500 <sup>3</sup>             | 1.3              |
| Miscellaneous Drum Storage      | Maintenance Shops                        | Transmission Fluid<br>Petroleum Naphtha  | 220 <sup>1</sup><br>110 <sup>1</sup>  | Operating Controls <sup>4</sup> | N/A              |
| Diesel Storage                  | Wash Plant Generator                     | No. 1 Diesel   | 500   | 6,000                           | 12.0             |
| Diesel Storage                  | Sample Laboratory Generator              | No. 1 Diesel   | 250   | 300                             | 1.2              |
| Diesel Storage                  | Operations Staging Area                  | No. 1 Diesel<br>Transmission Fluid<br>Petroleum Naphtha and Lubricants   | 15,000<br>15,000<br>15,000<br>27,50 <sup>1</sup>  | 350,000                         | 23.3             |
| Diesel Storage                  | ANFO Mix Truck                           | No. 1 Diesel   | 230   | Operating Controls <sup>4</sup> | N/A              |
| Aviation Fuel Storage           | Airstrip                                 | Aviation Fuel  | 275   |                                 |                  |
| Diesel Storage                  | Pump Installation                        | No. 1 Diesel   | 120 <sup>5</sup>  |                                 |                  |
| Diesel/Lubricant Storage        | Mobile Fueling and Lubrication Equipment | No. 1 Diesel Fuel/<br>Lubricants   | 3,000<br>1,300  | Operating Controls <sup>4</sup> | N/A              |

**Notes:** <sup>1</sup> Drum Storage (Capped 55 gallon drums on pallets).

<sup>2</sup> Waste Oil Storage Tank active level is less than or equal to 2/3 capacity (10,700) gallons).

<sup>3</sup> Containment capacity for Lubricant and Waste Oil Storage includes 5,000 gallons existing curb capacity, 7,000 gallon existing sump capacity, and 2,500 gallon proposed additional curb capacity.

<sup>4</sup> Operating controls include temporary berms, regular inspections and specific operating practices as appropriate.

<sup>5</sup> Fuel storage at any given pump installation does not exceed 120 gallons.

Source: Spill Prevention Control and Countermeasures Plan and Oil Discharge Prevention and Contingency Plan, January, 1992.

provides a list of tanks onsite.

### 3.4 REGULATORY REQUIREMENTS AND COMPLIANCE

The Valdez Creek Mine was subject to both State and Federal regulatory requirements and their attendant permits. Because the operation is located on Federal land under the jurisdiction of the Bureau of Land Management, the facility has prepared a Plan of Operations to satisfy BLM requirements. The facility has an NPDES permit issued by the EPA Region X, as well as several dredge and fill permits from the Army Corp of Engineers. State permits include dam safety and solid waste disposal. The State of Alaska has an optional annual placer mining permit; according to facility personnel, Cambior has not applied because the permit is optional. The State has no reclamation requirements; however, BLM has requirements for reclamation with a schedule of acreage in the Plan of Operations.

#### 3.4.1 Federal Permits

##### 3.4.1.1 Bureau of Land Management

Because the facility is located on Federal lands, BLM requires a Plan of Operations. BLM approved the Valdez Creek Plan of Operations on June 19, 1990; the Plan is effective for five years.

Reclamation requirements include a schedule for reclamation of acreage, as specified in the Plan of Operations. The Plan addresses smoothing of the pit walls, creek beds, old ponds and old roads. The facility is working on areas U and V this year, and is using aerial seeding as a method as hydroseeding has not worked well in the past (see Figure 3-2). The facility recontours slopes to 3:1 or shallower. Grass, clover and willow have been seeded. According to the facility, the total acreage reclaimed in 1992 is approximately 180 acres; the facility plans to reclaim 135 new acres and 45 old (previously reclaimed) acres each year. Specific details describing any problems that may arise with reclamation, other than access to areas with the hydroseeding equipment, were not obtained. According to facility personnel, immediate plans for reclamation include the A6 Pit this year (see Figure 3-2).

##### 3.4.1.2 Army Corp of Engineers

The facility has an Army Corp of Engineers CWA Section 404 permit for construction of the diversion dam. It was issued on August 11, 1990 and expires in 1995. The Corps. has also issued smaller permits for culverts and other smaller disturbances. These permits were not obtained.

##### 3.4.1.3 Environmental Protection Agency

###### NPDES Permit

The Environmental Protection Agency's Region X Office has issued an NPDES permit to the facility. The permit, number AK002497-0, was issued on July 10, 1989 and is effective for five years. Effluent limitations set in the permit include: Turbidity 398 NTU's above background; settleable solids 0.2 ml/l; and

total arsenic 0.05 mg/l. As discussed previously, discharge is from the Willow Ponds system through a pipe in Willow Creek dam. Table 3-3 shows discharge rates for a season. Discharges may be exempt from the numeric limits if the facility qualifies for the "Storm exemption" in part I.D. of the permit. They apparently availed themselves of this exemption three times from December 1990 to November 1991, when storm events exceeded the 5-year 6-hour storm (the quantity required to be stored to qualify for the storm exemption). The facility is required to monitor their discharge once per season for arsenic and turbidity and once per day (during discharge) for settleable solids.

According to a single sample taken (date of sampling not obtained), both turbidity and arsenic were slightly above background levels but well below permit limits. In addition, there were three exceedances of the settleable solids, two in May and one in August 1991. According to the facility, these exceedances reflect natural events. (Cambior 1990) Additional compliance data was not obtained.

#### Hazardous Waste

Cambior generates hazardous waste at the Valdez Creek mine in the laboratory and is considered a conditionally exempt small quantity generator. The waste, mercuric nitrate, is generated in a solution from washing of the amalgam bead used in analysis of drill cores in the lab. The SIC code is 1041. The facility has a generator ID Number, AKD982656761.

### 3.4.2 State Permits

#### 3.4.2.1 Dam Safety

The facility has State Dam Safety Permits, which are divided into 3 sections: the settling ponds (also called Willow Creek ponds); the diversion dam (also called the Aspen 4 Dam); and the sluice ponds. There are 5 Willow Creek Ponds, each is approximately 10 acres each. They were constructed of native compacted soils with no liner or grout and have decants and spillways.

The diversion dam, as described previously, is approximately 200 feet wide and over 25 feet tall with a crest width of approximately 50 feet. The area impounded during breakup is two to three times the normal impoundment size of 25 acres and reaches a maximum of approximately 100 acres. Typically, the water is only a few feet deep; but at breakup it may reach 10 feet in depth. The diversion ditch leads approximately 5,000 feet downhill, from the diversion dam to the point where it discharges to the creek. The diversion ditch is lined with a synthetic liner and rip-rap to prevent erosion and downcutting.

The sluice ponds are actually old mining pits A4 and A5 and are called the E4 and E5 wash plant ponds. There are actually three ponds in this system, each approximately five acres in size with the deepest being 20 feet and the others ranging from five to 10 feet deep. The dam between the first and second ponds is lined with a synthetic liner due to seepage problems. The ponds are used to recycle water from the wash plant. Tailings are discharged from the wash plant into the primary settling pond, which discharges to the secondary

settling pond and then to the tertiary settling pond, where water is reclaimed and pumped back to the wash plant. Cambior has had several problems with pond 2, which has failed twice. At the time of the site visit, the dam had been reconstructed and lined and Cambior was refilling the pond with water to test its integrity. Cambior expects a final permit for this pond when the construction is finished.

#### 3.4.2.2 Diversion Channel

On November 2, 1992, the Alaska Department of Environmental Conservation issued a Certificate of Reasonable Assurance, in accordance with Section 401 of the Clean Water Act of 1977, for the placement of fill material into wetland areas. Approximately 30,229,400 cubic yards of fill will be discharged into 317 acres of waters of the U.S. (wetlands) for the construction of the 4800 foot long Stage II lined diversion channel. The existing one mile long Stage I diversion channel has been designated, by this Department, as a mixing zone for the flushing of the new lined channel. As a condition of the Department's issuance of the Certificate of Reasonable Assurance, Cambior is required to have a third party conduct water quality monitoring, for turbidity and settleable solids, during the actual flushing of the new channel.

#### 3.4.2.3 Alaska Fish and Game

Alaska Fish and Game has issued a permit to move fish from below the facility to above the diversion dam during spawning. Cambior has retained the services of Potterville Specialties Service and Northern Alaska Fisheries Services to move the fish each year. The activities take place several days each week over a period of about a month and a half in the spring. According to Cambior personnel, the facility appears to be dealing with two distinct fish populations.

#### 3.4.2.4 Solid Waste Permit

The facility has permits for two landfills, a putrescible waste incinerator, and an "air curtain burn box." (Valdez Creek Company 1990). According to facility personnel, the facility also has a permit to operate used oil furnaces; this permit was not obtained during EPA's site visit. According to facility personnel, oil filters are no longer burned in the burn box as specified in the permit by direction of a DEC inspector.

According to the Alaska Department of Environmental Conservation (DEC), the facility has one Solid Waste Disposal Permit, which expires in November 1993. The permit allows for the seasonal disposal of oily soil, incinerated camp waste, and non-combustible residue into lined containment cells at the mine site. There is no limit as to the number of individual cells that can be developed under this permit.

Used oil filters were previously being burned in the burn box. State regulations concerning open burning, prohibit the burning of oily wastes or other materials that give off black smoke, without written permission from the Department. Due to a potential air quality violation, Cambior personnel were instructed by a Department inspector to dispose of used oil filters in the lined containment cells.

Currently, new State Solid Waste Management Regulations are being developed in preparation of the new EPA Solid Waste Regulations that will become effective no later than October 1993. At this time, it is uncertain how these new regulations will affect the renewal of Cambior's solid waste disposal permit.

### 3.4.3 Inspections and Compliance Incidents

#### 3.4.3.1 Inspections

##### Department of Environmental Conservation

According to Cambior personnel, DEC inspects the facility once per year to review waste management, including the incinerator and burn box, the septic system, trash and other solid waste disposal, as well as water quality. According to the Alaska DEC, there were three inspections during 1991 and one inspection in 1992 (as of November 1992). The most recent unannounced inspection occurred approximately three weeks prior to EPA's site visit. According to Cambior, the inspector verbally noted erosion on the side of the diversion channel caused by breakup but did not send a report to the facility in writing. According to Cambior, the State typically does not send inspection reports to the facility unless there is a serious problem.

The Little Idaho campground is located on land within the claim block that Cambior Ak leases from BLM. Little Idaho is not a public campground and is restricted by Cambior to employee use only. The drinking water and wastewater disposal systems at the camp serve a bath/toilet house and RV dump station available to campers. There are no individual water or sewer hookups to the camping spaces. The campground is used seasonally during summer months only.

Construction approval, for both water and sewer systems, was issued by this Department in the Summer of 1992. The sewer system, after construction, was put into use by Cambior without a final operating approval from this Department. A 30-day interim operational approval was issued for the water system only, which expired September 6, 1992. Final operational approvals for these systems have not yet been issued, and are pending submittal and approval of engineers as-builts of the installed sewer system and satisfactory water sample analysis results on the water system.

##### Bureau of Land Management

Representatives from the BLM visited the site one week prior to EPA's site visit. BLM voiced concern about uncontrolled camping. Little Idaho is a permitted camping area for employees provided by Cambior. The BLM expressed concern over camping outside of designated areas by others visiting the area. The number of visitors increases especially during hunting season. According to Cambior personnel, Little Idaho is outside of the active mining area on public land.

##### Mine Safety and Health Administration

The Mine Safety and Health Administration inspects the facility twice a year. The most recent inspection prior to EPA's site visit was in March of 1992. There were a number of violations cited with the most serious addressing a ladder in a culvert with no safety loops and "dumpover," where a truck backs to the very edge of a pit and dumps its load. The preferred method is to dump and then use a dozer to push material to the edge of the pit. Noise and dust at the washer plant, and at drills and dozers were also reviewed with no citations issued. The fines for this inspection totalled approximately \$600.

#### 3.4.3.2 Compliance Incidents

##### Waste Oil

According to facility personnel, an oil spill was identified in the area surrounding the generator shack. The facility attributed the release to drips over several years of operation. Approximately 75 cubic yards of contaminated soil were excavated and will be disposed on site in a containment cell permitted by the State. According to facility personnel, prior to 1988, previous operators disposed of used oil by dumping it into a pit for burning and tires were added to keep the flame burning. According to Alaska DEC, some, but not all, of the contaminated soil has been excavated and disposed of in a containment cell covered by the Solid Waste Disposal Permit. In addition, in 1991, extensive oil spill contamination was discovered in an outside area known as the "dead line," which is used for heavy equipment storage and repairs. The Department required that a third party consultant conduct a site assessment and corrective action plan for these two contaminated areas. To date, these two contamination issues are still unresolved.

During this Department's June 1992 inspection, it was noted that Cambior had improved maintenance practices and preventative procedures to help prevent soil contamination. Small quantity releases occur fairly often at the mine site from such things as equipment hydraulic line breakage, and outside equipment maintenance, including oil and fluid changes, and leakage of fluids from equipment awaiting repairs.

A contaminated waste management plan, submitted by Cambior on September 9, 1992 was found to be unacceptable to the Department. The plan included a spring cleanup of contamination occurring during the winter months, periodic cleanup during the summer months, and "reportable" spills to be cleaned up immediately. The plan did not include how a determination would be made to insure adequate cleanup or how appropriate minimum target cleanup levels would be met. State regulations require all spills to be cleaned up immediately. Cambior is revising their waste management plan to meet state regulations and the concerns of the Department.

##### Fuel Spill

According to facility personnel, approximately three to four years ago a truck dumped fuel on the ground. No additional details concerning this spill were obtained.

##### Dam Failure



October 27, 1991, the first pond of the three sluice ponds used by the facility failed and released approximately 50 million gallons of tailings water into Valdez Creek. As required by the Alaska DEC, the facility conducted TCLP testing on the sediments and found no toxic contamination. The Department further required the deposited sediments to be pulled back from the creek to prevent spring breakup high water flows from eroding the sediments and creating a water quality violation of turbidity and settleable solids. Stabilization of the slope, and silt fences to protect the quality of the creek, were also required by the Department. During the actual releases, it is highly suspected that water quality standards were drastically exceeded downstream within Valdez Creek. On May 25, 1992, the same pond failed during testing and approximately 15 million gallons of water were released into the creek. At the time of the site visit, the dam had been reconstructed, with a liner and piezometers, and facility personnel were preparing to fill and retest it. No other details on these failures were obtained. It is unclear whether the releases of water caused exceedance of arsenic and other water quality standards downstream on Valdez Creek. According to the DEC, water quality monitoring was not conducted by Cambior during the two dam failure events.

### **3.5 REFERENCES**

- Bureau of Land Management. Denali Mine, 1990 - 1994 Environmental Assessment. Prepared for BLM by Environmental Services, Ltd., May 1990.
- Bureau of Land Management. Letter from Gene Keith, District Manager, to Paul Martin, VCMC, approving the updated 5-year Plan of Operations and Environmental Assessment. June 29, 1990.
- Cambior Alaska. Letter from Douglas Nicholson, Chief Engineer, Cambior Alaska, Inc. to Director, Waster Division, Region X U.S. EPA, concerning Discharge Monitoring Reports for NPDES permit AK-002497-0, for the period 12/10/90 through 11/30/91. November 29, 1991
- Cambior Alaska, Inc. Spill Prevention, Control and Countermeasures Plan (SPCC Plan) and Oil Discharge Prevention and Contingency Plan, prepared for Cambior by ACZ Inc. Steamboat Springs CO. (Only portions obtained). January 1992.
- Cambior Alaska, Inc. 1991 Hazardous Waste Report, EPA Form IC, Identification and Certification, EPA ID No. AKD-982-656-761, February 28, 1992.
- Department of the Army, Army Corp of Engineers. Permit Number 4-890170 permit modification notification, Valdez Creek 1. August 21, 1990.
- State of Alaska. State vs. Valdez Creek Mining Company, Inc. Case No. 3PA-S88-315 Cr. Dated June 1988. WHEREAS there was some pollution . . . . Undated.
- State of Alaska. Dam Safety Certificate of Approvals for Willow Creek 5 dam and A4 pond system, March 25, 1992.
- State of Alaska, Department of Natural Resources. Letter from Kyle Cherry to Assistant General Manager, VCMC, approving continued operation of the Aspen 4 dam. January 23, 1992.
- State of Alaska, Department of Environmental Conservation. Letter from Henry Friedman to Environmental Services, Ltd. concerning the draft solid waste permit for Valdez Creek Mine. December 1, 1988.

State of Alaska, Department of Environmental Conservation. Letter from Bill Lamoreaux to Richard Hughes, VCMC, issuing permit # 8822-BA004. December 21, 1988.

Valdez Creek Mining Company. Solid Waste Management Permit Application for the Denali Mine, prepared for VCMC by Environmental Services, Ltd. (Only portions obtained). July 1988.

Valdez Creek Mining Company, 1989 - 1993 Plan of Operations, Denali Mine, prepared for VCMC by Environmental Services, Ltd. (Only portions obtained). August 30, 1989

U.S. Environmental Protection Agency. NPDES Permit AK-002497-0 for Valdez Creek Mining Company. Effective 8/09/89 through 8/08/94.

US EPA ARCHIVE DOCUMENT

**APPENDIX 3-A**

**COMMENTS SUBMITTED BY CAMBIOR ALASKA INC.,  
ON DRAFT SITE VISIT REPORT**

The letter reproduced in this appendix accompanied a copy of the draft site visit report on which Cambior Alaska Inc., had made comments and corrections. A copy of the marked-up draft is not reproduced here for brevity's sake. In general, Cambior's comments were clarifying in nature, providing information that the draft report indicated had not been obtained during the site visit or correcting minor factual errors in the draft. EPA's response to Cambior's comments are provided in Appendix B.

**APPENDIX 3-B**

**EPA RESPONSE TO COMMENTS SUBMITTED BY  
CAMBIOR ALASKA INCORPORATED  
ON DRAFT SITE VISIT REPORT**

EPA Response to Comments Submitted by  
Cambior Alaska Incorporated  
on Draft Site Visit Report

EPA has revised the report to incorporate all of the comments and suggestions made by Cambior Alaska Incorporated. In some cases, EPA made minor changes to wording suggested by Cambior in order to attribute the changes to Cambior or to enhance clarity.

**US EPA ARCHIVE DOCUMENT**

**APPENDIX 3-C**

**COMMENTS SUBMITTED BY THE STATE OF ALASKA  
ON DRAFT SITE VISIT REPORT**

**APPENDIX 3-D**

**EPA RESPONSE TO COMMENTS SUBMITTED BY  
THE STATE OF ALASKA  
ON DRAFT SITE VISIT REPORT**

EPA Response to Comments Submitted by  
The State of Alaska  
On Draft Site Visit Report

EPA has revised the report to incorporate all of the comments and suggestions made by the State of Alaska. In some cases, EPA made minor changes to wording suggested by the State.

**US EPA ARCHIVE DOCUMENT**