

US EPA ARCHIVE DOCUMENT

Report of  
Dam Safety Assessment of Coal Combustion  
Surface Impoundments

Kentucky Utilities,  
a wholly owned subsidiary of  
LG&E and KU Energy LLC

Green River Station, Central City, KY

AMEC Project No. 3-2106-0177-0002

Prepared By:

AMEC Earth & Environmental, Inc.  
690 Commonwealth Center  
11003 Bluegrass Parkway  
Louisville, KY 40299

Prepared For:

U.S. Environmental Protection  
Agency  
Office of Solid Waste and  
Emergency Response  
Office of Conservation and  
Recovery  
1200 Pennsylvania Ave., NW  
MC: 5304P  
Washington, DC 20460

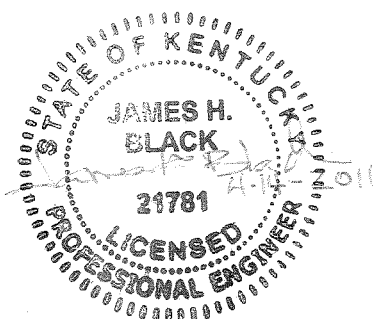

April 2011



I certify that the management units referenced herein:

Kentucky Utilities, a wholly owned subsidiary of LG&E and KU Energy LLC, Green River Power Station: Ash Treatment Basin #1 (Main Pond), Ash Treatment Basin #2, Finishing Pond #3, Scrubber Pond and the Former Ash Pond (coal runoff pond) were assessed on August 16, 2010.

Signature James Black 4-14-2011  
James Black, PE  
Project Engineer

List of AMEC Participants who have participated in the assessment of the management units and in preparation of the report:

- Chris Eger  
CADD Technician
- Dan Conn  
GIS Specialist
- Mary Sawitzki, PE  
Civil/Environmental Engineer
- Shea Carr, PE  
Project Engineer

**TABLE OF CONTENTS**

<b>SECTION</b>		<b>PAGE NO.</b>
<b>1.0</b>	<b>INTRODUCTION AND PROJECT DESCRIPTION.....</b>	<b>1</b>
1.1	Introduction.....	1
1.2	Project Background.....	1
1.2.1	State Issued Permits .....	3
1.3	Site Description and Location .....	3
1.4	Process Ponds.....	4
1.4.1	Ash Handling and Flow Summary.....	4
1.4.2	Ash Treatment Basin #1 .....	5
1.4.3	Ash Treatment Basin #2 .....	7
1.4.4	Finishing Pond #3.....	7
1.4.5	Scrubber Pond .....	8
1.4.6	Coal Pile Runoff Pond .....	8
1.5	Previously Identified Safety Issues.....	9
1.6	Site Geology .....	9
1.7	Inventory of Provided Materials.....	10
<b>2.0</b>	<b>FIELD ASSESSMENT .....</b>	<b>11</b>
2.1	Visual Observations .....	11
2.2	Ash Treatment Basin #1 (Main Ash Pond) - Visual Observations.....	11
2.2.1	Ash Treatment Basin #1 - Embankments and Crest .....	11
2.2.2	Ash Treatment Basin #1 - Outlet Control Structure .....	12
2.3	Ash Treatment Basin #2 - Visual Observations .....	12
2.3.1	Ash Treatment Basin #2 - Embankments and Crest .....	12
2.3.2	Ash Treatment Basin #2 - Outlet Control Structure .....	12
2.4	Finishing Pond #3 - Visual Observations.....	12
2.4.1	Finishing Pond #3 - Embankments and Crest.....	13
2.4.2	Finishing Pond #3 - Outlet Control Structure.....	13
2.5	Scrubber Pond - Visual Observations .....	13
2.5.1	Scrubber Pond - Embankments and Crest.....	13
2.5.2	Scrubber Pond - Outlet Control Structure .....	13
2.6	Coal Pile Runoff Pond - Visual Observations .....	14
2.6.1	Coal Pile Runoff Pond - Embankments and Crest .....	14
2.6.2	Coal Pile Runoff Pond - Outlet Control Structure .....	14
2.7	Monitoring Instrumentation.....	14
<b>3.0</b>	<b>DATA EVALUATION .....</b>	<b>15</b>
3.1	Design Assumptions .....	15
3.2	Hydrologic and Hydraulic Design .....	15
3.2.1	2010 Hydrologic and Hydraulic Study .....	19
3.2.2	2011 Addendum to the 2010 Hydrologic and Hydraulic Study .....	23
3.3	Structural Adequacy and Stability .....	27
3.3.1	Ash Treatment Basin #1 - July 2010 Structural Adequacy and Stability ..	28
3.3.2	Ash Treatment Basin #2 and Scrubber Pond - September 2010 Structural Adequacy and Stability .....	31
3.3.3	Finishing Pond #3 - Structural Adequacy & Stability .....	33
3.3.4	Coal Pile Runoff/Ash Treatment Basin #2 and Scrubber Pond - December 2010 and January 2011 Structural Adequacy & Stability .....	33
3.4	Foundation Conditions .....	38

3.5	Operations and Maintenance .....	39
3.5.1	Instrumentation.....	39
3.5.2	Inspections .....	41
<b>4.0</b>	<b>COMMENTS AND RECOMMENDATIONS .....</b>	<b>50</b>
4.1	Acknowledgement of Management Unit Conditions .....	50
4.2	Ash Treatment Basin #1 or Main Pond.....	52
4.2.1	Hydrologic and Hydraulic Recommendations .....	52
4.2.2	Geotechnical and Stability Recommendations.....	53
4.2.3	Monitoring and Instrumentation Recommendations .....	54
4.2.4	Inspection Recommendations.....	55
4.3	Ash Treatment Basin #2.....	55
4.3.1	Hydrologic and Hydraulic Recommendations .....	55
4.3.2	Geotechnical and Stability Recommendations.....	57
4.3.3	Monitoring and Instrumentation Recommendations .....	58
4.3.4	Inspection Recommendations.....	59
4.4	Scrubber Pond.....	59
4.4.1	Hydrologic and Hydraulic Recommendations .....	59
4.4.2	Geotechnical and Stability Recommendations.....	60
4.4.3	Monitoring and Instrumentation Recommendations .....	61
4.4.4	Inspection Recommendations.....	62
4.5	Former Ash Pond or Coal Runoff Pond.....	62
4.5.1	Hydrologic and Hydraulic Recommendations .....	62
4.5.2	Geotechnical and Stability Recommendations.....	63
4.5.3	Monitoring and Instrumentation Recommendations .....	64
4.5.4	Inspection Recommendations.....	65
<b>5.0</b>	<b>CLOSING.....</b>	<b>66</b>

**TABLES**

Table 1.	Site Visit Attendees .....	1
Table 2.	MSHA* Minimum Long Term Hydrologic Design Criteria .....	17
Table 3.	2010 Ash Treatment Basin #1 Elevation Conditions .....	20
Table 4.	2010 Ash Treatment Basin #2 Elevation Conditions .....	20
Table 5.	2010 Scrubber Pond Elevation Conditions .....	22
Table 6.	2010 Coal Pile Runoff Pond Elevation Conditions .....	23
Table 7.	2011 Ash Treatment Basin #1 Elevation Existing Conditions.....	24
Table 8.	2011 Ash Treatment Basin #2 Existing Elevation Conditions.....	24
Table 9.	2011 Alternatives 1 and 2 Ash Treatment Basin #2 Elevation Conditions.....	25
Table 10.	2011 Scrubber Pond Elevation Existing Conditions .....	26
Table 11.	2011 Coal Pile Runoff Pond Elevation Existing Conditions.....	27
Table 12.	Minimum Recommended Dam Safety Factors .....	28
Table 13.	July 2010 Stability Analysis Soil Parameters - Ash Treatment Basin #1 .....	29
Table 14.	July 2010 Factors of Safety for Ash Treatment Basin #1 Slope Failure Area .....	30
Table 15.	July 2010 Factors of Safety for Ash Treatment Basin #1 at Critical Section.....	31
Table 16.	September 2010 MACTEC Soil Parameters for Ash Treatment Basin #2 and Scrubber Pond.....	32
Table 17.	September 2010 Slope Stability Analyses Results for Ash Treatment Basin #2 and Scrubber Pond .....	33
Table 18.	MACTEC Stability Analysis Soil Parameters - FINAL REPORT.....	36

Table 19. Slope Stability Analyses Results for Ash Treatment Basin #2 and Scrubber Pond - MACTEC REPORT -ADDENDUM A .....37

Table 20. Piezometer Information .....40

Table 21. Summary of Ash Treatment Basin #2 and Scrubber Pond Piezometer Readings .....40

Table 22. ATC Assessment - Pond Rating Summary .....43

Table 23. Ash Treatment Basin #1 Action Item Summary .....44

Table 24. Ash Treatment Basin #2 Action Item Summary .....45

Table 25. Finishing Pond #3 Action Item Summary .....46

Table 26. Scrubber Pond Action Item Summary.....47

Table 27. Coal Runoff Pond Action Item Summary .....48

**FIGURES**

Site Location & Vicinity Map ..... Figure 1

Site Plan ..... Figure 2

Critical Infrastructure Map ..... Figure 3

Site Topographic Map ..... Figure 4

Ash Treatment Basin #1 Typical Cross-Sections ..... Figure 5

Ash Treatment Basin #2 Typical Cross-Sections ..... Figure 6

Scrubber Cross-Section ..... Figure 7

Coal Pile Runoff Typical Cross-Section ..... Figure 8

Ash Treatment Basin #1 Borings, Piezometers & Cross Sections Locations ..... Figure 9

Ash Treatment Basin #1 Slope Failure Cross Section ..... Figure 10

Ash Treatment Basin #1 Critical Slope Cross Section ..... Figure 11

Ash Treatment Basin #2 Borings, Piezometers & Cross Sections Locations ..... Figure 12

**APPENDICES**

EPA Coal Combustion Dam Inspection Checklists and Coal Combustion Waste Impoundment Inspection Forms - August 2010 .....Appendix A

Site Photo Log Maps and Site Photos .....Appendix B

Inventory of Provided Materials ..... Appendix C

## 1.0 INTRODUCTION AND PROJECT DESCRIPTION

### 1.1 Introduction

AMEC was contracted by the United States Environmental Protection Agency (EPA), via contract BPA EP09W001702, to perform site assessments of selected coal combustion byproducts surface impoundments. AMEC was directed by EPA, through the provided scope of work and verbal communications, to utilize the following resources and guidelines to conduct a site assessment and produce a written assessment report for the coal combustion waste facilities and impoundments.

- Coal Combustion Waste (CCW) Impoundment Inspection forms (hazard rating, found in Report Appendix A)
- Coal Combustion Dam Inspection Checklist (found in Report Appendix A)
- Impoundment Design Guidelines of the Mining Safety and Health Administration (MSHA) Coal Mine Impoundment Inspection and Plan Review Handbook (hydrologic, hydraulic, and stability conditions)
- National Dam Safety Review Board Condition Assessment Definitions (condition rating)

As part of this contract with EPA, AMEC was assigned to perform a site assessment of Kentucky Utilities (a wholly owned subsidiary of LG&E and KU LLC, formerly E.ON U.S.) Green River Power Station, which is located, approximately 6 miles north of Central City, Kentucky as shown on Figure 1, the Project Location Map.

A site visit to Green River Power Station was made by AMEC on August 16, 2010. The purpose of the visit was to perform visual observations, to inventory coal combustion waste (CCW) surface impoundments, assess the containment dikes, and to collect relevant historical impoundment documentation.

AMEC engineers, James Black, PE and Shea Carr, PE were accompanied during the site visit by the following individuals:

**Table 1. Site Visit Attendees**

Company or Organization	Name and Title
LG&E and KU Energy Environmental Affairs	Michael Winkler, Manager- Environmental Programs
Kentucky Utilities	Travis Harper, Chemist III
Kentucky Utilities	Tom Troost, General Manager, Green River Power Station
LG&E and KU Energy Generation Engineering	David J. Millay, P.E., Civil Engineer

### 1.2 Project Background

CCW results from the power production processes at coal fired power plants like Kentucky Utilities (KU) Green River Power Station. Impoundments (dams) are designed and constructed

to provide storage and disposal for the CCW that are produced. KU refers to the five CCW impoundments at the Green River Power Station as “Ash Treatment Basin #1 or Main Pond”, “Ash Treatment Basin #2”, “Finishing Pond #3”, “Scrubber Pond”, and the “Former Ash Pond or Coal Runoff Pond”.

The National Inventory of Dams (NID), administered by the U.S. Army Corps of Engineers (USACE), provides a list of many dams within the United States, as well as hazard potentials related to the listed dams. According to documentation provided by Kentucky Utilities, Ash Treatment Basin #2, Finishing Pond #3, and the Former Ash Pond or Coal Runoff Pond do not appear on the NID. Ash Treatment Basin #1 (or Main Pond) and Scrubber Pond are listed on the NID, with each assigned a low hazard rating.

Kentucky Revised Statute (KRS) 151.100 defines the word dam to mean any artificial barrier, including appurtenant works, which does or can impound or divert water and which either: (a) is or will be twenty-five (25) feet or more in height from the natural bed of the stream or watercourse at the downstream toe of the barrier; or (b) has or will have an impounding capacity at maximum water storage elevation of 50 acre-feet or more. The Kentucky Department for Natural Resources and Environmental Protection’s (KDEP) Division of Water (KDOW) regulates dam design, construction and repair. The Kentucky Department for Natural Resources and Environmental Protection’s (KDEP) Division of Water (KDOW) regulates dam design, construction and repair. KDOW also evaluates a dam’s structure and various other criteria related to the effects of dam failure to determine and assign a dam hazard classification to each structure. KDOW’s Engineering Memorandum No. 5 provides minimum hydrologic and hydraulics related design criteria, as well as hazard classification definitions for dam structures. Dam hazard classifications, outlined in KDOW’s Engineering Memorandum No. 5, include Low Hazard (A), Moderate Hazard (B), and High Hazard (C).

- A Low Hazard (A) classification is assigned to structures “located such that failure would cause loss of the structure itself but little or no additional damage to other property.”
- A Moderate Hazard (B) classification is assigned to structures that “are located such that failure may cause significant damage to property and project operation, but loss of human life is not envisioned.”
- A High Hazard (C) classification is assigned to “structures located such that failure may cause loss of life or serious damage to houses, industrial or commercial buildings, important public utilities, main highways or major railroads.”

According to KDOW, state inspections for dams with high (Class C) and moderate classifications (Class B) occur every two years, while dams with a low hazard classification (Class A) are inspected every five years. A Certification of Inspection is issued to the dam owner if, upon inspection, it is determined that the as-built structure meets all the necessary requirements as outlined in KDOW’s Engineering Memorandum No. 5. Following successful construction completion and inspection, the owner is given permission to impound water and the dam is placed on the KDOW inventory of dams.

KDOW has classified Ash Treatment Basin #1 (ID803) and Scrubber Pond (ID 804) as low hazard dams (Class A). According to the KDOW inspection document dated November 22, 2004, the Ash Treatment Basin #2, Finishing Pond #3, and the Former Ash Pond (Coal Runoff Pond) do “not meet the regulatory requirements and definition attributed to a ‘dam’”. Due to location, ash settlement and flow characteristics, operational methods of ash handling and lack



of downstream development, it does not appear that overtopping of these impoundments would feasibly create any hydraulic (flooding) hazard downstream.”

As part of the observations and evaluations performed at Green River Power Station, AMEC completed EPA’s Coal Combustion Dam Inspection Checklists and Coal Combustion Waste (CCW) Impoundment Inspection Forms. Copies of the CCW Impoundment Inspection Forms are provided in Appendix A. The CCW Impoundment Inspection Forms include a section that assigns a “Hazard Potential” that is used to indicate what would occur following failure of an impoundment. “Hazard Potential” choices include “Less than Low,” “Low,” “Significant,” and “High.” Based on the site visit evaluation of the impoundments, AMEC engineers assigned a “Significant Hazard Potential” classification to the Ash Treatment Basin #1 or Main Pond, Ash Treatment Basin #2, Scrubber Pond, and the Former Ash Pond or Coal Runoff Pond, and no classification was assigned to the Finishing Pond #3. As defined on the Inspection Form, dams assigned a “Significant Hazard Potential” classification are those dams where failure or mis-operation results in no probable loss of human life but can cause economic loss, environmental damage, disruption of lifeline facilities, or can impact other concerns. AMEC assigned the “Significant Hazard Potential” classification to these impoundments based on their proximity to Green River. AMEC did not assign a hazard potential classification to the Finishing Pond #3 because plant discharge flows have been rerouted and do not enter the pond; and, the dike has been removed.

EPA received Draft Report<sup>1</sup> response comments from KU (January 26, 2011) and KDOW (January 31, 2011). Both parties take exception to (1) the assignment of independent hazard potential ratings to the Green River Ash Treatment Basin #1 and Scrubber Pond (both considered to be dams of low hazard potential by Kentucky regulations) and the Ash Treatment Basin #2 and Coal Runoff Pond (not considered ‘dams’ according to Kentucky criteria) and (2) criteria for assignment of the rating. AMEC utilized the resources and guidelines provided by EPA for this work.

### 1.2.1 State Issued Permits

The Kentucky Natural Resources and Environmental Protection Cabinet Department for Environmental Protection Division of Water has issued Kentucky Pollutant Discharge Elimination System (KPDES) Permit No. KY 0002011 to Kentucky Utilities Company. This KPDES Permit authorizes Kentucky Utilities to discharge from Green River Power Station into the Green River at mile points 81.3 and 81.6. The permit became effective on November 1, 2001 and expired on October 31, 2004. At the time of writing this report, KDOW stated the KPDES permit for Green River Power Station was under review. Additionally, KDOW stated the permit remains in effect, under applicable state regulations, while under review.

### 1.3 Site Description and Location

Kentucky Utilities Green River Power Station is located in Muhlenburg County, KY, approximately 6 miles north of Central City, Kentucky. The area surrounding the plant boundary is primarily rural. The Green River is located to the south of the plant facilities. The distances between the closest point of the ash ponds and the Green River is approximately 400 feet for the coal pile runoff pond, and 75 feet for the Finishing Pond #3 (currently inactive pond). The Site Plan, included as Figure 2, shows the location of the ash ponds and their proximity to the Green River.

---

<sup>1</sup> AMEC submitted Draft Report to EPA in September 2010

An aerial photograph of the region indicating the location of Green River Power Station ash ponds in relation to schools, hospitals, and other critical infrastructure located within approximately 5 miles down gradient of the structures is included as Figure 3, the Critical Infrastructure Map. A table that provides names and coordinate data for the infrastructure is included on the map. Site topography is illustrated on Figure 4.

## 1.4 Process Ponds

### 1.4.1 Ash Handling and Flow Summary

Green River Power Station utilizes coal in the production of electricity. In this process, two types of CCW ash are generated: bottom ash and fly ash. The Green River plant manages coal pile runoff and coal combustion waste using two Ash Treatment Basins (ATBs), a Coal Pile Runoff basin and a Flue Gas Desulfurization (FGD) Scrubber Pond.

Process flows to the ash basin primarily result from the operation of Green River Units 3 and 4 as well as management of residuals formed by the combustion of coal including:

- Fly ash and bottom ash sluicing flows;
- Coal mill rejects and pyrites;
- Boiler blowdown flows;
- Water demineralizer regeneration wastes and reverse osmosis system reject water flows;
- Miscellaneous filter backwash and floor drain flows (from plant sumps);
- Sewage treatment plant effluent flows;
- Miscellaneous once-thru cooling water flows; and,
- Coal pile runoff flows.

Once-through cooling water flows are used for the Units 3 and 4 condensers and are not routed through the ash basins. Instead, these flows are directed to the Green River downstream of the plant water intakes and buildings through a dedicated discharge stream. This flow also receives drainage from roof drains and intake filter backwash flows. The existing KPDES permit for the station addresses all of these flows. This includes monitoring requirements, limits and other conditions.

Documents provided by E.ON U.S. noted that the rainfall runoff areas to the ash basin include:

- Plant coal pile equipment maintenance areas located south of the plant boiler-turbine building;
- The coal pile runoff area. Runoff is collected in an approximately 5 acre pond which drains to the Ash Treatment Basin #2;

- Rainfall runoff flows associated with the watershed basin of the pond itself;
- Runoff from miscellaneous process areas of the plant include oil storage and delivery areas which are routed through an oil/water separator and the coal pile runoff pond prior to discharge to the Ash Treatment Basin #2.

#### 1.4.2 Ash Treatment Basin #1

The Ash Treatment Basin #1 (Main Ash Pond) has an inside surface area of approximately 32 acres and receives process flows from plant operations and rainfall runoff flows. The basin discharges from a rectangular reinforced concrete decant structure that has stop-logs to control the pond water level. A floating skimmer upstream of the decant structure prevents potential discharge of floating solids or oil sheens. The discharge flow is conveyed to Ash Treatment Basin #2 through an open channel.

##### Current Pond Conditions

The Ash Treatment Basin #1 was constructed in 1977. The impoundment consists of three embankments along the east, south and west side of the pond. The north limits of the east and west embankments intersect a native hill. The total length of constructed embankment is approximately 2,700 linear feet. The design crest elevation is 450 feet National Geodetic Vertical Datum of 1929 (NGVD) with a crest width of about 20 feet. The bottom of pond elevation is approximately 395 feet NGVD. The lowest toe elevation at the maximum section is approximately 400 feet NGVD resulting in a maximum dam height of approximately 50 feet. The downstream slope faces are nominally reported to be 2.5H:1V (horizontal to vertical) and the upstream slopes (wet side) are nominally 2H:1V. Figures 5 and 6 illustrate the Green River Main Ash Pond Plan View and Typical Cross Sections. According to KU, the dam was constructed under the supervision of James Flaig, PE as identified on the HC Nutting as built project drawings provided to AMEC. Documentation also indicates the dam was designed and is currently inspected by a professional engineer.

##### Previous Pond Issues

It is AMEC's understanding that the southern embankment of Ash Treatment Basin #1 southern has experienced two slope failures. During the site investigation, AMEC observed a buttress had been constructed on the downstream slope of the dam beginning approximately 200 feet northeast of piezometer P3A. This structure is not shown on the original H.C. Nutting drawings and no other records could be located. However, it is known to have been constructed to repair a previous slope failure. The second slope failure occurred in November 2009. A July 14, 2010 report entitled *Final Geotechnical Report, Main Ash Pond, Slope Stability Analysis and Repair, Green River Station*, prepared by Associated Engineers, Inc., discusses the stability of the entire Main Ash Pond dam along with analysis and design recommendations specific to the recent (2010) slope repair activities. Within the report the slope failure cause was described as follows;

*Based on the available data, the probable triggering mechanism of the slope failure was excessive moisture originating from a combination of factors including subtle grading at the top of the dam which directs drainage down the slope in this area, and possible focused surface and subsurface drainage along the base of the dam from the northeast due to topographic influence. Rutting and surface scaring that appeared to have occurred during mowing operations, along with*

*poor vegetative cover conditions were also probable causation factors. High moisture conditions appeared to be restricted to a limited area in the outer portion of the dam material near the base and did not extend into the interior of the dam construction material. The lower portions of the fly ash and underlying dark grayish brown silty clay were wet and exhibited N-values of 6 to 8. Moisture may be contributed by these units but they were not part of the existing slump feature.*

The southern slope of the Main Ash Pond was repaired in May and June of 2010 by excavating and removing loose materials and reconstructing the slope with rock. The recommendations were outlined in Associated Engineers report and are summarized below.

1. Excavate the cut slope on a 1:1 slope and reconstruct with rock on a 2:1 slope.
2. Place Geotextile Fabric, Type IV on excavated soil area meeting the requirements of Section 843, Type IV, of the current edition of the Kentucky Transportation Cabinet, Standard Specifications for Road and Bridge Construction (Appendix E). Install Geotextile Fabric according to Section 214 of the Standard Specifications for Road and Bridge Construction (Appendix E). Prepare the surface to a smooth condition, free of obstructions, debris, or sharp objects that may puncture the fabric. Place the fabric smooth and free of tension, stress, folds, wrinkles, or creases. Do not operate equipment directly on the fabric. Overlap strips at least 18 inches. Place transverse laps so the upslope strip laps over the downslope strip. Install fastener pins through both strips of overlapped fabric at no less than 5-foot intervals along a line through the midpoint of the overlap, and at any other locations as necessary to prevent any slippage of the fabric. Place fabric with the long dimension parallel to the long dimension of the section to be covered.
3. Install a 6" perforated pipe as shown on the plans. Place outlet at the lowest point of the excavation.
4. Use Kentucky Coarse Aggregate No. 2's, 3's, or 23's meeting the requirements of Sections 703 and 805 of the Standard Specifications for Road and Bridge Construction (Current Edition).

Associated Engineers noted in their report that their services were requested on May 18, 2010 to observe the repair construction of the slope failure area. A final inspection was performed on June 17, 2010 with Associated Engineers noting the only remaining issues were grouting of the toe drain pipe at the headwall and seeding and strawing at the toe of the repaired area.

In comments provided subsequent to submittal of the September 2010 Draft Report, KU notes that:

*The Green River Ash Treatment Basin #1 slope failures were shallow, maintenance type sloughs, commonly associated with earthen dams. KU promptly took action to repair these areas. Qualified KU staff routinely monitors these areas and the repairs have continued to perform satisfactorily.*

### 1.4.3 Ash Treatment Basin #2

The Ash Treatment Basin #2 has an inside surface area of approximately 23 acres and receives flows from the Ash Treatment Basin #1, coal pile runoff pond, and rainfall runoff. Depending on seasonal rainfall, accumulated rainfall waters are also pumped from the Scrubber Pond to the Ash Treatment Basin #2. The discharge of this pond flows through a rectangular reinforced concrete decant structure consisting of stop-logs to control the pond water level. A floating skimmer upstream of the decant structure prevents potential discharge of floating solids or oil sheens. Flow is directed to the Kentucky Pollution Discharge Elimination System (KPDES) monitoring and sampling point. This monitoring/sampling point consists of a concrete structure with a rectangular concrete weir. Flow from the monitoring/sampling point structure discharges to a rip-rap lined open channel which directs flow to the Green River downstream of the plant buildings. Plant operations staff manages the pool elevation by adjusting stop log elevations as necessary to maintain freeboard.

#### Current Pond Conditions

Ash Treatment Basin #2 was formed out of the original plant "Settling Basin" constructed in 1949. In the 1970s, the south embankment of the original pond was expanded to the east and north, and a divider dike was constructed to create a two-cell pond. The east pond is referred to as the Ash Treatment Basin #2 which intersects the native hill side at the northern limit of the pond. The total length of constructed embankments for this complex is approximately 2,500 linear feet. The typical crest elevation for the Ash Treatment Basin #2 is 400 feet National Geodetic Vertical Datum of 1929 (NGVD) with a typical crest width of about 15 feet (per ATC inspection report dated October 2009). The bottom of pond elevation is approximately 385 feet NGVD. The downstream toe elevation varies with the lowest toe elevation of 385 feet NGVD resulting in a maximum dam height of approximately 15 feet. The downstream slopes are reported to be nominally 2H:1V (horizontal to vertical) and the upstream slopes (wet side) are nominally 2H:1V. The pond, as it exists with an embankment height of 15 feet and surface area of 23 acres, has a potential impoundment capacity of 345 acre-feet. That impoundment potential exceeds the KDOW minimum requirement (50 acre-feet) for qualification as a 'dam'. However, as noted previously, Ash Treatment Basin #2 is not currently identified by KDOW as a 'dam'.

A plan view of Ash Treatment Basin #2 is provided on Figure 4; and, typical cross sections are illustrated on Figure 6. Kentucky Utilities was unable to determine if the dam was designed and constructed under the supervision of a professional engineer, however documentation indicates the dam is currently inspected by a professional engineer.

### 1.4.4 Finishing Pond #3

A Tertiary pond, Finishing Pond #3, previously maintained by the plant, was located downstream of the Ash Treatment Basin #2 immediately prior to final discharge into the Green River. The plant did not directly discharge ash or plant process materials into the pond; however, the pond has received carryover of coal combustion residual materials. Because the KPDES monitoring-sampling point was upstream of the pond, the pond had no functional necessity and was removed from service in 2010. Removal from service included:

- Rerouting the Ash Treatment Basin #2 discharge and KPDES monitoring-sampling point channel around the Tertiary pond and directly into the final KPDES Outfall discharge into the Green River. This rerouted channel is lined with a non-woven

geotextile fabric installed beneath 12 inches of 4-6 inch diameter crushed limestone rip-rap;

- Regrading constructed embankment such that there is no feature present to impound water. Regrading included installation of crushed limestone blankets to control erosion;
- Removal of obsolete outlet structure; and,
- Regrading the former pond area to promote vegetation growth; and installing erosion control measures such as grass seeding, straw and silt fence.

Figures illustrating historic or current conditions of Finishing Pond #3 were not included in this report as documentation was not provided in a manner that would allow for clear representation of the pond's existing condition.

#### **1.4.5 Scrubber Pond**

The Scrubber Pond has an inside surface area of approximately ten acres and has not received process water since 2003 due to retirement of Units 1 and 2 and their flue gas desulfurization (FGD) systems. The pond remains available for possible future FGD material storage if necessary for Units 3 and 4. Previously the pond received FGD slurry material by pipelines. The solids settled, and the water was recycled for use in the FGD system. Currently, the pond accumulates rainfall. Plant operations staff manages the pool elevation by pumping to the Ash Treatment Basin #2. According to information provided by KU following submittal of the Draft Report in September 2010, new pumps with automatic switches were installed in the Scrubber Pond to provide automatic pool elevation control. These pumps were installed in December 2010.

##### Current Pond Conditions

The Scrubber Pond (also known as the SO<sub>2</sub> Removal Pond) was constructed in 1975 to manage FGD residuals for Green River Power Station Units 1 and 2, and since these units retirement in 2003 the Scrubber Pond has not received FGD residuals. The impoundment consists of three embankments along the east, south and west side of the pond. The north limits of the east and west embankments intersect a native hill. The total length of constructed embankment is approximately 2,000 linear feet. The design crest elevation is 405 feet National Geodetic Vertical Datum of 1929 (NGVD) with a crest width of 10 feet. The bottom of pond elevation is approximately 385 feet NGVD. The downstream toe elevation varies with the lowest toe elevation of 385 feet NGVD resulting in a maximum dam height of approximately 20 feet. The upstream and downstream slope faces were designed to be 2.5H:1V (horizontal to vertical).

A plan view of the Scrubber Pond is provided on Figure 4; and, typical cross sections are illustrated on Figure 7. Kentucky Utilities was unable to determine if the dam was constructed under the supervision of a professional engineer, however documentation indicates the dam was designed and is currently inspected by a professional engineer.

#### **1.4.6 Coal Pile Runoff Pond**

The coal pile runoff basin has an inside surface area of approximately six acres and drains into the Ash Treatment Basin #2. In addition to the coal pile runoff, the pond receives plant sump/process flows from the oil-water separator and sewage treatment plant.

### Current Pond Conditions

The Coal Pile Runoff Basin was formed out of the original plant "Settling Basin" constructed in 1949. In the 1970s, the south embankment of the original pond was expanded to the east and a divider dike was constructed to create a two-cell pond. The west pond is referred to as the Coal Pile Runoff Pond which intersects the native hillside at the northern limit of the pond. The total length of constructed embankments for this complex is approximately 1,200 linear feet. The typical crest elevation for the Coal Pile Runoff Pond is 405 feet National Geodetic Vertical Datum of 1929 (NGVD) with a typical crest width of about 15 feet. The bottom of pond elevation is approximately 385 feet NGVD resulting in a maximum dam height of approximately 20 feet. The downstream slope faces are nominally reported to be 2H:1V (horizontal to vertical) and the upstream slopes (wet side) are nominally 2.2H:1V.

A plan view of the Coal Pile Runoff Pond is provided on Figure 4; and, typical cross sections are illustrated on Figure 8. Kentucky Utilities was unable to determine if the dam was designed or constructed under the supervision of a professional engineer, however documentation indicates the dam is currently inspected by a professional engineer.

### **1.5 Previously Identified Safety Issues**

Discussions with plant personnel and review of provided documentation indicate that except for the repaired surface slope stability issues previously mentioned for the Main Ash Pond (Section 1.4.2), there are no other current or previously identified safety issues from the previous 5 years at Green River Power Station.

### **1.6 Site Geology**

H.C. Nutting Company completed a geotechnical report entitled *Report of Geotechnical Investigation, Phase I, Proposed Fly Ash Disposal Area, Green River Power Station, For Kentucky Utilities Company, Inc.*, dated May 2, 1975. Within the report the site geology was described as follows;

*The plant is located more or less in the north central part of Muhlenberg County, Kentucky immediately north of the Green River and approximately 6 miles north of Central City, Kentucky. The site is situated near the center of the Western Kentucky coal fields. The bedrock underlying the site is part of the Pennsylvanian System of the upper Pennsylvanian Series. The geologic maps indicate the No. 15 coal bed to outcrop at approximately elevation 450 ± and the No. 14A and No. 14 coal bed at some depth below elevation 390. The upper Pennsylvanian bedrocks at the site consist of sandstone, shale, coal and under clay. The predominant material is shale and sandstone. The shales range from clay shale to silty shales to sandy shales. The sandstones are typically fine to medium grained, micaceous, generally soft and friable, then to thick bedded and commonly irregularly bedded and cross bedded. The sandstones are usually massive where weathered.*

*The proposed ash retention area (Main Pond) is located on the foot slopes of the bedrock hills forming the north or northwest wall of the Green River valley. The flat area (valley floor) immediately south of (below) the proposed dam location consists of moderately deep alluvial clays, silts and fine sands above the buried bedrock.*

*During the geologic past there has been considerable faulting in Muhlenberg County; however, none have been mapped within about five miles of the site.*

## **1.7 Inventory of Provided Materials**

Kentucky Utilities provided AMEC with numerous documents pertaining to the design and operation of Green River Power Station. These documents were used in the preparation of this report and are listed in Appendix C, Inventory of Provided Materials.



## 2.0 FIELD ASSESSMENT

### 2.1 Visual Observations

AMEC performed visual assessments of Green River Power Station's five ash pond units on August 16, 2010. Assessment of the ash ponds was completed in general accordance with *FEMA's Federal Guidelines for Dam Safety, Hazard Potential Classification System for Dams, April 2004*. The EPA Coal Combustion Dam Inspection Checklist and Coal Combustion Waste (CCW) Impoundment Inspection Forms were completed for each ash pond during the site visit. The completed forms were provided to the EPA via email three days following the site visit. Copies of the completed checklists are included in Appendix A. In addition to completing the checklist and assessment forms, photographs were taken of each impoundment during the site visit. Photo site location maps and descriptive photos are included in Appendix B.

To maintain consistency with the utility and other associated reports/inspections, directions used herein are based on plant north (river is south) instead of true north (located approximately 45 to 60 degrees to the right).

### 2.2 Ash Treatment Basin #1 (Main Ash Pond) - Visual Observations

The Ash Treatment Basin #1 (ATB 1) is currently active and receives/contains fly ash and bottom ash. The pond is also referred to as Main Ash Pond.

#### 2.2.1 Ash Treatment Basin #1 - Embankments and Crest

The ash pond has a side-hill configuration; and, a freeboard of approximately 4.5 feet between the top of water and top of dike was observed during the site visit (photo M-13). Original ground above the elevation of the pond is to the north. Dikes are present on the west, south and east sides of the pond. The crest of the dam and upstream slopes of the west and south dikes were primarily surfaced with crushed stone (photos M-1, M-6, M-8, and M-17). The surface of the downstream slopes of the dikes and the upstream slope of the east dike was primarily covered with grass (photos M-2, M-5, and M-17). Sparse grass cover was observed on the downstream slope of the west dike (photo M-2). Ash was observed to be stacked to a height just below the crest of the south dike at the southwest end of the pond (photo M-3). Two above ground pipes for sluicing ash to the pond are located on the west portion of the south dike. The pipes traverse the downstream slope of the south dike then cross the crest through a concrete culvert (photos M-25 and M-8). Two buttresses, reportedly installed due to shallow surface failures, were observed on the downstream slope of the south dike, one on the west (compacted soil construction) and one on the east (rock construction) portions of the dike (photos M-9 and M-12). The buttresses reportedly include drains which are tied to a collector pipe and directed to the toe of the slope. Flowing water was observed from the outlet of the west buttress; however, flowing water was not observed at the east outlet (photos M-24 and M-21). Sparse grass cover and uneven slopes were observed on the mid-section of the downstream slope of the south dike beginning at the west buttress and extending for about 300 feet to the east (photo M-23). A stockpile of sand and gravel was observed at the north end of the east dike (photo M-20). Trees appeared to be growing within the interior at the northeast end of the pond, but they may be growing on fingers of original ground extending into the interior from the north (photo M-20). Old matting and straw was observed on the downstream slope of the west dike. Reportedly, the slope was seeded and matted last fall but weather killed most of the planting. Kentucky Utilities stated they had bid out a contract to reseed the slopes this fall.

## 2.2.2 Ash Treatment Basin #1 - Outlet Control Structure

The primary outlet for Ash Treatment Basin #1 is a concrete structure located adjacent to the south dike at the east end of the pond (photo M-10). The concrete structure supports a floating perimeter skimmer and adjustable stop log unit that facilitates water level adjustments as needed, based on plant operations (photos M-13, M-14, and M-15). Flow from this primary outlet structure is conveyed through a 36-inch diameter reinforced concrete pipe to the discharge point which is located at the downstream toe of the south dike (photos M-12 and M-22). Erosion along the sides of the outlet sidewall was observed during the field visit (photo M-22). The outfall from Ash Treatment Basin #1 flows south in an open ditch and discharges into Ash Treatment Basin #2 (photo M-12).

## 2.3 Ash Treatment Basin #2 - Visual Observations

Ash Pond 2, or Ash Treatment Basin #2 (ATB 2), is located adjacent and to the east of the Coal Pile Runoff Pond (photo CR-6). Ash Pond 2 receives discharge from the Main Pond, the Coal Pile Runoff Pond and periodically from the Scrubber Pond.

### 2.3.1 Ash Treatment Basin #2 - Embankments and Crest

Ash Treatment Basin #2 has a diked configuration with a connection to natural ground located on the north end of the basin. Ash is currently stacked on the southwest end of the pond and the northeast portion, approximately 40% of the total pond area, is water (photos 2-1 and 2-11). A freeboard of approximately 3 feet between the top of water and top of dike was observed during the site visit (photo 2-11). The west dike is common with the Coal Pile Runoff Pond. The crest of the dam was surfaced with crushed stone (photos CR-8, 2-1, and 2-8). Upstream slopes of the dike were covered with grass and/or rock (photo 2-1, 2-2, and 2-8). Except for approximately one-half of the length of the slope on the west end of the south dike, the downstream slopes were covered with rock (photos 2-3, 2-9, and 2-10).

### 2.3.2 Ash Treatment Basin #2 - Outlet Control Structure

The outlet structure for Ash Treatment Basin #2 consists of a concrete riser structure located on the north end of the east dike. The riser structure supports a floating metal pipe and rubber perimeter skimmer and an adjustable stop log unit that facilitates water level adjustment as needed, based on plant operations (photos 2-11 and 2-12). A 30-inch diameter culvert pipe empties the riser into a concrete box that is located beyond the toe of the downstream embankment. The concrete box contains a fixed overflow weir, most likely used as a flow measurement device for the permitted NPDES discharge location 001 (photos 2-13 and 2-14). The flow then enters a rock lined channel that ultimately discharges to Green River (photos 2-6 and 2-16). KU representatives present during the field visit indicated the roadway was the south embankment for the Coal Pile Runoff Pond and Ash Pond 2. A distinct drop in elevation was observed on the south dike/road at Ash Treatment Basin #2 (photo 2-4). An interior mound of ash located north of the south dike appeared to carry the same top of dike elevation from the Coal Pile Runoff Pond (photos 2-1, 2-2, 2-3, and 2-4). If the road is the dike, the interior mound of ash is above the dike elevation.

## 2.4 Finishing Pond #3 - Visual Observations

Finishing Pond #3 is located to the south of Ash Treatment Basin #2 and north of the Green River. Formerly, Finishing Pond #3 was used as a finishing pond (below the NPDES outfall)

prior to discharging the site water to the Green River. The Ash Treatment Basin #3 dike was located to the south, west, and east. The dike has been removed/regraded and the resulting area armored with rip-rap, hence, Ash Treatment Basin #3 is no longer in service. Photos of the current site outlet pipe and ditch, which are located to the east of pond, former area of the pond, and regraded dike are presented in photos SP-1, SP-2, and SP-3.

#### **2.4.1 Finishing Pond #3 - Embankments and Crest**

The dike for Finishing Pond #3 has been regraded. This pond is considered to be no longer in service. It is our understanding ash was not removed from within the interior of the pond when the dike was removed.

#### **2.4.2 Finishing Pond #3 - Outlet Control Structure**

The dike for Finishing Pond #3 has been regraded, the pond taken out of service, and it does not presently have an outlet structure.

### **2.5 Scrubber Pond - Visual Observations**

The Scrubber Pond is located to the east of Ash Treatment Basin #2. The Scrubber pond is active but does not receive liquid-borne CCW materials. The scrubber pond receives rainfall and surface water runoff and the water level is adjusted about twice a year.

#### **2.5.1 Scrubber Pond - Embankments and Crest**

The Scrubber Pond has a side-hill/incised configuration. The connection to natural ground at the Scrubber Pond is located on the pond's north side. Ash is currently stacked on the pond's north and south ends, with water in approximately 60% of the total pond area (photo SP-4). A freeboard of approximately five feet between the top of the water and top of the south dike was observed during the site visit (photo SP-3). The upstream embankment is covered with grass (photos SP-1, SP-2, SP-5, SP-6, and SP-7). The crest of the dam was surfaced with crushed stone (photos SP-1, SP-2, SP-5, SP-6, and SP-7). The surface of the downstream embankment was also covered with grass (photos SP-8, SP-10, SP-11, SP-12, and SP-13). Ash within the pond was observed to be approximately one foot below the elevation of the west dike (photo SP-1). An uneven elevation across the crest (dipping to the interior) was also observed along the west dike (photo SP-1). Ash and/or piles of debris were observed above the elevation of the north dike (photo SP-2). Uneven/steepened slopes were observed on the upstream slopes of the south and east dikes (photos SP-5 and SP-6). This condition was reportedly caused by recent use of equipment to remove or flatten vegetation on or near the slope. Areas with sparse vegetation were observed on the downstream slopes of the west, south and east dikes (photos SP-8, SP-10, SP-11, and SP-12). A recent repair of a small surface slide was observed on the downstream slope near the southwest corner of the pond (photo SP-10). Repairs at and below the toe of the downstream slope were observed at the west end of the south dike (photo SP-11).

#### **2.5.2 Scrubber Pond - Outlet Control Structure**

The scrubber pond does not have a formal outlet structure. The means to remove water from the pond is via a floating pump platform located at the southwest end of the pond (photo SP-3). It has been reported that the pond receives only rainfall and surface water; and, that the pond is pumped down about twice a year with the outflow discharging to Ash Treatment Basin #2.

## 2.6 Coal Pile Runoff Pond - Visual Observations

The Coal Pile Runoff Pond is located below and to the southwest of the Main Ash Pond (photo M-9). The pond was a former ash pond for the plant; however, it now serves to receive surface water runoff from an adjacent coal pile, located to its west, and other liquid forms of plant waste. The east dike of the Coal Pile Runoff Pond is a common dike with Ash Treatment Basin #2.

### 2.6.1 Coal Pile Runoff Pond - Embankments and Crest

The Coal Pile Runoff Pond generally has a diked configuration with dikes on the west, south and east embankments and a tie-in to natural ground located to the north. Ash is currently stacked on the south half of the pond and the north half is water (photos CR-3 and CR-9). A freeboard of approximately three feet between the operating water surface and the east dike crest was observed during the site visit (photo CR-4). The crest along the south and east dikes of the pond is covered with crushed stone (photos CR-2, CR-3, and CR-10). The surface of the upstream and downstream embankments was covered with grass (photos CR-1, CR-3, and CR-10). The downstream slope of the south dike (road) was observed to be steep with areas of sparse grass cover (photo CR-1). The west side of the pond is higher ground from the coal pile and includes a separating berm associated with the coal pile (photos CR-5 and CR-9).

### 2.6.2 Coal Pile Runoff Pond - Outlet Control Structure

The primary outlet for the Coal Pile Runoff Pond is located at the northeast end of the pond (photo CR-4). The outlet consists of a metal and boom perimeter skimmer and a corrugated metal pipe (photo CR-7). Flow from the outlet pipe is conveyed through the embankment to discharge into Ash Treatment Basin #2 (photo CR-8).

## 2.7 Monitoring Instrumentation

Historically, impoundment monitoring equipment has not been used at the Green River Power facility. However, new piezometers were recently installed at Ash Treatment Basin #1 (5), the Coal Pile Runoff Pond (1), Ash Treatment Basin #2 (3), and the Scrubber Pond (3). Operating data was not submitted in reference to the piezometers due to their recent installation.

The Green River Ash Treatment Basin #1 and Ash Treatment Basin #2 were designed and constructed with weirbox structures and metal plate v-notch weirs at the ash pond flow measurement structure.

### 3.0 DATA EVALUATION

#### 3.1 Design Assumptions

This section provides a summary of accepted minimum design criteria for dams and impoundments with respect to hydrologic, hydraulic and stability design of those structures. The relevant, methodology, design criteria, data, and analyses information that was provided for the Green River Power Station concerning hydrologic and hydraulic issues, as well as for structural adequacy and stability issues, is then presented and compared to the accepted minimum industry criteria.

#### 3.2 Hydrologic and Hydraulic Design

##### KDOW

The Kentucky Department for Natural Resources and Environmental Protection, Division of Water, Engineering Memorandum No. 5 (EM No. 5), Section C, provides minimum hydrologic design criteria for all dams, as defined by KRS 151.100, and all other impounding obstructions which might create a hazard to life or property, that are constructed within the state of Kentucky. EM No. 5 provides equations to determine the minimum hydrologic criteria to be used in the development of emergency spillway and freeboard hydrographs for the structures. Definitions provided in EM No. 5 for these hydrographs are as follows:

“The emergency-spillway hydrograph is that hydrograph used to establish the minimum design dimensions of the emergency spillway.”

“The freeboard hydrograph is the hydrograph used to establish the minimum elevation of the top of the dam.”

Precipitation values to be used in determination of the emergency and freeboard hydrographs for low, moderate, and high hazard class dams are provided by EM No. 5 and are as follows.

##### Emergency Spillway Hydrograph

$$\text{Class (A) Low Hazard Structure} \quad P_A = P_{100} \quad (1)$$

$$\text{Class (B) Moderate Hazard Structure} \quad P_B = P_{100} + [0.12 \times (\text{PMP} - P_{100})] \quad (2)$$

$$\text{Class (C) High Hazard Structure} \quad P_C = P_{100} + [0.26 \times (\text{PMP} - P_{100})] \quad (3)$$

##### Freeboard Hydrograph

$$\text{Class (A) Low Hazard Structure} \quad P_A = P_{100} + [0.12 \times (\text{PMP} - P_{100})] \quad (4)$$

$$\text{Class (B) Moderate Hazard Structure} \quad P_B = P_{100} + [0.40 \times (\text{PMP} - P_{100})] \quad (5)$$

$$\text{Class (C) High Hazard Structure} \quad P_C = \text{PMP} \quad (6)$$

where, P refers to 6-hour precipitation,  $P_{100}$  refers to 6-hour, 100-year precipitation, and PMP refers to 6-hour Probable Maximum Precipitation.

According to EM No. 5, the freeboard hydrograph rainfall depth established by the equation “does not eliminate the need for sound engineering judgment but only establishes the lowest limit of design considered acceptable.” Several sources are provided in EM No. 5 regarding where to obtain rainfall values to use in the equations. Engineering Memorandum No. 2 (EM No. 2), issued by KDOW and last revised on June 1, 1979, is entitled “Rainfall Frequency Values for Kentucky”, and is noted as an acceptable data source for rainfall data for locations in Kentucky.

With respect to the principal spillway, EM No. 5 states that “It is desirable that the retarding pool be emptied in ten (10) days or less. It may be assumed that this requirement has been met if eighty (80) percent of the maximum volume of retarding storage has been evacuated in the ten (10) day period.” KDOW defines retarding pool at “the reservoir space allotted to the temporary impoundment of floodwater. Its upper limit is the elevation of the crest of the emergency spillway.” According to discussions with KDOW Dam Safety personnel, in the absence of an emergency spillway, the upper limit would be considered to be the crest of the dam.

Emergency spillway hydrographs are to be routed “through the reservoirs beginning at the water surface elevation of the principal spillway or the water surface elevation after 10 days drawdown, whichever is greater.” Class (A) and (B) structures shall have freeboard “routed through the structure beginning at the same water surface elevation as for the emergency spillway hydrograph.” The crest of the principal spillway shall be the starting point for routing hydrographs for Class (C) structures.

With respect to structures located in series, Section B.II of EM No. 5 states when “structures are spaced so that the failure of an upper structure could endanger the safety of a lower structure, the possibility of a multiple failure must be considered assigning the structure classification of the upstream structure. Additional safety can be provided in either structure by (1) increasing the retarding storage and/or (2) increasing the emergency spillway.” Additionally, Section C.I.A describes hydrologic criteria for structures in series. With respect to structures located in series, Section B- II of EM No. 5 states;

*When structures are spaced so that the failure of an upper structure could endanger the safety of a lower structure, the possibility of a multiple failure must be considered [when] assigning the structure classification of the upstream structure. Additional safety can be provided in either structure by (1) increasing the retarding storage and/or (2) increasing the emergency spillway.*

Additionally, Section C.I.A of EM No. 5 describes hydrologic criteria for structures in series. The memo states that;

*For the design of a lower structure in series, if the total drainage area above a lower structure exceeds 10 square miles and Section B-II of this memorandum applies, it is necessary to apply two sets of storms for the development of both the emergency spillway and the freeboard hydrographs.*

The memo continues by describing the selection criteria for the two sets of storms and notes that the designer should use the storm which results in the “most severe flow condition” at the lower structure.

Additional discussions with the Dam Safety Division of KDOW indicate that in that absence of an emergency spillway, the crest of the dam is considered the uppermost elevation. A

temporary water surface may exist within an impoundment as a result of the design storm occurrence; however, the discharge structure must be shown to be capable of returning the water surface elevation to normal levels within 10 days following the storm. Routing hydrographs are necessary to show the discharge capabilities of the principal spillway within the structure. Stability analyses that reflect adequate stability for the “pond full” condition are also important.

Mine Safety and Health Administration

Chapter 8 - Impoundment Design Guidelines of the Mining Safety and Health Administration (MSHA) Coal Mine Impoundment Inspection and Plan Review Handbook (Number PH07-01) published by the U.S. Department of Labor, Mine Safety and Health Administration, Coal Mine Safety and Health, October 2007 provides another source for minimum hydrologic design criteria.

When detailing impoundment design storm criteria, MSHA states that dams need “to be able to safely accommodate the inflow from a storm event that is appropriate for the size of the impoundment and the hazard potential in the event of failure of the dam.” Additionally, MSHA notes that sufficient freeboard, adequate factors of safety for embankment stability, and the prevention of significant erosion to discharge facilities, are all design elements that are required for dam structures under their review. Additional impoundment and design storm criteria are as shown in Table 2, MSHA Minimum Long Term Hydrologic Design Criteria.

**Table 2. MSHA\* Minimum Long Term Hydrologic Design Criteria**

Hazard Potential	Impoundment Size	
	< 1000 acre-feet < 40 feet deep	≥ 1000 acre-feet ≥ 40 feet deep
Low - Impoundments located where failure of the dam would result in no probable loss of human life and low economic and/or environmental losses.	100 - year rainfall**	½ PMF
Significant/Moderate - Impoundments located where failure of the dam would result in no probably loss of human life but can cause economic loss, environmental damage, or disruption of lifeline facilities.	½ PMF	PMF
High - Facilities located where failure of the dam will probably cause loss of human life.	PMF	PMF

\*Mining Safety and Health Administration (MSHA) Coal Mine Impoundment Inspection and Plan Review Handbook (Number PH07-01) published by the U.S. Department of Labor, Mine Safety and Health Administration, Coal Mine Safety and Health, October 2007

\*\*Per MSHA, the 24-hour duration shall be used with the 100-year frequency rainfall.

Probable maximum flood (PMF) is, per MSHA, “the maximum runoff condition resulting from the most severe combination of hydrologic and meteorological conditions that are considered reasonably possible for the drainage area.” Additionally, MSHA notes the designer should consider several components of the PMF that are site specific. These components are said to include: “antecedent storm; principal storm; subsequent storm; time and spatial distribution of the rainfall and snowmelt; and runoff conditions.” Basic agreement, it was noted, exists

between dam safety authorities regarding “combinations of conditions and events that comprise the PMF;” however, there are “differences in the individual components that are used.” MSHA provided the following as a “reasonable set of conditions for the PMF:

- Antecedent Storm: 100-year frequency, 24 hour duration, with antecedent moisture condition II (AMC II), occurring 5 days prior to the principal storm.
- Principal Storm: Probable maximum precipitation (PMP), with AMC III. The principal storm rainfall must be distributed spatially and temporally to produce the most sever conditions with respect to impoundment freeboard and spillway discharge.
- Subsequent Storm: A subsequent storm is considered to be handled by meeting the “storm inflow drawdown criteria,” as described subsequently in the document.

With regard to storm influent drawdown criteria, MSHA Impoundment Design Guidelines noted that:

*Impoundments must be capable of handling the design storms that occur in close succession. To accomplish this, the discharge facilities must be able to discharge, within 10 days, at least 90 percent of the volume of water stored during the design storm above the allowable normal operating water level. The 10-day drawdown criterion begins at the time the water surface reaches the maximum elevation attainable for the design storm. Alternatively, plans can provide for sufficient reservoir capacity to store the runoff from two design storms, while specifying means to evacuate the storage from both storms in a reasonable period of time - generally taken to be at a discharge rate that removes at least 90% of the second storm inflow volume within 30 days.....When storms are stored, the potential for an elevated saturation level to affect the stability of the embankment needs to be taken into account.*

In Mineral Resources Department of Labor Mine Safety and Health Administration Title 30 CFR § 77.216-2 *Water, sediment, or slurry impoundments and impounding structures; minimum plan requirements; changes or modifications, certification*, information relevant to the duration of the probable maximum precipitation is given. Sub-section (10) of 77.216-2 states that a “statement of the runoff attributable to the probable maximum precipitation of 6-hour duration and the calculations used in determining such runoff” shall be provided at minimum in submitted plans for water, sediment or slurry impoundments and impounding structures.

The definition of design freeboard, according to the MSHA Guidelines, is “the vertical distance between the lowest point on the crest of the embankment and the maximum water surface elevation resulting from the design storm.” Additionally, the Handbook states that “Sufficient documentation should be provided in impoundment plans to verify the adequacy of the freeboard.” Recommended items to consider when determining freeboard include “potential wave run-up on the upstream slope, ability of the embankment to resist erosion, and potential for embankment foundation settlement.” Lastly, the Handbook states, “Without documentation, and absent unusual conditions, a minimum freeboard of 3 feet is generally accepted for impoundments with a fetch of less than 1 mile.”

MSHA addresses structures in series in Section 2 of the Impoundment Design Guidelines by noting;



*For impoundments located in series, where failure of an upstream dam could contribute to failure of a downstream dam, assessment of the consequences of failure of the upstream dam must include the additional consequences of failure of any downstream dams. In such cases, the design storm for an upper impoundment must be equal to or greater than the design storm for the lower impoundment. Also, the design of a downstream impoundment must take into account the discharge from an upper impoundment, including a breach hydrograph, if appropriate, based on the design storm for the lower impoundment occurring over the entire contributing drainage area.*

### 3.2.1 2010 Hydrologic and Hydraulic Study

MACTEC Engineering and Consulting, Inc. completed a hydrologic analysis of the Ash Treatment Basin #2, Scrubber Pond and Coal Pile Runoff Pond as part of their August 12, 2010 report entitled *Assessment of Spillway Hydrologic Adequacy for the Coal Pile Pond, Ash Treatment Basin No. 2, and Scrubber Pond at Green River Generating Station*. The purpose of MACTEC's investigation was to assess hydrologic and hydraulic conditions associated with the spillway discharges from the Coal Pile Runoff Pond, Ash Treatment Basin #2, and the Scrubber Pond at the Green River Power Station and identify appropriate hydraulic criteria and facility modifications to meet those criteria.

According to the MACTEC report, the primary hydrologic analyses to evaluate the Ash Treatment Basin #2, Scrubber Pond, and the Coal Pile Runoff Pond spillways were completed using HEC-HMS, an event-based rainfall runoff model (Hydrologic Engineering Center, U.S. Army Corps of Engineers). Design storm events of various returns periods and of various durations, including 6 hours, 24 hours and 48 hours, were used in the analyses. MACTEC made note of the fact that additional resources used in the analysis included construction plans provided by KU, available topographic mapping, as well as field observations made by MACTEC. Curve numbers and times of concentration were developed to characterize the watershed.

#### Ash Treatment Basin #1

According to the MACTEC report, a dam permit has been issued for the Ash Treatment Basin #1 by the Kentucky Department of Natural Resources and Environmental Protection, Division of Water (KDWP-DOW). The dam has been classified as a Class A Low Hazard Dam. MACTEC noted in their report that while Ash Treatment Basin #1 is not a structure subject to investigation, analysis of the basin was required for their overall analysis due to the fact that discharges from this basin are routed through Ash Treatment Basin #2. Ash Treatment Basin #1 was found to have a minimum freeboard of 1.54 ft for the DNREP-DOW Class A freeboard design hydrograph (FDH) and a freeboard of 2.11 ft for the 100-year, 48-hour design storm event. According to the MACTEC report, the characteristics for the Ash Treatment Basin #1 are as follows:

*The drainage area to Ash Treatment Basin #1 is approximately 71 acres. The outflow from ATB 1 (Ash Treatment Basin #1) is through a concrete riser structure equipped with concrete stop-logs creating a 5.0-ft long weir. The stop-logs weir crest can be varied by adding or removing stop-logs, but normally has a crest elevation of 445.9 ft NAVD 1988 as indicated on topographic mapping (FMSM February 1998). The riser structure is connected to a 36-inch diameter*

concrete pipe culvert that conveys water overflow to ATB 2. There are no inflows to ATB 1 other than precipitation runoff.

Table 3 below identifies various existing and proposed elevation conditions related to the hydrologic analysis of Ash Treatment Basin #1 that were summarized in the MACTEC report.

**Table 3. 2010 Ash Treatment Basin #1 Elevation Conditions**

Elevation Condition	Elevation
Ash Treatment Basin #1, 100-yr, 48-hr Flood Elevation (ft)	447.29
Existing Dam Crest Minimum Elevation (ft)	449.40
Current Operating Water Surface Elevation (ft)	445.9
Current Operating Freeboard (ft)	449.40 - 445.9 = 3.5
100-year (48-hour) Flood Elevation Freeboard (ft)	2.11

According to the MACTEC report, the Ash Treatment Basin #1 would not experience an overflow event for the 100-year, 48-hour duration event.

Ash Treatment Basin #2

According to the MACTEC report, the characteristics for the Ash Treatment Basin #2 are as follows:

*ATB 2 receives discharges from the CPP, ATB 1, the SP, and a small upland drainage area. The total drainage area to ATB 2 is approximately 149 acres, with direct runoff to ATB 2 from approximately 47 acres with the remaining 102 acres being from ATB 1, CPP and SP discharges.*

Table 4 below identifies various existing and proposed elevation conditions related to the hydrologic analysis of Ash Treatment Basin #2 that were summarized in the MACTEC report.

**Table 4. 2010 Ash Treatment Basin #2 Elevation Conditions**

Elevation Condition	Elevation*
Ash Treatment Basin #2, 100-yr, 48-hr Flood Elevation (ft)	399.27
Existing Dam Crest Minimum Elevation (ft)	398.94
Current Operating Water Surface Elevation (ft)	397.4**
Current Operating Freeboard (ft)	398.94 - 397.4 = 1.54
100-year (48-hour) Flood Elevation Freeboard (ft)	-0.33

\*Elevations based the 2010 hydrographic survey.

\*\*MACTEC report stated the weir is normally set with a crest elevation of 397.4 ft.

According to the MACTEC report, the Ash Treatment Basin #2 would experience an overtopping event at the low point of the dam crest with an approximate 25-year, 24-hour event with the 10-year, 24-hour event the freeboard is estimated to be 0.07 feet when starting at normal pond water level (397.4 ft). MACTEC's report stated that the 100-year, 48-hour duration storm was determined to be the critical storm event. Based on an existing minimum dam crest elevation of 398.94, the water surface elevation for this event is calculated to be 399.27 thereby reflecting in an overtopping event (freeboard = -0.33 ft). MACTEC recommends the following

modifications to provide a suitable hydrologic condition for the unregulated (as a dam) Ash Treatment Basin #2:

- *Remove two 6-inch stop-logs to lower the normal water level 1.0 ft to 396.4 ft (weir crest elevation);*
- *Construct an emergency spillway with an overflow crest elevation of 399.0 ft. (spillway crest length of 50 ft, but crest length could be modified with discussed below by a design analysis); and*
- *Raise the embankment crest minimum crest elevation to 400.0 ft to provide a minimum freeboard of 6 inches for the 100-year event. The amount of dam, emergency spillway width, and desired freeboard are inter-related and further engineering investigation would be required to determine to optimum approach. As identified previously, a 1.0 ft freeboard would be more desirable, but a 0.5 ft freeboard may be acceptable if the embankment is sufficiently wide, uniform, has a good grass cover, littoral vegetation to dissipate wind-generated waves is present along the shoreline, and the embankment meets other desirable characteristics that would minimize erosion potential.*

According to the MACTEC report, the Kentucky Department of Natural Resources and Environmental Protection, Division of Water (KDEP-DOW) has not classified Ash Treatment Basin #2; therefore, dam permits have not been issued for this dam.

### Finishing Pond #3

No hydrologic or hydraulic design criteria or calculations were provided for the Finishing Pond #3.

### Scrubber Pond

According to the MACTEC report, the characteristics for the Scrubber Pond are as follows:

*Discharge from the SP is by pumping to ATB 2. A manually operated duplex pump system pumps at a rate 350 gallons per minute (gpm). . . A natural upland drainage area of approximately 6-7 acres would drain to the SP but runoff is intercepted by two diversion ditches, one draining to the east and the other draining to the west. The capacity and efficiency of the diversions are not accurately known. The ditches are apparent on the topographic mapping, but there is insufficient detail to reliably estimate the flow capacity. A culvert appears to exist under the access road to the dam crest but is not specifically identified on the topographic mapping and type and size are not known. It was assumed that for the existing condition the ditches can convey a total of 10 cfs around the SP (discharging into ATB 3) and any runoff from the upstream contributing 7-acres drainage area in excess of 10 cfs would flow into the SP. No inflows were assumed to the SP other than precipitation runoff.*

During AMEC's site visit performed on August 16, 2010, no drainage ditches were observed to be discharging into the Scrubber Pond.

Table 5 below identifies various existing and proposed elevation conditions related to the hydrologic analysis of Scrubber Pond that were summarized in the MACTEC report.

**Table 5. 2010 Scrubber Pond Elevation Conditions**

Elevation Condition	Elevation
Scrubber Pond, 100-yr, 48-hr Flood Elevation (ft)	403.17
Existing Dam Crest Minimum Elevation (ft)	403.77
Current Operating Water Surface Elevation (ft)	402.5
Current Operating Freeboard (ft)	403.77 - 402.5 = 1.27
100-year (48-hour) Flood Elevation Freeboard (ft)	0.60

According to the MACTEC report, a dam permit has been issued for the Scrubber Pond by the Kentucky Department of Natural Resources and Environmental Protection, Division of Water (KDEP-DOW). The dam has been classified as a Class A Low Hazard Dam. Permitted structures in Kentucky (Water Resources Memo No. 5, Section F.I.A.) require that an emergency spillway be constructed and that the capacity of the emergency spillway will in no case be less than 200 cubic feet per second (cfs). MACTEC's report stated that, although the Scrubber Pond is a permitted structure, the criteria outlined in Memo 5 appeared to be inappropriate and excessive for the structure. KDEP-DOW acknowledged this exception in a letter dated October 2, 1975 that states the absence of an emergency spillway is acceptable for the Scrubber Pond provided that the principal spillway and storage capacity are such that the required freeboard is met for the freeboard design hydrograph.

MACTEC reports the results for the Scrubber Pond indicate marginally sufficient capacity, with the 100-year (48-hour) principal spillway design flood having a calculated freeboard equal to 0.6 ft. MACTEC recommends the following modifications to provide a suitable hydrologic condition for the regulated (as a dam) Scrubber Pond:

- Lower the normal operating water level from 402.5 to 402.0 ft; and
- Install an emergency spillway with crest elevation of 402.5 ft (small outlet similar in capacity to an 18-inch diameter culvert or a riprap chute; variance or exception required from DNREP-DOW).

Coal Pile Runoff Pond

According to the MACTEC report, the characteristics for the Coal Pile Runoff Pond are as follows:

*The CPP discharge to ATB 2 is through an 18-inch corrugated metal pipe (CMP). The 40-ft long culvert has an upstream flow-line (FL) elevation of 400.8 ft and an outlet FL elevation of 400.2 ft. The earthen embankment has a crest elevation near the culvert of approximately 406 ft, based on available topographic mapping (FMSM Engineers, Existing Conditions and Baseline Layout, Ash Treatment Basin No. 4, Sheet 4 of 51, February 1998) the low point of the earthen embankment is between 404 ft and 406 ft. Based on the configurations of the elevation contour lines, it was estimated that the minimum embankment elevation is approximately 405 ft near the southern end of the dam segment that separates the CPP from ATB 2. There is no identified emergency spillway. There are no inflows to the CPP other than precipitation runoff from the approximately 14.4 acres of drainage area to the CPP.*

Table 6 below identifies various existing and proposed elevation conditions related to the hydrologic analysis of Coal Pile Runoff Pond that were summarized in the MACTEC report.

**Table 6. 2010 Coal Pile Runoff Pond Elevation Conditions**

Elevation Condition	Elevation
Coal Pile Runoff, 100-yr, 48-hr Flood Elevation (ft)	402.83
Existing Dam Crest Minimum Elevation (ft)	405.0
Current Operating Water Surface Elevation (ft)	401.8
Current Operating Freeboard (ft)	405.0 - 401.8 = 3.2
100-year (48-hour) Flood Elevation Freeboard (ft)	2.17

MACTEC reports the results indicate the Coal Pile Runoff Pond has a freeboard of 2.4 ft, 2.2 ft, and 1.7 ft for the 100-year, 24-hour event, 100-year, 48-hour event, and 24-hour Kentucky freeboard design storm, respectively based on a normal pond elevation of 401.8 ft. MACTEC's reports states that the Coal Pile Runoff Pond spillway would appear to be adequate in terms of hydrologic performance and potentially appropriate design criteria.

**3.2.2 2011 Addendum to the 2010 Hydrologic and Hydraulic Study**

Addendum A to the August 12, 2010 report entitled Assessment of Spillway Hydrologic Adequacy for the Coal Pile Pond, Ash Treatment Basin No. 2, and Scrubber Pond at Green River Generating Station (described previously in Section 3.2.1.) was completed by MACTEC and dated January 25, 2011. Addendum A was included with the KU comments to the September 2010 Draft Report. The purpose of the Addendum was to provide information concerning updated topographic mapping, field survey of selected impoundment storage areas and facility modifications, as well as present the effects of these changes to the design storm freeboard in the ponds.

Analyses were completed using HEC-HMS version 3.5. Elevation/area relationships for each impoundment were updated based on the new topographic information. Elevation/discharge curves for ATB 1 and ATB 2 were also provided. These curves were used in calculation of existing condition values. The report noted that the existing conditions model produced "freeboard amounts that varied from the earlier analysis [2010], with some increasing and some decreasing." The Freeboard Design Flood Hydrograph (equation (4) of KDOW EM No. 5), calculated utilizing the 100-year, 24-hour precipitation value for Muhlenburg County, results in a rainfall depth of 10.22 inches for use in model applications.

Ash Treatment Basin #1

Addendum A reported that no changes were made to the crest or operating water surface elevations or the operation of the impoundment. Revised elevations, due to updated topographic mapping information, are presented in Table 7.

**Table 7. 2011 Ash Treatment Basin #1 Elevation Existing Conditions**

Elevation Condition	Elevation
100-yr, 48-hr Flood Elevation (ft)	447.54
100-yr 24-hr Freeboard Hydrograph Design Flood Elevation (ft)	448.04
Existing Dam Crest Minimum Elevation (ft)	449.40
Current Operating Water Surface Elevation (ft)	445.9
Current Operating Freeboard (ft)	449.40 - 445.9 = 3.5
100-yr 48-hr Flood Freeboard (ft)	449.40 - 447.54 = 1.86
100-yr 24-hr Freeboard Hydrograph Design Flood Freeboard (ft)	449.40 - 448.04 = 1.36

The 100-Year, 48-Hour flood elevation freeboard for ATB 1 decreased from 2.11 feet to 1.86 feet. Although unreported in the 2010 study, the 100-year 24-hour Freeboard Hydrograph Design Flood Freeboard was reported to be 1.36 feet. The KDOW Freeboard Design Hydrograph calculation results in rainfall values that are less than would result from the ½ PMF event that is recommended by MSHA for dam freeboard design for dams that are assigned a Significant Hazard Potential. Additionally, the MSHA guidelines recommend that a minimum of 3 feet of freeboard exist between the design storm maximum water surface elevation and the dam crest.

Ash Treatment Basin #2

Addendum A reported that low portions of the crest have been raised to elevation 400.0 ft (NAVD88) from the low elevation of 398.94 ft. (NAVD88) that was identified in the 2010 report. Also, Addendum A noted that “the normal water level (initial water level in model) in ATB 2 was lowered slightly based on updated information,” from 397.4 feet to 397.0 feet. Updated freeboard values are identified in Table 8.

**Table 8. 2011 Ash Treatment Basin #2 Existing Elevation Conditions**

Elevation Condition	Elevation*
100-yr, 48-hr Flood Elevation (ft)	400.14
100-yr 24-hr Freeboard Hydrograph Design Flood Elevation (ft)	400.26
Existing Dam Crest Minimum Elevation (ft)	400.0
Current Operating Water Surface Elevation (ft)	397.0
Current Operating Freeboard (ft)	400.0 - 397.0 = 3.0
100-year 48-hr Flood Freeboard (ft)	400.0 - 400.14 = -0.14
100-yr 24-hr Freeboard Hydrograph Design Flood Freeboard (ft)	400.0 - 400.26 = -0.26

The 100-Year, 48-Hour flood elevation freeboard for ATB 2 increased from -0.33 feet, as reported in the 2010 Study, to -0.14 feet as a result of the reduction in operating water surface elevation coupled with the increase in dam crest elevation, as well as updated topographic mapping information. However, the 100-Year, 48-Hour flood elevation data indicates that the rise in water surface elevation from runoff increased from 1.87 feet in the 2010 Study to 3.14 feet in the 2011 Study. The previously unreported Freeboard Design Hydrograph rainfall event

(100-Year, 24-Hour used here), which is less than the ½ PMF event that is recommended by MSHA for freeboard design of dams that carry a Significant Hazard Potential, overtopped the crest by 0.26 feet (-0.26 feet freeboard).

As a result of the negative freeboard calculations, the Addendum described two potential measures to bring ATB 2 into compliance with KDOW standards. The focus of Alternative 1 was to increase the dam crest elevation “to prevent overtopping by the Freeboard Design Flood.” Alternative 2 aimed to maintain the existing dam crest elevation while adding an emergency spillway. The Addendum noted that “the emergency spillway was assumed to be a 40-foot wide spillway that 1) does not flow for events more frequent than a 10-year event and 2) prevents the Freeboard Design Flood from overtopping the embankment.” MACTEC also noted that other combinations of increasing crest elevation, emergency spillway addition, and decreasing operating water surface elevations were possible. Table 9 illustrates reported model results for Alternatives 1 and 2.

**Table 9. 2011 Alternatives 1 and 2 Ash Treatment Basin #2 Elevation Conditions**

Elevation Condition	Elevation*
Operating Water Surface Elevation (ft)	397.0
<b>Alternative 1</b> (increased crest elevation)	
100-yr 24-hr Freeboard Design Hydrograph Flood Elevation (ft)	402.56
Proposed Dam Crest Elevation (ft)	402.6
100-yr 24-hr Freeboard Design Hydrograph Freeboard (ft)	402.6 - 402.56 = 0.04
<b>Alternative 2</b> (addition of 40 ft. emergency spillway)	
10-year 48-hr Flood Water Surface Elevation* (ft)	399.22
100-yr 24-hr Freeboard Design Hydrograph Flood Elevation (ft)	399.56
Proposed Dam Crest Elevation	400.00
100-yr 24-hr Freeboard Design Hydrograph Freeboard (ft)	400.00 - 399.56 = 0.44

\*Emergency spillway elevation set at 10-year, 48-hour flood water surface elevation

The Addendum noted that evaluation of Alternative 1 indicated that the dam crest would need to be increased to an elevation of approximately 402.6 feet (NAVD88) to avoid overtopping the dam crest (freeboard equal to 0.04 feet) following the Freeboard Design rainfall event. The operating water surface was reported to be identical to that of the existing condition at 397.0 feet. Although the provided elevation/area curve for existing conditions presented data extrapolated to elevation 404.0 for ATB2, the reported Alternative 1, 100-Year, 24-Hour Freeboard Design Hydrograph Flood Elevation of 402.56 was not substantiated by that curve.

Addition of a 40-foot emergency spillway, per Alternative 2, placed at the 10-year, 48-hour rainfall event water surface elevation of 399.22 feet (NAVD88), would result in the successful passage of the Freeboard Design Hydrograph while maintaining a freeboard of 0.44 feet.

Each alternative investigated by MACTEC has merit, however, the KDOW Freeboard Design Hydrograph calculations result in precipitation values that are less than those that would result from the ½ PMF event as recommended by MSHA for a dam with a Significant Hazard

Potential. Additionally, the MSHA guidelines recommend that a minimum of 3 feet of freeboard exist between the design storm maximum water surface elevation and the dam crest. It is AMEC's opinion that freeboard depths of 0.04 and 0.44 feet above potentially less than adequate design flood elevations do not provide adequate impoundment protection against an appropriate design storm.

Scrubber Pond

Addendum A reported that two, automatically operated 200 gallon per minute (gpm) discharge pumps were installed to replace two smaller (350 gpm), manually operated pumps. Additionally, it was reported that "the pumps controls are set to maintain a water level of approximately 401.0 ft NAVD 1988, or approximately 3.0 ft below the dam crest elevation." The reported new operating water surface elevation is 1.5 feet lower than that elevation reported previously in MACTEC's 2010 Hydrologic and Hydraulic Analysis. The lead pump was designed to be activated at a water surface elevation of 401.2 ft, while a water surface elevation of 401.5 ft would signal the second pump to operate. Results of the hydrologic and hydraulic modeling for the Scrubber Pond are presented in Table 10.

**Table 10. 2011 Scrubber Pond Elevation Existing Conditions**

Elevation Condition	Elevation
100-yr, 48-hr Flood Water Surface Elevation (ft)	402.00
100-yr, 24-hr Freeboard Design Hydrograph Flood Elevation (ft)	402.19
Existing Dam Crest Minimum Elevation (ft)	403.77
Current Operating Water Surface Elevation (ft)	401.0
Current Operating Freeboard (ft)	403.77 - 401.0 = 2.77
100-yr 48-hr Flood Freeboard (ft)	403.77 - 402.00 = 1.77
100-yr, 24-hr Freeboard Design Hydrograph Flood Freeboard (ft)	403.77 - 402.19 = 1.58

As a result of updated topographic mapping information as well as installation of higher capacity pumps and a 1.5 foot reduction of the operating water surface elevation, the 100-Year, 48-Hour flood freeboard for the Scrubber Pond increased from 0.6 feet to 1.77 feet, while the 100-Year, 24-Hour Freeboard Design Hydrograph resulted in a freeboard value of 1.58 feet.

The KDOW Freeboard Design Hydrograph calculations result in precipitation values that are less than those that would result from the ½ PMF event as recommended by MSHA for a dam with a Significant Hazard Potential. Additionally, the MSHA guidelines recommend that a minimum of 3 feet of freeboard exist between the design storm maximum water surface elevation and the dam crest.

Coal Pile Runoff Pond

Addendum A reported that the low portions of the Coal Pile Pond dam crest were increased to elevation 405.5 ft (NAVD88). The 2011 reported operating water surface elevation remained unchanged at elevation 401.8 ft (NAVD88). Table 11 presents results of the hydrologic and hydraulic modeling that resulted from the updated topographic modeling, as well as the increased crest elevation.



**Table 11. 2011 Coal Pile Runoff Pond Elevation Existing Conditions**

Elevation Condition	Elevation
Coal Pile Runoff, 100-yr, 48-hr Flood Elevation (ft)	403.58
100-yr 24-hr Freeboard Hydrograph Design Flood Elevation (ft)	404.08
Existing Dam Crest Minimum Elevation (ft)	405.5*
Current Operating Water Surface Elevation (ft)	401.8
Current Operating Freeboard (ft)	405.5 - 401.8 = 3.7
100-year (48-hour) Flood Elevation Freeboard (ft)	405.5 - 403.58 = 1.92**
100-year 24-hour Freeboard Design Flood Freeboard (ft)	405.5 - 404.08 = 1.42**

\*Reported erroneously as 405.0 feet in MACTEC results Table A-1. Summary of Selected HEC-HMS Results for 2011 Existing Conditions; however, the 2011 Summary text correctly reports the elevation as 405.5 feet.

\*\*MACTEC reported values were 0.5 feet below those reported by AMEC in Table 11. AMEC adjusted/increased MACTEC's reported maximum water surface elevations by 0.5 feet to correct the error.

The 100-Year, 48-Hour flood elevation freeboard for the Coal Pile Pond decreased from 2.17 feet to 1.92 feet. The (AMEC adjusted) 100-year 24-hour Freeboard Hydrograph Design Flood Freeboard was 1.42 feet. The KDOW Freeboard Design Hydrograph calculation results in rainfall values that are less than would result from the ½ PMF event that is recommended by MSHA for dam freeboard design for dams that have a Significant Hazard Potential. Additionally, the MSHA guidelines recommend that a minimum of 3 feet of freeboard exist between the design storm maximum water surface elevation and the dam crest.

### 3.3 Structural Adequacy and Stability

The Commonwealth of Kentucky Department of Natural Resources Environmental Protection, Bureau of Environmental Protection, Division of Water, dated June 1, 1980 provides guidelines for the geotechnical investigation and analysis of existing earth dams. The guidelines were written pursuant to the provisions set forth in KRS 151.125(2). Earthen dams, when analyzed using the methods, guidelines, and procedures of the agencies listed in the guidelines to determine safety factors, can be considered to have acceptable stability if the analyses yield at least the minimum safety factors shown in Table 12.

Two well known sources for embankment design and evaluation criteria include The United States Army Corps of Engineers (USACE) and the United States Mine Safety and Health Administration (MHSA). Minimum recommended factors of safety for different loading conditions can be found in those agency publications, as shown in Table 12 below.

**Table 12. Minimum Recommended Dam Safety Factors**

LOAD CASE	KDOW <sup>1</sup>	MSHA CRITERIA <sup>2</sup>	USACE <sup>3</sup>
Rapid Drawdown	1.2	1.3	1.1 <sup>4</sup> -1.3 <sup>5</sup>
Long-Term Steady State Seepage	1.5	1.5	1.5
Earthquake Loading	1.0	1.2	--- <sup>6</sup>

<sup>1</sup> Guidelines for the Geotechnical Investigation and Analysis of Existing Earth Dams, 1980, Kentucky Division of Water

<sup>2</sup> Coal Mine Impoundment Inspection and Plan Review Handbook, 2007, US Mine Safety and Health Administration

<sup>3</sup> Slope Stability Publication, EM1110-2-1902, 2003, US Army Corps of Engineers, Table 3-1: New Earth and Rock-Fill Dams

<sup>4</sup> Applies to drawdown from maximum surcharge pool

<sup>5</sup> Applies to drawdown from maximum storage pool

<sup>6</sup> Referred to USACE Engineer Circular "Dynamic Analysis of Embankment Dams" document that is still in preparation

AMEC reviewed the July 14, 2010 report entitled *Final Geotechnical Report, Main Ash Pond, Slope Stability Analysis and Repair, Kentucky Utilities, Green River Station* prepared by Associated Engineers, Inc. and the September 3, 2010 report entitled *Geotechnical Exploration and Slope Stability Analysis Data Package, Kentucky Utilities (KU), Green River Power Station, Number 2 Pond & Scrubber Pond, South Carrollton, Muhlenburg County, Kentucky* prepared by MACTEC Engineering and Consulting, Inc. The recently completed stability analyses are summarized in Section 3.3.1 and 3.3.2. MACTEC included the Coal Pile Runoff Pond into their analysis for Ash Treatment Basin #2. To analyze the structural adequacy and stability of the Ash Treatment Basin #1 (Main Ash Pond), Ash Treatment Basin #2, Scrubber Pond, and Coal Pile Runoff Pond at Green River Generating Station, AMEC reviewed the material provided by Kentucky Utilities with respect to the load cases shown in Table 12. Factors of safety documented in the provided material were compared with those factors outlined in the table to help determine whether the impoundments meet the requirements for acceptable stability.

**3.3.1 Ash Treatment Basin #1 - July 2010 Structural Adequacy and Stability**

Associated Engineers, Inc. recently (July 2010) completed the report entitled *Final Geotechnical Report Main Ash Pond Slope Stability Analysis and Repair*, for the Green River Station. According to Associated Engineers, the report presents "the results of investigations including boring logs, laboratory data, description of subsurface conditions and stability analysis." Additionally, the report includes "repair recommendations and an inspection summary specific to a slope failure which was corrected during May and June of 2010."

Field and Subsurface Investigation

Visual inspection of the slope failure area and toe of the dam was performed as part of the initial site reconnaissance. A buttress was noted to have "been constructed on the downstream slope of the dam beginning approximately 200 feet northeast of piezometer 3A." It was noted that the buttress was "not shown on the original H. C. Nutting drawings". Additionally, although "no other records could be located....it is known to have been constructed to repair a previous slope failure."

The subsurface investigation included in the report was undertaken to "determine the extent of the slope failure and provide strength parameters for stability analysis." Drilling operations began in late December 2009, using a rotary drill rig and hollow stem augers per ASTM D-1452. Representative soil samples were collected by "split barrel (Standard Penetration Test)

sampling procedure” per ASTM D-1586. Procedures outlined in ASTM D-1587 were used to collect representative undisturbed samples using 3-inch diameter Shelby tubes. Associated Engineers noted that “In some cases, soil compaction was such that the tube could not penetrate the material sufficiently to obtain adequate recovery for testing.” Figure 9 illustrates boring locations, stability cross sections, and piezometer locations for this study.

Laboratory Testing

Soil analyses performed on representative samples included moisture content, sieve analysis, Atterberg limits, unit weight, and consolidated-undrained (CU) triaxial compression tests that included both total and effective stress analysis. The Associated Engineers’ report stated that “Triaxial testing for stability analysis included samples from P1, P2, and P3.” Associated Engineers noted that they were unable to collect sufficient undisturbed fly ash samples; therefore, they conservatively estimated strength parameters based on “N-values, experience with similar materials, and published data.” Table 13 below summarizes soil data used in the stability analyses.

**Table 13. July 2010 Stability Analysis Soil Parameters - Ash Treatment Basin #1**

Soil Layer Elevation (ft)	Soil Description	Saturated Unit Weight (pcf)	Effective Cohesion, C (psf)	Friction Angle, $\Phi$ (degrees)
“Back In” Slope Failure				
450 - 425	Sandy lean clay	130.0	195.0	33.6
425 - 405	Sandy lean clay	130.0	250.0	28.0
405 - 402	Sandy lean clay-old fill	110.0	0	26.0
402 - 393	Fly ash and clay	133.0	359.0	30.2
393 - 385	Silty clay with shale fragments	138.0	0	22.0
	Bedrock			
Critical Slope				
450 - 433	Sandy lean clay/lean clay with sand	133.8	174	26.4
433 - 410	Sandy lean clay/lean clay with sand	138.2	258	28.1
410 - 390	Silty clay/ sandy lean clay/lean clay with sand	131.8	565	23.8
390 - 385	Silty clay	130.2	195	33.6
	Bedrock			

Slope Failure Area Stability

Discussion of slope stability analyses were presented for the slope failure area using the cross section A-A’ as shown on Figure 10. The REAME2008 computer program that utilizes rotational equilibrium methodology was used in the analyses. Associated Engineers also noted that the

seismic safety factor that was used “is based on the pseudo-static method using a seismic coefficient.”

The report noted that the failure area cross section A-A’ was first analyzed for stability using strength data that had been obtained from testing. Long-term, steady state seepage and earthquake loading analyses resulted in factors of safety equal to “1.53 and 1.25”, respectively. Associated Engineers noted that these favorable results indicated that the “overall configuration of the dam is stable.” As a result, rapid drawdown analysis was “deemed to be unnecessary since backfilling with CCB has occurred to within 12 feet of the tip of the dam on the upstream side.”

Following the initial analyses, Associated Engineers evaluated the failure area stability using a “back in” approach. The soil strength parameters required to yield a safety factor of 1.0 (imminent failure), as well as a slip surface that closely reflected the actual failure surface, were determined. The resulting soil strength angle, phi, and cohesion for material above the original ground surface, C, were found to be equal to 22 degrees and zero (0) pounds per square foot. Associated Engineers noted that these results indicate that the stability model is conservative “since higher strength values were obtained from the interior of the dam.”

Associated Engineers noted that numerous design options were evaluated to correct the failure area on Ash Treatment Basin #1 (Main Ash Pond) embankment, with the chosen design as described previously in Section 1.4.2 of this Draft Assessment Report. Stability analyses performed at cross section A-A’ for the repaired area, resulted in calculated factors of safety as shown in Table 14.

**Table 14. July 2010 Factors of Safety for Ash Treatment Basin #1 Slope Failure Area**

Analysis	Factors of Safety	
	Long Term	Earthquake Loading
Required Minimum Safety Factor	1.5	1.0
Existing Condition (Pre-failure)	1.51	1.22
“Back In” Analysis	0.94	--
25 ft. Rock Bench/Berm Slide Repair	1.55	1.23

Associated Engineers noted that factors of safety that resulted from the stability analyses are greater than the minimum values required by KDOW; therefore, in their opinion, the stability of the dam at the repair location should be considered acceptable.

Global Dam Stability

Associated Engineers evaluated the overall stability of the dam by reviewing cross sections and drilling data contained within a report completed in July 2010 by H. C. Nutting, as well as by analyzing a chosen critical cross section labeled B-B’, as shown on Figure 11. The dam at cross section B-B’ was noted to have a maximum height (from crest to downstream toe), and to contain close to a maximum thickness of fill material (measured from the top of the dam vertically downward). Cross section B-B’ was also chosen for stability evaluation because, Associated Engineers noted, it “does not overlie a stabilizing drainage layer based on the H. C. Nutting data (cross sections 9+50 to 10+00).” AMEC reviewed the H.C. Nutting design data and Sheet 4 (of 29) of the drawings, dated revised May 1976, indicates drainage layers were

constructed on the south embankment at three locations: +/- Station 7+25 to +/- Station 9+25, +/- Station 11+25 to +/- Station 12+90, and +/- Station 17+75 to +/- Station 19+25.

Dam fill material was modeled based on strength data from soil collected from all drilling locations. The report noted that the “worst case” condition used values from boring P2 because these values were noted to collectively represent the lowest soil strengths obtained across the dam for fill construction. The soil interval below the original ground surface was represented using soil data from borings P2 and P3. Associated Engineers noted that with respect to triaxial strength data that “values from P3 were representative of an upper interval directly below the ground surface variably consisting of lean clays and silty clays”; additionally, a “lower unit of silty clay occurring down to refusal exhibited significantly higher SPT values and was modeled using triaxial data from P2.” With respect to the water surface model input, Associated Engineers noted that the “phreatic surface was modeled from the ground surface at the toe of the dam extending directly to the highest recorded depth in piezometer P2.”

Calculated factors of safety for the critical cross section B-B’ are shown in Table 15.

**Table 15. July 2010 Factors of Safety for Ash Treatment Basin #1 at Critical Section**

Analysis	Factors of Safety	
	Long Term	Earthquake Loading
Required Minimum Safety Factor	1.5	1.0
Existing Condition	1.64	1.30

Minimum factors of safety, per KDOW, were again included in the table by Associated Engineers for comparative purposes. Factors of safety for the critical section were determined to be greater than KDOW specified minimums, therefore the structural integrity of the dam was considered to be satisfactory.

**3.3.2 Ash Treatment Basin #2 and Scrubber Pond - September 2010 Structural Adequacy and Stability**

MACTEC Engineering and Consulting, Inc. (MACTEC) completed a report entitled *Geotechnical Exploration and Slope Stability Analysis Data Package, Kentucky Utilities Green River Power Station, Number 2 Pond & Scrubber Pond*, dated September 3, 2010. The report presented a summary of guidance documents and data that were reviewed, the geotechnical exploration that was performed to obtain additional data for use in evaluation of the ponds’ structural stability, as well as the results of the structural stability analyses that were completed for two cross sections from each pond. It was noted that the study was not complete and a final report with analyses for a total of five cross sections from each pond will be submitted later.

Subsurface data was collected from five “critical” cross sections for each pond. “Critical” slopes were chosen “based on topography and nature of the exposed slope.” Ten soil test borings were drilled along the pond crests and thirteen soil test borings were drilled along the toe of the embankments, with each boring being advanced up to 40 feet. Three piezometers were installed along each pond’s embankment crest to enable monitoring of piezometric levels within each embankment.

Soil classification tests included Atterberg limits, grain-size analyses, specific gravity, and unit weight determinations. Strength tests included consolidated undrained triaxial shear tests with

pore pressure monitoring to determine both total stress and effective stress parameters. MACTEC noted that strength tests for this site are ongoing and that test results would be provided with their final report of geotechnical exploration and slope stability analyses. Statistical analysis was reportedly used with results from the Standard Penetration Test “to delineate subsurface conditions and estimate anticipated soil properties based on correlations and published data.”

Purdue University’s computer program PCSTABL was used to conduct slope stability analyses. MACTEC noted that “The program uses a two-dimensional limit equilibrium method of analysis and calculates the factor of safety based on the Modified Bishop Method of Slices.” MACTEC analyzed the embankments using steady state/maximum flooding conditions, rapid drawdown, and seismic conditions. Analyses results for the two completed sections, cross section 4 (Ash Treatment Basin #2) and 7 (Scrubber Pond) were included in the report. Cross section locations are as shown on Figure 12.

Bathymetric pond surveys and various topographic maps were utilized to determine site geometry for the analyses. Hand-held GPS units were reported used to estimate boring and cross section locations. The final report will contain a topographic survey of the cross sections.

MACTEC reported that generally “the dikes were constructed of sandy clay fill reportedly excavated from the incised portion of the ponds.” Alluvial soils that exist beneath the placed fill were found to be comprised of silty to sandy, lean clay. Table 16 summarizes the soil parameters that were selected for the slope stability analyses for both the Ash Treatment Basin #2 and Scrubber Ponds. Soil parameters were chosen “based on various resources including the results of the extensive laboratory testing described above, field testing and observations, published information on similar soil types and our experience.”

**Table 16. September 2010 MACTEC Soil Parameters for Ash Treatment Basin #2 and Scrubber Pond**

Soil Type No.	Soil Description	Unit Weight		Effective Stress	
		Total (pcf)	Saturated (pcf)	Cohesion C' (psf)	Friction Angle $\Phi'$ (degrees)
<b>Ash Treatment Basin #2</b>					
1	CL fill	128	133	20	34
2	CL alluvium	120	125	0	34
3	CL alluvium	127	132	6	32
4	CCW	90	95	0	30
<b>Scrubber Pond</b>					
1	CL fill	121	126	60	30
2	CL alluvium	120	125	0	33
3	CL alluvium	118	123	0	28
4	CCW	90	95	0	30

Using published guidance for the site location, MACTEC reported that seismic conditions for the site were reported as modeled under dynamic loading conditions using a peak ground acceleration value of 0.150g, for horizontal and vertical movement, for a two percent probability of exceedence in 50 years.

MACTEC noted that the “maximum operating pool was conservatively modeled as the crest elevation for each pond.” Crest piezometer water level readings were used and modeled to extend across the pond through the embankments to simulate a “worst case” condition. The amount of CCW in the pond was estimated using the results of the bathymetric survey completed by MACTEC.

Results of the stability analyses performed for Cross Sections 4 (Number 2 Pond) and 7 (Scrubber Pond) are shown in Table 17. Slopes that were used for each section model are included in the Table.

**Table 17. September 2010 Slope Stability Analyses Results for Ash Treatment Basin #2 and Scrubber Pond**

Critical Section	Upstream Slope (H:V)	Downstream Slope (H:V)	Long Term Steady State/Max Surcharge Pool		Rapid Drawdown		Seismic	
			Target FOS*	FOS	Target FOS*	FOS	Target FOS*	FOS
Number 2 Pond								
Cross Section 4 (Upstream)	3.0:1.0	--	1.5/1.4	2.9	1.2	1.5	1.2	1.4
Cross Section 4 (Downstream)	--	2.0:1.0	1.5/1.4	1.6	1.2	1.6	1.2	1.2
Scrubber Pond								
Cross Section 7 (Upstream)	2.2:1.0	--	1.5/1.4	2.5	1.2	1.2	1.2	1.4
Cross Section 7 (Downstream)	--	3.2:1.0	1.5/1.4	2.3	1.2	2.3	1.2	1.3

Target Factor of Safety References: (1) Design Criteria for Dams & Associated Structures (401 USACE EM 1110-2-1902: Slope Stability, (3) MSHA Engineering and Design Manual. KAR 4:030, KAR 4:040), (2)

MACTEC noted that the analyses, performed using the parameters and geometry described, indicated that the cross sections analyzed to this point provide factors of safety that meet or exceed the published factors of safety for the cases analyzed.

**3.3.3 Finishing Pond #3 - Structural Adequacy & Stability**

Stability analyses were not provided for this structure.

**3.3.4 Coal Pile Runoff/Ash Treatment Basin #2 and Scrubber Pond - December 2010 and January 2011 Structural Adequacy & Stability**

Subsequent to AMEC’s submittal of the *Dam Safety Assessment Draft Report*, dated September 2010, AMEC received the December 3, 2010 report entitled *Report of Geotechnical Exploration and Slope Stability Analyses Kentucky Utilities (KU) Green River Power Station, No. 2 Pond/Coal Pile Runoff Pond and Scrubber Pond, South Carrollton, Muhlenberg County, Kentucky* prepared by MACTEC Engineering and Consulting, Inc. and their *Addendum A to that report*, dated January 24, 2011. MACTEC performed a total of 10 cross-sections, 5 cross-sections along the Coal Pile Runoff/Ash Treatment Basin #2, The report presented a summary of guidance documents and data that were reviewed, the geotechnical exploration that was performed to obtain additional data for use in evaluation of the ponds’ structural stability, as well as the results of the structural stability analyses that were completed for a total of ten cross

sections. Five cross sections each were presented for the Coal Pile Runoff/Ash Treatment Basin #2 as well as the Scrubber Pond.

Subsurface data was collected from ten "critical" cross sections for the No 2, Coal Pile Runoff and Scrubber ponds. "Critical" slopes were chosen "based on topography and nature of the exposed slope." Two borings were drilled at each of 10 cross-sections (one crest boring and one downstream toe boring per cross-section). Ten soil test borings were drilled along the pond crests and thirteen soil test borings were drilled along the toe of the embankments, with each boring being advanced up to 40 feet. The report notes the "three additional toe borings were drilled to further explore unanticipated conditions encountered at Section 2." Three piezometers were installed along each pond's embankment crest to enable monitoring of piezometric levels within each embankment.

Soil classification tests included Atterberg limits, grain-size analyses, specific gravity, and unit weight determinations. Strength tests included consolidated, undrained, triaxial shear tests with pore pressure monitoring to determine both total stress and effective stress parameters. Statistical analysis was reportedly used with results from the Standard Penetration Test "to delineate subsurface conditions and estimate anticipated soil properties based on correlations and published data."

As outlined in their draft report, MACTEC continued the use of the Purdue University's computer program PCSTABL to perform slope modeling and stability analyses. MACTEC noted that "The program uses a two-dimensional limit equilibrium method of analysis and calculates the factor of safety based on the Modified Bishop Method of Slices." MACTEC analyzed the embankments using steady state/maximum flooding conditions, rapid drawdown, and seismic conditions. Analyses results for the ten sections are summarized in Table 18. Cross section locations are as shown on Figure 12.

Bathymetric pond surveys and various topographic maps were utilized to determine site geometry for the analyses. Hand-held GPS units were reported used to estimate boring and cross section locations. The final report contains a topographic survey of the cross sections.

MACTEC's 3 September 2010 reported that generally "the dikes were constructed of sandy clay fill reportedly excavated from the incised portion of the ponds."; however, the 3 December 2010 sections 4.4 provides a more detailed descriptions of the soil conditions encountered and is described below:

*Surficial Materials. A surface layer of gravel was encountered in six crest borings (B-1C, B-3C through B-6C and B-10C). The gravel layer thickness ranged from about 1/2 foot to 1-1/2 feet. Surficial gravel was not encountered at other locations. The gravel consisted of well- to poorly graded crushed stone, with fine to coarse grained sand, and trace amounts of organics. Topsoil was encountered in two crest borings (B-8C and B-9C) and four toe borings (B-3T, B-4T, B-5T and B-7T). The topsoil thickness ranged from about 1/2 foot to 1 foot.*

*Stratum I - Lean Clay Fill. - Each of the borings encountered fill. The fill extended to depths ranging from approximately 9 to 23-1/2 feet in the crest borings and from 3 to 13 feet in the toe borings. The fill generally consisted of orange-brown, brown, and gray, silty and sandy, lean clay with trace amounts of black oxides, fly ash, gravel, and organics. The standard penetration test values (N-values) in the fill ranged from 3 to 19 blows per foot (bpf). Laboratory tests were performed on*



selected samples of the Stratum I fill soils. The natural moisture content of 55 Stratum I test samples ranged from 9 to 30 percent. Soil plasticity tests (Atterberg limits) performed on six samples indicated Liquid Limits of 30 to 48 and Plasticity Indices of 11 to 28. These values correspond to "CL" type soils, according to the Unified Soil Classification System (USCS). Grain size distribution tests performed on six samples indicated the samples consisted of approximately 0 to 1 percent gravel, 4 to 25 percent sand, and 74 to 96 percent silt and clay. Unit weight determinations performed on six Shelby tube samples indicated dry densities in the range of 96 to 143 pounds per cubic foot (pcf) and wet densities in the range of 120 to 167 pcf.

Stratum II - Coal Combustion Waste. Crest boring B-2C and toe borings B-1.5T, B-1.75T, B-2T and B-2.5T encountered ash underlying the Stratum I lean clay fill. The ash extended to a depth of 28 feet in Boring B-2C and 6 to 27 feet in the toe borings. This material consisted of light to dark gray, Coal Combustion Waste (CCW) consisting of fly ash and bottom ash with some sand and silt. The SPT N-values in this material ranged from 0 to 10 bpf. The natural moisture content of four fly ash samples ranged from 18 to 34 percent. The natural moisture content of five bottom ash samples ranged from 20 to 38 percent. Grain size distribution tests were performed on one fly ash sample and one bottom ash sample. These test results suggested USCS classifications of ML (silt) and SM (silty sand), respectively. Unit weight determinations on two Shelby tube samples indicated dry densities of 65 pcf (bottom ash) and 107 pcf (fly ash), with corresponding wet densities of 83 pcf and 136 pcf.

Stratum III - Lean Clay (Alluvium). The borings typically encountered lean clay alluvium beneath the Stratum I and Stratum II fill. This material extended to auger refusal on weathered shale in Borings B-1C, B-5C, and B-1.75T, and to boring termination at other locations. The alluvium typically consisted of gray, orange, and brown, silty lean clay with trace amounts of sand and weathered shale fragments. We visually classified an interval of alluvium in one boring (Boring B-10C) as silty sand (USCS CL-ML). The SPT N-values ranged from 0 to 21 bpf, indicating the consistency of this material ranged from very soft to very stiff.

The natural moisture content of Stratum III test samples ranged from 16 to 43 percent. Soil plasticity tests performed on seven samples indicated Liquid Limits of 27 to 40 and Plasticity Indices of 7 to 20. These values correspond to USCS "CL" type soils. Grain size distribution tests on seven samples indicated the samples consisted of approximately 3 to 24 percent sand and 76 to 97 percent silt and clay. Unit weight determination tests performed on four Shelby tube samples indicated dry densities in the range of 93 to 110 pcf and wet densities in the range of 118 to 129 pcf.

Consolidated-undrained (CU) triaxial shear test with pore pressure measurements were performed on five Shelby tube samples of Stratum III soils. The testing indicated total shear strength parameters ranging from about 130 to 1,800 pounds per square foot (psf) (cohesion,  $c$ ) and 7 to 30 degrees (angle of internal friction,  $\phi$ ), and effective shear strength parameters ranging from about 0 to 1,370 psf (cohesion,  $c'$ ) and 16 to 34 degrees (angle of internal friction,  $\phi'$ ).

Stratum IV - Weathered Shale. Gray to dark gray, highly weathered shale was encountered beneath Stratum III soils in three borings. The weathered shale extended to auger refusal depths of 11 and 27 feet in Borings B-1.75T and B-5C, respectively, and to the planned termination depth of about 40 feet in Boring B-1C. The SPT N-values in the weathered shale were 50 blows for 6 inches or less penetration. Based on the consistency of the recovered samples and the recorded penetration resistance values, we judged this material to be hard soil or very soft rock.

According to the December 2010 MACTEC, Inc. final report, “the soils parameters selected for slope stability analyses (see in Table 18 below) were chosen based on several resources, including laboratory testing performed for this exploration, our field testing and observations, published information on similar soil and material types, and our experience.” In addition, MACTEC states:

*For the purposes our analyses, we did not assign separate shear strength parameters for lean clay fill and alluvial lean clay. This is because the embankments were reportedly constructed using the on-site alluvial soil, which was assumed to have been excavated and placed using typical construction and compaction techniques. Therefore, for modeling purposes, the soil strata identified in Section 4 were categorized into layers based on consistency, as interpreted from the boring data. Additionally, based on our past experience with CCWs, rip rap, and published data, we assigned classification and strength test values for the CCW (both fly ash and bottom ash) and rip rap.*

*Technically, limestone rip rap such as that used to armor the downstream slope of Sections 2, 3, 7, and 8 does not exhibit any effective cohesion in laboratory testing. However, using an effective cohesion equal to zero for the rip rap at these sections causes two conflicts within the computer model:*

- 1. It indicates shallow sloughing critical circles; and*
- 2. It prevents the model from adequately analyzing deeper critical circles.*

*To overcome this shortcoming in the stability model, we assigned a nominal effective cohesion (100 psf) to the rip rap. This technique is typically used throughout the consulting industry and allows for more thorough elevations of the stability of each cross section analyzed.*

Using published guidance for the site location, MACTEC reported that seismic conditions for the site were reported as modeled under “dynamic loading conditions using a peak ground acceleration of 0.10g for 10 percent probability of exceedance in 50 years”. AMEC notes a peak ground acceleration value of 0.150g, for horizontal and vertical movement, for a two percent probability of exceedance in 50 years was used in the previous September 2010 analyses.

Results of the stability analyses performed for Cross Sections 1 through 10 are shown in Table 19. Slopes that were used for each section model are included in the table.

**Table 18. MACTEC Stability Analysis Soil Parameters - FINAL REPORT**

Soil Description	Unit Weight		Effective Stress Shear Strength	
	Moist (pcf)	Saturated (pcf)	Cohesion, c' (psf)	Internal Friction Angle, θ' (degrees)
CL (very soft, very soft/soft)	118	123	80	15
CL (soft, soft/firm)	122	127	100	16
CL (firm)	125	130	200	25
CL (firm/very stiff)	125	130	300	25
CL (stiff)	129	134	300	25
Weathered Shale	126	131	6	32
CCW - fly ash	90	95	0	20
CCW - bottom ash	108	113	0	28
Rip Rap	140	145	100	45

**Table 19. Slope Stability Analyses Results for Ash Treatment Basin #2 and Scrubber Pond -MACTEC REPORT -ADDENDUM A**

Target Section	Factors of Safety							
	Long-Term Steady State/Max Surcharge Pool		Long-Term Steady State/Max Surcharge Pool/Max Solids <sup>4</sup>		Rapid Drawdown		Earthquake Loading	
	US <sup>1</sup>	DS <sup>2</sup>	US <sup>1</sup>	DS <sup>2</sup>	US <sup>1</sup>	DS <sup>2</sup>	US <sup>1</sup>	DS <sup>2</sup>
<b>Coal Pile Runoff</b>								
Cross Section 1	4.1	1.4	n/a	1.4	4.1	1.6	2.0	1.0
<b>Ash Treatment Basin #2</b>								
Cross Section 2	6.7	2.3	n/a	n/a <sup>5</sup>	8.2	2.3	1.3 <sup>3</sup>	1.3
Cross Section 3	6.2	2.0	n/a	n/a <sup>5</sup>	7.8	2.0	1.3 <sup>3</sup>	1.3
Cross Section 4	3.6	2.4	n/a	2.4	1.9	2.4	1.0	1.5
Cross Section 5	2.5	2.0	n/a	2.0	1.5	2.0	0.8	1.2
<b>Scrubber Pond</b>								
Cross Section 6	5.1	2.5	n/a	2.4	3.2	2.5	2.2	1.8
Cross Section 7	3.6	1.9	n/a	1.9	2.7	1.9	1.5	1.2
Cross Section 8	6.0	1.6	n/a	1.6	3.6	1.6	1.9	1.2
Cross Section 9	3.5	2.3	n/a	2.3	2.4	1.4	1.8	1.6
Cross Section 10	6.1	1.7	n/a	1.7	3.6	1.7	3.3	1.2

<sup>1</sup>Upstream

<sup>2</sup>Downstream

<sup>3</sup>MACTEC notes: Shallow surface sloughing failure - top of ash at dam crest elevation at this cross-section

<sup>4</sup>includes CCW solids to upstream crest elevation; factor of safety against failure checked for downstream embankments face only

<sup>5</sup>Due to pond conditions at the time of the bathymetric survey (Associated Engineers, Inc., July 2010) upon which the models for Sections 2 and 3 were based, the long-term steady state/maximum surcharge pool analysis was performed at "pond full" conditions; therefore, a separate "pond full" or "maximum solids" analysis was not performed.

According to the MACTEC's final report, two cross-sections, cross-section 1 and cross-section 5, do not meet the minimum factors of safety as outlined by KEEC, USACE and MSHA of their report (see MACTEC's table 5). In discussion of these two cross-section, MACTEC states the following:

*"our (MACTEC) analyses, performed using the geometry and parameters described herein, indicate all slope sections meet or exceed the target minimum FS, except section 1 Downstream for steady-state/maximum surcharge pool conditions, and Section 5 Upstream for seismic conditions." MACTEC states "these slopes are currently stable under steady-state conditions and should not be expected to fail under normal operating conditions. However, some treatment may be required at Section 1 Downstream to increase the minimum FS under steady-state/maximum surcharge conditions, to meet the target FS. It is also important to note that although the analyses suggest the Section 5 Upstream slope has a minimum FS less than 1.0 under seismic loading conditions, which predicts failure of the slope under seismic loading, seismic loads would have to be imposed on the slope to induce the failure predicted by the analyses. The minimum FS under seismic loading is not an indicator of potential performance under conditions without seismic loading, such as steady-state. In addition, the critical slip circle with a FS lower than the target value is confirmed to a thin veneer within the CCW. This type of failure would not impact the integrity of the embankment."*

*Cross Section #1, located on the southern embankment of the Coal Pile Runoff, indicated a minimum factor of safety of 1.4 for the downstream steady-state model with a maximum surcharge pool conditions. MACTEC estimated the location and shape of the predicted critical slip circle "would impact the embankment, and would occur within the soft fill and alluvium located between approximately Elevation 385 and 371 feet NGVD." In addition, MACTEC recommends various methods for improving the minimum factor of safety such as installation of a rock buttress on the downstream slope.*

*Cross-Section #5, located on the eastern embankment of Ash Treatment Basin #2, indicated a minimum factor of safety of 0.8 (targeted FS of 1.0) under seismic loading conditions. MACTEC estimates the predicted failure occurs as a "thin veneer failure within the impounded ash behind the embankment and would have an insignificant impact on the embankment."*

*In addition, MACTEC states in their conclusion section that based on the results of our (MACTEC) stability analyses, we have concluded that the embankment sections analyzed are structurally stable under steady-state conditions from a slope stability standpoint, and are not in danger of imminent failure. However, one slope under steady-state/maximum surcharge conditions (Section 1 Downstream) and one slope under seismic loading conditions (Section 5 Upstream) do not meet the target FS criteria provided and referenced herein.*

### **3.4 Foundation Conditions**

MACTEC's report entitled *Geotechnical Exploration and Slope Stability Analyses Data Package, Kentucky Utilities (KU), Green River Power Station, Number 2 Pond & Scrubber Pond, South Carrolton, Muhlenburg County, Kentucky* prepared by MACTEC Engineering and Consulting, Inc dated September 3, 2010 briefly describes foundations conditions. The report states "In general, the dikes were constructed of sandy clay fill reportedly excavated from the incised

portion of the ponds. The fill was placed overlying existing alluvial soils comprised of silty to sandy, lean clay." Geotechnical borings performed in 1975 and 1976 by H.C. Nutting Company indicate the natural soils in the area of the Coal Pile Runoff Pond and the Ash Treatment Basin #2 consist of silty to sandy, clays with varying amounts of rock fragments overlying sandstone. The 2010 Associated Engineers, Inc. stability report for the Ash Treatment Basin #1 and repair area encountered foundation soils described as lean clay to sandy lean clay variably grading to silty clay with variable sand content.

### 3.5 Operations and Maintenance

According to Kentucky Utilities, personnel perform weekly safety and surveillance inspections for the ash ponds at the Green River Power Station. KU only provided three weekly inspection reports beginning at the end of July, 2010 as documentation. ATC Associates performed inspections on the ash ponds in October 2009. The reports indicated areas of surface erosion, soil sediment build-up in seepage pipes, a scarp on the main ash pond south embankment, animal burrows, steep slopes, and un-vegetated areas. See section 3.5.2 for further details regarding the ATC inspections. Several of the issues appeared to be addressed at the time of the site visit. No safety issues were reported in the documented reports that were reviewed. The site visit and observation performed by AMEC in August 2010 showed no major operational or maintenance issues that needed to be addressed.

#### 3.5.1 Instrumentation

During Associated Engineers Ash Treatment Basin #1 slope stability analysis, piezometers were installed in borings P2, P2A, P3, and P4 as part of the overall dam stability investigation; and, borings P1, P1A, and P5 were drilled and completed as standpipe piezometers located at the area of the slope failure. It was noted that in P5, installed below the toe of the recent slope failure, water was measured over 2 feet above ground level indicating a hydraulic head at this location. Associated Engineers states that "it is possible that communication exists with water saturated in fly ash deposits below and upstream from the dam". After data collection was complete, piezometers P2 and P3 were removed from service through placement of cement grout backfill from the bottom of the boring upward. Associated Engineers noted that "accessibility issues" did not allow placement of borings/piezometers "along the downstream toe of the dam within an area generally between P2 and the previously described buttress." Figure 9 illustrates the piezometer locations for the Associated Engineers study.

Historically, impoundment monitoring equipment has not been used at the Green River Power Station. MACTEC Engineering installed six piezometers in support of the August 2010 slope stability analyses (subsequent to AMEC's site inspection). The piezometers were installed in Borings B-2C, B-3C, B-4C, B-6C, B-8C, and B-10C. Figure 12 illustrates the piezometer locations for the MACTEC study.

Piezometer information is summarized and shown in Table 20.

**Table 20. Piezometer Information**

Piezometer ID	Location	Boring Elevation	Screen Depth (BSG, ft)	Water Level Data	
				Elevation	Date
B-2C	Ash Treatment Basin #2	399.7	15-25	379.7	8/24/10
B-3C	Ash Treatment Basin #2	399.4	25.5-35.5	387	8/24/10
B-4C	Ash Treatment Basin #2	399.1	20-30	392.6	8/24/10
B-6C	Scrubber Pond	404.7	15-25	393.2	8/24/10
B-8C	Scrubber Pond	404.5	29-39	398.8	8/24/10
B-10C	Scrubber Pond	403.9	15-25	378.9	8/24/10
P-1	Ash Treatment Basin #1	449.30	46.2-51.2	437.34	3/8/10
P-1A	Ash Treatment Basin #1	449.29	17.5-25	438.35	7/2/10
P-2	Ash Treatment Basin #1	449.70		433.65	3/29/10
P-2A	Ash Treatment Basin #1	449.74	48-53	434.92	7/2/10
P-3A	Ash Treatment Basin #1	449.62	25-30	430.79	7/2/10
P-4	Ash Treatment Basin #1	412.69	5-10	409.18	7/2/10
P-5	Ash Treatment Basin #1	403.31	7-15	405.38	7/2/10

In summary, a total of 12 piezometers were placed at the Green River Ash Ponds in 2010 at the following locations: three at the main ash pond, three at the Ash Treatment Basin #2, three at the Scrubber Pond, and one at the Coal Runoff Pond. Two of the piezometers have been removed. Due to the recent installation of the instrumentation, a trend in the phreatic surface could not be noted at the time of the September 2010 Draft Report submittal.

KU provided, as part of their comments to the Draft Report, additional piezometer readings through January 2011. Those readings, for the instruments located in Ash Treatment Basin #2 and the Scrubber Pond, are summarized in Table 21.

**Table 21. Summary of Ash Treatment Basin #2 and Scrubber Pond Piezometer Readings**

Piezometer ID	Top of Ground Elevation (feet NGVD)	Bottom of Piezometer Elevation (Feet NGVD)	Date of Readings							
			8/24/10		10/14/10		12/8/10		1/14/11	
			Depth	Elevation	Depth	Elevation	Depth	Elevation	Depth	Elevation
			Feet (depth) / Feet NGVD (elevation)							
B-2C	399.7	374.7	10.2	389.5	10.5	389.2	8.7	391.0	9.1	390.6
B-3C	399.4	363.9	12.6	386.8	12.6	386.8	12.1	387.3	12.6	386.8
B-4C	399.1	369.1	6.9	392.2	8.0	391.1	7.8	391.3	7.9	391.2
B-6C	404.7	379.7	11.5	393.2	12.6	392.1	12.9	391.8	13.0	391.7
B-8C	404.5	365.5	15.1	389.4	13.7	390.8	12.8	391.7	12.9	391.6
B-10C	403.9	378.9	25.3	378.6	26.4	377.5	24.6	379.3	24.1	379.8

Note: Readings were taken from top of ground level.

### 3.5.2 Inspections

#### State Inspections

The Ash Treatment Basin #1 and Scrubber Pond are considered a Low Hazard dam by the Kentucky Division of Water. The Ash Treatment Basin #2, Finishing Pond #3, and the Coal Runoff Pond are not classified by the Kentucky Division of Water. State regulations indicate that KDOW will inspect Class A (low hazard) dams every 5 years, and Class B (moderate hazard) and Class C (high hazard) every 2 years. The regulations state that a Certificate of Inspection shall be issued to the dam owner upon completion of a successful inspection.

The most recent inspection performed by the Kentucky Division of Water at Green River Power Station, prior to submittal of the September 2010 Draft Report, was in November 2004. Review of the inspection indicated the Scrubber Pond required filling in of the low areas and re-grading the crest and all trees less than six inches in diameter removed from downstream slope. No documentation was provided to show that the State's recommendations/directives were addressed. No items were noted for the Ash Treatment Basin #1.

Following submittal of the September 2010 Draft Report, KDOW completed an inspection of Ash Treatment Basin #1 and the Scrubber Pond at the Green River Generating Station in early January 2011. Two deficiencies, as identified below, were noted as needing to be corrected for each of the ponds.

1. *Update reservoir storage capacity by providing stage-storage and stage-area data and all hydrologic data to perform a reservoir routing analysis (SITES) to determine structure's current storage capacity to pass the regulatory rainfall criteria for a low hazard dam without overtopping. Current pond area and natural drainage area to the pond will be included in the analysis. OR*
2. *Due to the recent slide repair on the downstream slope, continue monitoring for seepage and surface erosion.*

KDOW also issued a Certificate of Inspection for Dam and Appurtenant Works for each pond. It was noted by KDOW that backfilling of CCW "has occurred to within 5 to 6 feet of the crest" of Ash Treatment Basin #1. They further noted that the pond was originally designed with the capacity to hold both the regulatory freeboard hydrograph and coal ash, but that it is not clear whether recent hydrologic calculations have taken the current ash storage into account with respect to routing analyses and current capacity to pass the regulatory rainfall design.

#### 2009 and 2011 ATC Associates, Inc. Inspections

ATC Associates Inc. (ATC) completed an assessment of each pond at the Green River Power Station in October 2009 in a document entitled *Appendix D, Green River*.

KU provided, as part of their comments to the September 2010 Draft Report, additional documentation regarding an inspection that was conducted by ATC at the Green River facility in January 2011. The inspection report is entitled *2011 Pond Inspections Visual Site Assessment Report Six Impoundment Facilities*. As the report title suggests, ATC also performed visual assessments and inspections of other KU facilities at the time that the Green River work was conducted. As a result of that work, ATC was able to develop four general recommendations, described below, that were noted to apply to CCW containing ponds at all of the assessed facilities, including Green River.

1. Prepare or update an Operation and Maintenance Manual for the facility. (Normal Priority);
2. Continue regular facility inspections and provide training to personnel who will conduct the inspections. The training should include proper inspection techniques, the specific items that should be inspected, the frequency of inspections, and the documentation that is required. Part of the inspection process should include a yearly assessment by either outside consultants or LG&E or KU corporate personnel not routinely assigned to a power station. (High Priority);
3. Determine (for each pond) the maximum pool level that can be safely maintained to provide adequate freeboard capacity with the existing spillway configurations. The maximum elevation should then be surveyed and marked on each spillway inlet and documentation of the maximum water surface elevation should be included in the Operation and Maintenance manual. (High Importance); and,
4. Evaluate each pond facility with an embankment to determine whether a redundant method to prevent or safely control impounded water from overtopping the embankment crest is needed.

Specific conclusions and recommendations contained in the 2009 and 2011 Assessment Reports are summarized below. Overall assessment ratings were applied to each pond by ATC and are summarized in Table 22. Ratings and definitions provided in the ATC Reports include:

*Unsatisfactory - A dam safety deficiency exists for normal conditions. Immediate remedial action is required for problem resolution.*

*Poor - A potential safety deficiency is clearly recognized for normal loading conditions. Immediate actions to resolve the deficiency are recommended; reservoir restrictions may be necessary until problem resolution.*

*Conditionally Poor - A potential safety deficiency is recognized for unusual loading conditions which may realistically occur during the expected life of the structure. This designation may also be used when uncertainties exist as to critical analysis parameters which identify a potential dam safety deficiency; further investigations and studies are necessary.*

*Fair - No existing dam safety deficiencies are recognized for normal loading conditions. Infrequent hydrologic and/or seismic events would probably result in a dam safety deficiency.*

*Satisfactory - No existing or potential dam safety deficiencies recognized. Safe performance is expected under all anticipated loading conditions, including such events as infrequent hydrologic and/or seismic events. Project files contain necessary hydrologic and other engineering calculations to verify dam safety and performance.*



**Table 22. ATC Assessment - Pond Rating Summary**

Pond	2009 Rating	2011 Rating
Ash Treatment Basin #1 (Main Pond)	Poor	Fair
Ash Treatment Basin #2	Poor	Fair
Finishing Pond #3	Unsatisfactory	Fair
Scrubber Pond	Satisfactory	Fair
Coal Pile Runoff Pond	Fair	Fair

Both 2009 and 2011 Reports noted prioritized action items for each pond. Action item importance was prioritized as:

- High - indicating action should be addressed as soon as possible;
- Moderate - indicating action should be addressed during next construction season; and,
- Normal - indicating action should be part of ongoing maintenance at the structure.

The 2009 report noted a total of seventeen action items for Ash Treatment Basin #1 (Main Pond), while the 2011 Report noted ten. Each action item from both reports is summarized below in Table 23.

**Table 23. Ash Treatment Basin #1 Action Item Summary**

<b>Item No.</b>	<b>2009 High Importance Action Item(s)</b>
1	Evaluate stability of embankment under steady state, and earthquake loading.
2	Monitor existing scarp on downstream slope for changes, maintain lower water level in pond until repairs to scarp are made.
	<b>2011 High Importance Action Item(s)</b>
1	Clearly mark highest allowable stoplog elevation on principal spillway inlet. Elevation to be determined by others. Include instruction in Operating Manual for pond.
	<b>2009 Moderate Importance Action Item(s)</b>
1	Mow interior slope of entire pond and spray with herbicide.
2	Cut woody vegetation on exterior dam face and mow remaining areas not mowed at end of 2009. Mow 20 feet below exterior toe of slope.
3	Inspect entire interior slope after mowing for presence of burrowing animals. Potential locations of burrow are noted.
4	Repair and re-establish vegetation in areas damaged by mowing equipment.
5	Fill in and revegetate erosion gullies on exterior slope.
6	Armor groin ditch west end of south embankment below culvert outlet.
7	Armor groin ditch east end of south embankment below toe.
8	Clean out 5 seepage pipe drains to promote rapid drainage and remove accumulated material from pipe interior.
9	Install permanent outlet protection for 5 seepage pipes.
10	Repair scarp on downstream slope of south embankment, approximately 120 feet in length.
11	Evaluate presence of wet areas on south embankment, approximately 120 feet in length.
	<b>2011 Moderate Importance Action Item(s)</b>
1	Repair and re-establish vegetation in areas reworked in fall of 2010, numerous locations.
2	Enlarge and armor remaining portion of groin ditch on west end of south embankment below culvert outlet.
3	Rework culvert inlet at exterior toe, west side of south embankment. Culvert inlet is clogged with vegetation.
4	Evaluate presence of wet areas on south embankment including area near piezometer P5 <sup>1</sup> , monitor for changes in seepage. Piezometer showing piezometric head 2 feet above ground level at toe.
5	Repair concrete culvert inlet at coal pile storage area. Inlet is crushed and partially clogged with loose coal.
6	Rework drainage below new seep collection pipe outlet. Ditch below pipe outlet partially filled with loose coal allowing water to pond in outlet pipe. Mineral buildup in pipe will prevent drainage of collected seepage water.
	<b>2009 Normal Importance Action Item(s)</b>
1	Repair animal burrows along south embankment.
2	Regrade drain at toe of west slope to prevent ponding of water.
3	Re-position ash discharge pipes into existing concrete cradle up exterior slope.
4	Place rip rap at culvert outlet to protect and mark area for mowing (at west end).

<b>2011 Normal Importance Action Item(s)</b>	
1	Add slope erosion protection along interior of west embankment where exposed to pond water.
2	Move discharge for new ash line on east interior slope at least 10 feet from slope to prevent potential erosion to interior slope.
3	Cut vegetation at toe of south embankment and 10 feet beyond toe.

<sup>1</sup> 2011 Inspection, Moderate Importance, Item 4 - Piezometer changed to P5 per email from KU dated 4/13/2011.

The July 14, 2010 report entitled *Final Geotechnical Report, Main Ash Pond, Slope Stability Analysis and Repair, Green River Station*, prepared by Associated Engineers, Inc., discusses the stability of the entire Main Ash Pond dam along with analysis and design recommendations specific to the recent (2010) slope repair activities. The southern slope of the Main Ash Pond was repaired in May and June of 2010 under the observation of Associated Engineers, Inc. based on their evaluations they consider 2009 recommended action items 1 and 2 above to be cleared.

Following the 2011 inspection, ATC's assessing engineer noted "Substantial improvements [have been ] made since [the] last ATC inspection."

The 2009 ATC Assessment Report noted a total of eighteen action items with respect to Ash Treatment Basin #2. The 2011 ATC Report noted a total of four action items. Each item from both years' reports is summarized below in Table 24.

**Table 24. Ash Treatment Basin #2 Action Item Summary**

Item No.	2009 High Importance Action Item(s)
1	Reduce and maintain pool level to provide at least 2 feet of freeboard.
2	Perform elevation survey of dam crest elevations. Place fill as needed to return crest to design elevation.
3	Mark principal spillway to prevent stop log placement which would result in overtopping of crest.
4	Perform hydrologic and hydraulic analysis of pond to evaluate need for secondary spillway to prevent pond overtopping (24" freeboard).
5	Evaluate need to armor east embankment toe along outfall channel, flow in channel eroding vertical scarps into toe.
6	Trap and remove burrowing animals from pond.
7	Perform stability analysis of east embankment.
8	Dress up exterior slope of south embankment after completion of tree removal.
9	Remove or grout dredge cell inlet pipe, upstream of pond embankment.
<b>2011 High Importance Action Item(s)</b>	
1	Place fill as needed to return crest to design elevation. Elevation survey by others indicates crest elevations vary up to 1.5 feet.
2	Place filter over observed seep at west end of south embankment at boring drilled in 2010 (B-1.75T) to prevent piping and loss of soil.
3	Mark principal spillway to prevent stop log placement which would result in overtopping of the crest.
<b>2009 Moderate Importance Action Item(s)</b>	

1	Repair animal burrows along east embankment.
2	Mow vegetation on exterior slope and around principal spillway outlet.
3	Cut vegetation on interior slope, spray with herbicide.
4	Perform follow up assessment of slopes after vegetation is removed for wave erosion and burrowing animals.
5	Repair scarps along exterior slope of south end of east embankment.
6	Repair erosion at Principal Spillway outfall channel, flow eroding east toe exposing 5 feet vertical scarp.
7	Repair erosion at south end of east toe, outfall channel flow eroded embankment toe exposing 4 feet vertical scarp approx. 100 feet in length.
8	Move spillway discharge channel away from east embankment toe. Erosion of embankment toe occurring along full length of east exterior slope.
<b>2011 Moderate Importance Action Item(s)</b>	
1	Place erosion protection at waterline of interior slopes.
<b>2009 Normal Importance Action Item(s)</b>	
1	Evaluate need to include pond on KY inventory of dams.

The assessing professional engineer's comments concerning the overall condition of the pond in 2009 included;

*considerable slope maintenance required both for interior and exterior slopes. Crest elevation needs to be determined and low areas filled. Movement of outfall ditch from toe of east slope is needed to prevent erosion of toe. Flattening of slopes to allow mowing should be considered. Minimum freeboard requirement should be established based on hydraulic and hydrologic evaluation of spillway/impoundment. Secondary spillway may be needed. Perform stability analysis of east slope due to numerous scarps present on slopes.*

Following the 2011 inspection, ATC's assessing engineer noted "Substantial improvements [have been] made since [the] last ATC inspection."

The 2009 ATC Assessment Report noted a total of 18 action items with respect to Finishing Pond #3. The 2011 ATC Assessment Report did not assess Finishing Pond #3 because, as was noted in the Report, it was "taken out of service in 2010 and no longer impounds water." Action items from 2009 are summarized below in Table 25.

**Table 25. Finishing Pond #3 Action Item Summary**

Item No.	2009 High Importance Action Item(s)
1	Clean vegetation and remove curtain around principal spillway inlet for skimmer.
2	Repair numerous animal burrows in slopes.
3	Place aggregate berm against exterior slope in area of old discharge channel, slope near vertical, over 20 feet high.
4	Perform hydraulic and hydrologic analysis of pond to evaluate Principal Spillway and freeboard requirements.
5	Evaluate stability of vertical slope below Principal Spillway discharge.

Item No.	2009 High Importance Action Item(s)
6	Perform stability analysis of pond embankment.
7	Cut vegetation and trees along south and east interior slopes.
8	Evaluate stability enhancement and erosion resistance provided by trees and vegetation along Green River bank to determine whether to cut trees.
9	Evaluate frequency and depth of inundation from Green River flood events. Perform rapid drawdown stability evaluation of slope facing Green River.
2009 Moderate Importance Action Item(s)	
1	Design modifications to dam cross section to improve stability.
2	Evaluate need for secondary spillway to prevent pond overtopping.

The assessing professional engineer's comments concerning the overall condition of the pond in 2009 included;

*recommend evaluation whether dam should be breached or repaired and kept in service. Evaluation in progress during inspection.*

The 2009 ATC Assessment Report noted a total of eight action items with respect to the Scrubber Pond. The 2011 ATC Report noted a total of five action items. Each item from both years' reports is summarized below in Table 26.

**Table 26. Scrubber Pond Action Item Summary**

Item No.	2009 Moderate Importance Action Item(s)
1	Re-vegetate areas damaged by mowing and construction equipment.
2	Cut vegetation on interior slope and spray with herbicide.
3	Inspect entire interior slope after cutting vegetation for wave erosion and burrowing animals, repair as necessary.
4	Evaluate need for gravity fed spillway to prevent overtopping.
5	Replace roadbed aggregate on crest access road to fill in ruts and eliminate ponding water.
2011 Moderate Importance Action Item(s)	
1	Re-seed areas where sparse vegetation exists on exterior slopes.
2	Add erosion protection on all interior slopes at waterline, restore slope configuration where eroded by wave action.
3	Evaluate need for spillway to prevent overtopping.
4	Fill low areas on dam crest to maintain consistent freeboard depth. Elevation survey by others indicates one foot variation is present.
2009 Normal Importance Action Item(s)	
1	Repair erosion gully on downstream slope at SW corner.
2	Mow vegetation on east embankment exterior slope and east end of south embankment.
3	Regrade area south of pond to prevent ponding water.
2011 Normal Importance Action Item(s)	
1	Regrade area south of pond to prevent ponding water.

Following the 2011 inspection, ATC's assessing engineer noted "Substantial improvements [have been] made since [the] last ATC inspection. Interior slope vegetation cut prior to inspection allowing extent of old wave erosion to interior slope to be observed."

The 2009 ATC Assessment Report noted a total of eight action items with respect to the Coal Runoff Pond. The 2011 ATC Report noted a total of six action items. Each item from both years' reports is summarized below in Table 27.

**Table 27. Coal Runoff Pond Action Item Summary**

Item No.	2009 Moderate Importance Action Item(s)
1	Dress up exterior slope of south embankment after tree removal, establish grass vegetation.
2	Repair old scarp on south embankment.
3	Mow vegetation on interior and exterior slopes and remove trees.
4	Cut trees flush with ground on all interior and exterior slopes, establish grass cover after cutting.
5	Flatten south exterior slope, currently too steep.
6	Clear vegetation and clear sediment from intake on spillway to Ash Pond 2 ( <i>Ash Treatment Basin #2</i> ).
2011 Moderate Importance Action Item(s)	
1	Excavate sediment accumulated at intake to spillway to prevent clogging and growth of vegetation.
2009 Normal Importance Action Item(s)	
1	Perform hydrologic and hydraulic analysis on pond to evaluate need for secondary spillway to prevent pond overtopping.
2	Evaluate support needed for 2 HDPE ash lines to Main Ash Pond on west embankment, approximately 8 foot long section is undermined near north end of west embankment.
2011 Normal Importance Action Item(s)	
1	Monitor area of old scarp on south embankment exterior for signs of movement.
2	Cut remaining woody vegetation on interior slope of west embankment. Cut trees flush with ground, then establish grass cover.
3	Evaluate grade support needed for 2 HDPE ash lines to Main Ash Pond, approximately 8 foot long section is undermined near north end of west embankment.
4	Repair concrete inlet pipe from coal storage yard to coal runoff pond. Pipe inlet is crushed and partially filled with coal.

The assessing professional engineer's comments concerning the overall condition of the pond in 2009 included;

*some maintenance required. After cutting of trees is complete, establishment of grass on slopes is needed to prevent erosion. Repair and flattening of exterior slope may be needed on south embankment in area of previous scarp.*

Following the 2011 inspection, ATC's assessing engineer noted "Substantial improvements [have been] made since [the] last ATC inspection. Continue to monitor slopes for rodent activity."

## 4.0 COMMENTS AND RECOMMENDATIONS

Condition assessment definitions, as accepted by the National Dam Safety Review Board, are as follows:

### **SATISFACTORY**

No existing or potential dam safety deficiencies are recognized. Acceptable performance is expected under all loading conditions (static, hydrologic, seismic) in accordance with the applicable regulatory criteria or tolerable risk guidelines.

### **FAIR**

No existing dam safety deficiencies are recognized for normal loading conditions. Rare or extreme hydrologic and/or seismic events may result in a dam safety deficiency. Risk may be in the range to take further action.

### **POOR**

A dam safety deficiency is recognized for loading conditions which may realistically occur. Remedial action is necessary. POOR may also be used when uncertainties exist as to critical analysis parameters which identify a potential dam safety deficiency. Further investigations and studies are necessary.

### **UNSATISFACTORY**

A dam safety deficiency is recognized that requires immediate or emergency remedial action for problem resolution.

### **NOT RATED**

The dam has not been inspected, is not under state jurisdiction, or has been inspected but, for whatever reason, has not been rated.

EPA received Draft Report response comments from KU (January 26, 2011) and KDOW (January 31, 2011). Both parties take exception to (1) the assignment of a condition assessment rating to these ponds and (2) criteria for assignment of the rating. AMEC utilized the resources and guidelines provided by EPA for this work.

#### **4.1 Acknowledgement of Management Unit Conditions**

I certify that the management units referenced herein (Ash Treatment Basin #1 or Main Pond, Ash Treatment Basin #2, Finishing Pond #3, Scrubber Pond, and the Former Ash Pond or Coal Runoff Pond) were personally assessed by me and were found to be in the following condition:

#### **Ash Treatment Basin #1 or Main Pond: Fair**

The Ash Treatment Basin #1 or Main Pond was rated poor in the Draft Report because, in AMEC's opinion, further critical studies or investigations were needed to identify potential dam safety deficiencies.



Based upon the information provided by Kentucky Utilities on January 26, 2011 the pond is now rated Fair because, in AMEC's opinion, no existing dam safety deficiencies are recognized for normal loading conditions, but rare or extreme hydrologic events may result in a dam safety deficiency. Risk may be in the range to take further action. In addition, historic and recent surface slope repairs, wet conditions at piezometer P-5 below the recent slope repair, series configuration and location above Ash Treatment Basin #2 warrants a conservative rating and diligent monitoring of the impoundment by Kentucky Utilities.

### **Ash Treatment Basin #2: Poor**

The Ash Treatment Basin #2 was rated poor in the Draft Report because, in AMEC's opinion, further critical studies or investigations were needed to identify potential dam safety deficiencies.

Based upon the information provided by Kentucky Utilities on January 26, 2011, in AMEC's opinion, the pond rating is unchanged due to potential dam safety deficiencies identified in *Addendum A* to the August 12, 2010 report entitled *Assessment of Spillway Hydrologic Adequacy for the Coal Pile Pond, Ash Treatment Basin No. 2, and Scrubber Pond at Green River Generating Station*. The addendum notes overtopping of the pond under KDOW guidelines and provides two potential measures to bring ATB 2 into compliance. In addition, it is AMEC's opinion the location of ATB 2 below the relatively large Main Pond and series configuration of the impoundments at the site resulting in ATB 2 receiving discharge from all the other ponds warrants extreme conservatism in hazard classification, analyses and ratings.

### **Scrubber Pond: Fair**

The Scrubber Pond was rated poor in the Draft Report because, in AMEC's opinion, further critical studies or investigations were needed to identify potential dam safety deficiencies.

Based upon the information provided by Kentucky Utilities on January 26, 2011, in AMEC's opinion, the pond is now rated Fair because of steps taken by KU to improve the operation and hydraulics of the impoundment including the installation of higher capacity automatic pumps and lowering of the normal operating water level. A history of surface failures, relatively steep slopes including approximate 2.2:1 south slopes, soft foundation soils under the south slope and the low lying area below the south slope warrant a conservative rating and continued monitoring of the impoundment by Kentucky Utilities.

### **Former Ash Pond (or Coal Runoff Pond): Poor**

The Former Ash Pond (or Coal Runoff Pond) was rated poor in the Draft Report because, in AMEC's opinion, further critical studies or investigations were needed to identify potential dam safety deficiencies.

Based upon the information provided by Kentucky Utilities on January 26, 2011, in AMEC's opinion, the pond rating is unchanged due to potential dam safety deficiencies identified in the final stability report.

### **Former Finishing Pond #3: Not Rated**

The Former Finishing Pond #3 is not rated because it was removed from service in 2010. Removal from service included regrading/removal of the dike. Since there is not a feature to

impound water the potential to fail will not occur. AMEC understands ash was not removed from within the interior of the pond when the dike was removed. Any ash present within the area of Former Finishing Pond #3 that can be feasibly removed should be excavated and stored in one of the other ash ponds.

## 4.2 Ash Treatment Basin #1 or Main Pond

### 4.2.1 Hydrologic and Hydraulic Recommendations

#### September 2010 Draft Report

An August 2010 report by MACTEC Engineering and Consulting, Inc. titled *Assessment of Spillway Hydrologic Adequacy for the Coal Pile Pond, Ash Treatment Basin No. 2, and Scrubber Pond at Green River Generating Station* provides a hydrologic analysis that is specific to Ash Treatment Basin #1. Design storm events of various returns periods and of various durations, including 6 hours, 24 hours and 48 hours, were used in the analyses. Additionally, MACTEC's report was unclear if the present ash material located in the pond profile was included in their analysis. MACTEC noted in their report that while Ash Treatment Basin #1 is not a structure subject to investigation, analysis of Ash Treatment Basin #1 was required for their analysis and it was found to have a minimum freeboard of 1.54 ft for the DNREP-DOW Class A freeboard design hydrograph (FDH) and a freeboard of 2.11 ft for the 100-year, 48-hour design storm event.

AMEC recommends that an appropriately conservative design storm rainfall and freeboard depth in accordance with MSHA guidelines be applied to the impoundment,s watershed to assure that the dam and decant system can safely store, control, and discharge the design flow. Based on the large size and significant rating for Ash Treatment Basin #1, the MSHA design storm would be the PMF. Hydraulic calculations should also be completed to determine the rate at which the discharge structure and associated piping could pass the design storm, if necessary, or draw down elevated water surfaces following such an event. The study should consider all critical stages over the life of the pond including pond full conditions. MSHA guidelines recommend a minimum freeboard of 3 feet. Since Ash Treatment Basin #1 discharges into Ash Treatment Basin #2, MSHA's guidelines for impoundments in series should be utilized.

#### Final Report

In comments included in the January 26, 2011 response to the draft report by Kentucky Utilities and comments from Kentucky Department of Water to EPA dated January 31, 2011 both parties take exception to the use of MSHA guidelines to evaluate CCW impoundments. AMEC followed the guidelines presented in our scope of work for assessment of CCW impoundments which was provided by EPA.

AMEC acknowledges the hydraulic studies for Ash Treatment Basin #1 indicate the impoundment meets KDOW requirements. However, based on past and recent surface slope failures on the south embankment, the wet area noted in inspection reports at piezometer P5 (toe of south embankment), consistent elevated water readings in piezometers P5 and the layout of the impoundments at the site (i.e. structures in series configuration), AMEC recommends Kentucky Utilities evaluate the need to (1) temporarily lower the normal operating level of Ash Treatment Basin #1 until the recent slope repair and wet area below the repair have been assessed and (2) permanently increase the available freeboard to provide adequate safety

based on sound engineering judgment for the operation of all the impoundments particularly in light of the “structures in series” configuration of the impoundments.

#### 4.2.2 Geotechnical and Stability Recommendations

##### September 2010 Draft Report

In the opinion of the assessing professional engineer, the criteria for minimum safety factors should be in accordance with USACE EM 1110-2-1902 with a minimum seismic safety factor of 1.2 as recommended by 2007 *MSHA Coal Mine Impoundment Inspection and Plan Review Handbook*, page 88. Likewise, if the dam does not meet the above seismic factor of safety, then the stability of the embankment should be analyzed and the amount of embankment deformation or settlement that may occur should be evaluated to assure that sufficient section of the crest will remain intact to prevent a release from the impoundment.

A July 2010 report by Associated Engineers, Inc. titled *Final Geotechnical Report Main Ash Pond Slope Stability Analysis and Repair*, for the Green River Station presents two stability analyses for Ash Treatment Basin #1 including a slope failure located on the downstream slope of the south embankment north of the outlet structure, and a global stability (also referred to as critical slope). Based on the results and recommendations in this report, the slope failure was repaired during May and June of 2010.

The repair stability adjusts the friction and phi angle for the material above the ground surface from elevation 385 feet to 393 feet. However, the report notes the slide extending down to approximate elevation 400 feet. From elevation 393 feet to 402 feet a fly ash and clay material was encountered. On the boring log for P-1, this material within the embankment is described as wet. The report also notes that the water levels observed in the piezometer installed in Boring P-5 below the toe of the slide were up to two feet above the pipe and stated there must be a connection between the fly ash in the embankment and fly ash below the slope. It is assumed that the lowering of the parameters in the layer above the bedrock by “backing in” to a safety factor of less than 1 and then designing a repair with a safety factor over 1.5 will compensate for the failure and that the repair will provide adequate stability. This area should be regularly and closely monitored for any changes in piezometers readings or surficial movement.

The global stability was reviewed for the maximum section at B-B'. The dam at cross section B-B' was noted to have a maximum height (from crest to downstream toe), and to contain close to a maximum thickness of fill material (measured from the top of the dam vertically downward). The results of the stability analyses provided factors of safety of 1.6 for long-term and 1.3 for seismic conditions. A review of the slopes used for the downstream embankment indicated about a 2.7H:1V was used in the analyses. The design slope for the downstream embankment is 2.5H:1V. During the site visit, this area was noted for possible uneven and over-steepened slopes. A survey should be performed at the cross-section to determine the actual configuration of the existing slope. In addition, the minimum depth of slice used in the program was 10 feet. The analysis should be performed with a 5 feet minimum depth of slice to identify shallow failure surfaces.

The analysis should consider all critical stages over the life of the pond including pond full conditions. These conditions would need to be determined in conjunction with the hydraulic recommendations above. The hydraulic analysis should provide a phreatic surface through the embankment. A rapid-drawdown should be performed for the A-A' section in case the pond

would need to be lowered in response to a problem. The friction angle value used for the CCW in the analysis appears high for ash material. Typical ash friction values are 28 degrees for compacted, 24 degrees for loosely compacted, and 11 degrees for uncompacted material. Consideration should be given for lowering strength values to account for inconsistencies within the fill or foundation materials. Consideration should also be given to allow water levels in the piezometers to develop and stabilize. The analyses presented appear limited to a circular surface; different types of failure surfaces should be analyzed and optimized.

In the opinion of the assessing professional engineer, the analyses should be revised in accordance with these recommendations. The analysis should consider all critical stages over the life of the pond including pond full conditions. These conditions would need to be determined in conjunction with the hydrologic and hydraulic recommendations above. The hydrologic and hydraulic analysis will provide maximum water levels in the pond and a phreatic surface through the embankment.

#### Final Report

In comments included in the January 26, 2011 response to the draft report by Kentucky Utilities and comments from Kentucky Department of Water to EPA dated January 31, 2011 both parties take exception to the use of MSHA guidelines to evaluate CCW impoundments. AMEC followed the guidelines presented in our scope of work for assessment of CCW impoundments which was provided by EPA.

AMEC acknowledges the stability studies performed for Ash Treatment Basin #1 indicate the impoundment meets KDOW requirements. However, based on past and recent surface slope failures on the south embankment, the wet area noted in inspection reports at piezometer P5 (toe of south embankment below recent repair), consistent elevated water readings in piezometers P5 and the layout of the impoundments at the site (i.e. structures in series configuration), AMEC recommends Kentucky Utilities evaluate the need to (1) temporarily lower the normal operating level of Ash Treatment Basin #1 until the recent slope repair and wet area have been assessed and (2) permanently increase the available freeboard to provide adequate safety based on sound engineering judgment for the operation of all the impoundments particularly in light of the "structures in series" configuration of the impoundments.

#### **4.2.3 Monitoring and Instrumentation Recommendations**

##### September 2010 Draft Report

Twelve piezometers, of which 10 are remaining, were installed in 2010 (July and August) to support the recent stability analyses. It would be prudent for the Green River Power Station to maintain and protect these instruments, and document monitoring frequently until base line phreatic readings are apparent. After that time, a regular frequency should be maintained and the results evaluated by an engineer. Monitoring should include pond and river levels and should include additional readings and evaluation in response to elevated pond levels or specific rainfall events. AMEC recommends additional instrumentation, especially at the crest and toe of critical slopes, be installed as budgets or development of any future problems allow.

##### Final Report

Kentucky Utilities continues to monitor the piezometers at Ash Treatment Basin #1 as evidenced by the two additional sets of readings provided in *Addendum A* to the stability report

(submitted with KU's comments to the Draft report). AMEC reiterates the recommendations made in our Draft report especially the inclusion of pond and river levels data. Elevated water levels in P-5 and the wet area in this same area should be continuously monitored and evaluated.

#### 4.2.4 Inspection Recommendations

##### September 2010 Draft Report

AMEC has reviewed provided information and inspection records for the Green River Ash Ponds: Ash Treatment Basin #1, Ash Treatment Basin #2, Scrubber Pond and Coal Runoff Pond and determined that Kentucky Utilities has begun adequate inspection practices. Finishing Pond #3 was removed from service in 2010, therefore, no inspection services have been provided for this pond. AMEC recommends that the current inspection program by the plant be expanded to include at least monthly instrumentation monitoring and pond and river levels.

AMEC has reviewed the 2009 inspection reports and determined Kentucky Utilities has adequate annual inspections by a Profession Engineer. In addition to the inspections by facility personnel, we recommend this type of annual inspection program and report by a Professional Engineer be continued at least yearly basis. Due to the recent slide repair on the south dike of Ash Treatment Basin #1 and the Coal Runoff Pond, the recent surficial slide repair at the southwest corner of the Scrubber Pond and recent repair of the east dike of Ash Treatment Basin #2, AMEC recommends additional inspections be performed by Professional Engineer should any problems, such as seepage, scarps, etc., be encountered with the repairs or if new similar problems develop.

##### Final Report

The January 2011 inspection by ATC for Ash Treatment Basin #1 generally identified normal maintenance type items. KU's response to the Draft report stated they are *developing plans to address the priority maintenance items in 2011*. AMEC recommends KU personnel perform frequent inspections of the embankments with special attention to the wet area identified at piezometer P5.

#### 4.3 Ash Treatment Basin #2

##### 4.3.1 Hydrologic and Hydraulic Recommendations

##### September 2010 Draft Report

An August 2010 report by MACTEC Engineering and Consulting, Inc. titled *Assessment of Spillway Hydrologic Adequacy for the Coal Pile Pond, Ash Treatment Basin No. 2, and Scrubber Pond at Green River Generating Station* provides a hydrologic analysis that is specific to Ash Treatment Basin 2. Design storm events of various returns periods and of various durations, including 6 hours, 24 hours and 48 hours, were used in the analyses. The analyses for Ash Treatment Basin #2 indicated a minimum freeboard of -0.73 ft for the DNREP-DOW Class A freeboard design hydrograph (FDH) and a freeboard of -0.33 ft for the 100-year, 48-hour design storm event.

AMEC recommends that an appropriately conservative design storm rainfall and freeboard depth in accordance with MSHA guidelines be applied to the impoundment,s watershed to

assure that the dam and decant system can safely store, control, and discharge the design flow. Based on the small size and significant rating for Ash Treatment Basin #2, the MSHA design storm would be the ½ PMF. Hydraulic calculations should also be completed to determine the rate at which the discharge structure and associated piping could pass the design storm, if necessary, or draw down elevated water surfaces following such an event. The study should consider all critical stages over the life of the pond including pond full conditions. MSHA guidelines recommend a minimum freeboard of 3 feet. In addition, Ash Treatment Basin #2 will be required to utilize MSHA's guidelines for impoundments in series.

### Final Report

In comments included in the January 26, 2011 response to the Draft report by Kentucky Utilities and comments from Kentucky Department of Water to EPA dated January 31, 2011 both parties take exception to the use of MSHA guidelines to evaluate CCW impoundments. AMEC followed the guidelines presented in our scope of work for assessment of CCW impoundments which was provided by EPA.

In AMEC's opinion, as supported by a normal action item included in ATC's October 2009 Assessment of Ash Treatment Basin #2, KDOW should investigate this impoundment, based on its size, for inclusion in the Kentucky Inventory of Dams. At 345 acre-feet, the impoundment far exceeds the KDOW minimum size criteria for dams. Additionally, this impoundment is located downstream of (series configuration), and receives flow from the larger Ash Treatment Basin #1. The location and series operating conditions should be taken into account by KDOW in any rating assigned to Ash Treatment Basin #2.

MACTEC's *Addendum A* (January 25, 2011) to their August 12, 2010 report entitled *Assessment of Spillway Hydrologic Adequacy for the Coal Pile Pond, Ash Treatment Basin No. 2, and Scrubber Pond at Green River Generating Station* details possible modifications to Ash Treatment Basin #2 to eliminate overtopping of the existing crest by the KY Class A Freeboard Design Hydrograph 100-year 24-hour storm event, as shown through hydraulic modeling. Use of storms larger than the 100-year 6-hour is a step in the right direction, but in AMEC's opinion, identification of a remaining "freeboard" of 0.04 feet (Alternative 1) is not acceptable. MSHA, along with other acceptable hydrologic and hydraulic design guidelines, indicate minimum "freeboard" depths of three feet as adequate. Further, freeboard is understood to be the vertical distance above the design storm water surface elevation and the crest of an impoundment. In order to obtain a more reasonable "freeboard" in Ash Treatment Basin No. 2, AMEC recommends modeling, at minimum, the 100-year 24-hour design storm in the KDOW Freeboard Design Hydrograph to obtain a resulting water surface elevation. Once the resulting water surface elevation is determined from the routed Freeboard Design Hydrograph, a minimum of at least two feet should separate that design storm water surface elevation and the crest of the impoundment. MSHA guidelines (rare or extreme hydrologic conditions) would not be met, but the level of protection for the river, as well as the retention capacity of the impoundment, would be greatly improved over existing conditions.

A hydrologic and hydraulic report should be produced for Ash Treatment Basin No. 2 that clearly identifies all factors, flows, calculations, and results, including available freeboard, for the impoundment.

### 4.3.2 Geotechnical and Stability Recommendations

#### September 2010 Draft Report

In the opinion of the assessing professional engineer, the criteria for minimum safety factors should be in accordance with USACE EM 1110-2-1902 with a minimum seismic safety factor of 1.2 as recommended by 2007 MSHA Coal Mine Impoundment Inspection and Plan Review Handbook, page 88. Likewise, if the dam does not meet the above seismic factor of safety, then the stability of the embankment should be analyzed and the amount of embankment deformation or settlement that may occur should be evaluated to assure that sufficient section of the crest will remain intact to prevent a release from the impoundment.

A September 2010 report by MACTEC Engineering and Consulting, Inc. titled *Geotechnical Exploration and Slope Stability Analyses Data Package*, for the Green River Power Station presents stability analyses for Ash Treatment Basin #2 and the Scrubber Pond. Five sections were chosen for analyses on each structure. Section 1 is located on the south embankment of the Coal Runoff Pond. Sections 2 through 5 are located at Ash Treatment Basin #2 on the south embankment (2), southeast corner (3) and east embankment (4 and 5). Sections 6 through 10 are located at the Scrubber Pond on the west embankment (6), south embankment (7 and 8), southeast corner (9) and east embankment (10). For this preliminary report, results for sections 4 and 7 were presented.

Section 4 is located on the east embankment of Ash Treatment Basin #2. AMEC is concerned with the configuration and soil strength parameters used in the analyses. The 2009 ATC inspection report noted erosion in the outfall channel which had eroded the eastern toe of this slope. During AMEC's site visit in August 2010, the downstream embankment on the east dike was observed to be recently repaired with a rip-rap surface and the outfall channel had been relocated to the east of the toe. AMEC also observed wet/saturated areas along the eastern toe of this slope, this area was discussed with the personnel listed in Table 1 of this report. We were informed while onsite the wet/saturated soils were due to improper grading (i.e., water standing from a recent rain event); however, AMEC recommends this section be reviewed for existing conditions and parameters adjusted to reflect softer conditions at the toe. The wet areas may also reflect seepage from the pond; and therefore, higher water levels would need to be utilized in the pond and embankment analyses. In addition, soft layers of clay and ash were shown in the Section 2 borings, other sections yet to be analyzed may be more critical. Consideration should also be given to the extension of the south embankment and construction of the east embankment (estimated to be performed in the early 1970s). Construction documents and construction details are very limited from this era. As evidenced by the ash encountered in the Section 2 borings, it is suspected that portions of the extension and formation of Ash Treatment Basin #2 were constructed over and possibly with the CCW material. Consequently, embankments constructed over ash would be susceptible to piping and slope failures.

The analysis should consider all critical stages over the life of the pond including pond full conditions. These conditions would need to be determined in conjunction with the hydraulic recommendations above. The hydraulic analysis should provide a phreatic surface through the embankment. A rapid-drawdown should be performed for upstream embankment in case the pond would need to be lowered in response to a problem, and the downstream embankment in relation to flooding of Green River. The friction angle value used for the CCW in the analysis appears high for ash material. Typical ash friction values are 28 degrees for compacted, 24 degrees for loosely compacted, and 11 degrees for uncompacted material. Consideration

should be given for lowering strength values to account for inconsistencies within the fill or foundation materials. Consideration should also be given to allowing some time for water levels in the piezometers to develop and stabilize. The analyses presented appear limited to a circular surface; different types of failure surfaces should be analyzed and optimized.

In the opinion of the assessing professional engineer, the analyses should be revised in accordance with these recommendations. The analysis should consider all critical stages over the life of the pond including pond full conditions. These conditions would need to be determined in conjunction with the hydrologic and hydraulic recommendations above. The hydrologic and hydraulic analysis will provide maximum water levels in the pond and a phreatic surface through the embankment.

#### Final Report

In comments included in the January 26, 2011 response to the Draft report by Kentucky Utilities and comments from Kentucky Department of Water to EPA dated January 31, 2011 both parties take exception to the use of MSHA guidelines to evaluate CCW impoundments. AMEC followed the guidelines presented in our scope of work for assessment of CCW impoundments which was provided by EPA.

AMEC acknowledges the stability studies performed for Ash Treatment Basin #2 indicate the impoundment meets KDOW requirements. AMEC recommends the seep identified at boring B-1.75T be monitored frequently until the time of, and, following repairs. AMEC recommends Kentucky Utilities evaluate the need to revise the stability analyses for Ash Treatment Basin #2 resulting from any changes made to improve the hydraulics of the facility as described in the previous section.

### **4.3.3 Monitoring and Instrumentation Recommendations**

#### September 2010 Draft Report

Twelve piezometers, of which 10 are remaining, were installed in 2010 (July and August) to support the recent stability analyses. It would be prudent for the Green River Power Station to maintain and protect these instruments, and document monitoring frequently until base line phreatic readings are apparent. After that time, a regular frequency should be maintained and the results evaluated by an engineer. Monitoring should include pond and river levels and should include additional readings and evaluation in response to elevated pond levels or specific rainfall events. AMEC recommends additional instrumentation, especially at the crest and toe of critical slopes, be installed as budgets or development of any future problems allow.

#### Final Report

AMEC reiterates our recommendations noted in the Draft report, especially to include pond and river levels with the readings. Additional piezometer readings provided by KU in their comments to the draft report indicate rising and falling water levels in B-2C and relatively static water levels in B-3C and B-4C. Without pond and river levels, no further evaluations can be made.



#### 4.3.4 Inspection Recommendations

##### September 2010 Draft Report

AMEC has reviewed provided information and inspection records for the Green River Ash Ponds: Ash Treatment Basin #1, Ash Treatment Basin #2, Scrubber Pond and Coal Runoff Pond and determined that Kentucky Utilities has begun adequate inspection practices. Finishing Pond #3 was removed from service in 2010, and therefore, no inspection services have been provided for this pond. AMEC recommends that the current inspection program by the plant be expanded to include at least monthly instrumentation monitoring and pond and river levels.

AMEC has reviewed the 2009 inspection reports and determined Kentucky Utilities has adequate annual inspections by a Profession Engineer. We recommend this type of annual inspection program and report by a Professional Engineer be continued at least yearly, in addition to the inspections by facility personnel. Due to the recent slide repair on the south dike of Ash Treatment Basin #1 and the Coal Runoff Pond, the recent surficial slide repair at the southwest corner of the Scrubber Pond and recent repair of the east dike of Ash Treatment Basin #2, AMEC recommends additional inspections be performed by Professional Engineer should any problems, such as seepage, scarps, etc., be encountered with the repairs or if new similar problems develop.

##### Final Report

The January 2011 inspection by ATC for Ash Treatment Basin #2 generally identified normal maintenance type items. KU's response to the Draft report stated they are developing plans to address the priority maintenance items in 2011. AMEC recommends KU perform frequent inspections of the south embankment with special attention to the seep area identified at B-1.75T.

#### 4.4 Scrubber Pond

##### 4.4.1 Hydrologic and Hydraulic Recommendations

##### September 2010 Draft Report

An August 2010 report by MACTEC Engineering and Consulting, Inc. titled *Assessment of Spillway Hydrologic Adequacy for the Coal Pile Pond, Ash Treatment Basin No. 2, and Scrubber Pond at Green River Generating Station* provides a hydrologic analysis that is specific to Ash Treatment Basin 2. Design storm events of various returns periods and of various durations, including 6 hours, 24 hours and 48 hours, were used in the analyses. The analyses for the Scrubber Pond indicated a minimum freeboard of 0.22 feet for the DNREP-DOW Class A freeboard design hydrograph (FDH) and a freeboard of 0.60 feet for the 100-year, 48-hour design storm event.

AMEC recommends that an appropriately conservative design storm rainfall and freeboard depth in accordance with MSHA guidelines be applied to the impoundment,s watershed to assure that the dam and decant system can safely store, control, and discharge the design flow. Based on the small size and significant rating for the Scrubber Pond, the MSHA design storm would be the ½ PMF. Hydraulic calculations should also be completed to determine the rate at which the discharge structure and associated piping could pass the design storm, if necessary, or draw down elevated water surfaces following such an event. The study should consider all

critical stages over the life of the pond including pond full conditions. MSHA guidelines recommend a minimum freeboard of 3 feet.

### Final Report

In comments included in the January 26, 2011 response to the Draft report by Kentucky Utilities and comments from Kentucky Department of Water to EPA dated January 31, 2011 both parties take exception to the use of MSHA guidelines to evaluate CCW impoundments. AMEC followed the guidelines presented in our scope of work for assessment of CCW impoundments which was provided by EPA.

MACTEC's *Addendum A* (January 25, 2011) to their August 12, 2010 report entitled *Assessment of Spillway Hydrologic Adequacy for the Coal Pile Pond, Ash Treatment Basin No. 2, and Scrubber Pond at Green River Generating Station* details modifications and improvements made to the Scrubber Pond pumping capacity in addition to the introduction of automation. AMEC acknowledges the hydraulic studies for the Scrubber Pond indicate the impoundment meets KDOW requirements. MSHA guidelines (rare or extreme hydrologic conditions) are not met, but the level of protection for the river, as well as the retention capacity of the impoundment, are greatly improved over previous conditions.

#### **4.4.2 Geotechnical and Stability Recommendations**

##### September 2010 Draft Report

In the opinion of the assessing professional engineer, the criteria for minimum safety factors should be in accordance with USACE EM 1110-2-1902 with a minimum seismic safety factor of 1.2 as recommended by 2007 *MSHA Coal Mine Impoundment Inspection and Plan Review Handbook*, page 88. Likewise, if the dam does not meet the above seismic factor of safety, then the stability of the embankment should be analyzed and the amount of embankment deformation or settlement that may occur should be evaluated to assure that sufficient section of the crest will remain intact to prevent a release from the impoundment.

A September 2010 report by MACTEC Engineering and Consulting, Inc. titled *Geotechnical Exploration and Slope Stability Analyses Data Package*, for the Green River Power Station presents stability analyses for Ash Treatment Basin #2 and the Scrubber Pond. Five sections were chosen for analyses on each structure. Section 1 is located on the south embankment of the Coal Runoff Pond. Sections 2 through 5 are located at Ash Treatment Basin #2 on the south embankment (2), southeast corner (3) and east embankment (4 and 5). Sections 6 through 10 are located at the Scrubber Pond on the west embankment (6), south embankment (7 and 8), southeast corner (9) and east embankment (10). For this preliminary report, results for sections 4 and 7 were presented.

Section 7 is located on the west end of the south embankment of the Scrubber Pond. This section is near a recently repaired surface area on the downstream embankment (located to the west). On first glance of the section reported, it appears from the plan sheet that Section 8 would have a steeper downstream slope and would be more critical. During the site visit, wet conditions were noted below the toe of the south embankment. Given this section may not represent the critical section, further review will not be performed at this time but rather at the completion of the study when recommendations herein have been incorporated into the analyses. Recommendations mentioned in the previous sections such as the configuration of

the slope and adjustment of soil strength parameters and a detailed discussion of the methods and parameters should be included in the final report.

The analysis should consider all critical stages over the life of the pond including pond full conditions. These conditions would need to be determined in conjunction with the hydraulic recommendations above. The hydraulic analysis should provide a phreatic surface through the embankment. A rapid-drawdown should be performed for upstream embankment in case the pond would need to be lowered in response to a problem, and the downstream embankment in relation to flooding of Green River. The friction angle value used for the CCW in the analysis appears high for ash material. Typical ash friction values are 28 degrees for compacted, 24 degrees for loosely compacted, and 11 degrees for uncompacted material. Consideration should be given for lowering strength values to account for inconsistencies within the fill or foundation materials. Consideration should also be given to allowing some time for water levels in the piezometers to develop and stabilize. The analyses presented appear limited to a circular surface; different types of failure surfaces should be analyzed and optimized.

In the opinion of the assessing professional engineer, the analyses should be revised in accordance with these recommendations. The analysis should consider all critical stages over the life of the pond including pond full conditions. These conditions would need to be determined in conjunction with the hydrologic and hydraulic recommendations above. The hydrologic and hydraulic analysis will provide maximum water levels in the pond and a phreatic surface through the embankment.

#### Final Report

In comments included in the January 26, 2011 response to the Draft report by Kentucky Utilities and comments from Kentucky Department of Water to EPA dated January 31, 2011 both parties take exception to the use of MSHA guidelines to evaluate CCW impoundments. AMEC followed the guidelines presented in our scope of work for assessment of CCW impoundments which was provided by EPA.

AMEC acknowledges the stability studies performed for the Scrubber Pond indicate the impoundment meets KDOW requirements. AMEC recommends restoration of the interior slopes and crest, and frequent monitoring of the relatively steep downstream slopes and wet area below the south embankment for any signs of distress.

#### **4.4.3 Monitoring and Instrumentation Recommendations**

##### September 2010 Draft Report

Twelve piezometers, of which 10 are remaining, were installed in 2010 (July and August) to support the recent stability analyses. It would be prudent for the Green River Power Station to maintain and protect these instruments, and document monitoring frequently until base line phreatic readings are apparent. After that time, a regular frequency should be maintained and the results evaluated by an engineer. Monitoring should include pond and river levels and should include additional readings and evaluation in response to elevated pond levels or specific rainfall events. AMEC recommends additional instrumentation, especially at the crest and toe of critical slopes, be installed as budgets or development of any future problems allow.

### Final Report

AMEC reiterates our recommendations noted in the Draft report, especially to include pond and river levels with the readings. Additional piezometer readings provided by KU in their comments to the draft report indicate relatively static water levels in B-6C, rising to static levels in B-8C and rising levels in B-10C. Without pond and river levels, no further evaluations can be made. AMEC recommends KU evaluate the need to install piezometer(s) below the south embankment.

#### **4.4.4 Inspection Recommendations**

##### September 2010 Draft Report

AMEC has reviewed provided information and inspection records for the Green River Ash Ponds: Ash Treatment Basin #1, Ash Treatment Basin #2, Scrubber Pond and Coal Runoff Pond and determined that Kentucky Utilities has begun adequate inspection practices. Finishing Pond #3 was removed from service in 2010, and therefore, no inspection services have been provided for this pond. AMEC recommends that the current inspection program by the plant be expanded to include at least monthly instrumentation monitoring and pond and river levels.

AMEC has reviewed the 2009 inspection reports and determined KENTUCKY UTILITIES has adequate annual inspections by a Profession Engineer. We recommend this type of annual inspection program and report by a Professional Engineer be continued at least yearly, in addition to the inspections by facility personnel. Due to the recent slide repair on the south dike of Ash Treatment Basin #1 and the Coal Runoff Pond, the recent surficial slide repair at the southwest corner of the Scrubber Pond and recent repair of the east dike of Ash Treatment Basin #2, AMEC recommends additional inspections be performed by Professional Engineer should any problems, such as seepage, scarps, etc., be encountered with the repairs or if new similar problems develop.

##### Final Report

The January 2011 inspection by ATC for the Scrubber Pond generally identified normal maintenance type items. KU's response to the Draft report stated they are developing plans to address the priority maintenance items in 2011. AMEC recommend KU perform frequent inspections of the embankments and wet area below the south embankment.

#### **4.5 Former Ash Pond or Coal Runoff Pond**

##### **4.5.1 Hydrologic and Hydraulic Recommendations**

##### September 2010 Draft Report

An August 2010 report by MACTEC Engineering and Consulting, Inc. titled *Assessment of Spillway Hydrologic Adequacy for the Coal Pile Pond, Ash Treatment Basin No. 2, and Scrubber Pond at Green River Generating Station* provides a hydrologic analysis that is specific to Ash Treatment Basin 2. Design storm events of various returns periods and of various durations, including 6 hours, 24 hours and 48 hours, were used in the analyses. The analyses for the Coal Runoff Pond indicated a minimum freeboard of 1.74 feet for the DNREP-DOW Class A freeboard design hydrograph (FDH) and a freeboard of 2.17 feet for the 100-year, 48-hour design storm event.

AMEC recommends that an appropriately conservative design storm rainfall and freeboard depth in accordance with MSHA guidelines be applied to the impoundment,s watershed to assure that the dam and decant system can safely store, control, and discharge the design flow. Based on the small size and significant rating for the Scrubber Pond, the MSHA design storm would be the ½ PMF. Hydraulic calculations should also be completed to determine the rate at which the discharge structure and associated piping could pass the design storm, if necessary, or draw down elevated water surfaces following such an event. The study should consider all critical stages over the life of the pond including pond full conditions. MSHA guidelines recommend a minimum freeboard of 3 feet.

### Final Report

In comments included in the January 26, 2011 response to the Draft report by Kentucky Utilities and comments from Kentucky Department of Water to EPA dated January 31, 2011 both parties take exception to the use of MSHA guidelines to evaluate CCW impoundments. AMEC followed the guidelines presented in our scope of work for assessment of CCW impoundments which was provided by EPA.

MACTEC's Addendum A (January 25, 2011) to their August 12, 2010 report entitled Assessment of Spillway Hydrologic Adequacy for the Coal Pile Pond, Ash Treatment Basin No. 2, and Scrubber Pond at Green River Generating Station details an increase of the dam crest of the Coal Pile Runoff Pond by 0.5 feet to elevation 405.5 ft NAVD88. MSHA guidelines (rare or extreme hydrologic conditions) are not met, but the level of protection for the river, as well as the retention capacity of the impoundment, are greatly improved over previous conditions.

## **4.5.2 Geotechnical and Stability Recommendations**

### September 2010 Draft Report

In the opinion of the assessing professional engineer, the criteria for minimum safety factors should be in accordance with USACE EM 1110-2-1902 with a minimum seismic safety factor of 1.2 as recommended by 2007 *MSHA Coal Mine Impoundment Inspection and Plan Review Handbook*, page 88. Likewise, if the dam does not meet the above seismic factor of safety, then the stability of the embankment should be analyzed and the amount of embankment deformation or settlement that may occur should be evaluated to assure that sufficient section of the crest will remain intact to prevent a release from the impoundment.

A September 2010 report by MACTEC Engineering and Consulting, Inc. titled *Geotechnical Exploration and Slope Stability Analyses Data Package*, for the Green River Power Station presents stability analyses for Ash Treatment Basin #2 and the Scrubber Pond. Five sections were chosen for analyses on each structure. Section 1 is located on the south embankment of the Coal Runoff Pond. Sections 2 through 5 are located at Ash Treatment Basin #2 on the south embankment (2), southeast corner (3) and east embankment (4 and 5). Sections 6 through 10 are located at the Scrubber Pond on the west embankment (6), south embankment (7 and 8), southeast corner (9) and east embankment (10). For this preliminary report, results for sections 4 and 7 were presented.

Section 1 is located on the south embankment of the Coal Runoff Pond. The 2009 ATC inspection report mentions needed repairs for a surface failure on the downstream slope in this area. During our site visit, the toe and the area below the downstream slope had been recently repaired. Details of the repair were not provided. The analysis for this section was not

provided in the preliminary report. The results of the analyses should be reviewed when the final report is completed

The analysis should consider all critical stages over the life of the pond including pond full conditions. These conditions would need to be determined in conjunction with the hydraulic recommendations above. The hydraulic analysis should provide a phreatic surface through the embankment. A rapid-drawdown should be performed for upstream embankment in case the pond would need to be lowered in response to a problem, and the downstream embankment in relation to flooding of Green River. The friction angle value used for the CCW in the analysis appears high for ash material. Typical ash friction values are 28 degrees for compacted, 24 degrees for loosely compacted, and 11 degrees for uncompacted material. Consideration should be given for lowering strength values to account for inconsistencies within the fill or foundation materials. Consideration should also be given to allowing some time for water levels in the piezometers to develop and stabilize. The analyses presented appear limited to a circular surface; different types of failure surfaces should be analyzed and optimized.

In the opinion of the assessing professional engineer, the analyses should be performed in accordance with these recommendations. The analysis should consider all critical stages over the life of the pond including pond full conditions. These conditions would need to be determined in conjunction with the hydrologic and hydraulic recommendations above. The hydrologic and hydraulic analysis will provide maximum water levels in the pond and a phreatic surface through the embankment.

#### Final Report

In comments included in the January 26, 2011 response to the Draft report by Kentucky Utilities and comments from Kentucky Department of Water to EPA dated January 31, 2011 both parties take exception to the use of MSHA guidelines to evaluate CCW impoundments. AMEC followed the guidelines presented in our scope of work for assessment of CCW impoundments which was provided by EPA.

The results of stability studies performed for the Coal Runoff Pond indicate the downstream embankment does not meet applicable requirements for the long term/maximum surcharge pool and long term/maximum surcharge pool/maximum solids (pond full) conditions. The January Final Stability Report and Addendum A to this report note "methods are available for improving the minimum factor of safety such as installation of a rock buttress on the downstream slope to provide more sliding resistance along the predicted slip circle". In their comments to the draft report KU states they are "currently evaluating the results and plan to study options to improve the section if necessary to increase the factor of safety above KY DEP recommended values". AMEC recommends KU continue their ongoing evaluation and develop plans to improve the stability of the south embankment to meet applicable minimum safety requirements.

#### **4.5.3 Monitoring and Instrumentation Recommendations**

##### September 2010 Draft Report

Twelve piezometers, of which 10 are remaining, were installed in 2010 (July and August) to support the recent stability analyses. It would be prudent for the Green River Power Station to maintain and protect these instruments, and document monitoring frequently until base line phreatic readings are apparent. After that time, a regular frequency should be maintained and the results evaluated by an engineer. Monitoring should include pond and river levels and

should include additional readings and evaluation in response to elevated pond levels or specific rainfall events. AMEC recommends additional instrumentation, especially at the crest and toe of critical slopes, be installed as budgets or development of any future problems allow.

#### Final Report

AMEC reiterates our recommendations noted in the Draft report, especially to include pond and river levels with the readings. Additional piezometer readings provided by KU in their comments to the Draft report indicate rising and falling water levels in B-2C located to the east of the pond. A recent surface slope repair was reported on the south embankment and inspection reports note a seep at Boring B-1.75T located to the east of the coal Pile Runoff Pond. AMEC recommends KU evaluate the need to install piezometer(s) at the crest and below the south embankment of the Coal Pile Runoff Pond.

#### **4.5.4 Inspection Recommendations**

##### September 2010 Draft Report

AMEC has reviewed provided information and inspection records for the Green River Ash Ponds: Ash Treatment Basin #1, Ash Treatment Basin #2, Scrubber Pond and Coal Runoff Pond and determined that Kentucky Utilities has begun adequate inspection practices. Finishing Pond #3 was removed from service in 2010, and therefore, no inspection services have been provided for this pond. AMEC recommends that the current inspection program by the plant be expanded to include at least monthly instrumentation monitoring and pond and river levels.

AMEC has reviewed the 2009 inspection reports and determined KU has adequate annual inspections by a Profession Engineer. We recommend this type of annual inspection program and report by a Professional Engineer be continued at least yearly, in addition to the inspections by facility personnel. Due to the recent slide repair on the south dike of Ash Treatment Basin #1 and the Coal Runoff Pond, the recent surficial slide repair at the southwest corner of the Scrubber Pond and recent repair of the east dike of Ash Treatment Basin #2, AMEC recommends additional inspections be performed by Professional Engineer should any problems, such as seepage, scarps, etc., be encountered with the repairs or if new similar problems develop.

##### Final Report

The January 2011 inspection by ATC for the Coal Pile Runoff Pond generally identified normal maintenance type items. KU's response to the draft report stated they are developing plans to address the priority maintenance items in 2011. AMEC recommends KU perform frequent inspections of the south embankment.

## 5.0 CLOSING

This report is prepared for the exclusive use of the Environmental Protection Agency for the site and criteria stipulated herein. This report does not address regulatory issues associated with storm water runoff, the identification and modification of regulated wetlands, or ground water recharge areas. Further, this report does not include review or analysis of environmental or regional geo-hydrologic aspects of the site, except as noted herein. Questions or interpretation regarding any portion of the report should be addressed directly by the geotechnical engineer.

Any use, reliance on, or decisions to be made based on this report by a third party are the responsibility of such third parties. AMEC accepts no responsibility for damages, if any, suffered by any third party as a result of decisions made or actions based on this report.

The conclusions and recommendations given in this report are based on visual observations, our partial knowledge of the history of Green River Power Station impoundments, and information provided to us by others. This report has been prepared in accordance with normally accepted geotechnical engineering practices. No other warranty is expressed or implied.



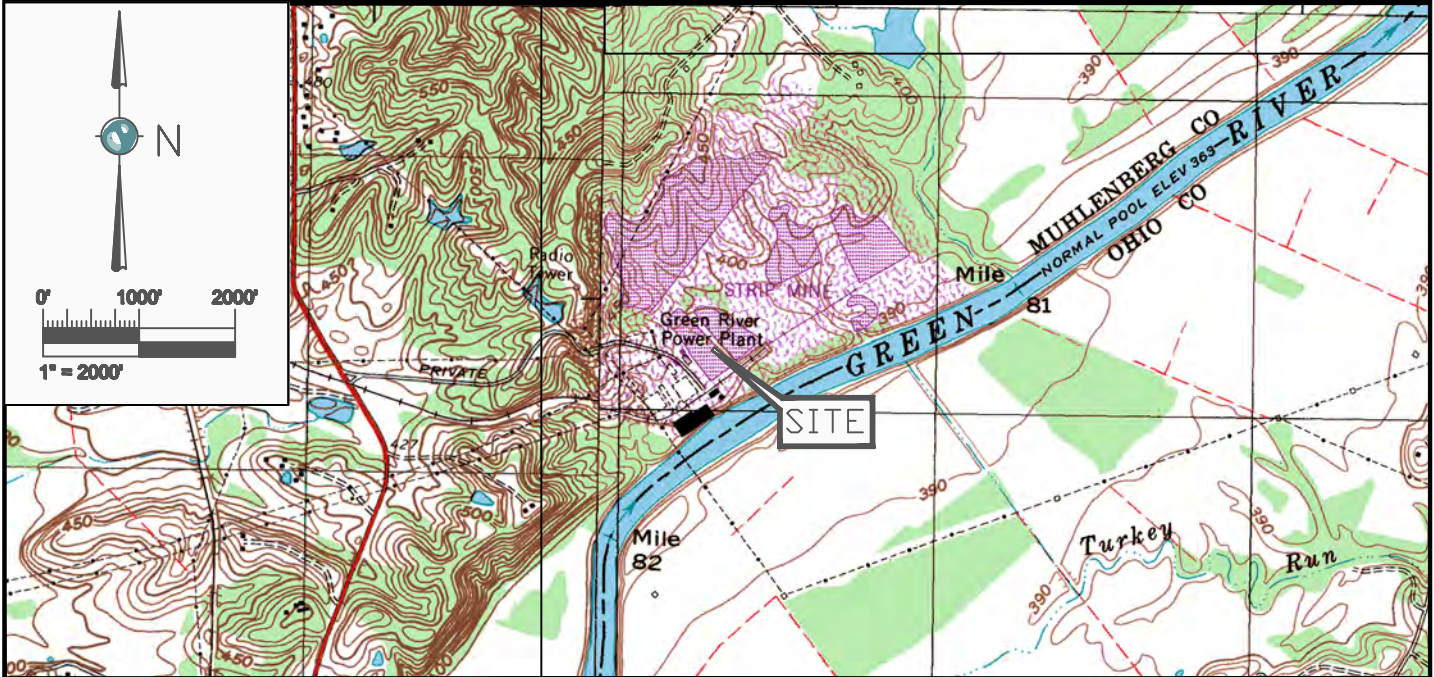
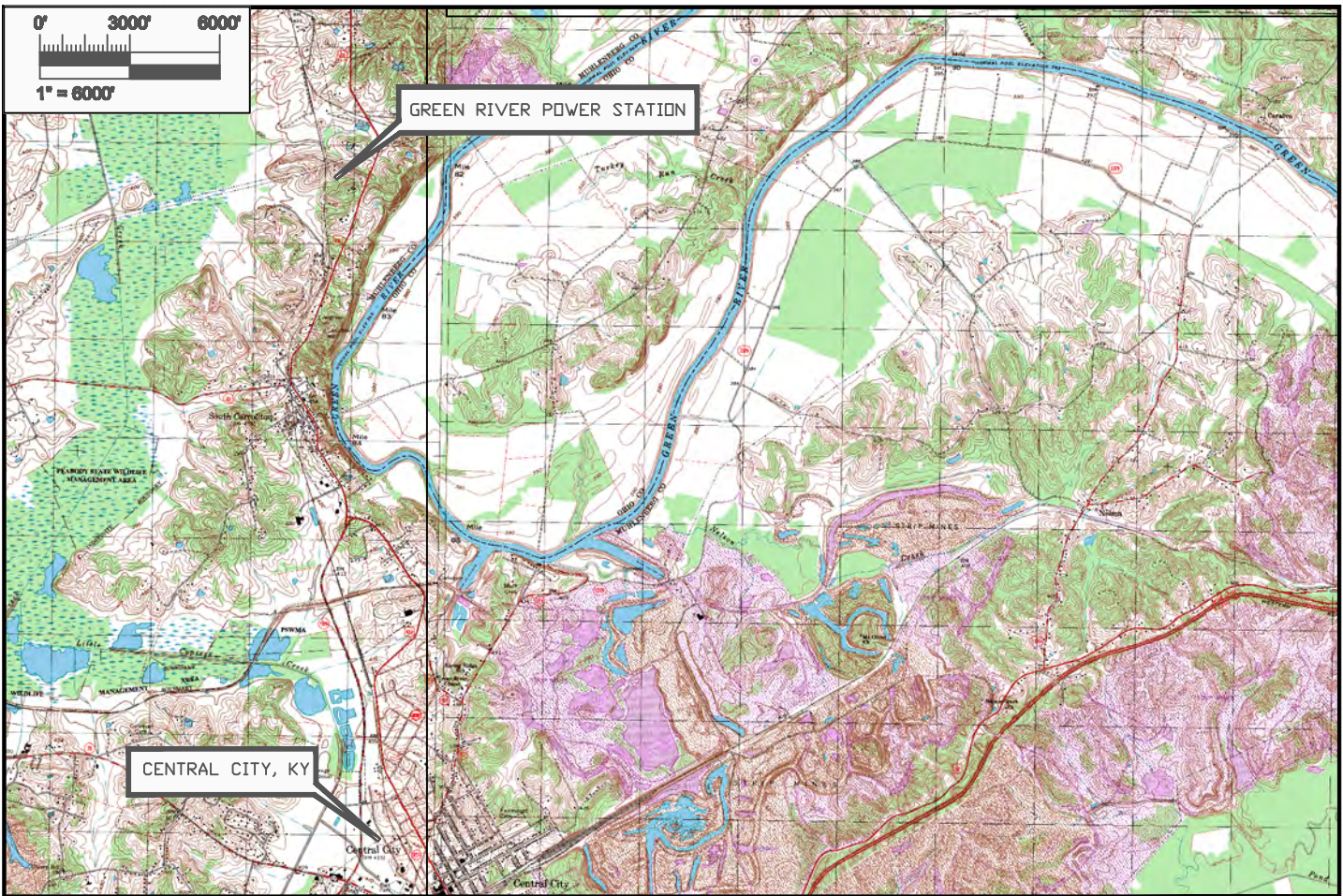

<b>AMEC Earth &amp; Environmental</b> 690 Commonwealth Center 11003 Bluegrass Parkway Louisville, Ky 40239 (502) 267-0700				<b>CLIENT LOGO</b> 		<b>CLIENT</b> UNITED STATES ENVIRONMENTAL PROTECTION AGENCY			
<b>PROJECT</b> ASSESSMENT OF DAM SAFETY OF COAL COMBUSTION SURFACE IMPOUNDMENTS				<b>DWN BY:</b> CAE		<b>DATUM:</b>		<b>DATE:</b> 9/13/10	
<b>TITLE</b> KENTUCKY UTILITIES, SUBSIDIARY OF E.ON U.S. GREEN RIVER POWER STATION, CENTRAL CITY, KY SITE LOCATION & VICINITY MAP				<b>CHK'D BY:</b> MSC		<b>REV. NO.:</b>		<b>PROJECT NO:</b> 3-2108-0177-0003	
				<b>PROJECTION:</b>		<b>SCALE:</b> AS SHOWN		<b>FIGURE No.</b> 1	

ASH TREATMENT BASIN #1  
MAIN ASH POND

ASH TREATMENT  
BASIN #2

SCRUBBER  
POND

FINISHING POND  
# 3

COAL PILE RUNOFF POND

POWER PLANT DR

GREEN RIVER

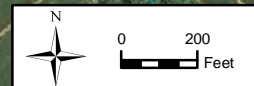

UNITED STATES  
ENVIRONMENTAL PROTECTION AGENCY

DWN BY: DJC

CKD BY: MS

Datum: NAD 83

Projection: Albers

Scale: As Shown

ASSESSMENT OF DAM SAFETY OF  
COAL COMBUSTION SURFACE IMPOUNDMENTS

REV. No.: A

Date: 9-14-10

Project No: 3-2106-0177-0002

Figure No: 2

AMEC Earth & Environmental  
690 Commonwealth Business Center  
11003 Bluegrass Parkway  
Louisville, KY 40299



GREEN RIVER POWER STATION  
CENTRAL CITY, KY  
SITE PLAN



Critical Infrastructure	ID	Longitude	Latitude
Equality Church	1	-87.072773	37.393101
Oak Grove Church	2	-87.076385	37.419768
Smallhouse Church	3	-87.082774	37.384489



Green River Flow Direction

Green River Power Plant

**Legend**

-  Church
-  Railroad



AMEC Earth & Environmental  
690 Commonwealth Business Center  
11003 Bluegrass Parkway  
Louisville, KY 40299

UNITED STATES  
ENVIRONMENTAL PROTECTION AGENCY



DRAWN BY: DJC  
CHKD BY: MS  
DATUM: NAD83  
PROJECTION: Albers  
SCALE: AS SHOWN  
DATE: 5/21/2010

ASSESSMENT OF DAM SAFETY OF  
COAL COMBUSTION SURFACE IMPOUNDMENTS

KENTUCKY UTILITIES  
GREEN RIVER POWER STATION, CENTRAL CITY, KY  
CRITICAL INFRASTRUCTURE

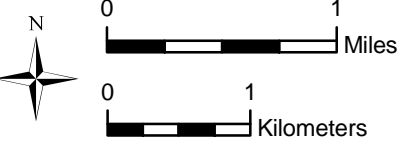

0 1 Miles  
0 1 Kilometers

Notes: Critical infrastructure data provided by ESRI

**FIGURE 3**

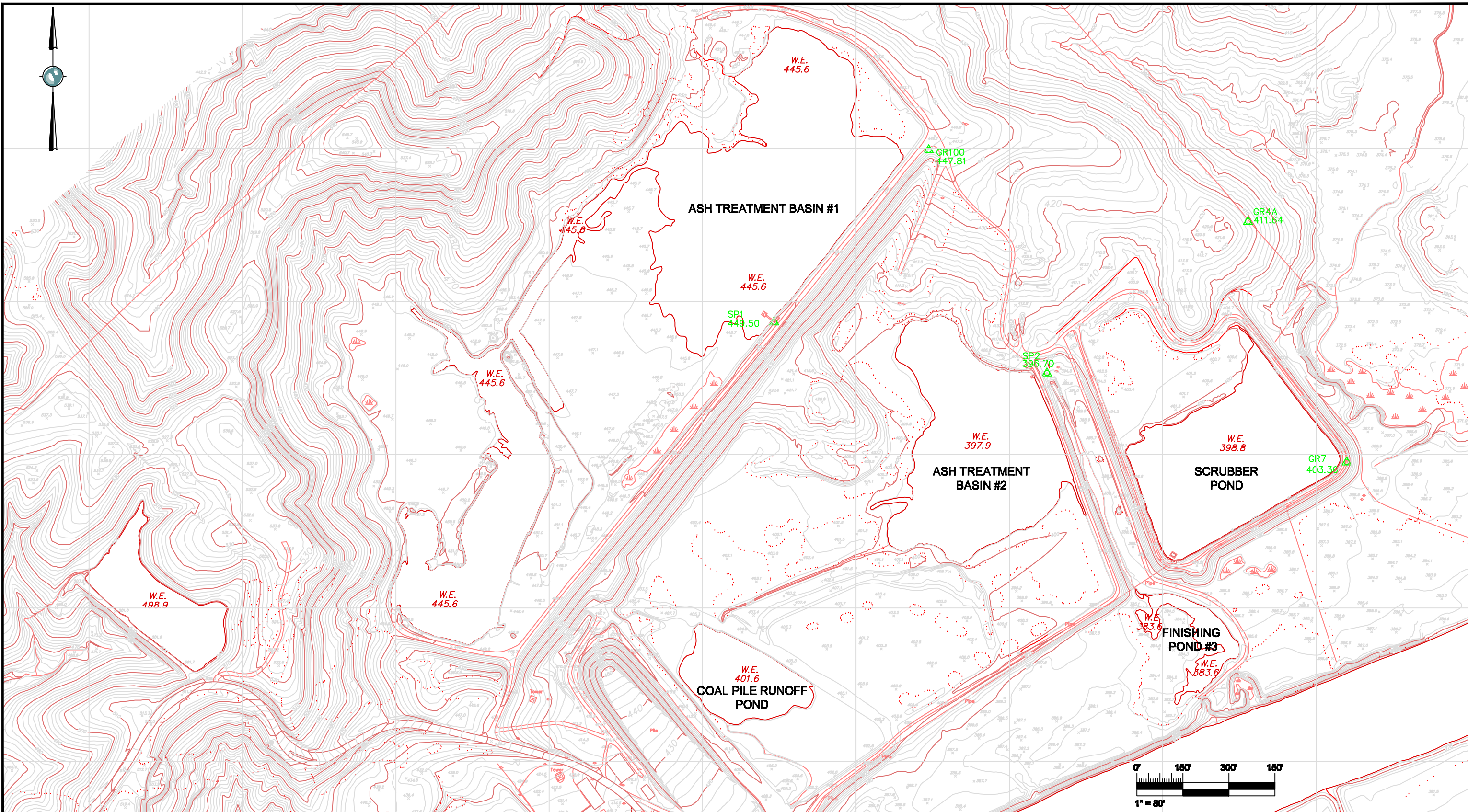

NOTE: THIS DRAWING SHOULD BE READ IN CONJUNCTION WITH THE AMEC EARTH & ENVIRONMENTAL REPORT



CLIENT: **UNITED STATES ENVIRONMENTAL PROTECTION AGENCY**

**AMEC Earth & Environmental**  
 690 Commonwealth Center  
 11003 Bluegrass Parkway  
 Louisville, Ky 40299  
 (502) 267-0700

DWN BY: CAE  
 CHK'D BY: MSC  
 DATUM:  
 PROJECTION:  
 SCALE: AS SHOWN

PROJECT: **ASSESSMENT OF DAM SAFETY OF COAL COMBUSTION SURFACE IMPOUNDMENTS**

TITLE: **KENTUCKY UTILITIES, SUBSIDIARY OF E.ON U.S. GREEN RIVER POWER STATION, CENTRAL CITY, KY SITE TOPOGRAPHIC MAP**

DATE: 9/14/10  
 PROJECT NO: 3-2106-0177-0003  
 REV. NO.:  
 FIGURE No. 4

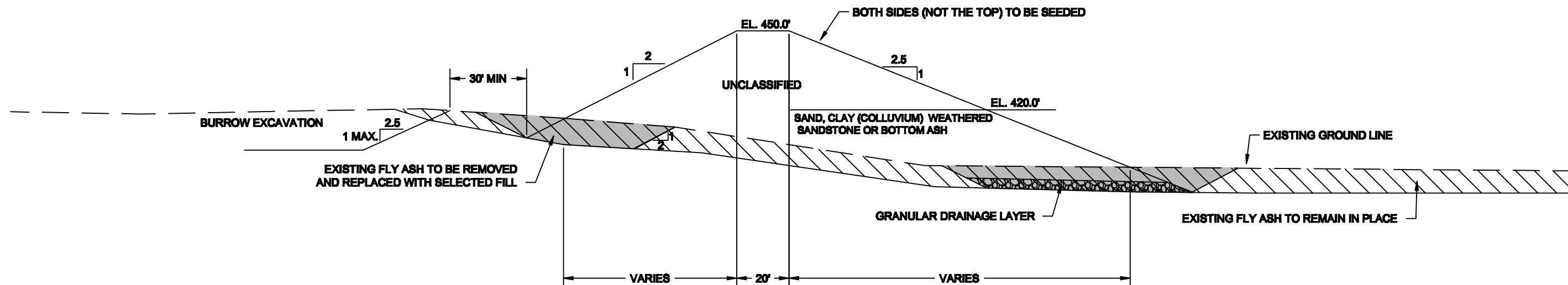
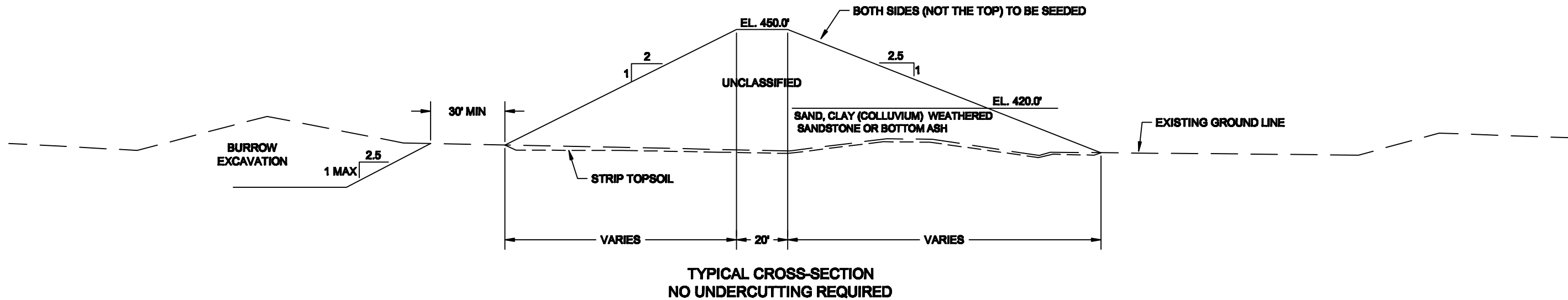

NOTE: THIS DRAWING SHOULD BE READ IN CONJUNCTION WITH THE AMEC EARTH & ENVIRONMENTAL REPORT

CLIENT LOGO



CLIENT:

**UNITED STATES ENVIRONMENTAL PROTECTION AGENCY**

**AMEC Earth & Environmental**

690 Commonwealth Center  
11003 Bluegrass Parkway  
Louisville, Ky 40299  
(502) 267-0700



DWN BY:

CAE

CHKD BY:

MSC

DATUM:

PROJECTION:

SCALE:

AS SHOWN

PROJECT

**ASSESSMENT OF DAM SAFETY OF COAL COMBUSTION SURFACE IMPOUNDMENTS**

TITLE

**KENTUCKY UTILITIES, SUBSIDIARY OF E.ON U.S.  
GREEN RIVER POWER STATION, CENTRAL CITY, KY  
ASH TREATMENT BASIN #1 TYPICAL CROSS SECTIONS**

DATE:

9/14/10

PROJECT NO.:

3-2106-0177-0003

REV. NO.:

FIGURE No.

5

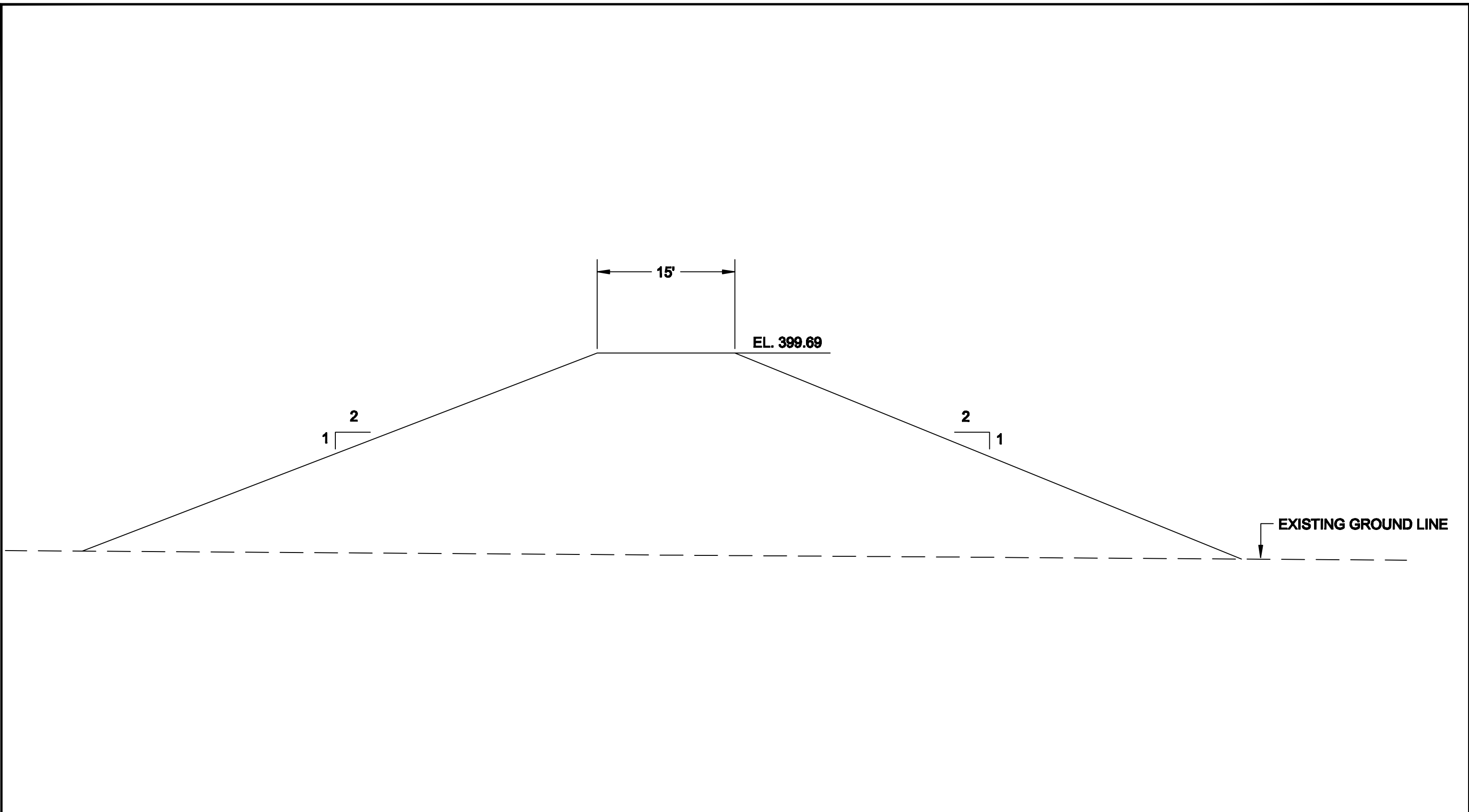

NOTE: THIS DRAWING SHOULD BE READ IN CONJUNCTION WITH THE AMEC EARTH & ENVIRONMENTAL REPORT



CLIENT: UNITED STATES ENVIRONMENTAL PROTECTION AGENCY

**AMEC Earth & Environmental**  
 690 Commonwealth Center  
 11003 Bluegrass Parkway  
 Louisville, Ky 40299  
 (502) 267-0700



DWN BY: CAE  
 CHK'D BY: MSC  
 DATUM:  
 PROJECTION:  
 SCALE: NTS

PROJECT **ASSESSMENT OF DAM SAFETY OF COAL COMBUSTION SURFACE IMPOUNDMENTS**

TITLE **KENTUCKY UTILITIES, SUBSIDIARY OF E.ON U.S. GREEN RIVER POWER STATION, CENTRAL CITY, KY COAL PILE RUN OFF POND CROSS-SECTION**

DATE: 9/14/10

PROJECT NO: 3-2106-0177-0003

REV. NO.:

FIGURE No. 6

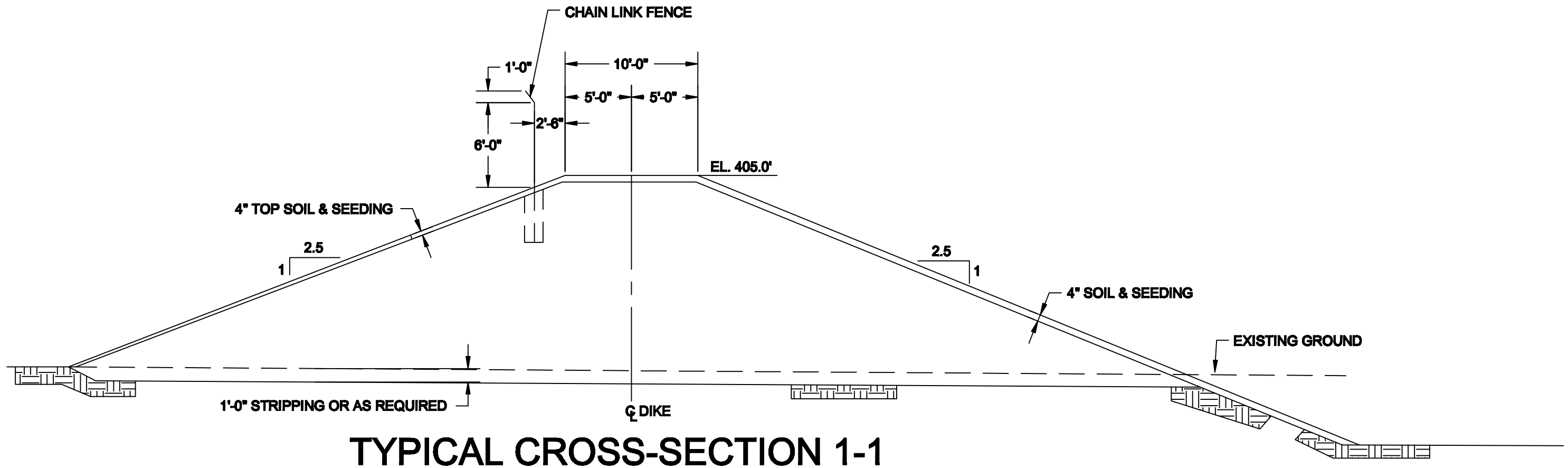

**TYPICAL CROSS-SECTION 1-1**

NOTE: THIS DRAWING SHOULD BE READ IN CONJUNCTION WITH THE AMEC EARTH & ENVIRONMENTAL REPORT

CLIENT LOGO



CLIENT:

**UNITED STATES ENVIRONMENTAL PROTECTION AGENCY**

**AMEC Earth & Environmental**

660 Commonwealth Center  
11003 Bluegrass Parkway  
Louisville, Ky 40299  
(502) 287-0700



DWN BY:

CAE

CHKD BY:

MBC

DATUM:

PROJECTION:

SCALE:

NTS

PROJECT

**ASSESSMENT OF DAM SAFETY OF COAL COMBUSTION SURFACE IMPOUNDMENTS**

TITLE

**KENTUCKY UTILITIES, SUBSIDIARY OF E.ON U.S. GREEN RIVER POWER STATION, CENTRAL CITY, KY SCRUBBER POND CROSS-SECTION**

DATE:

8/14/10

PROJECT NO:

3-2108-0177-0003

REV. NO.:

FIGURE No.

7

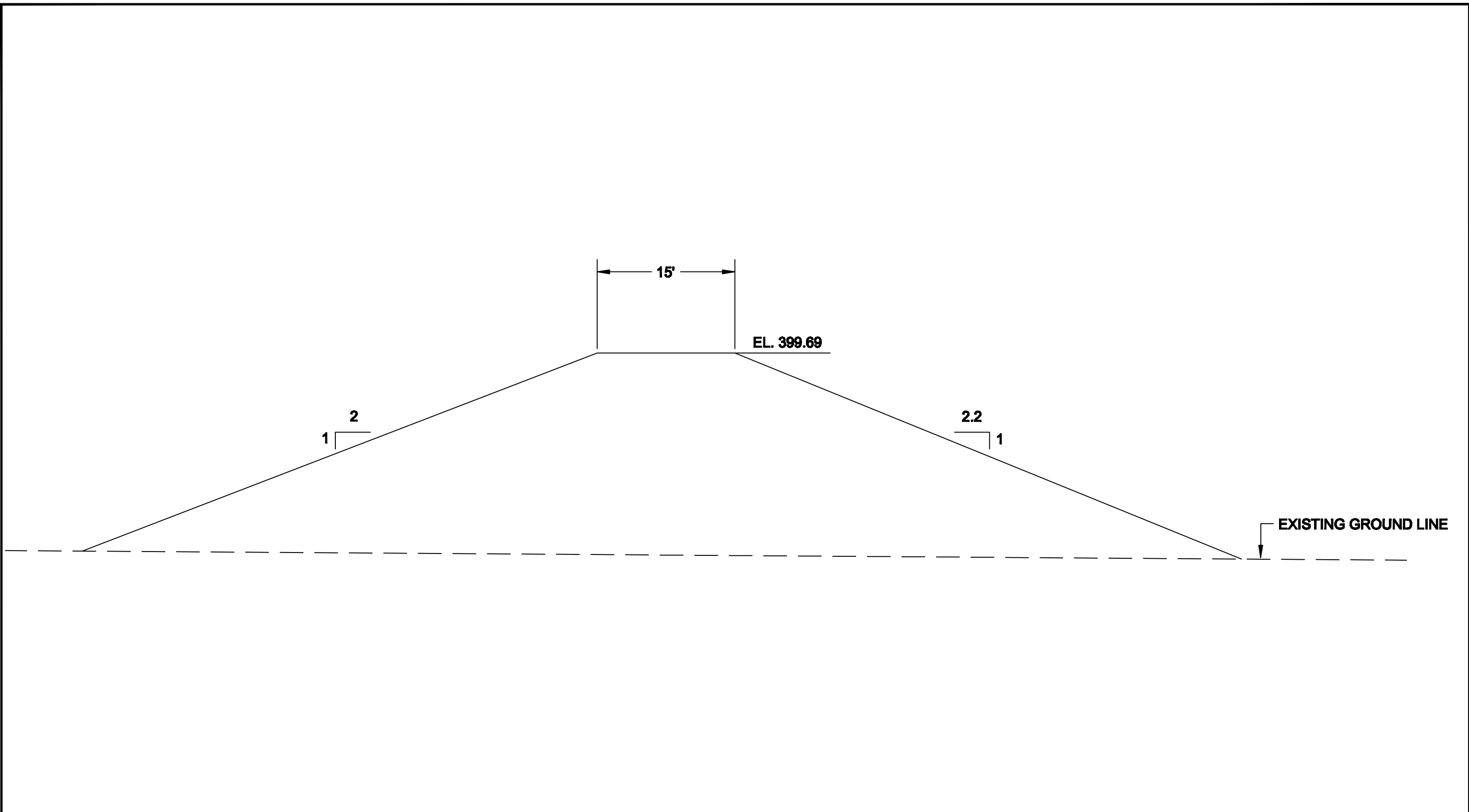

NOTE: THIS DRAWING SHOULD BE READ IN CONJUNCTION WITH THE AMEC EARTH & ENVIRONMENTAL REPORT



CLIENT: UNITED STATES ENVIRONMENTAL PROTECTION AGENCY

**AMEC Earth & Environmental**  
 690 Commonwealth Center  
 11003 Bluegrass Parkway  
 Louisville, Ky 40299  
 (502) 267-0700



DWN BY: CAE  
 CHK'D BY: MSC  
 DATUM:  
 PROJECTION:  
 SCALE: NTS

PROJECT **ASSESSMENT OF DAM SAFETY OF COAL COMBUSTION SURFACE IMPOUNDMENTS**

TITLE **KENTUCKY UTILITIES, SUBSIDIARY OF E.ON U.S. GREEN RIVER POWER STATION, CENTRAL CITY, KY COAL PILE RUN OFF POND CROSS-SECTION**

DATE: 9/14/10  
 PROJECT NO: 3-2106-0177-0003  
 REV. NO.:  
 FIGURE No. 8



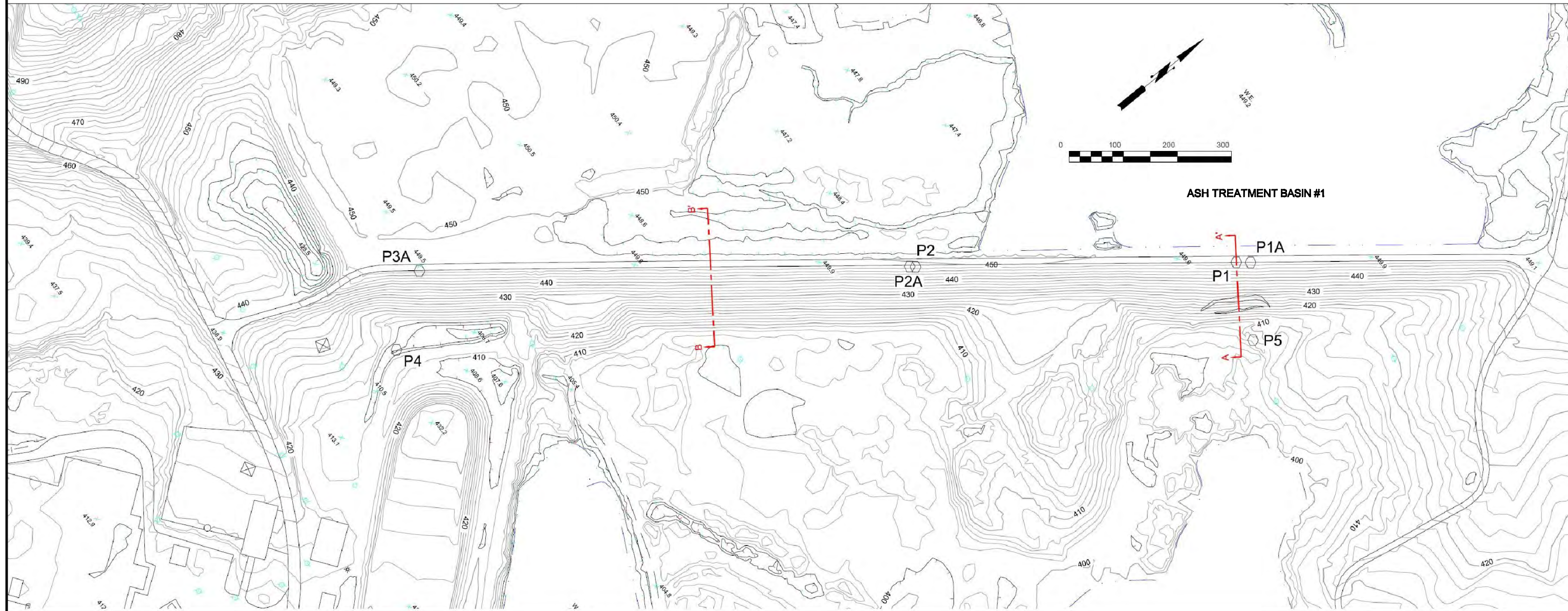

 P4 PIEZOMETER AND BORING LOCATIONS

NOTE: THIS DRAWING SHOULD BE READ IN CONJUNCTION WITH THE AMEC EARTH & ENVIRONMENTAL REPORT

CLIENT LOGO



CLIENT:

**UNITED STATES ENVIRONMENTAL PROTECTION AGENCY**

**AMEC Earth & Environmental**  
 690 Commonwealth Center  
 11003 Bluegrass Parkway  
 Louisville, Ky 40299  
 (502) 267-0700



DWN BY: CAE

CHK'D BY: MSC

DATUM:

PROJECTION:

SCALE: AS SHOWN

PROJECT **ASSESSMENT OF DAM SAFETY OF COAL COMBUSTION SURFACE IMPOUNDMENTS**

TITLE **KENTUCKY UTILITIES, SUBSIDIARY OF E.ON U.S. GREEN RIVER POWER STATION, CENTRAL CITY, KY ASH TREATMENT BASIN #1 BORING, PIEZOMETER, & CROSS SECTIONS LOCATIONS**

DATE: 8/14/10

PROJECT NO: 3-2106-0177-0003

REV. NO.:

FIGURE No. 9

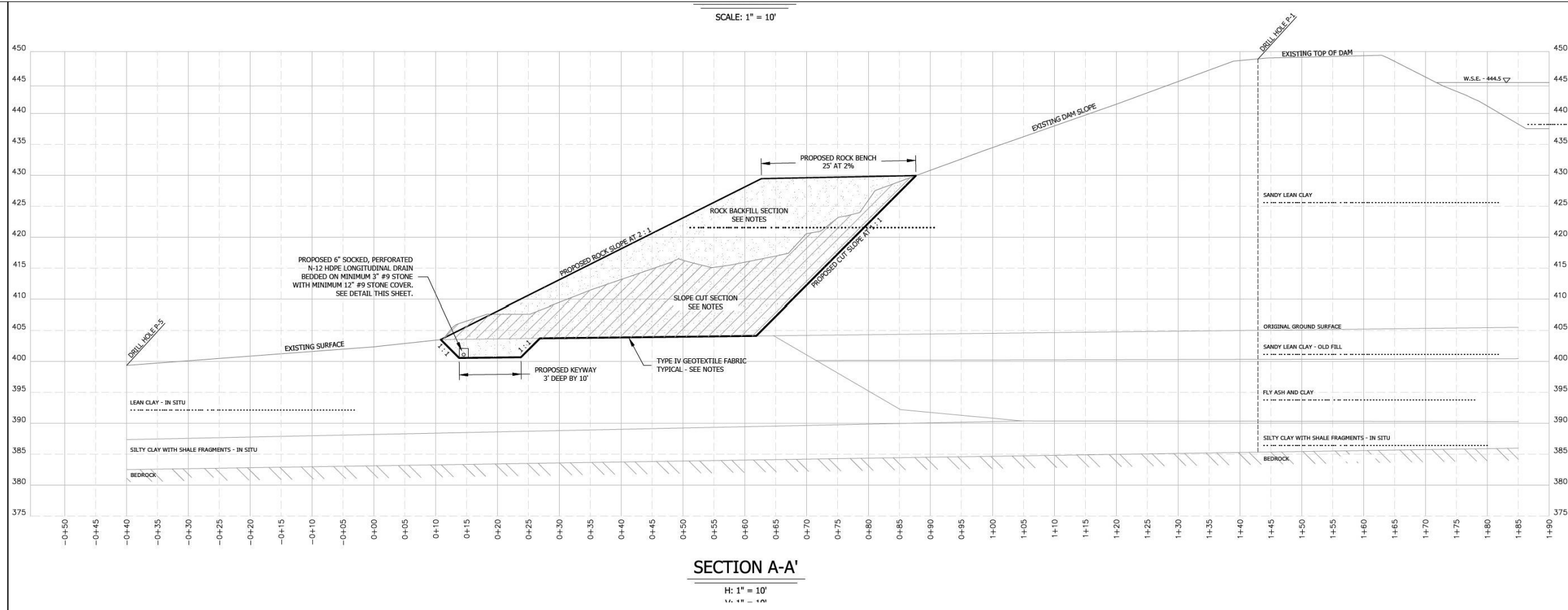

**NOTES:**

PLACE GEOTEXTILE FABRIC, TYPE IV ON EXCAVATED SOIL AREA MEETING THE REQUIREMENTS OF SECTION 843, TYPE IV, OF THE CURRENT EDITION OF KENTUCKY STANDARD SPECIFICATIONS FOR ROAD AND BRIDGE CONSTRUCTION. INSTALL GEOTEXTILE FABRIC ACCORDING TO SECTION 214 OF THE STANDARD SPECIFICATIONS FOR ROAD AND BRIDGE CONSTRUCTION. PREPARE THE SURFACE TO A SMOOTH CONDITION FREE OF OBSTRUCTIONS, DEBRIS, OR SHARP OBJECTS THAT MAY PUNCTURE THE FABRIC. PLACE THE FABRIC SMOOTH AND FREE OF TENSION, STRESS, FOLDS, WRINKLES, OR CREASES. DO NOT OPERATE EQUIPMENT DIRECTLY ON THE FABRIC. OVERLAP STRIPS AT LEAST 18 INCHES. PLACE TRANSVERSE LAPS SO THE UPSLOPE STRIP LAPS OVER THE DOWNSLOPE STRIP. INSTALL FASTENER PINS THROUGH BOTH STRIPS OF OVERLAP FABRIC AT NO LESS THAN 5-FOOT INTERVALS ALONG A LINE THROUGH THE MIDPOINT OF THE OVERLAP, AND AT ANY OTHER LOCATIONS AS NECESSARY TO PREVENT ANY SLIP OF THE FABRIC. PLACE FABRIC WITH THE LONG DIMENSION PARALLEL TO THE LONG DIMENSION OF THE SECTION TO BE COVERED.

USE KENTUCKY COARSE AGGREGATE NO. 2'S, 3'S, OR 23'S MEETING THE REQUIREMENTS OF SECTIONS 703 AND 805 OF THE STANDARD SPECIFICATIONS FOR ROAD AND BRIDGE CONSTRUCTION (CURRENT EDITION).

DO NOT STOCKPILE, EVEN TEMPORARILY, THE EXCAVATED MATERIAL ON ANY SLOPE OF THE DAM. DO NOT OPERATE OR PARK EQUIPMENT ON AREAS OF THE DAM OUTSIDE THE AREA TO BE EXCAVATED.

EXCAVATION OF THE FAILED MATERIAL WILL INVOLVE SOME RISK. TO PREVENT POTENTIAL DAMAGE TO UPSLOPE AREAS, PERFORM THE EXCAVATION IN SECTIONS LONGER THAN 40 FT AS MEASURED IN THE LONGITUDINAL DIRECTION AT THE BOTTOM OF THE SLOPE, AND BACKFILL WITH ROCK TO THE TOP OF THE EXCAVATION AS SOON AS POSSIBLE. SEQUENCE CONSTRUCTION AS SHOWN. COMPLETE THE BACK FILLING EACH 40 FT. SECTION WITHIN 24 HOURS AFTER BEGINNING EXCAVATION IN THAT SECTION.

MAINTAIN POSITIVE DRAINAGE AWAY FROM ALL AREAS AT TOE OF DAM.

**ESTIMATED MATERIAL QUANTITIES:**

**\*\*THE FOLLOWING QUANTITIES ARE PROVIDED AS ENGINEERING BUDGET ESTIMATES ONLY AND NOT FOR BID PURPOSES.\*\***

SOIL REMOVED FROM EXISTING DAM AND PROPOSED KEYWAY TOTALS APPROXIMATELY 3,500 CUBIC YARDS, OR 22 CUBIC YARDS PER FOOT OF REPAIR LENGTH (BASED FROM APPROXIMATE 157' OF REPAIR AREA SHOWN).

STONE BACKFILL TOTALS APPROXIMATELY 6,200 CUBIC YARDS OR 9,600 TONS AT 120 POUNDS PER CUBIC FOOT, OR 61 TONS PER FOOT OF REPAIR LENGTH (BASED FROM APPROXIMATE 157' OF REPAIR AREA SHOWN).

GEOTEXTILE FABRIC COVERAGE AREA APPROXIMATELY 17,500 SF - NOT ACCOUNTING FOR LAPPING OF FABRIC.

**SECTION A-A'**  
**CROSS-SECTION OF SLOPE FAILURE**

NOTE: THIS DRAWING SHOULD BE READ IN CONJUNCTION WITH THE AMEC EARTH & ENVIRONMENTAL REPORT



CLIENT: **UNITED STATES ENVIRONMENTAL PROTECTION AGENCY**

**AMEC Earth & Environmental**  
690 Commonwealth Center  
11003 Bluegrass Parkway  
Louisville, Ky 40299  
(502) 267-0700

DWN BY: CAE  
CHK'D BY: MSC  
DATUM:  
PROJECTION:  
SCALE: AS SHOWN

PROJECT: **ASSESSMENT OF DAM SAFETY OF COAL COMBUSTION SURFACE IMPOUNDMENTS**

TITLE: **KENTUCKY UTILITIES, SUBSIDIARY OF E.ON U.S. GREEN RIVER POWER STATION, CENTRAL CITY, KY ASH TREATMENT BASIN #1 SLOPE FAILURE CROSS SECTION**

DATE: **8/14/10**  
PROJECT NO: **3-2108-0177-0003**  
REV. NO.:  
FIGURE No. **10**

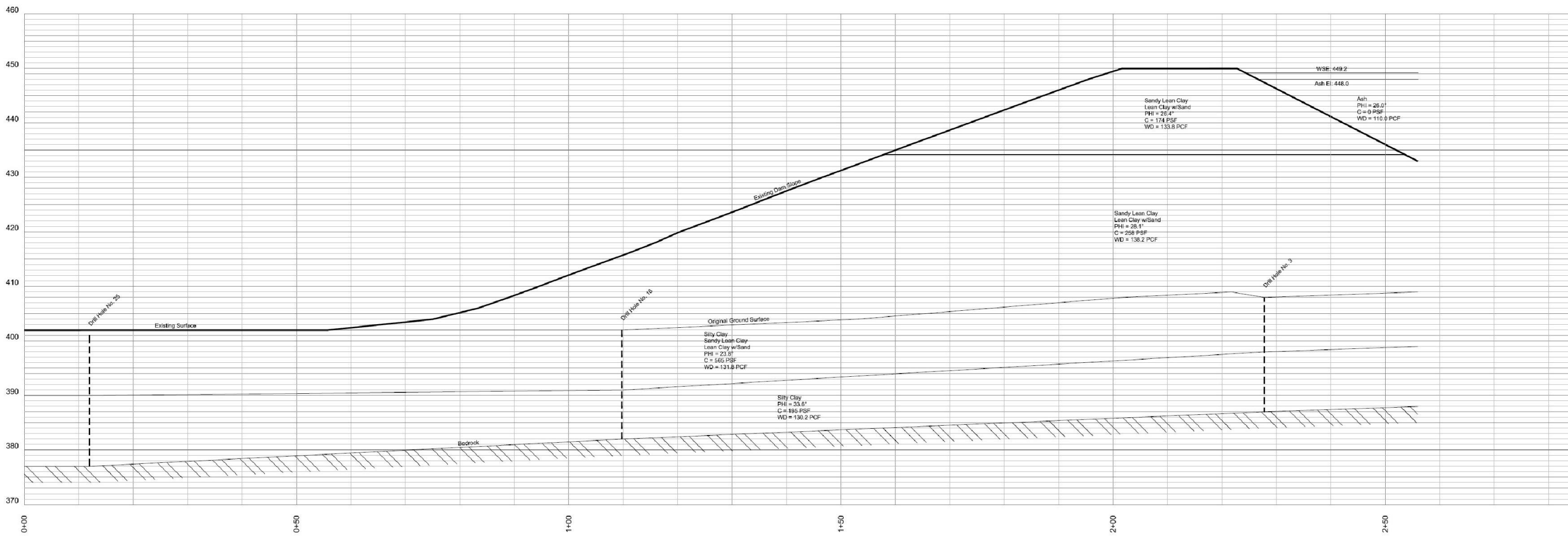

**SECTION B-B'  
CRITICAL SLOPE CROSS SECTION**

NOTE: THIS DRAWING SHOULD BE READ IN CONJUNCTION WITH THE AMEC EARTH & ENVIRONMENTAL REPORT



CLIENT: **UNITED STATES ENVIRONMENTAL PROTECTION AGENCY**

**AMEC Earth & Environmental**  
 690 Commonwealth Center  
 11003 Bluegrass Parkway  
 Louisville, Ky 40299  
 (502) 267-0700

DWN BY: CAE  
 CHK'D BY: MSC  
 DATUM:  
 PROJECTION:  
 SCALE: AS SHOWN

PROJECT **ASSESSMENT OF DAM SAFETY OF COAL COMBUSTION SURFACE IMPOUNDMENTS**

TITLE **KENTUCKY UTILITIES, SUBSIDIARY OF E.ON U.S. GREEN RIVER POWER STATION, CENTRAL CITY, KY ASH TREATMENT BASIN #1 CRITICAL SLOPE CROSS SECTION**

DATE: **8/14/10**  
 PROJECT NO: **3-2108-0177-0003**  
 REV. NO.:  
 FIGURE No. **11**



- APROXIMATE BORING LOCATION
- APROXIMATE PIEZOMETER LOCATION

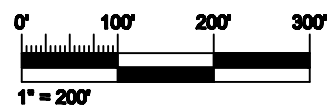

NOTE: THIS DRAWING SHOULD BE READ IN CONJUNCTION WITH THE AMEC EARTH & ENVIRONMENTAL REPORT

CLIENT LOGO



CLIENT:

**UNITED STATES ENVIRONMENTAL PROTECTION AGENCY**

**AMEC Earth & Environmental**

690 Commonwealth Center  
11003 Bluegrass Parkway  
Louisville, Ky 40299  
(502) 267-0700



DWN BY: CAE

CHK'D BY: MSC

DATUM:

PROJECTION:

SCALE: AS SHOWN

PROJECT **ASSESSMENT OF DAM SAFETY OF COAL COMBUSTION SURFACE IMPOUNDMENTS**

TITLE **KENTUCKY UTILITIES, SUBSIDIARY OF E.ON U.S. GREEN RIVER POWER STATION, CENTRAL CITY, KY BORING LOCATION PLAN AND SLOPE STABILITY SECTIONS**

DATE: 8/14/10

PROJECT NO: 3-2106-0177-0003

REV. NO.:

FIGURE No. 12

**APPENDIX A**  
**Waste Impoundment Inspection Forms**



Coal Combustion Waste (CCW) Impoundment Inspection

Impoundment NPDES Permit # KY 0002011 INSPECTOR James Black/Shea Carr
Date 08/16/2010

Impoundment Name Ash Treatment Basin #1 (or Main Pond)
Impoundment Company Kentucky Utilities (KU) Company (A subsidiary of EON-US)
EPA Region 4
State Agency (Field Office) Address 200 Fair Oaks Lane Frankfort, KY 40601

Name of Impoundment ATB #1 (Ash Treatment Basin #1 or Main Pond)
(Report each impoundment on a separate form under the same Impoundment NPDES Permit number)

New X Update

Is impoundment currently under construction? Yes No
Is water or ccw currently being pumped into the impoundment? X

IMPOUNDMENT FUNCTION: Storage and management coal combustion waste (CCW) byproducts

Nearest Downstream Town : Name Livermore, Kentucky
Distance from the impoundment 9 miles
Impoundment Location: Longitude -87 Degrees 7 Minutes 18.54 Seconds
Latitude 37 Degrees 22 Minutes 11.09 Seconds
State KY County Muhlenberg

Does a state agency regulate this impoundment? YES X NO

If So Which State Agency? State of Kentucky Division of Water

**HAZARD POTENTIAL** (In the event the impoundment should fail, the following would occur):

\_\_\_\_\_ **LESS THAN LOW HAZARD POTENTIAL:** Failure or misoperation of the dam results in no probable loss of human life or economic or environmental losses.

\_\_\_\_\_ **LOW HAZARD POTENTIAL:** Dams assigned the low hazard potential classification are those where failure or misoperation results in no probable loss of human life and low economic and/or environmental losses. Losses are principally limited to the owner's property.

  X   **SIGNIFICANT HAZARD POTENTIAL:** Dams assigned the significant hazard potential classification are those dams where failure or misoperation results in no probable loss of human life but can cause economic loss, environmental damage, disruption of lifeline facilities, or can impact other concerns. Significant hazard potential classification dams are often located in predominantly rural or agricultural areas but could be located in areas with population and significant infrastructure.

\_\_\_\_\_ **HIGH HAZARD POTENTIAL:** Dams assigned the high hazard potential classification are those where failure or misoperation will probably cause loss of human life.

**DESCRIBE REASONING FOR HAZARD RATING CHOSEN:**

Failure to Pond 2 to outlet ditch to Green River

---

---

---

---

---

---

---

---

---

---

---

---

---

---

---

---

---

---

---

---

---

---

---

---

---

**CONFIGURATION:**

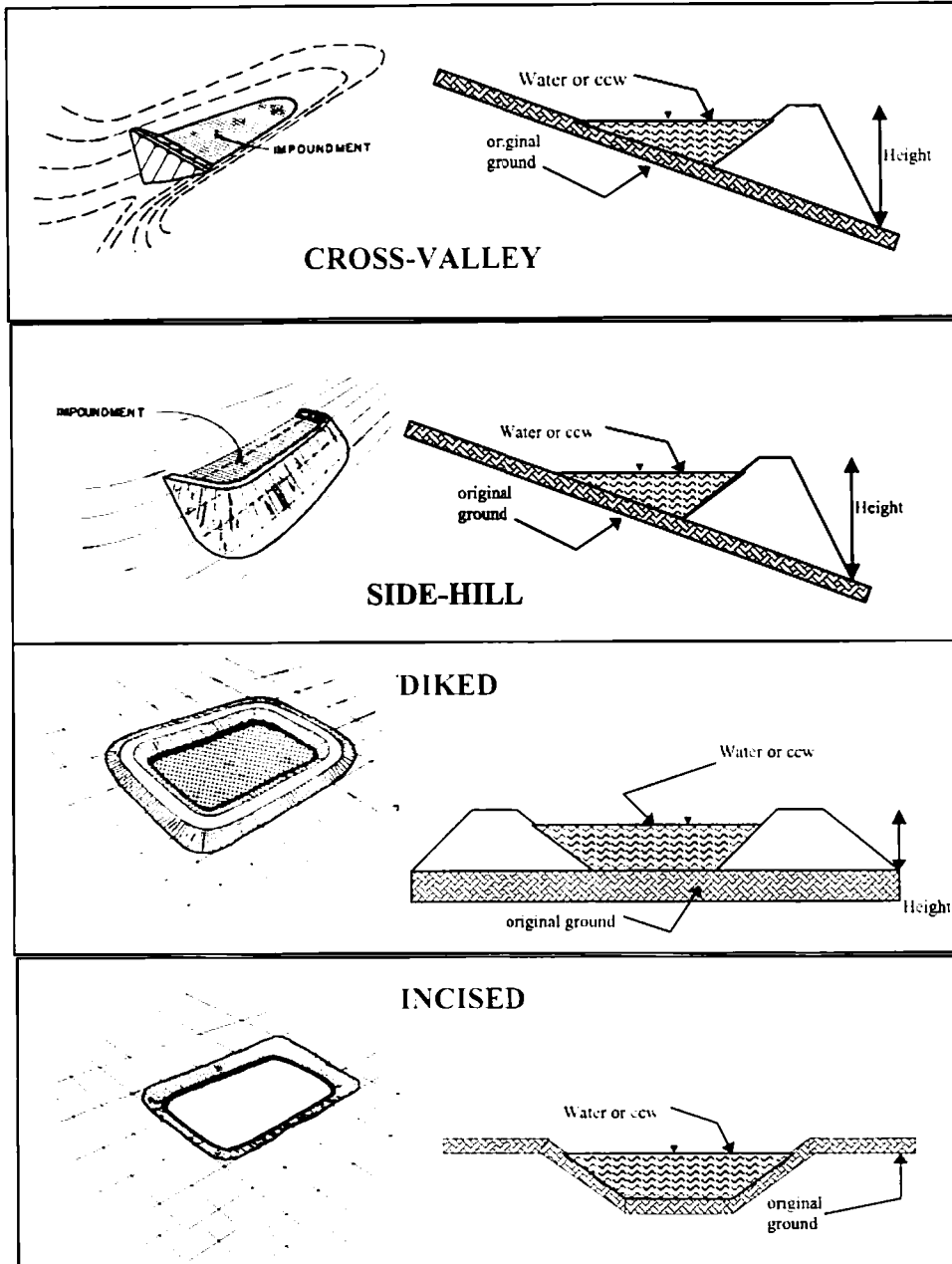

Cross-Valley  
 Side-Hill  
 Diked  
 Incised (form completion optional)  
 Combination Incised/Diked

Embankment Height 49.5 feet      Embankment Material Earthen Fill  
 Pool Area 32 acres      Liner N.A.  
 Current Freeboard 4.5 feet      Liner Permeability N.A.



**TYPE OF OUTLET** (Mark all that apply)

       **Open Channel Spillway**

- Trapezoidal
- Triangular
- Rectangular
- Irregular

- depth
- bottom (or average) width
- top width
- 

TRAPEZOIDAL

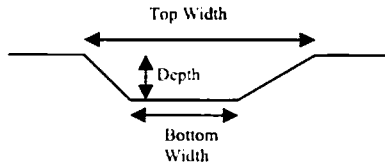

TRIANGULAR

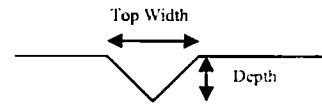

RECTANGULAR

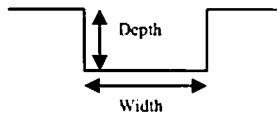

IRREGULAR

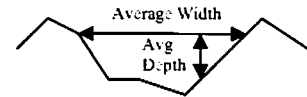

  X   **Outlet**

  36"   inside diameter

Material

- corrugated metal
- welded steel
- X   concrete
- plastic (hdpe, pvc, etc.)
- other (specify) \_\_\_\_\_

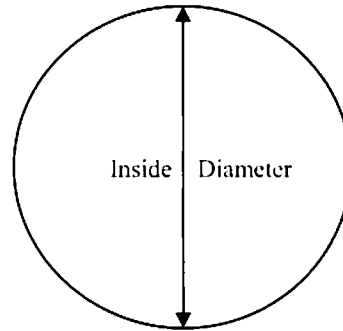

Is water flowing through the outlet? YES   X   NO \_\_\_\_\_

       **No Outlet**

       **Other Type of Outlet (specify)** \_\_\_\_\_

The Impoundment was Designed By   H.C. Nutting - James J. Flaig, PE









Site Name:	Green River Power Station	Date:	08/16/2010
Unit Name:	ATB #1 (or Main Pond)	Operator's Name:	Kentucky Utilities
Unit I.D.:	Hazard Potential Classification: High Significant Low		
Inspector's Name: James Black, Shea Carr			

Check the appropriate box below. Provide comments when appropriate. If not applicable or not available, record "N/A". Any unusual conditions or construction practices that should be noted in the comments section. For large diked embankments, separate checklists may be used for different embankment areas. If separate forms are used, identify approximate area that the form applies to in comments.

		Yes	No			Yes	No
1. Frequency of Company's Dam Inspections?	weekly			18. Sloughing or bulging on slopes?		✓	
2. Pool elevation (operator records)?	445.0			19. Major erosion or slope deterioration?			✓
3. Decant inlet elevation (operator records)?	444.5			20. Decant Pipes:			
4. Open channel spillway elevation (operator records)?	N/A			Is water entering inlet, but not exiting outlet?			✓
5. Lowest dam crest elevation (operator records)?	449.5			Is water exiting outlet, but not entering inlet?			✓
6. If instrumentation is present, are readings recorded (operator records)?	✓			Is water exiting outlet flowing clear?		✓	
7. Is the embankment currently under construction?			✓	21. Seepage (specify location, if seepage carries fines, and approximate seepage rate below):			
8. Foundation preparation (remove vegetation, stumps, topsoil in area where embankment fill will be placed)?	✓			From underdrain?			✓
9. Trees growing on embankment? (If so, indicate largest diameter below)			✓	At isolated points on embankment slopes?			✓
10. Cracks or scarps on crest?			✓	At natural hillside in the embankment area?			✓
11. Is there significant settlement along the crest?			✓	Over widespread areas?			✓
12. Are decant trashracks clear and in place?	✓			From downstream foundation area?			✓
13. Depressions or sinkholes in tailings surface or whirlpool in the pool area?			✓	"Boils" beneath stream or ponded water?			✓
14. Clogged spillways, groin or diversion ditches?			✓	Around the outside of the decant pipe?			✓
15. Are spillway or ditch linings deteriorated?			✓	22. Surface movements in valley bottom or on hillside?			✓
16. Are outlets of decant or underdrains blocked?			✓	23. Water against downstream toe?			✓
17. Cracks or scarps on slopes?			✓	24. Were Photos taken during the dam inspection?		✓	

Major adverse changes in these items could cause instability and should be reported for further evaluation. Adverse conditions noted in these items should normally be described (extent, location, volume, etc.) in the space below and on the back of this sheet.

Inspection Issue #	Comments
17.	No issues noted/observed; however, two slides on southern embankment have been previously repaired.
18.	Based on visual observations possible slope irregularities.



Coal Combustion Waste (CCW) Impoundment Inspection

Impoundment NPDES Permit # KY INSPECTOR James Black/Shea Carr
Date 08/16/2010

Impoundment Name Ash Treatment Basin #2
Impoundment Company Kentucky Utilities (KU) Company (A subsidiary of EON-US)
EPA Region 4
State Agency (Field Office) Address 200 Fair Oaks Lane
Frankfort, KY 40601

Name of Impoundment Ash Treatment Basin #2
(Report each impoundment on a separate form under the same Impoundment NPDES Permit number)

New X Update

Is impoundment currently under construction? Yes No
Is water or ccw currently being pumped into the impoundment? X

Storage and management coal combustion waste
IMPOUNDMENT FUNCTION: (CCW) byproducts

Nearest Downstream Town : Name Livernore, Kentucky
Distance from the impoundment 9 miles
Impoundment Location: Longitude -87 Degrees 7 Minutes 4.95 Seconds
Latitude 37 Degrees 22 Minutes 5.14 Seconds
State KY County Muhlenburg

Does a state agency regulate this impoundment? YES NO X

If So Which State Agency?

**HAZARD POTENTIAL** (In the event the impoundment should fail, the following would occur):

\_\_\_\_\_ **LESS THAN LOW HAZARD POTENTIAL:** Failure or misoperation of the dam results in no probable loss of human life or economic or environmental losses.

\_\_\_\_\_ **LOW HAZARD POTENTIAL:** Dams assigned the low hazard potential classification are those where failure or misoperation results in no probable loss of human life and low economic and/or environmental losses. Losses are principally limited to the owner’s property.

  X   **SIGNIFICANT HAZARD POTENTIAL:** Dams assigned the significant hazard potential classification are those dams where failure or misoperation results in no probable loss of human life but can cause economic loss, environmental damage, disruption of lifeline facilities, or can impact other concerns. Significant hazard potential classification dams are often located in predominantly rural or agricultural areas but could be located in areas with population and significant infrastructure.

\_\_\_\_\_ **HIGH HAZARD POTENTIAL:** Dams assigned the high hazard potential classification are those where failure or misoperation will probably cause loss of human life.

**DESCRIBE REASONING FOR HAZARD RATING CHOSEN:**

Outfall to Green River

---

---

---

---

---

---

---

---

---

---

---

---

---

---

---

---

**CONFIGURATION:**

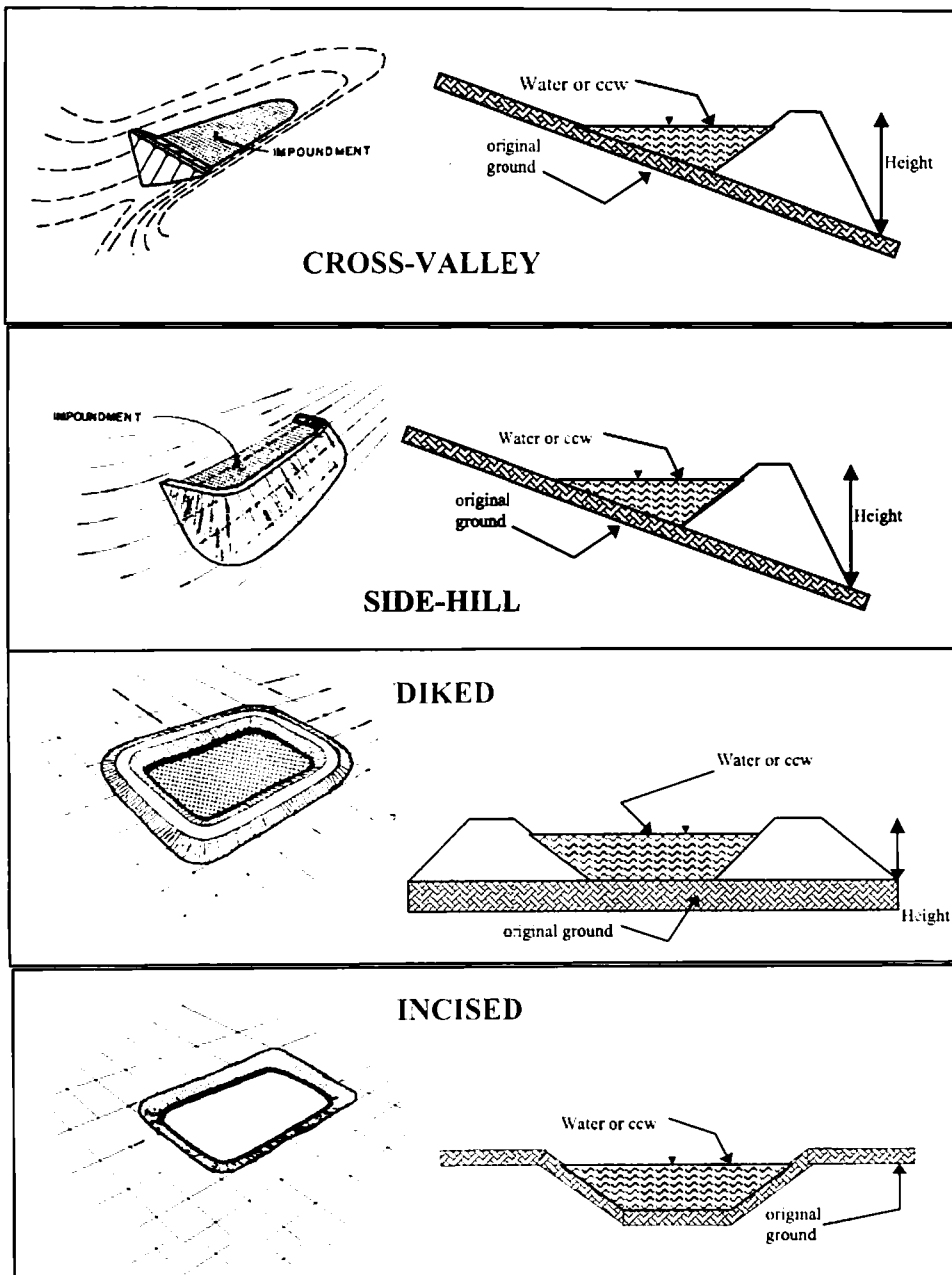

Cross-Valley  
 Side-Hill  
 Diked  
 Incised (form completion optional)  
 Combination Incised/Diked

Embankment Height 15 feet      Embankment Material Earthen Fill  
 Pool Area 23 acres      Liner N.A.  
 Current Freeboard 3 feet      Liner Permeability N.A.



**TYPE OF OUTLET** (Mark all that apply)

       **Open Channel Spillway**

- Trapezoidal
- Triangular
- Rectangular
- Irregular

TRAPEZOIDAL

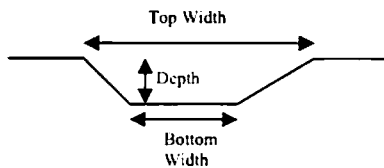

TRIANGULAR

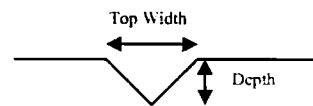

- depth
- bottom (or average) width
- top width

RECTANGULAR

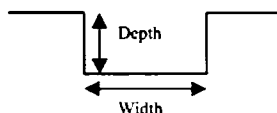

IRREGULAR

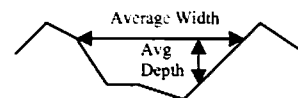

  X   **Outlet**

  30"   inside diameter

Material

- X   corrugated metal
- welded steel
- concrete
- plastic (hdpe, pvc, etc.)
- other (specify) \_\_\_\_\_

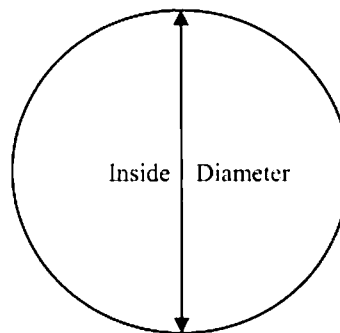

Is water flowing through the outlet? YES \_\_\_\_\_ NO \_\_\_\_\_

       **No Outlet**

       **Other Type of Outlet** (specify) \_\_\_\_\_

The Impoundment was Designed By   N.A.   Constructed in 1971

Has there ever been a failure at this site? YES \_\_\_\_\_ NO  \_\_\_\_\_

If So When? \_\_\_\_\_

If So Please Describe : \_\_\_\_\_

---

---

---

---

---

---

---

---

---

---

---

---

---

---

---

---

---

---

---

---

---

---

---

---

---

---

---

---

---

---







Site Name:	Green River Power Station	Date:	08/16/10
Unit Name:	Ash Pond #2	Operator's Name:	Kentucky Utilities
Unit I.D.:	Hazard Potential Classification: High <input checked="" type="checkbox"/> Significant <input checked="" type="checkbox"/> Low		
Inspector's Name: James Black, Shea Carr			

Check the appropriate box below. Provide comments when appropriate. If not applicable or not available, record "N/A". Any unusual conditions or construction practices that should be noted in the comments section. For large diked embankments, separate checklists may be used for different embankment areas. If separate forms are used, identify approximate area that the form applies to in comments.

	Yes	No		Yes	No
1. Frequency of Company's Dam Inspections?		weekly	18. Sloughing or bulging on slopes?		<input checked="" type="checkbox"/>
2. Pool elevation (operator records)?		397.0	19. Major erosion or slope deterioration?		<input checked="" type="checkbox"/>
3. Decant inlet elevation (operator records)?		397.5	20. Decant Pipes:		
4. Open channel spillway elevation (operator records)?		N/A	Is water entering inlet, but not exiting outlet?		<input checked="" type="checkbox"/>
5. Lowest dam crest elevation (operator records)?		400.0	Is water exiting outlet, but not entering inlet?		<input checked="" type="checkbox"/>
6. If instrumentation is present, are readings recorded (operator records)?	<input checked="" type="checkbox"/>		Is water exiting outlet flowing clear?	<input checked="" type="checkbox"/>	
7. Is the embankment currently under construction?		<input checked="" type="checkbox"/>	21. Seepage (specify location, if seepage carries fines, and approximate seepage rate below):		
8. Foundation preparation (remove vegetation, stumps, topsoil in area where embankment fill will be placed)?	N/A		From underdrain?		<input checked="" type="checkbox"/>
9. Trees growing on embankment? (If so, indicate largest diameter below)		<input checked="" type="checkbox"/>	At isolated points on embankment slopes?		<input checked="" type="checkbox"/>
10. Cracks or scarps on crest?		<input checked="" type="checkbox"/>	At natural hillside in the embankment area?		<input checked="" type="checkbox"/>
11. Is there significant settlement along the crest?		<input checked="" type="checkbox"/>	Over widespread areas?		<input checked="" type="checkbox"/>
12. Are decant trashracks clear and in place?	<input checked="" type="checkbox"/>		From downstream foundation area?		<input checked="" type="checkbox"/>
13. Depressions or sinkholes in tailings surface or whirlpool in the pool area?		<input checked="" type="checkbox"/>	"Boils" beneath stream or ponded water?		<input checked="" type="checkbox"/>
14. Clogged spillways, groin or diversion ditches?	N/A		Around the outside of the decant pipe?		<input checked="" type="checkbox"/>
15. Are spillway or ditch linings deteriorated?	N/A		22. Surface movements in valley bottom or on hillside?		<input checked="" type="checkbox"/>
16. Are outlets of decant or underdrains blocked?		<input checked="" type="checkbox"/>	23. Water against downstream toe?		<input checked="" type="checkbox"/>
17. Cracks or scarps on slopes?		<input checked="" type="checkbox"/>	24. Were Photos taken during the dam inspection?	<input checked="" type="checkbox"/>	

Major adverse changes in these items could cause instability and should be reported for further evaluation. Adverse conditions noted in these items should normally be described (extent, location, volume, etc.) in the space below and on the back of this sheet.

Inspection Issue #	Comments
5.	Regrading has increased crest from topo map of 399.1 to 400
6.	New PZ's (3) installed August 2010



Coal Combustion Waste (CCW) Impoundment Inspection

Impoundment NPDES Permit # KY 0002011 INSPECTOR James Black/Shea Carr
Date 08/16/2010

Impoundment Name Finishing Pond #3
Impoundment Company Kentucky Utilities (KU) Company (A subsidiary of EON-US)
EPA Region 4
State Agency (Field Office) Address 200 Fair Oaks Lane
Frankfort, KY 40601

Name of Impoundment Finishing Pond #3
(Report each impoundment on a separate form under the same Impoundment NPDES Permit number)

New X Update

Is impoundment currently under construction? Yes No
Is water or ccw currently being pumped into the impoundment? Yes No

Storage and management coal combustion waste
IMPOUNDMENT FUNCTION: (CCW) byproducts

Nearest Downstream Town : Name Livermore, Kentucky
Distance from the impoundment 9 miles
Impoundment Location: Longitude -87 Degrees 6 Minutes 56.76 Seconds
Latitude 37 Degrees 2 Minutes 58.63 Seconds
State KY County Muhlenberg

Does a state agency regulate this impoundment? YES NO X

If So Which State Agency?

**HAZARD POTENTIAL** (In the event the impoundment should fail, the following would occur): N/A Embankment slopes removed

       **LESS THAN LOW HAZARD POTENTIAL:** Failure or misoperation of the dam results in no probable loss of human life or economic or environmental losses.

       **LOW HAZARD POTENTIAL:** Dams assigned the low hazard potential classification are those where failure or misoperation results in no probable loss of human life and low economic and/or environmental losses. Losses are principally limited to the owner’s property.

       **SIGNIFICANT HAZARD POTENTIAL:** Dams assigned the significant hazard potential classification are those dams where failure or misoperation results in no probable loss of human life but can cause economic loss, environmental damage, disruption of lifeline facilities, or can impact other concerns. Significant hazard potential classification dams are often located in predominantly rural or agricultural areas but could be located in areas with population and significant infrastructure.

       **HIGH HAZARD POTENTIAL:** Dams assigned the high hazard potential classification are those where failure or misoperation will probably cause loss of human life.

**DESCRIBE REASONING FOR HAZARD RATING CHOSEN:**

Embankment slopes have been removed; therefore, a hazard potential classification was not assigned.

\_\_\_\_\_  
\_\_\_\_\_  
\_\_\_\_\_  
\_\_\_\_\_  
\_\_\_\_\_  
\_\_\_\_\_  
\_\_\_\_\_  
\_\_\_\_\_  
\_\_\_\_\_  
\_\_\_\_\_  
\_\_\_\_\_  
\_\_\_\_\_

**CONFIGURATION:**

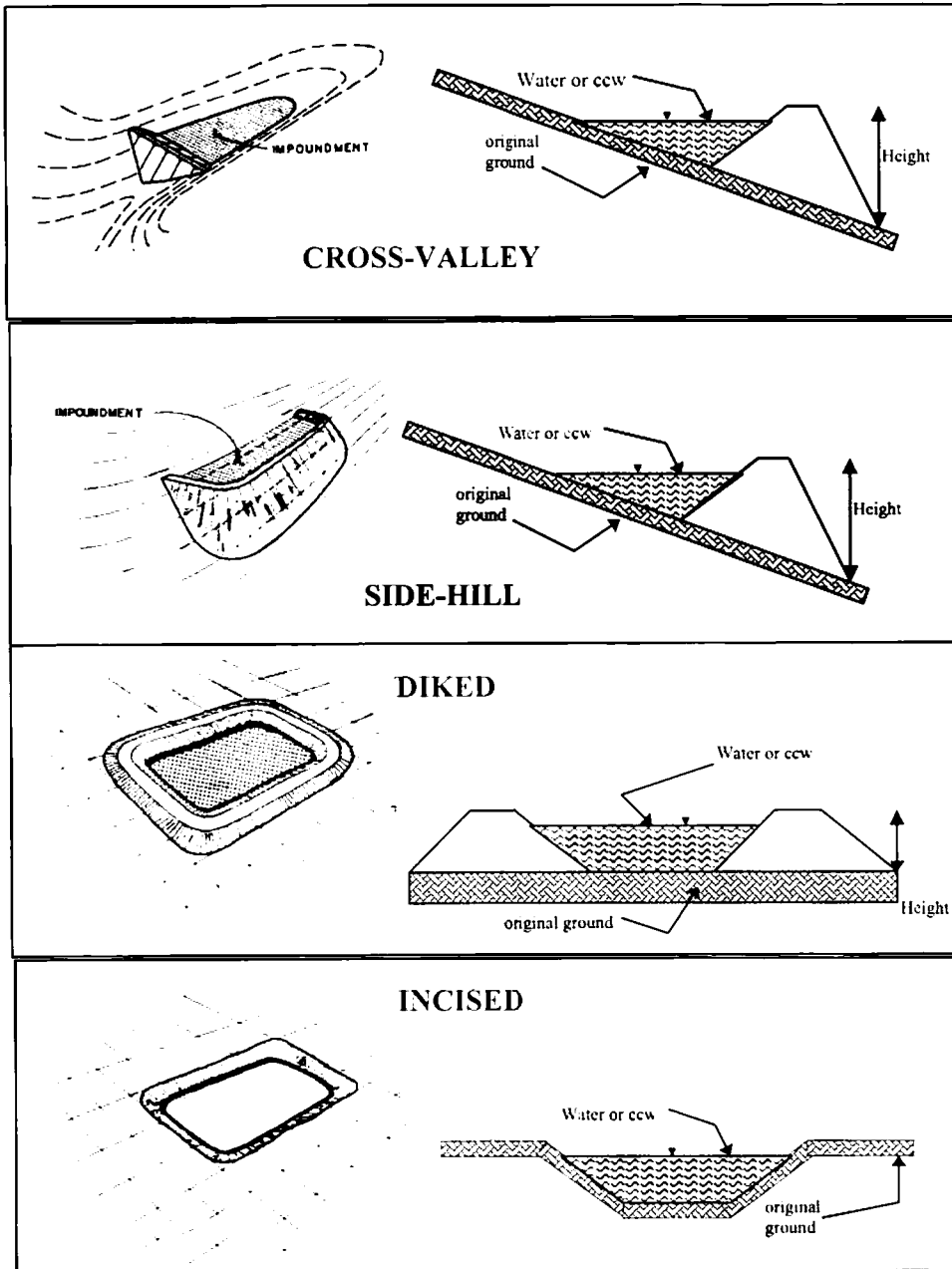

Cross-Valley  
 Side-Hill  
 Diked  
 Incised (form completion optional)  
 Combination Incised/Diked

Embankment Height     \* N.A.     feet    Embankment Material                                       
 Pool Area     2     acres    Liner                                       
 Current Freeboard                      feet    Liner Permeability                                     

\* Not a current storage basin. Outlet has been removed.



**TYPE OF OUTLET** (Mark all that apply)

       **Open Channel Spillway**

- Trapezoidal
- Triangular
- Rectangular
- Irregular

- depth
- bottom (or average) width
- top width

TRAPEZOIDAL

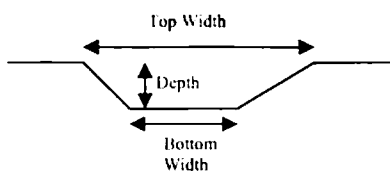

TRIANGULAR

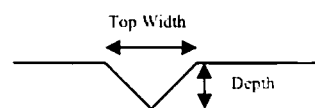

RECTANGULAR

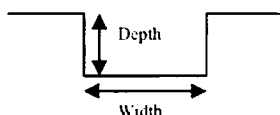

IRREGULAR

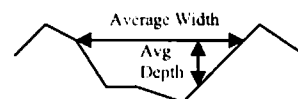

       **Outlet**

- inside diameter

**Material**

- corrugated metal
- welded steel
- concrete
- plastic (hdpe, pvc, etc.)
- other (specify) \_\_\_\_\_

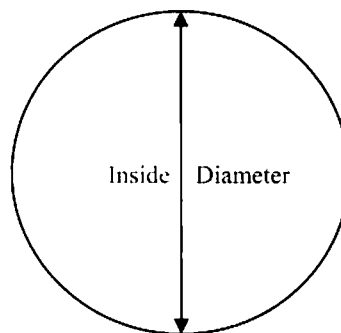

Is water flowing through the outlet? YES \_\_\_\_\_ NO \_\_\_\_\_

  X   **No Outlet**

       **Other Type of Outlet (specify)** \_\_\_\_\_

The Impoundment was Designed By   N.A.

Has there ever been a failure at this site? YES \_\_\_\_\_ NO

If So When? \_\_\_\_\_

If So Please Describe : \_\_\_\_\_  
\_\_\_\_\_  
\_\_\_\_\_  
\_\_\_\_\_  
\_\_\_\_\_  
\_\_\_\_\_  
\_\_\_\_\_  
\_\_\_\_\_  
\_\_\_\_\_  
\_\_\_\_\_  
\_\_\_\_\_  
\_\_\_\_\_  
\_\_\_\_\_  
\_\_\_\_\_  
\_\_\_\_\_  
\_\_\_\_\_  
\_\_\_\_\_  
\_\_\_\_\_  
\_\_\_\_\_  
\_\_\_\_\_  
\_\_\_\_\_  
\_\_\_\_\_  
\_\_\_\_\_  
\_\_\_\_\_  
\_\_\_\_\_  
\_\_\_\_\_  
\_\_\_\_\_  
\_\_\_\_\_  
\_\_\_\_\_  
\_\_\_\_\_  
\_\_\_\_\_  
\_\_\_\_\_  
\_\_\_\_\_  
\_\_\_\_\_  
\_\_\_\_\_  
\_\_\_\_\_  
\_\_\_\_\_  
\_\_\_\_\_  
\_\_\_\_\_  
\_\_\_\_\_  
\_\_\_\_\_  
\_\_\_\_\_  
\_\_\_\_\_  
\_\_\_\_\_  
\_\_\_\_\_  
\_\_\_\_\_







Site Name:	Finishing Pond #3	Date:	08/16/10
Unit Name:	Finishing Pond #3	Operator's Name:	Kentucky Utilities
Unit I.D.:	Hazard Potential Classification: High Significant Low		
Inspector's Name: James Black, Shea Carr			

Check the appropriate box below. Provide comments when appropriate. If not applicable or not available, record "N/A". Any unusual conditions or construction practices that should be noted in the comments section. For large diked embankments, separate checklists may be used for different embankment areas. If separate forms are used, identify approximate area that the form applies to in comments.

		Yes	No			Yes	No
1. Frequency of Company's Dam Inspections?				18. Sloughing or bulging on slopes?			
2. Pool elevation (operator records)?				19. Major erosion or slope deterioration?			
3. Decant inlet elevation (operator records)?				20. Decant Pipes:			
4. Open channel spillway elevation (operator records)?				Is water entering inlet, but not exiting outlet?			
5. Lowest dam crest elevation (operator records)?				Is water exiting outlet, but not entering inlet?			
6. If instrumentation is present, are readings recorded (operator records)?				Is water exiting outlet flowing clear?			
7. Is the embankment currently under construction?				21. Seepage (specify location, if seepage carries fines, and approximate seepage rate below):			
8. Foundation preparation (remove vegetation, stumps, topsoil in area where embankment fill will be placed)?				From underdrain?			
9. Trees growing on embankment? (If so, indicate largest diameter below)				At isolated points on embankment slopes?			
10. Cracks or scarps on crest?				At natural hillside in the embankment area?			
11. Is there significant settlement along the crest?				Over widespread areas?			
12. Are decant trashracks clear and in place?				From downstream foundation area?			
13. Depressions or sinkholes in tailings surface or whirlpool in the pool area?				"Boils" beneath stream or ponded water?			
14. Clogged spillways, groin or diversion ditches?				Around the outside of the decant pipe?			
15. Are spillway or ditch linings deteriorated?				22. Surface movements in valley bottom or on hillside?			
16. Are outlets of decant or underdrains blocked?				23. Water against downstream toe?			
17. Cracks or scarps on slopes?				24. Were Photos taken during the dam inspection?			

**Major adverse changes in these items could cause instability and should be reported for further evaluation. Adverse conditions noted in these items should normally be described (extent, location, volume, etc.) in the space below and on the back of this sheet.**

Inspection Issue #	Comments
	Embankment slopes removed.



Coal Combustion Waste (CCW) Impoundment Inspection

Impoundment NPDES Permit # KY 0002011 INSPECTOR James Black/Shea Carr
Date 08/16/2010

Impoundment Name Scrubber Pond
Impoundment Company Kentucky Utilities (KU) Company (A subsidiary of EON-US)
EPA Region 4
State Agency (Field Office) Address 200 Fair Oaks Lane
Frankfort, KY 40601

Name of Impoundment Scrubber Pond
(Report each impoundment on a separate form under the same Impoundment NPDES Permit number)

New X Update

Is impoundment currently under construction? Yes No
Is water or ccw currently being pumped into the impoundment? Yes No

Storage and management coal combustion waste
IMPOUNDMENT FUNCTION: (CCW) byproducts

Nearest Downstream Town : Name Livermore, Kentucky
Distance from the impoundment 9 miles
Impoundment Location: Longitude -87 Degrees 6 Minutes 54.83 Seconds
Latitude 37 Degrees 22 Minutes 5.26 Seconds
State KY County Muhlenberg

Does a state agency regulate this impoundment? YES X NO
If So Which State Agency? State of Kentucky Division of Water

**HAZARD POTENTIAL** (In the event the impoundment should fail, the following would occur):

       **LESS THAN LOW HAZARD POTENTIAL:** Failure or misoperation of the dam results in no probable loss of human life or economic or environmental losses.

       **LOW HAZARD POTENTIAL:** Dams assigned the low hazard potential classification are those where failure or misoperation results in no probable loss of human life and low economic and/or environmental losses. Losses are principally limited to the owner's property.

  X   **SIGNIFICANT HAZARD POTENTIAL:** Dams assigned the significant hazard potential classification are those dams where failure or misoperation results in no probable loss of human life but can cause economic loss, environmental damage, disruption of lifeline facilities, or can impact other concerns. Significant hazard potential classification dams are often located in predominantly rural or agricultural areas but could be located in areas with population and significant infrastructure.

       **HIGH HAZARD POTENTIAL:** Dams assigned the high hazard potential classification are those where failure or misoperation will probably cause loss of human life.

**DESCRIBE REASONING FOR HAZARD RATING CHOSEN:**

Failure would reach Green River

---

---

---

---

---

---

---

---

---

---

---

---

---

---

---

---

---

**CONFIGURATION:**

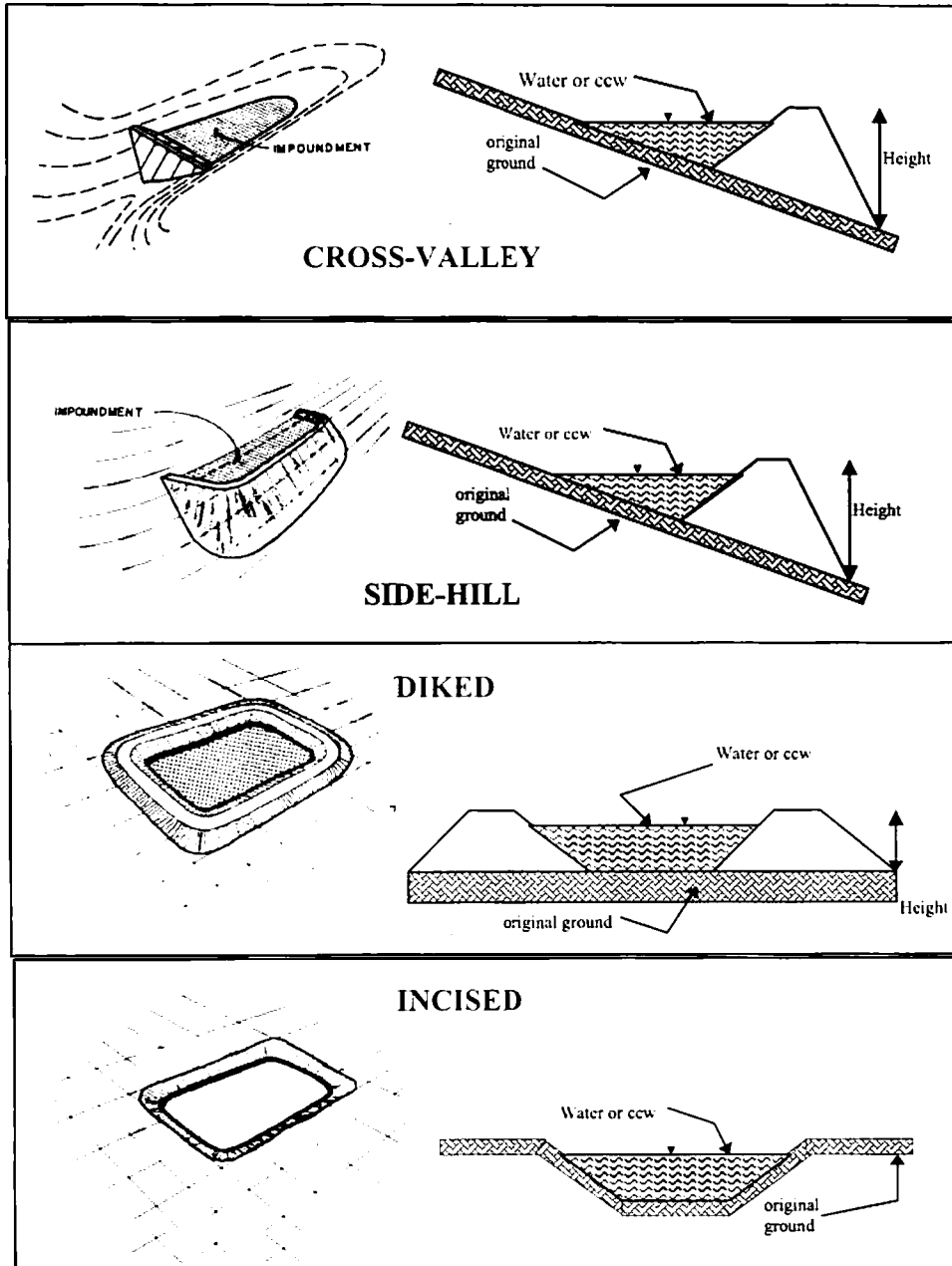

Cross-Valley  
 Side-Hill  
 Diked  
 Incised (form completion optional)  
 Combination Incised/Diked

Embankment Height 17 feet      Embankment Material Earthen Fill  
 Pool Area 10 acres      Liner N.A.  
 Current Freeboard 5 feet      Liner Permeability N.A.



**TYPE OF OUTLET** (Mark all that apply)

       **Open Channel Spillway**

- Trapezoidal
- Triangular
- Rectangular
- Irregular

TRAPEZOIDAL

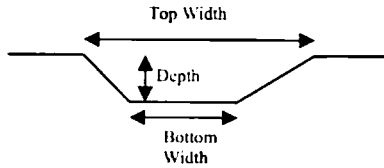

TRIANGULAR

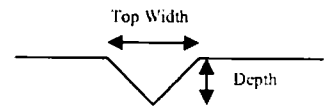

- depth
- bottom (or average) width
- top width

RECTANGULAR

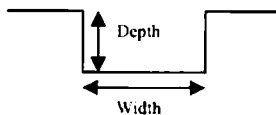

IRREGULAR

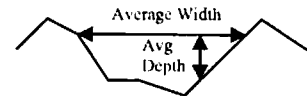

       **Outlet**

- inside diameter

Material

- corrugated metal
- welded steel
- concrete
- plastic (hdpe, pvc, etc.)
- other (specify) \_\_\_\_\_

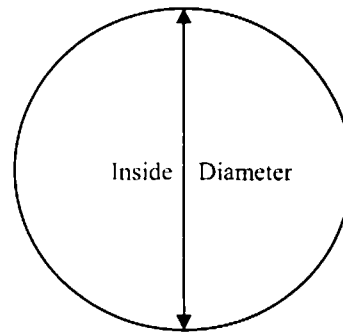

Is water flowing through the outlet? YES \_\_\_\_\_ NO \_\_\_\_\_

  X   **No Outlet** Scrubber pond is pumped to pond #2 twice a year

       **Other Type of Outlet** (specify) \_\_\_\_\_

The Impoundment was Designed By 1974 Sargent and Lundy



Has there ever been significant seepages at this site? YES \_\_\_\_\_ NO  X

If So When? \_\_\_\_\_

IF So Please Describe: \_\_\_\_\_

\_\_\_\_\_

\_\_\_\_\_

\_\_\_\_\_

\_\_\_\_\_

\_\_\_\_\_

\_\_\_\_\_

\_\_\_\_\_

\_\_\_\_\_

\_\_\_\_\_

\_\_\_\_\_

\_\_\_\_\_

\_\_\_\_\_

\_\_\_\_\_

\_\_\_\_\_

\_\_\_\_\_

\_\_\_\_\_

\_\_\_\_\_

\_\_\_\_\_

\_\_\_\_\_

\_\_\_\_\_

\_\_\_\_\_

\_\_\_\_\_

\_\_\_\_\_

\_\_\_\_\_

\_\_\_\_\_

\_\_\_\_\_

\_\_\_\_\_

\_\_\_\_\_

\_\_\_\_\_





Site Name:	Green River Power Station	Date:	08/16/10
Unit Name:	Scrubber Pond	Operator's Name:	Kentucky Utilities
Unit I.D.:	Hazard Potential Classification: High Significant <input checked="" type="checkbox"/> Low		
Inspector's Name: James Black, Shea Carr			

Check the appropriate box below. Provide comments when appropriate. If not applicable or not available, record "N/A". Any unusual conditions or construction practices that should be noted in the comments section. For large diked embankments, separate checklists may be used for different embankment areas. If separate forms are used, identify approximate area that the form applies to in comments.

	Yes No			Yes No	
	<input type="checkbox"/>	<input type="checkbox"/>		<input type="checkbox"/>	<input type="checkbox"/>
1. Frequency of Company's Dam Inspections?		weekly	18. Sloughing or bulging on slopes?		<input checked="" type="checkbox"/>
2. Pool elevation (operator records)?		398.5	19. Major erosion or slope deterioration?	<input checked="" type="checkbox"/>	
3. Decant inlet elevation (operator records)?		N/A	20. Decant Pipes:		
4. Open channel spillway elevation (operator records)?		N/A	Is water entering inlet, but not exiting outlet?		<input checked="" type="checkbox"/>
5. Lowest dam crest elevation (operator records)?		403.6	Is water exiting outlet, but not entering inlet?		<input checked="" type="checkbox"/>
6. If instrumentation is present, are readings recorded (operator records)?	<input checked="" type="checkbox"/>		Is water exiting outlet flowing clear?		N/A
7. Is the embankment currently under construction?		<input checked="" type="checkbox"/>	21. Seepage (specify location, if seepage carries fines, and approximate seepage rate below):		
8. Foundation preparation (remove vegetation, stumps, topsoil in area where embankment fill will be placed)?		N/A	From underdrain?		<input checked="" type="checkbox"/>
9. Trees growing on embankment? (If so, indicate largest diameter below)		<input checked="" type="checkbox"/>	At isolated points on embankment slopes?	<input checked="" type="checkbox"/>	
10. Cracks or scarps on crest?		<input checked="" type="checkbox"/>	At natural hillside in the embankment area?		<input checked="" type="checkbox"/>
11. Is there significant settlement along the crest?		<input checked="" type="checkbox"/>	Over widespread areas?		<input checked="" type="checkbox"/>
12. Are decant trashracks clear and in place?		<input checked="" type="checkbox"/>	From downstream foundation area?		<input checked="" type="checkbox"/>
13. Depressions or sinkholes in tailings surface or whirlpool in the pool area?		<input checked="" type="checkbox"/>	"Boils" beneath stream or ponded water?		<input checked="" type="checkbox"/>
14. Clogged spillways, groin or diversion ditches?		<input checked="" type="checkbox"/>	Around the outside of the decant pipe?		<input checked="" type="checkbox"/>
15. Are spillway or ditch linings deteriorated?		N/A	22. Surface movements in valley bottom or on hillside?		<input checked="" type="checkbox"/>
16. Are outlets of decant or underdrains blocked?		N/A	23. Water against downstream toe?		<input checked="" type="checkbox"/>
17. Cracks or scarps on slopes?		<input checked="" type="checkbox"/>	24. Were Photos taken during the dam inspection?	<input checked="" type="checkbox"/>	

Major adverse changes in these items could cause instability and should be reported for further evaluation. Adverse conditions noted in these items should normally be described (extent, location, volume, etc.) in the space below and on the back of this sheet.

Inspection Issue #	Comments
19.	Inside face of south and east face of dike
21.	South and west dike - some isolated wet areas at the toe of embankment (possibly from recent rain due to poor grading).
6.	Piezometers installed in August 2010.



Coal Combustion Waste (CCW) Impoundment Inspection

Impoundment NPDES Permit # KY 0002011 INSPECTOR James Black/Shea Carr
Date 08/16/2010

Impoundment Name Former Ash Pond (Current coal run-off pond)
Impoundment Company Kentucky Utilities (KU) Company (A subsidiary of EON-US)
EPA Region 4
State Agency (Field Office) Address 200 Fair Oaks Lane
Frankfort, KY 40601

Name of Impoundment Former Ash Pond (Current coal run-off pond)
(Report each impoundment on a separate form under the same Impoundment NPDES Permit number)

New X Update

Is impoundment currently under construction? Yes No
Is water or ccw currently being pumped into the impoundment? X

Storage and management coal combustion waste
IMPOUNDMENT FUNCTION: (CCW) byproducts

Nearest Downstream Town : Name Livermore, Kentucky
Distance from the impoundment 9 miles
Impoundment Location: Longitude -87 Degrees 7 Minutes 10.90 Seconds
Latitude 37 Degrees 21 Minutes 56.05 Seconds
State KY County Muhlenberg

Does a state agency regulate this impoundment? YES NO X

If So Which State Agency?

**HAZARD POTENTIAL** (In the event the impoundment should fail, the following would occur):

         **LESS THAN LOW HAZARD POTENTIAL:** Failure or misoperation of the dam results in no probable loss of human life or economic or environmental losses.

         **LOW HAZARD POTENTIAL:** Dams assigned the low hazard potential classification are those where failure or misoperation results in no probable loss of human life and low economic and/or environmental losses. Losses are principally limited to the owner's property.

  X   **SIGNIFICANT HAZARD POTENTIAL:** Dams assigned the significant hazard potential classification are those dams where failure or misoperation results in no probable loss of human life but can cause economic loss, environmental damage, disruption of lifeline facilities, or can impact other concerns. Significant hazard potential classification dams are often located in predominantly rural or agricultural areas but could be located in areas with population and significant infrastructure.

         **HIGH HAZARD POTENTIAL:** Dams assigned the high hazard potential classification are those where failure or misoperation will probably cause loss of human life.

**DESCRIBE REASONING FOR HAZARD RATING CHOSEN:**

Failure to Pond 2 to outlet ditch to Green River  
\_\_\_\_\_  
\_\_\_\_\_  
\_\_\_\_\_  
\_\_\_\_\_  
\_\_\_\_\_  
\_\_\_\_\_  
\_\_\_\_\_  
\_\_\_\_\_  
\_\_\_\_\_  
\_\_\_\_\_  
\_\_\_\_\_  
\_\_\_\_\_  
\_\_\_\_\_  
\_\_\_\_\_  
\_\_\_\_\_  
\_\_\_\_\_  
\_\_\_\_\_

**CONFIGURATION:**

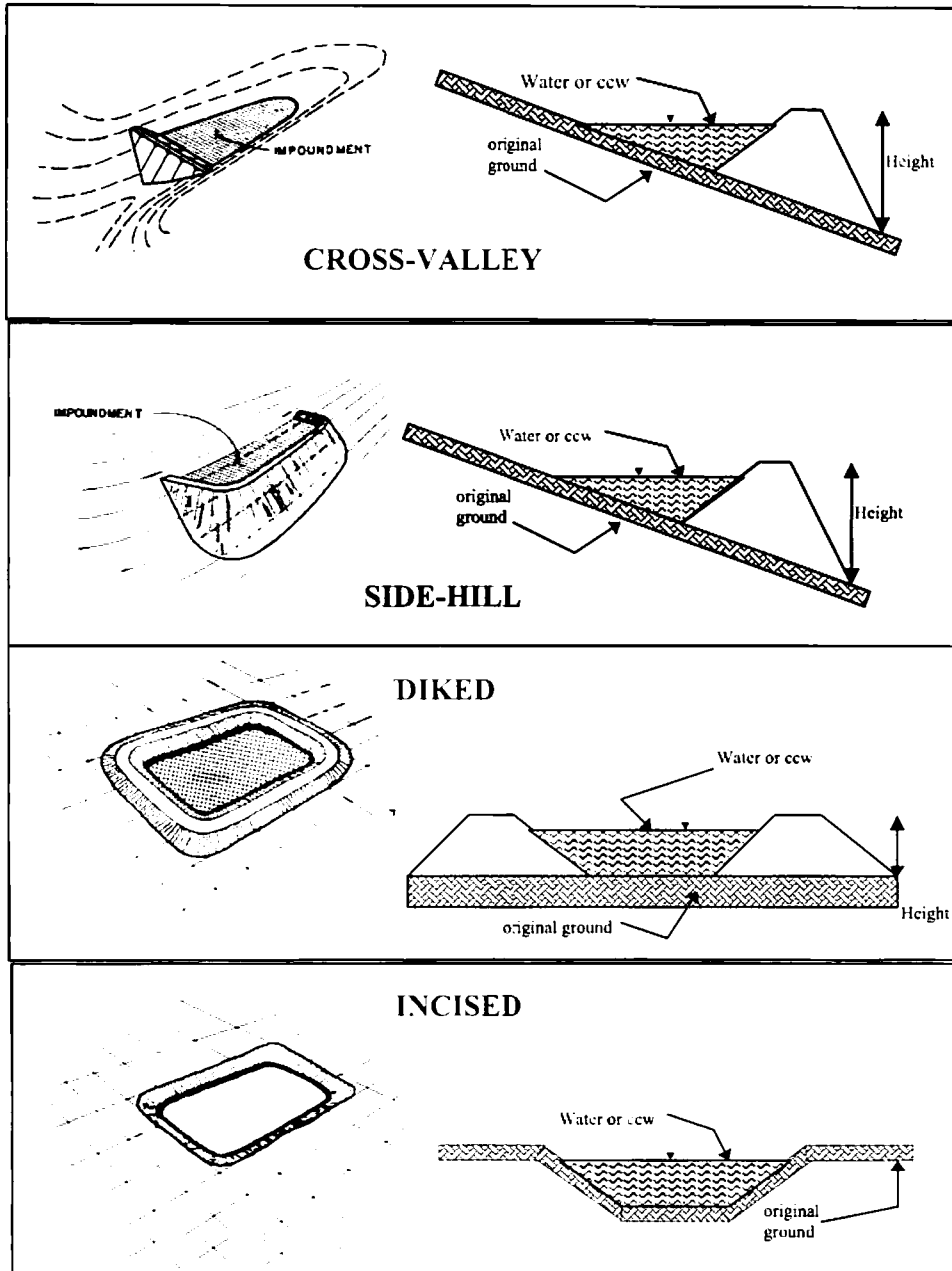

Cross-Valley

Side-Hill

Diked

Incised (form completion optional)

Combination Incised/Diked

Embankment Height 20 feet

Pool Area 6 acres

Current Freeboard 3.4 feet

Embankment Material Earthen embankment

Liner N.A. \*

Liner Permeability N.A. \*

\* constructed in late 1940's



**TYPE OF OUTLET** (Mark all that apply)

       **Open Channel Spillway**

- Trapezoidal
- Triangular
- Rectangular
- Irregular

- depth
- bottom (or average) width
- top width

TRAPEZOIDAL

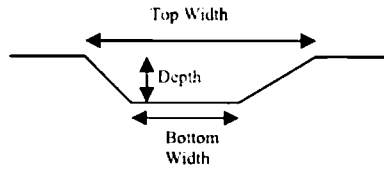

TRIANGULAR

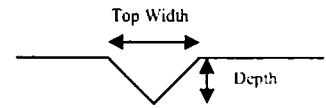

RECTANGULAR

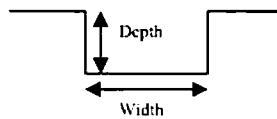

IRREGULAR

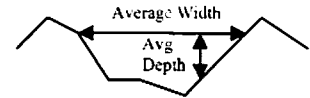

  X   **Outlet**

  18"   inside diameter

Material

- X   corrugated metal
- welded steel
- concrete
- plastic (hdpe, pvc, etc.)
- other (specify) \_\_\_\_\_

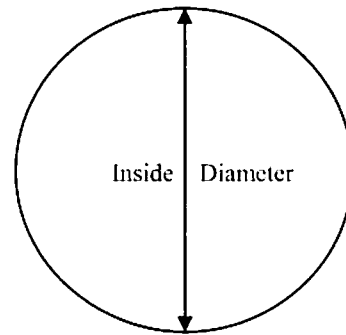

Is water flowing through the outlet? YES   X   NO \_\_\_\_\_

       **No Outlet**

       **Other Type of Outlet (specify)** \_\_\_\_\_

The Impoundment was Designed By   N.A.   Constructed in mid-1940's

Has there ever been a failure at this site? YES \_\_\_\_\_ NO X \_\_\_\_\_

If So When? \_\_\_\_\_

If So Please Describe : \_\_\_\_\_

Lined area for describing the failure details.



Has there ever been any measures undertaken to monitor/lower  
Phreatic water table levels based on past seepages or breaches  
at this site? YES \_\_\_\_\_ NO X

If so, which method (e.g., piezometers, gw pumping,...)? 1 piezometer

If so Please Describe : One piezometer installed in August 2010.  
No measurements taken at this time.

---

---

---

---

---

---

---

---

---

---

---

---

---

---

---

---

---

---

---

---

---

---

---

---

---

---

---

---

---

---



Site Name:	Green River Power Station	Date:	08/16/10
Unit Name:	Coal run-off pond	Operator's Name:	Kentucky Utilities
Unit I.D.:	Hazard Potential Classification: High Significant <input checked="" type="checkbox"/> Low		
Inspector's Name: James Black, Shea Carr			

Check the appropriate box below. Provide comments when appropriate. If not applicable or not available, record "N/A". Any unusual conditions or construction practices that should be noted in the comments section. For large diked embankments, separate checklists may be used for different embankment areas. If separate forms are used, identify approximate area that the form applies to in comments.

	Yes	No		Yes	No
1. Frequency of Company's Dam Inspections?		weekly	18. Sloughing or bulging on slopes?		<input checked="" type="checkbox"/>
2. Pool elevation (operator records)?		401.6	19. Major erosion or slope deterioration?		<input checked="" type="checkbox"/>
3. Decant inlet elevation (operator records)?		400.8	20. Decant Pipes:		
4. Open channel spillway elevation (operator records)?		N/A	Is water entering inlet, but not exiting outlet?		<input checked="" type="checkbox"/>
5. Lowest dam crest elevation (operator records)?		405.1	Is water exiting outlet, but not entering inlet?		<input checked="" type="checkbox"/>
6. If instrumentation is present, are readings recorded (operator records)?	<input checked="" type="checkbox"/>		Is water exiting outlet flowing clear?	<input checked="" type="checkbox"/>	
7. Is the embankment currently under construction?		<input checked="" type="checkbox"/>	21. Seepage (specify location, if seepage carries fines, and approximate seepage rate below):		
8. Foundation preparation (remove vegetation, stumps, topsoil in area where embankment fill will be placed)?	N/A		From underdrain?		<input checked="" type="checkbox"/>
9. Trees growing on embankment? (If so, indicate largest diameter below)		<input checked="" type="checkbox"/>	At isolated points on embankment slopes?		<input checked="" type="checkbox"/>
10. Cracks or scarps on crest?		<input checked="" type="checkbox"/>	At natural hillside in the embankment area?		<input checked="" type="checkbox"/>
11. Is there significant settlement along the crest?		<input checked="" type="checkbox"/>	Over widespread areas?		<input checked="" type="checkbox"/>
12. Are decant trashracks clear and in place?	<input checked="" type="checkbox"/>		From downstream foundation area?		<input checked="" type="checkbox"/>
13. Depressions or sinkholes in tailings surface or whirlpool in the pool area?		<input checked="" type="checkbox"/>	"Boils" beneath stream or ponded water?		<input checked="" type="checkbox"/>
14. Clogged spillways, groin or diversion ditches?	N/A		Around the outside of the decant pipe?		<input checked="" type="checkbox"/>
15. Are spillway or ditch linings deteriorated?	N/A		22. Surface movements in valley bottom or on hillside?		<input checked="" type="checkbox"/>
16. Are outlets of decant or underdrains blocked?		<input checked="" type="checkbox"/>	23. Water against downstream toe?		<input checked="" type="checkbox"/>
17. Cracks or scarps on slopes?		<input checked="" type="checkbox"/>	24. Were Photos taken during the dam inspection?	<input checked="" type="checkbox"/>	

Major adverse changes in these items could cause instability and should be reported for further evaluation. Adverse conditions noted in these items should normally be described (extent, location, volume, etc.) in the space below and on the back of this sheet.

Inspection Issue #	Comments
6.	One new PZ installed August 2010

**APPENDIX B**  
**Site Photo Log Map and Site Photos**

# Legend

Photo Location



UNITED STATES  
ENVIRONMENTAL PROTECTION AGENCY

DWN BY: DJC

CKD BY: MS

Datum: NAD 83

Projection: Albers

Scale: As Shown

## ASSESSMENT OF DAM SAFETY OF COAL COMBUSTION SURFACE IMPOUNDMENTS

GREEN RIVER POWER STATION  
CENTRAL CITY, KY  
ASH PONDS  
PHOTO LOCATION MAP

REV. No.: A

Date: 9-14-10

Project No: 3-2106-0177-0002

Figure No: B-1

AMEC Earth & Environmental  
690 Commonwealth Business Center  
11003 Bluegrass Parkway  
Louisville, KY 40299



Note: Direction(s) in Photos from Plant North (Green River is South)



**M-1**

**LOOKING NW AT WEST DIKE - CREST, UPSTREAM SLOPE, POND INTERIOR**



**M-2**

**LOOKING NW AT WEST DIKE - CREST AND DOWNSTREAM SLOPE, SPARSE GRASS COVER**

**AMEC Earth & Environmental**

690 Commonwealth Center  
11003 Bluegrass Parkway  
Louisville, Ky 40239  
(502) 267-0700



**CLIENT LOGO**



**CLIENT**  
**UNITED STATES ENVIRONMENTAL PROTECTION AGENCY**

**PROJECT**  
**ASSESSMENT OF DAM SAFETY OF COAL COMBUSTION SURFACE IMPOUNDMENTS**

**DWN BY:** CAE

**DATUM:**

**DATE:** 8/19/10

**TITLE**  
**KENTUCKY UTILITIES, SUBSIDIARY OF E.ON U.S.**  
**GREEN RIVER POWER STATION, CENTRAL CITY., KY**  
**ASH TREATMENT BASIN #1 SITE PHOTOS**

**CHK'D BY:** MGS

**REV. NO.:**

**PROJECT NO:** 3-2106-0177-0002

**PROJECTION:**

**SCALE:**

**PAGE NO.:**

**B-2**



Note: Direction(s) in Photos from Plant North (Green River is South)





**M-3**

**LOOKING NW FROM WEST END OF SOUTH DIKE -  
ASH STACKED TO NEAR CREST OF SOUTH DIKE**



**M-4**

**LOOKING S AT WEST DIKE - CREST AND UPSTREAM SLOPE**

<b>AMEC Earth &amp; Environmental</b> 690 Commonwealth Center 11003 Bluegrass Parkway Louisville, Ky 40239 (502) 267-0700				<b>CLIENT LOGO</b> 		<b>CLIENT</b> <b>UNITED STATES ENVIRONMENTAL PROTECTION AGENCY</b>			
<b>PROJECT</b> ASSESSMENT OF DAM SAFETY OF COAL COMBUSTION SURFACE IMPOUNDMENTS				<b>DWN BY:</b> CAE		<b>DATUM:</b>		<b>DATE:</b> 8/19/10	
<b>TITLE</b> KENTUCKY UTILITIES, SUBSIDIARY OF E.ON U.S. GREEN RIVER POWER STATION, CENTRAL CITY., KY ASH TREATMENT BASIN #1 SITE PHOTOS				<b>CHK'D BY:</b> MGS		<b>REV. NO.:</b>		<b>PROJECT NO:</b> 3-2106-0177-0002	
				<b>PROJECTION:</b>		<b>SCALE:</b>		<b>PAGE NO.:</b> B-3	

Note: Direction(s) in Photos from Plant North (Green River is South)



**M-5**

**LOOKING E FROM WEST END OF SOUTH DIKE - DOWNSTREAM SLOPE**



**M-6**

**LOOKING E FROM WEST PORTION OF SOUTH DIKE -  
CREST, NEW PZ-P3A ON SOUTH EDGE OF ROAD**

**AMEC Earth & Environmental**

890 Commonwealth Center  
11003 Bluegrass Parkway  
Louisville, Ky 40289  
(502) 267-0700



**CLIENT**  
**UNITED STATES ENVIRONMENTAL PROTECTION AGENCY**

**PROJECT**  
**ASSESSMENT OF DAM SAFETY OF COAL COMBUSTION SURFACE IMPOUNDMENTS**

**DWN BY:** CAE

**DATUM:**

**DATE:** 8/19/10

**TITLE**  
**KENTUCKY UTILITIES, SUBSIDIARY OF E.ON U.S.**  
**GREEN RIVER POWER STATION, CENTRAL CITY., KY**  
**ASH TREATMENT BASIN #1 SITE PHOTOS**

**CHK'D BY:** MGS

**REV. NO.:**

**PROJECT NO:** 3-2106-0177-0002

**PROJECTION:**

**SCALE:**

**PAGE NO.:**

**B-4**

Note: Direction(s) in Photos from Plant North (Green River is South)



**M-7**

**LOOKING S FROM WEST PORTION OF SOUTH DIKE -  
CREST, NEW PZ BEYOND TOE, EDGE OF COAL PILE**



**M-8**

**LOOKING W FROM WEST PORTION OF SOUTH DIKE - SLUICE PIPES CROSSING  
EMBANMENT, ASH STACKED TO NEAR CREST OF SOUTH DIKE**

**AMEC Earth & Environmental**

690 Commonwealth Center  
11003 Bluegrass Parkway  
Louisville, Ky 40239  
(502) 267-0700



**CLIENT LOGO**



**CLIENT**

**UNITED STATES  
ENVIRONMENTAL  
PROTECTION AGENCY**

**PROJECT**  
**ASSESSMENT OF DAM SAFETY OF COAL COMBUSTION SURFACE IMPOUNDMENTS**

**DWN BY:**  
**CAE**

**DATUM:**

**DATE:**  
**8/19/10**

**TITLE**  
**KENTUCKY UTILITIES, SUBSIDIARY OF E.ON U.S.**  
**GREEN RIVER POWER STATION, CENTRAL CITY., KY**  
**ASH TREATMENT BASIN #1 SITE PHOTOS**

**CHK'D BY:**  
**MGS**

**REV. NO.:**

**PROJECT NO:**  
**3-2106-0177-0002**

**PROJECTION:**

**SCALE:**

**PAGE NO.:**  
**B-5**

Note: Direction(s) in Photos from Plant North (Green River is South)



08/16/2010

**M-9**

**LOOKING S FROM SOUTH DIKE - AREAS WITH SPARSE GRASS ON DOWNSTREAM CREST, WEST BUTTRESS, AND COAL RUNOFF POND IN BACKGROUND**



08/16/2010

**M-10**

**LOOKING E FROM SOUTH DIKE - CRUSHED STONE CREST, UPPER POND INTERIOR AND OUTLET STRUCTURE**

**AMEC Earth & Environmental**

690 Commonwealth Center  
11003 Bluegrass Parkway  
Louisville, Ky 40239  
(502) 267-0700



**CLIENT LOGO**



**CLIENT**

**UNITED STATES ENVIRONMENTAL PROTECTION AGENCY**

**PROJECT**  
ASSESSMENT OF DAM SAFETY OF COAL COMBUSTION SURFACE IMPOUNDMENTS

**DWN BY:** CAE

**DATUM:**

**DATE:** 8/19/10

**TITLE**  
KENTUCKY UTILITIES, SUBSIDIARY OF E.ON U.S.  
GREEN RIVER POWER STATION, CENTRAL CITY., KY  
ASH TREATMENT BASIN #1 SITE PHOTOS

**CHK'D BY:** MGS

**REV. NO.:**

**PROJECT NO:** 3-2106-0177-0002

**PROJECTION:**

**SCALE:**

**PAGE NO.:**

**B-6**

Note: Direction(s) in Photos from Plant North (Green River is South)



**M-11**

**LOOKING E FROM SOUTH DIKE - DOWNSTREAM SLOPE**



**M-12**

**LOOKING E FROM SOUTH DIKE - AREAS OF SPARSE GRASS COVER, PIPE OUTLET OF OUTLET STRUCTURE ON RIGHT, AND EAST BUTTRESS**

**AMEC Earth & Environmental**

690 Commonwealth Center  
11003 Bluegrass Parkway  
Louisville, Ky 40239  
(502) 267-0700



**CLIENT LOGO**



**CLIENT**

**UNITED STATES ENVIRONMENTAL PROTECTION AGENCY**

**PROJECT**  
ASSESSMENT OF DAM SAFETY OF COAL COMBUSTION SURFACE IMPOUNDMENTS

**DWN BY:** CAE

**DATUM:**

**DATE:** 8/19/10

**TITLE**  
KENTUCKY UTILITIES, SUBSIDIARY OF E.ON U.S.  
GREEN RIVER POWER STATION, CENTRAL CITY., KY  
ASH TREATMENT BASIN #1 SITE PHOTOS

**CHK'D BY:** MGS

**REV. NO.:**

**PROJECT NO:** 3-2106-0177-0002

**PROJECTION:**

**SCALE:**

**PAGE NO.:** B-7

Note: Direction(s) in Photos from Plant North (Green River is South)





**M-13**

**LOOKING NE AT OUTLET STRUCTURE, PERIMETER SKIMMER AND POND INTERIOR TO NATURAL HILLSIDE IN BACKGROUND, STACK OF CONCRETE STOP LOGS IN FOREGROUND**



**M-14**

**LOOKING DOWN INTO INLET OF OUTLET STRUCTURE**

<b>AMEC Earth &amp; Environmental</b> 690 Commonwealth Center 11003 Bluegrass Parkway Louisville, Ky 40239 (502) 267-0700				<b>CLIENT LOGO</b> 		<b>CLIENT</b> <b>UNITED STATES ENVIRONMENTAL PROTECTION AGENCY</b>			
<b>PROJECT</b> ASSESSMENT OF DAM SAFETY OF COAL COMBUSTION SURFACE IMPOUNDMENTS				<b>DWN BY:</b> CAE		<b>DATUM:</b>		<b>DATE:</b> 8/19/10	
<b>TITLE</b> KENTUCKY UTILITIES, SUBSIDIARY OF E.ON U.S. GREEN RIVER POWER STATION, CENTRAL CITY., KY ASH TREATMENT BASIN #1 SITE PHOTOS				<b>CHK'D BY:</b> MGS		<b>REV. NO.:</b>		<b>PROJECT NO:</b> 3-2106-0177-0002	
				<b>PROJECTION:</b>		<b>SCALE:</b>		<b>PAGE NO.:</b> B-8	

Note: Direction(s) in Photos from Plant North (Green River is South)





**M-15**

LOOKING NW AT OUTLET STRUCTURE, PERIMETER SKIMMER AND POND INTERIOR TO NATURAL HILLSIDE IN BACKGROUND. STACK OF CONCRETE STOP LOGS IN FOREGROUND



**M-16**

LOOKING NE AT EAST END OF SOUTH DIKE AND POND INTERIOR, NATURAL GROUND IN BACKGROUND

<b>AMEC Earth &amp; Environmental</b> 890 Commonwealth Center 11003 Bluegrass Parkway Louisville, Ky 40239 (502) 267-0700				<b>CLIENT LOGO</b> 		<b>CLIENT</b> UNITED STATES ENVIRONMENTAL PROTECTION AGENCY			
<b>PROJECT</b> ASSESSMENT OF DAM SAFETY OF COAL COMBUSTION SURFACE IMPOUNDMENTS				<b>DWN BY:</b> CAE		<b>DATUM:</b>		<b>DATE:</b> 8/19/10	
<b>TITLE</b> KENTUCKY UTILITIES, SUBSIDIARY OF E.ON U.S. GREEN RIVER POWER STATION, CENTRAL CITY., KY ASH TREATMENT BASIN #1 SITE PHOTOS				<b>CHK'D BY:</b> MGS		<b>REV. NO.:</b>		<b>PROJECT NO:</b> 3-2106-0177-0002	
				<b>PROJECTION:</b>		<b>SCALE:</b>		<b>PAGE NO.:</b> B-9	

Note: Direction(s) in Photos from Plant North (Green River is South)



**M-17**

**LOOKING N AT EAST DIKE, PRIMARILY ORIGINAL GROUND ON EAST SIDE**



**M-18**

**LOOKING SE FROM EAST DIKE TOWARD PLANT**

**AMEC Earth & Environmental**

690 Commonwealth Center  
11003 Bluegrass Parkway  
Louisville, Ky 40239  
(502) 267-0700



CLIENT LOGO



CLIENT  
**UNITED STATES  
ENVIRONMENTAL  
PROTECTION AGENCY**

PROJECT  
**ASSESSMENT OF DAM SAFETY OF COAL COMBUSTION SURFACE IMPOUNDMENTS**

DWN BY: CAE

DATUM:

DATE: 8/19/10

TITLE  
**KENTUCKY UTILITIES, SUBSIDIARY OF E.ON U.S.  
GREEN RIVER POWER STATION, CENTRAL CITY., KY  
ASH TREATMENT BASIN #1 SITE PHOTOS**

CHK'D BY: MGS

REV. NO.:

PROJECT NO:  
3-2106-0177-0002

PROJECTION:

SCALE:

PAGE NO.:  
B-10



Note: Direction(s) in Photos from Plant North (Green River is South)





**M-19**

**TIE-IN OF NORTH END OF EAST DIKE TO ORIGINAL GROUND**



**M-20**

**GRAVEL AND SAND STOCKPILE AT NORTH END OF EAST DIKE. TREES APPEAR TO BE GROWING IN POND INTERIOR.  
TREES COULD BE GROWING ON FINGER OF ORIGINAL HILLSIDE**

<b>AMEC Earth &amp; Environmental</b> 690 Commonwealth Center 11003 Bluegrass Parkway Louisville, Ky 40239 (502) 267-0700				<b>CLIENT LOGO</b> 		<b>CLIENT</b> <b>UNITED STATES ENVIRONMENTAL PROTECTION AGENCY</b>	
<b>PROJECT</b> ASSESSMENT OF DAM SAFETY OF COAL COMBUSTION SURFACE IMPOUNDMENTS				<b>DWN BY:</b> CAE		<b>DATE:</b> 8/19/10	
<b>TITLE</b> KENTUCKY UTILITIES, SUBSIDIARY OF E.ON U.S. GREEN RIVER POWER STATION, CENTRAL CITY., KY ASH TREATMENT BASIN #1 SITE PHOTOS				<b>CHK'D BY:</b> MGS		<b>REV. NO.:</b>	
				<b>PROJECTION:</b>		<b>SCALE:</b>	
						<b>PROJECT NO:</b> 3-2106-0177-0002	
						<b>PAGE NO.:</b> B-11	

Note: Direction(s) in Photos from Plant North (Green River is South)



**M-21**

**EAST BUTTRESS AND DRAIN OUTLET ON SOUTH DIKE**



**M-22**

**PRINCIPAL OUTFALL AT TOE OF SOUTH DIKE,  
SOME EROSION ON OUTSIDE SIDEWALLS**

**AMEC Earth & Environmental**

690 Commonwealth Center  
11003 Bluegrass Parkway  
Louisville, Ky 40289  
(502) 267-0700



**CLIENT LOGO**



**CLIENT**

**UNITED STATES  
ENVIRONMENTAL  
PROTECTION AGENCY**

**PROJECT**  
ASSESSMENT OF DAM SAFETY OF COAL COMBUSTION SURFACE IMPOUNDMENTS

**DWN BY:** CAE

**DATUM:**

**DATE:** 8/19/10

**TITLE**  
KENTUCKY UTILITIES, SUBSIDIARY OF E.ON U.S.  
GREEN RIVER POWER STATION, CENTRAL CITY., KY  
ASH TREATMENT BASIN #1 SITE PHOTOS

**CHK'D BY:** MGS

**REV. NO.:**

**PROJECT NO:** 3-2106-0177-0002

**PROJECTION:**

**SCALE:**

**PAGE NO.:** B-12

Note: Direction(s) in Photos from Plant North (Green River is South)





**M-23**

**LOOKING EAST ON SOUTH DIKE, UNEVEN SLOPES AND SPARSE GRASS ON DOWNSTREAM SLOPE FROM WEST BUTTRESS TO ABOUT 300 FEET EAST**





**M-24**

**TOE DRAIN OUTLET FOR WEST BUTTRESS ON SOUTH DIKE**

<b>AMEC Earth &amp; Environmental</b> 690 Commonwealth Center 11003 Bluegrass Parkway Louisville, Ky 40289 (502) 267-0700				<b>CLIENT LOGO</b> 		<b>CLIENT</b> <b>UNITED STATES ENVIRONMENTAL PROTECTION AGENCY</b>	
<b>PROJECT</b> ASSESSMENT OF DAM SAFETY OF COAL COMBUSTION SURFACE IMPOUNDMENTS				<b>DWN BY:</b> CAE		<b>DATE:</b> 8/19/10	
<b>TITLE</b> KENTUCKY UTILITIES, SUBSIDIARY OF E.ON U.S. GREEN RIVER POWER STATION, CENTRAL CITY., KY ASH TREATMENT BASIN #1 SITE PHOTOS				<b>CHK'D BY:</b> MGS		<b>REV. NO.:</b>	
				<b>PROJECTION:</b>		<b>SCALE:</b>	
						<b>PROJECT NO:</b> 3-2106-0177-0002	
						<b>PAGE NO.:</b> B-13	



**M-25**  
**LOOKING NW AT SLUICE PIPES ON SOUTH DIKE**

<b>AMEC Earth &amp; Environmental</b> 690 Commonwealth Center 11003 Bluegrass Parkway Louisville, Ky 40239 (502) 267-0700				<b>CLIENT LOGO</b> 		<b>CLIENT</b> UNITED STATES ENVIRONMENTAL PROTECTION AGENCY			
<b>PROJECT</b> ASSESSMENT OF DAM SAFETY OF COAL COMBUSTION SURFACE IMPOUNDMENTS				<b>DWN BY:</b> CAE		<b>DATUM:</b>		<b>DATE:</b> 8/19/10	
<b>TITLE</b> KENTUCKY UTILITIES, SUBSIDIARY OF E.ON U.S. GREEN RIVER POWER STATION, CENTRAL CITY., KY ASH TREATMENT BASIN #1 SITE PHOTOS				<b>CHK'D BY:</b> MGS		<b>REV. NO.:</b>		<b>PROJECT NO:</b> 3-2106-0177-0002	
				<b>PROJECTION:</b>		<b>SCALE:</b>		<b>PAGE NO.:</b> B-14	



**CR-1**

**LOOKING W AT SOUTH DIKE (ROAD), EROSION, SPARSE GRASS, STEEP SLOPE**



**CR-2**

**LOOKING W AT SOUTH DIKE (ROAD), CREST AND UPSTREAM SLOPE**

**AMEC Earth & Environmental**

690 Commonwealth Center  
11003 Bluegrass Parkway  
Louisville, Ky 40239  
(502) 267-0700



**CLIENT LOGO**



**CLIENT**

**UNITED STATES ENVIRONMENTAL PROTECTION AGENCY**

**PROJECT**  
ASSESSMENT OF DAM SAFETY OF COAL COMBUSTION SURFACE IMPOUNDMENTS

**DWN BY:** CAE

**DATUM:**

**DATE:** 8/19/10

**TITLE**  
KENTUCKY UTILITIES, SUBSIDIARY OF E.ON U.S.  
GREEN RIVER GENERATING STATION, CENTRAL CITY., KY  
COAL RUN-OFF POND SITE PHOTOS

**CHK'D BY:** MGS

**REV. NO.:**

**PROJECT NO:** 3-2106-0177-0002

**PROJECTION:**

**SCALE:**

**PAGE NO.:** B-15



**CR-3**

**LOOKING N AT EAST DIKE (COMMON WITH ASH POND 2)**



**CR-4**

**LOOKING NW ON EAST DIKE, POND INTERIOR AND TIE-IN IN BACKGROUND**

**AMEC Earth & Environmental**

690 Commonwealth Center  
11003 Bluegrass Parkway  
Louisville, Ky 40299  
(502) 267-0700



**CLIENT LOGO**



**CLIENT**

**UNITED STATES ENVIRONMENTAL PROTECTION AGENCY**

**PROJECT**  
ASSESSMENT OF DAM SAFETY OF COAL COMBUSTION SURFACE IMPOUNDMENTS

**DWN BY:**  
CAE

**DATUM:**

**DATE:** 8/19/10

**TITLE**  
KENTUCKY UTILITIES, SUBSIDIARY OF E.ON U.S.  
GREEN RIVER GENERATING STATION, CENTRAL CITY., KY  
COAL RUN-OFF POND SITE PHOTOS

**CHK'D BY:**  
MGS

**REV. NO.:**

**PROJECT NO:**  
3-2106-0177-0002

**PROJECTION:**

**SCALE:**

**PAGE NO.:**  
B-16





**CR-5**

LOOKING W FROM EAST DIKE, POND INTERIOR AT NORTH END, WEST BERM AT COAL PILE



**CR-6**

LOOKING S FROM NORTH END OF EAST DIKE (COMMON WITH ASH POND 2),  
DOWNSTREAM SLOPE (=UPSTREAM SLOPE AP 2)



<b>AMEC Earth &amp; Environmental</b> 890 Commonwealth Center 11003 Bluegrass Parkway Louisville, Ky 40299 (502) 267-0700				CLIENT LOGO 		CLIENT <b>UNITED STATES ENVIRONMENTAL PROTECTION AGENCY</b>			
PROJECT <b>ASSESSMENT OF DAM SAFETY OF COAL COMBUSTION SURFACE IMPOUNDMENTS</b>				DWN BY: CAE		DATUM:		DATE: 8/19/10	
TITLE <b>KENTUCKY UTILITIES, SUBSIDIARY OF E.ON U.S.                  GREEN RIVER GENERATING STATION, CENTRAL CITY., KY                  COAL RUN-OFF POND SITE PHOTOS</b>				CHK'D BY: MGS		REV. NO.:		PROJECT NO: 3-2108-0177-0002	
				PROJECTION:		SCALE:		PAGE NO.: B-17	



**CR-7**  
**METAL AND BOOM SKIMMER AND CMP PIPE INLET AT NORTH END OF EAST DIKE**



**CR-8**  
**CMP PIPE OUTLET TO ASH POND 2**

<b>AMEC Earth &amp; Environmental</b> 690 Commonwealth Center 11003 Bluegrass Parkway Louisville, Ky 40299 (502) 267-0700				<b>CLIENT LOGO</b> 		<b>CLIENT</b> UNITED STATES ENVIRONMENTAL PROTECTION AGENCY	
<b>PROJECT</b> ASSESSMENT OF DAM SAFETY OF COAL COMBUSTION SURFACE IMPOUNDMENTS				<b>DWN BY:</b> CAE		<b>DATE:</b> 8/19/10	
<b>TITLE</b> KENTUCKY UTILITIES, SUBSIDIARY OF E.ON U.S. GREEN RIVER GENERATING STATION, CENTRAL CITY., KY COAL RUN-OFF POND SITE PHOTOS				<b>CHK'D BY:</b> MGS		<b>PROJECT NO.:</b> 3-2106-0177-0002	
				<b>PROJECTION:</b>		<b>SCALE:</b>	
						<b>PAGE NO.:</b> B-18	





**CR-9**

**LOOKING SW FROM EAST DIKE AT POND INTERIOR (ABOUT 50% WATER)**



**CR-10**

**LOOKING N FROM EAST DIKE AT TIE-IN**

**AMEC Earth & Environmental**

690 Commonwealth Center  
11003 Bluegrass Parkway  
Louisville, Ky 40299  
(502) 267-0700



**CLIENT LOGO**



**CLIENT**

**UNITED STATES  
ENVIRONMENTAL  
PROTECTION AGENCY**

<b>PROJECT</b> ASSESSMENT OF DAM SAFETY OF COAL COMBUSTION SURFACE IMPOUNDMENTS  <b>TITLE</b> KENTUCKY UTILITIES, SUBSIDIARY OF E.ON U.S. GREEN RIVER GENERATING STATION, CENTRAL CITY., KY COAL RUN-OFF POND SITE PHOTOS	<b>DWN BY:</b> CAE	<b>DATUM:</b>	<b>DATE:</b> 8/19/10
	<b>CHK'D BY:</b> MGS	<b>REV. NO.:</b>	<b>PROJECT NO:</b> 3-2106-0177-0002
<b>PROJECTION:</b>	<b>SCALE:</b>	<b>PAGE NO.:</b> B-19	





**2-1**

**LOOKING E FROM WEST CORNER AT SOUTH DIKE (ROAD?), UPSTREAM SLOPE AND CREST, MOUND TO NORTH**



**2-2**

**LOOKING NE ON SOUTH DIKE, ASH ABOVE LEVEL OF ROAD, TREES IN INTERIOR**

<b>AMEC Earth &amp; Environmental</b> 690 Commonwealth Center 11003 Bluegrass Parkway Louisville, Ky 40299 (502) 267-0700				<b>CLIENT LOGO</b> 		<b>CLIENT</b> UNITED STATES ENVIRONMENTAL PROTECTION AGENCY	
<b>PROJECT</b> ASSESSMENT OF DAM SAFETY OF COAL COMBUSTION SURFACE IMPOUNDMENTS				<b>DWN BY:</b> CAE		<b>DATE:</b> 8/19/10	
<b>TITLE</b> KENTUCKY UTILITIES, SUBSIDIARY OF E.ON U.S. GREEN RIVER GENERATING STATION, CENTRAL CITY, KY ASH TREATMENT BASIN #2 SITE PHOTOS				<b>CHK'D BY:</b> MGS		<b>REV. NO.:</b>	
				<b>PROJECTION:</b>		<b>SCALE:</b>	
						<b>PROJECT NO:</b> 3-2106-0177-0002 <b>PAGE NO.:</b> B-20	



08/16/2010

2-3



LOOKING E AT RIP-RAP ON DOWNSTREAM SLOPE OF ROAD (SOUTH DIKE?), STEEP SLOPE



08/16/2010

2-4

LOOKING W AT DOWNSTREAM SLOPE OF ROAD (SOUTH DIKE?), STEEP SLOPE AND SPARSE GRASS

<b>AMEC Earth &amp; Environmental</b> 690 Commonwealth Center 11003 Bluegrass Parkway Louisville, Ky 40299 (502) 267-0700				<b>CLIENT LOGO</b> 		<b>CLIENT</b> UNITED STATES ENVIRONMENTAL PROTECTION AGENCY	
<b>PROJECT</b> ASSESSMENT OF DAM SAFETY OF COAL COMBUSTION SURFACE IMPOUNDMENTS				<b>DWN BY:</b> CAE		<b>DATE:</b> 8/19/10	
<b>TITLE</b> KENTUCKY UTILITIES, SUBSIDIARY OF E.ON U.S. GREEN RIVER GENERATING STATION, CENTRAL CITY, KY ASH TREATMENT BASIN #2 SITE PHOTOS				<b>CHK'D BY:</b> MGS		<b>REVISIONS:</b>	
				<b>PROJECTION:</b>		<b>SCALE:</b>	
						<b>PAGE NO.:</b> B-21	



Note: Direction(s) in Photos from Plant North (Green River is South)



**2-5**  
NEW PZ ON ROAD, SOUTH DIKE



**2-6**  
LOOKING SE FROM SOUTHEAST CORNER OF POND, ELEVATED PIPE LINES TO SCRUBBER POND,  
SITE DISCHARGE DITCH ON LEFT, PORTION OF FORMER ASH POND 3 ON RIGHT

<b>AMEC Earth &amp; Environmental</b> 890 Commonwealth Center 11003 Bluegrass Parkway Louisville, Ky 40299 (502) 267-0700				CLIENT LOGO 		CLIENT <b>UNITED STATES ENVIRONMENTAL PROTECTION AGENCY</b>			
PROJECT ASSESSMENT OF DAM SAFETY OF COAL COMBUSTION SURFACE IMPOUNDMENTS				DWN BY: CAE		DATUM:		DATE: 8/19/10	
TITLE KENTUCKY UTILITIES, SUBSIDIARY OF E.ON U.S. GREEN RIVER GENERATING STATION, CENTRAL CITY, KY ASH TREATMENT BASIN #2 SITE PHOTOS				CHK'D BY: MGS		REV. NO.:		PROJECT NO: 3-2106-0177-0002	
				PROJECTION:		SCALE:		PAGE NO.: B-22	



**2-7**

**LOOKING S FROM PHOTO 2-6 AT FORMER ASH POND 3**



**2-8**

**LOOKING N AT CREST AND UPSTREAM SLOPE OF EAST DIKE**

**AMEC Earth & Environmental**

690 Commonwealth Center  
11003 Bluegrass Parkway  
Louisville, Ky 40299  
(502) 267-0700



**CLIENT LOGO**



**CLIENT**

**UNITED STATES  
ENVIRONMENTAL  
PROTECTION AGENCY**

**PROJECT**  
ASSESSMENT OF DAM SAFETY OF COAL COMBUSTION SURFACE IMPOUNDMENTS

**DWN BY:** CAE

**DATUM:**

**DATE:** 8/19/10

**TITLE**  
KENTUCKY UTILITIES, SUBSIDIARY OF E.ON U.S.  
GREEN RIVER GENERATING STATION, CENTRAL CITY, KY  
ASH TREATMENT BASIN #2 SITE PHOTOS

**CHK'D BY:** MGS

**REV. NO.:**

**PROJECT NO:**  
3-2106-0177-0002

**PROJECTION:**

**SCALE:**

**PAGE NO.:**  
B-23



**2-9**

**LOOKING N AT DOWNSTREAM SLOPE OF EAST DIKE**



**2-10**

**LOOKING N AT CREST OF EAST DIKE, FOREGROUND: NEW PZ IN ROAD  
BACKGROUND: OUTLET WORKS AND TIE-IN TO NATURAL GROUND**

**AMEC Earth & Environmental**

690 Commonwealth Center  
11003 Bluegrass Parkway  
Louisville, Ky 40299  
(502) 267-0700



**CLIENT LOGO**



**CLIENT**

**UNITED STATES  
ENVIRONMENTAL  
PROTECTION AGENCY**

**PROJECT**  
ASSESSMENT OF DAM SAFETY OF COAL COMBUSTION SURFACE IMPOUNDMENTS

**DWN BY:** CAE

**DATUM:**

**DATE:** 8/19/10

**TITLE**  
KENTUCKY UTILITIES, SUBSIDIARY OF E.ON U.S.  
GREEN RIVER GENERATING STATION, CENTRAL CITY, KY  
ASH TREATMENT BASIN #2 SITE PHOTOS

**CHK'D BY:** MGS

**REV. NO.:**

**PROJECT NO:**  
3-2106-0177-0002

**PROJECTION:**

**SCALE:**

**PAGE NO.:**  
B-24



**2-11**

**LOOKING SW FROM NORTHEAST CORNER OF POND AT OUTLET STRUCTURE, CONTROLS AND POND INTERIOR**



**2-12**

**METAL AND RUBBER SKIMMER AND INTAKE, SILT CLEANED APPROX. EVERY 5 YEARS**





**2-13**

**LOOKING SW AT NPDES OUTFALL 001, BACKGROUND: SPARSE GRASS ON DOWNSTREAM SLOPE OF SCRUBBER POND WEST DIKE**



**2-14**

**LOOKING NE AT NPDES OUTFALL 001, OVERFLOW AND GROUDED CHANNEL**

<b>AMEC Earth &amp; Environmental</b> 690 Commonwealth Center 11003 Bluegrass Parkway Louisville, Ky 40299 (502) 267-0700				<b>CLIENT LOGO</b> 		<b>CLIENT</b> UNITED STATES ENVIRONMENTAL PROTECTION AGENCY	
<b>PROJECT</b> ASSESSMENT OF DAM SAFETY OF COAL COMBUSTION SURFACE IMPOUNDMENTS				<b>DWN BY:</b> CAE		<b>DATE:</b> 8/19/10	
<b>TITLE</b> KENTUCKY UTILITIES, SUBSIDIARY OF E.ON U.S. GREEN RIVER GENERATING STATION, CENTRAL CITY, KY ASH TREATMENT BASIN #2 SITE PHOTOS				<b>CHK'D BY:</b> MGS		<b>REV. NO.:</b>	
				<b>PROJECTION:</b>		<b>SCALE:</b>	
						<b>PROJECT NO:</b> 3-2106-0177-0002 <b>PAGE NO.:</b> B-26	







**2-15**

**LOOKING N AT EAST TIE-IN TO NATURAL GROUND, BACKGROUND: EAST BUTTRESS ON MAIN POND SOUTH DIKE**



**2-16**

**LOOKING SOUTH AT LEFT: DOWNSTREAM SLOPE WEST DIKE SCRUBBER POND, CENTER: SITE OUTLET DITCH, RIGHT: DOWNSTREAM SLOPE EAST DIKE ASH POND 2**

<b>AMEC Earth &amp; Environmental</b> 890 Commonwealth Center 11003 Bluegrass Parkway Louisville, Ky 40299 (502) 267-0700				<b>CLIENT LOGO</b> 		<b>CLIENT</b> UNITED STATES ENVIRONMENTAL PROTECTION AGENCY	
<b>PROJECT</b> ASSESSMENT OF DAM SAFETY OF COAL COMBUSTION SURFACE IMPOUNDMENTS				<b>DWN BY:</b> CAE		<b>DATE:</b> 8/19/10	
<b>TITLE</b> KENTUCKY UTILITIES, SUBSIDIARY OF E.ON U.S. GREEN RIVER GENERATING STATION, CENTRAL CITY, KY ASH TREATMENT BASIN #2 SITE PHOTOS				<b>CHK'D BY:</b> MGS		<b>REVISIONS:</b>	
				<b>PROJECTION:</b>		<b>SCALE:</b>	
						<b>PROJECT NO:</b> 3-2106-0177-0002 <b>PAGE NO.:</b> B-27	



**SP-1**

**LOOKING S AT CREST AND UPSTREAM SLOPE OF WEST DIKE, HEIGHT OF INTERIOR AREAS OF ASH UP TO WITHIN 1-FOOT OF CREST**



**SP-2**

**LOOKING W AT CREST AND UPSTREAM SLOPE OF NORTH DIKE, INTERIOR AREAS OF ASH AND PILED MATERIAL ABOVE CREST**

**AMEC Earth & Environmental**

690 Commonwealth Center  
11003 Bluegrass Parkway  
Louisville, Ky 40239  
(502) 267-0700



**CLIENT LOGO**



**CLIENT**

**UNITED STATES ENVIRONMENTAL PROTECTION AGENCY**

**PROJECT**  
ASSESSMENT OF DAM SAFETY OF COAL COMBUSTION SURFACE IMPOUNDMENTS

**DWN BY:** CAE

**DATUM:**

**DATE:** 8/19/10

**TITLE**  
KENTUCKY UTILITIES, SUBSIDIARY OF E.ON U.S.  
GREEN RIVER GENERATING STATION, CENTRAL CITY, KY  
SCRUBBER POND SITE PHOTOS

**CHK'D BY:** MGS

**REV. NO.:**

**PROJECT NO:** 3-2106-0177-0002

**PROJECTION:**

**SCALE:**

**PAGE NO.:** B-28





**SP-3**

LOOKING S AT CREST AND UPSTREAM SLOPE OF WEST DIKE, PUMP STATION AT SOUTHWEST CORNER



**SP-4**

LOOKING NE FROM SOUTHWEST CORNER AT POND INTERIOR, APPROXIMATELY 50% WATER

<b>AMEC Earth &amp; Environmental</b> 690 Commonwealth Center 11003 Bluegrass Parkway Louisville, Ky 40299 (502) 267-0700				<b>CLIENT LOGO</b> 		<b>CLIENT</b> UNITED STATES ENVIRONMENTAL PROTECTION AGENCY	
<b>PROJECT</b> ASSESSMENT OF DAM SAFETY OF COAL COMBUSTION SURFACE IMPOUNDMENTS				<b>DWN BY:</b> CAE		<b>DATE:</b> 8/19/10	
<b>TITLE</b> KENTUCKY UTILITIES, SUBSIDIARY OF E.ON U.S. GREEN RIVER GENERATING STATION, CENTRAL CITY, KY SCRUBBER POND SITE PHOTOS				<b>CHK'D BY:</b> MGS		<b>PROJECT NO:</b> 3-2108-0177-0002	
				<b>PROJECTION:</b>		<b>SCALE:</b>	
						<b>PAGE NO.:</b> B-29	





**SP-5**

**LOOKING E AT CREST AND UPSTREAM SLOPE OF SOUTH DIKE, NEW PZ IN CREST, AREAS WITH UNEVEN TO NEAR VERTICAL SLOPES ON UPSTREAM SLOPE ON SOUTH AND EAST DIKE**



**SP-6**

**LOOKING N FROM SOUTHEAST CORNER AT CREST AND UPSTREAM SLOPE OF EAST DIKE, AREAS WITH UNEVEN TO NEAR VERTICAL SLOPES ON UPSTREAM SLOPE**

<b>AMEC Earth &amp; Environmental</b> 890 Commonwealth Center 11003 Bluegrass Parkway Louisville, Ky 40299 (502) 267-0700				<b>CLIENT LOGO</b> 		<b>CLIENT</b> UNITED STATES ENVIRONMENTAL PROTECTION AGENCY	
<b>PROJECT</b> ASSESSMENT OF DAM SAFETY OF COAL COMBUSTION SURFACE IMPOUNDMENTS				<b>DWN BY:</b> CAE		<b>DATE:</b> 8/19/10	
<b>TITLE</b> KENTUCKY UTILITIES, SUBSIDIARY OF E.ON U.S. GREEN RIVER GENERATING STATION, CENTRAL CITY, KY SCRUBBER POND SITE PHOTOS				<b>CHK'D BY:</b> MGS		<b>PROJECT NO.:</b> 3-2108-0177-0002	
				<b>PROJECTION:</b>		<b>SCALE:</b>	
						<b>PAGE NO.:</b> B-30	



**SP-7**

LOOKING W FROM NORTH DIKE AT NORTHWEST CORNER OF POND, NATURAL GROUND ON DOWNSTREAM SIDE



**SP-8**

LOOKING W AT EAST DIKE DOWNSTREAM SLOPE, STEEP AND AREAS WITH SPARSE VEGETATION

**AMEC Earth & Environmental**

690 Commonwealth Center  
11003 Bluegrass Parkway  
Louisville, Ky 40299  
(502) 267-0700



CLIENT LOGO



CLIENT

**UNITED STATES  
ENVIRONMENTAL  
PROTECTION AGENCY**

PROJECT  
ASSESSMENT OF DAM SAFETY OF COAL COMBUSTION SURFACE IMPOUNDMENTS

DWN BY: CAE

DATUM:

DATE: 8/19/10

TITLE  
KENTUCKY UTILITIES, SUBSIDIARY OF E.ON U.S.  
GREEN RIVER GENERATING STATION, CENTRAL CITY, KY  
SCRUBBER POND SITE PHOTOS

CHK'D BY: MGS

REV. NO.:

PROJECT NO: 3-2106-0177-0002

PROJECTION:

SCALE:

PAGE NO.: B-31





**SP-9**

**LOOKING SOUTH FROM NEAR SOUTHEAST CORNER TOWARD FORMER ASH POND 3**



**SP-10**

**LOOKING SE AT SOUTHWEST CORNER DOWNSTREAM SLOPE, SHALLOW SURFACE SLIDE REPAIR**

<b>AMEC Earth &amp; Environmental</b> 690 Commonwealth Center 11003 Bluegrass Parkway Louisville, Ky 40299 (502) 267-0700				<b>CLIENT LOGO</b> 		<b>CLIENT</b> UNITED STATES ENVIRONMENTAL PROTECTION AGENCY	
<b>PROJECT</b> ASSESSMENT OF DAM SAFETY OF COAL COMBUSTION SURFACE IMPOUNDMENTS				<b>DWN BY:</b> CAE		<b>DATE:</b> 8/19/10	
<b>TITLE</b> KENTUCKY UTILITIES, SUBSIDIARY OF E.ON U.S. GREEN RIVER GENERATING STATION, CENTRAL CITY, KY SCRUBBER POND SITE PHOTOS				<b>CHK'D BY:</b> MGS		<b>REVISION:</b>	
				<b>PROJECTION:</b>		<b>SCALE:</b>	
						<b>PROJECT NO:</b> 3-2106-0177-0002 <b>PAGE NO.:</b> B-32	



**SP-11**

**LOOKING E AT DOWNSTREAM SLOPE OF SOUTH DIKE, WET AREA BELOW TOE, STEEP SLOPE, SPARSE GRASS**



**SP-12**

**LOOKING NE AT DOWNSTREAM SLOPE OF SOUTH DIKE, STEEP SLOPE, SPARSE GRASS**

**AMEC Earth & Environmental**

690 Commonwealth Center  
11003 Bluegrass Parkway  
Louisville, Ky 40299  
(502) 267-0700



**CLIENT LOGO**



**CLIENT**



**UNITED STATES ENVIRONMENTAL PROTECTION AGENCY**

<b>PROJECT</b> ASSESSMENT OF DAM SAFETY OF COAL COMBUSTION SURFACE IMPOUNDMENTS  <b>TITLE</b> KENTUCKY UTILITIES, SUBSIDIARY OF E.ON U.S. GREEN RIVER GENERATING STATION, CENTRAL CITY, KY SCRUBBER POND SITE PHOTOS	<b>DWN BY:</b> CAE	<b>DATUM:</b>	<b>DATE:</b> 8/19/10
	<b>CHK'D BY:</b> MGS	<b>REV. NO.:</b>	<b>PROJECT NO:</b> 3-2106-0177-0002
	<b>PROJECTION:</b>	<b>SCALE:</b>	<b>PAGE NO.:</b> B-33



**SP-13**

**LOOKING N AT DOWNSTREAM SLOPE EAST DIKE, STEEP SLOPE, AREAS OF SPARSE GRASS, TIE INTO ORIGINAL IN BACKGROUND**

<b>AMEC Earth &amp; Environmental</b> 690 Commonwealth Center 11003 Bluegrass Parkway Louisville, Ky 40299 (502) 267-0700				<b>CLIENT LOGO</b> 		<b>CLIENT</b> UNITED STATES ENVIRONMENTAL PROTECTION AGENCY	
<b>PROJECT</b> ASSESSMENT OF DAM SAFETY OF COAL COMBUSTION SURFACE IMPOUNDMENTS				<b>DWN BY:</b> CAE		<b>DATE:</b> 8/19/10	
<b>TITLE</b> KENTUCKY UTILITIES, SUBSIDIARY OF E.ON U.S. GREEN RIVER GENERATING STATION, CENTRAL CITY, KY SCRUBBER POND SITE PHOTOS				<b>CHK'D BY:</b> MGS		<b>REV. NO.:</b>	
				<b>PROJECTION:</b>		<b>SCALE:</b>	
						<b>PROJECT NO:</b> 3-2106-0177-0002 <b>PAGE NO.:</b> B-34	







**3-1**

**CULVERT AND OUTLET DITCH TO GREEN RIVER WEST OF ASH POND 3**



**3-2**



**LOOKING S FROM PHOTO 2-6 AT ASH POND 3**

<b>AMEC Earth &amp; Environmental</b> 690 Commonwealth Center 11003 Bluegrass Parkway Louisville, Ky 40299 (502) 267-0700				<b>CLIENT LOGO</b> 		<b>CLIENT</b> UNITED STATES ENVIRONMENTAL PROTECTION AGENCY	
<b>PROJECT</b> ASSESSMENT OF DAM SAFETY OF COAL COMBUSTION SURFACE IMPOUNDMENTS				<b>DWN BY:</b> CAE		<b>DATE:</b> 8/19/10	
<b>TITLE</b> KENTUCKY UTILITIES, SUBSIDIARY OF E.ON U.S. GREEN RIVER GENERATING STATION, CENTRAL CITY, KY ASH POND 3 SITE PHOTOS				<b>CHK'D BY:</b> MGS		<b>REV. NO.:</b>	
				<b>PROJECTION:</b>		<b>SCALE:</b>	
						<b>PROJECT NO:</b> 3-2106-0177-0002 <b>PAGE NO.:</b> B-35	



**3-3**

**REGRADED AND RIP-RAP ARMORED SOUTH AND ONLY DIKE OF ASH POND 3**

<b>AMEC Earth &amp; Environmental</b> 690 Commonwealth Center 11003 Bluegrass Parkway Louisville, Ky 40299 (502) 267-0700				<b>CLIENT LOGO</b> 		<b>CLIENT</b> UNITED STATES ENVIRONMENTAL PROTECTION AGENCY			
<b>PROJECT</b> ASSESSMENT OF DAM SAFETY OF COAL COMBUSTION SURFACE IMPOUNDMENTS				<b>DWN BY:</b> CAE		<b>DATUM:</b>		<b>DATE:</b> 8/19/10	
<b>TITLE</b> KENTUCKY UTILITIES, SUBSIDIARY OF E.ON U.S. GREEN RIVER GENERATING STATION, CENTRAL CITY, KY SCRUBBER POND SITE PHOTOS				<b>CHK'D BY:</b> MGS		<b>REV. NO.:</b>		<b>PROJECT NO:</b> 3-2106-0177-0002	
				<b>PROJECTION:</b>		<b>SCALE:</b>		<b>PAGE NO.:</b> B-36	

**APPENDIX C**  
**Inventory of Provided Materials**

**Kentucky Utilities, Subsidiary of E.ON U.S.  
Green River Power Station  
List of Provided Documents**

**8-18-10**

- 1 KU Green River Topographic Map.zip
- 2 KU Green River Main Ash Pond Slope Stability Analysis.pdf
- 3 KU Green River Scrubber Pond Drawings.zip
- 4 KU Green River Main Ash Pond Drawings.zip
- 5 KU Green River Appendix D Green River.pdf
- 6 KPDES Water Balance Diagrams.zip

**8-23-10**

- 1 H.C. Nutting Company – 1976 Report GEOTECH Investigation.pdf
- 2 H.C. Nutting Company – 1976 Report GEOTECH Investigation.pdf
- 3 H.C. Nutting Company – Retention Basin Tech Spec.zip
- 4 Sheet C-0001 General Site Plan – Water Pollution Control Facilities – RevC.pdf
- 5 Sheet C-0002 Plant and Switchyard Area Plan – Water Pollution Control Facilities – RevF.pdf
- 6 Sheet S-0416 Flow Measurement Structure – Plan and Sections-Water Pollution Control Facilities – RevC.pdf
- 7 Green River Ash Pond Slope Repair 2010.zip
- 8 Green River Spillways Report 12 August2010.pdf
- 9 Sheet GRO-SK-00004-GR 30x42 DRAINAGE.pdf

**8-25-10**

- 1 Boring Location Plan – Sheet S0<sub>2</sub> Removal Pond.pdf
- 2 Dike Location Plan – Sheet S0<sub>2</sub> Removal Pond.pdf
- 3 Green River Station August 2010 Pond Inspection Reports.pdf
- 4 Soil Boring Logs – Sheet S0<sub>2</sub> Removal Pond.pdf

**8-27-10**

- 1 Green River ATBs and FGD Basin 08-27-10.pdf

**9-3-10**

- 1 2010-09-03 Green River Data Package.pdf – Geotechnical Exploration and Slope Stability Analyses Data Package for Green River Power Station Number 2 Pond & Scrubber Pond, prepared by MACTEC Engineering and Consulting, Inc. , September 3, 2010

**9-10-10**

- 1 Response of Louisville Gas and Electric Company and Kentucky Utilities Company to Request for Information under Section 104(e) of the CERCLA

**Additional Provided Documents (provided as a response to September 2010 Green River Generating Station Draft Report to EPA)**

1. Kentucky Utilities Comments on DRAFT Report of Geotechnical Investigation Dam Safety Assessment of Coal Combustion Surface Impoundments Kentucky Utilities, A Subsidiary of E.ON U.S. Green River Station, Central City, Kentucky, dated January 26, 2011, including following Attachments 1 through 5:

Attachment 1 – KU's Comments - clerical and technical corrections to *DRAFT Report of Geotechnical Investigation Dam Safety Assessment of Coal Combustion Surface Impoundments Kentucky Utilities, a Subsidiary of E.ON U.S. Green River Station, Central City, Kentucky*

Attachment 2 - *Report of Geotechnical Exploration and Slope Stability Analyses Kentucky Utilities (KU) Green River Power Station, No. 2 Pond/Coal Pile Runoff Pond and Scrubber Pond, South Carrollton, Muhlenberg County, Kentucky, December 3, 2010, Mactec Engineering and Consulting, Inc.*  
*Addendum A, Report of Geotechnical Exploration and Slope Stability Analyses Kentucky Utilities (KU) Green River Power Station, No. 2 Pond/Coal Pile Runoff Pond and Scrubber Pond, South Carrollton, Muhlenberg County, Kentucky, January 24, 2011, Mactec Engineering and Consulting, Inc.*

*Sheet Number 1, As-Built, Number 2 Pond Slope Armoring and Ditch Relocation, September 15, 2010, Associated Engineers, Inc.*

Attachment 3 – *Addendum A - Assessment of Spillway Hydrologic Adequacy for the Coal Pile Pond, Ash Treatment Basin No. 2, and Scrubber Pond at Green River Generating Station, January 25, 2011, Mactec Engineering and Consulting, Inc.*

Attachment 4 – *Addendum A – Final Geotechnical Report, Main Ash Pond Slope Stability Analysis and Repair, Kentucky Utilities, Green River Station, January 24, 2011, Associated Engineers, Inc.*

Attachment 5 – Cover Pages, cover letter, appendices A and B of *2011 Pond Inspections Visual Site Assessment Report Six Impoundment Facilities, January 25, 2011, ATC Associates, Inc.*

2. KDEP Comments DRAFT Report of Geotechnical Investigation Dam Safety Assessment of Coal Combustion Surface Impoundments Kentucky Utilities, A Subsidiary of E.ON U.S., Green River Station, Central City, Tyrone, and Pineville KY AMEC Project No. 3-2106-0177-0002
3. Kentucky Energy and Environment Cabinet Department for Environmental Protection Division of Water Cover Letter, dated January 25, 2011 and Certificate of Inspection for Dam and Appurtenant Works for Green River Power Station Main Dam (ATB#1), dated January 5, 2011
4. Kentucky Energy and Environment Cabinet Department for Environmental Protection Division of Water Cover Letter, dated January 26, 2011 and Certificate of Inspection for Dam and Appurtenant Works for Green River Power Station Scrubber [Pond], dated January 5, 2011