

METHOD 9020A

TOTAL ORGANIC HALIDES (TOX)

1.0 SCOPE AND APPLICATION

1.1 Method 9020 determines Total Organic Halides (TOX) as chloride in drinking water and ground waters. The method uses carbon adsorption with a microcoulometric-titration detector.

1.2 Method 9020 detects all organic halides containing chlorine, bromine, and iodine that are adsorbed by granular activated carbon under the conditions of the method. Fluorine-containing species are not determined by this method.

1.3 Method 9020 is applicable to samples whose inorganic-halide concentration does not exceed the organic-halide concentration by more than 20,000 times.

1.4 Method 9020 does not measure TOX of compounds adsorbed to undissolved solids.

1.5 Method 9020 is restricted to use by, or under the supervision of, analysts experienced in the operation of a pyrolysis/microcoulometer and in the interpretation of the results.

1.6 This method is provided as a recommended procedure. It may be used as a reference for comparing the suitability of other methods thought to be appropriate for measurement of TOX (*i.e.*, by comparison of sensitivity, accuracy, and precision of data). There are three instruments that can be used to carry out this method. They are the TOX-10 available from Cosa Instruments, and the DX-20 and DX-20A available from Xertex-Dohrmann Instruments.

2.0 SUMMARY OF METHOD

2.1 A sample of water that has been protected against the loss of volatiles by the elimination of headspace in the sampling container, and that is free of undissolved solids, is passed through a column containing 40 mg of activated carbon. The column is washed to remove any trapped inorganic halides and is then combusted to convert the adsorbed organohalides to HX, which is trapped and titrated electrolytically using a microcoulometric detector.

3.0 INTERFERENCES

3.1 Method interferences may be caused by contaminants, reagents, glassware, and other sample-processing hardware. All these materials must be routinely demonstrated to be free from interferences under the conditions of the analysis by running method blanks.

3.1.1 Glassware must be scrupulously cleaned. Clean all glassware as soon as possible after use by treating with chromate cleaning solution. This should be followed by detergent washing in hot water. Rinse with tap water and distilled water and drain dry; glassware which is

not volumetric should, in addition, be heated in a muffle furnace at 400°C for 15 to 30 min. (Volumetric ware should not be heated in a muffle furnace.) Glassware should be sealed and stored in a clean environment after drying and cooling to prevent any accumulation of dust or other contaminants.

3.1.2 The use of high-purity reagents and gases helps to minimize interference problems.

3.2 Purity of the activated carbon must be verified before use. Only carbon samples that register less than 1,000 ng Cl⁻/40 mg should be used. The stock of activated carbon should be stored in its granular form in a glass container with a Teflon seal. Exposure to the air must be minimized, especially during and after milling and sieving the activated carbon. No more than a 2-wk supply should be prepared in advance. Protect carbon at all times from all sources of halogenated organic vapors. Store prepared carbon and packed columns in glass containers with Teflon seals.

3.3 Particulate matter will prevent the passage of the sample through the adsorption column. Particulates must, therefore, be eliminated from the sample. This must be done as gently as possible, with the least possible sample manipulation, in order to minimize the loss of volatiles. It should also be noted that the measured TOX will be biased by the exclusion of TOX from compounds adsorbed onto the particulates. The following techniques may be used to remove particulates; however, data users must be informed of the techniques used and their possible effects on the data. These techniques are listed in order of preference:

3.3.1 Allow the particulates to settle in the sample container and decant the supernatant liquid into the adsorption system.

3.3.2 Centrifuge sample and decant the supernatant liquid into the adsorption system.

3.3.3 Measure Purgeable Organic Halides (POX) of sample (see SW-846 Method 9021) and Non-Purgeable Organic Halides (NPOX, that is, TOX of sample that has been purged of volatiles) separately, where the NPOX sample is centrifuged or filtered.

4.0 APPARATUS AND MATERIALS

4.1 Adsorption system (a schematic diagram of the adsorption system is shown in Figure 1):

4.1.1 Adsorption module: Pressurized sample and nitrate-wash reservoirs. (There are three instruments known to EPA at this time that can be used to carry out this method. They are the TOX-10, available from Cosa Instruments, and the DX-20 and DX-20A, available from Xertex-Dohrmann Instruments.)

4.1.2 Adsorption columns: Pyrex, 5-cm-long x 6-mm-O.D. x 2-mm-I.D.

4.1.3 Granular activated carbon (GAC): Filtrasorb-400, Calgon-APC or equivalent, ground or milled, and screened to a 100/200 mesh range. Upon combustion of 40 mg of GAC, the apparent halide background should be 1,000 ng Cl⁻ equivalent or less.

4.1.4 Cerafelt (available from Johns-Manville) or equivalent: Form this material into plugs to fit the adsorption module and to hold 40 mg of GAC in the adsorption columns.

CAUTION: Do not touch this material with your fingers. Oily residue will contaminate carbon.

4.1.5 Column holders.

4.1.6 Class A volumetric flasks: 100-mL and 50-mL.

4.2 Analytical system:

4.2.1 Microcoulometric-titration system: Containing the following components (a flowchart of the analytical system is shown in Figure 2):

4.2.1.1 Boat sampler: Muffled at 800°C for at least 2-4 min and cleaned of any residue by vacuuming after each run.

4.2.1.2 Pyrolysis furnace.

4.2.1.3 Microcoulometer with integrator.

4.2.1.4 Titration cell.

4.2.2 Strip-chart recorder.

5.0 REAGENTS

5.1 Reagent grade chemicals shall be used in all tests. Unless otherwise indicated, it is intended that all reagents shall conform to the specifications of the Committee on Analytical Reagents of the American Chemical Society, where such specifications are available. Other grades may be used, provided it is first ascertained that the reagent is of sufficiently high purity to permit its use without lessening the accuracy of the determination.

5.2 Reagent water. All references to water in this method refer to reagent water, as defined in Chapter One.

5.3 Sodium sulfite (0.1 M), Na₂SO₃: Dissolve 12.6 g ACS reagent grade Na₂SO₃ in reagent water and dilute to 1 L.

5.4 Concentrated nitric acid (HNO₃).

5.5 Nitrate-wash solution (5,000 mg NO₃⁻/L), KNO₃: Prepare a nitrate-wash solution by transferring approximately 8.2 g of potassium nitrate (KNO₃) into a 1-liter Class A volumetric flask and diluting to volume with reagent water.

5.6 Carbon dioxide (CO₂): Gas, 99.9% purity.

5.7 Oxygen (O₂): 99.9% purity.

5.8 Nitrogen (N₂): Prepurified.

5.9 Acetic acid in water (70%), C₂H₄O₂: Dilute 7 volumes of glacial acetic acid with 3 volumes of reagent water.

5.10 Trichlorophenol solution, stock (1 μL = 10 μg Cl⁻): Prepare a stock solution by accurately weighing accurately 1.856 g of trichlorophenol into a 100-mL Class A volumetric flask. Dilute to volume with methanol.

5.11 Trichlorophenol solution, calibration (1 μL = 500 ng Cl⁻), C₆H₃Cl₃O: Dilute 5 mL of the trichlorophenol stock solution to 100 mL with methanol.

5.12 Trichlorophenol standard, instrument calibration: First, nitrate-wash a single column packed with 40 mg of activated carbon, as instructed for sample analysis, and then inject the column with 10 μL of the calibration solution.

5.13 Trichlorophenol standard, adsorption efficiency (100 μg Cl⁻/liter): Prepare an adsorption-efficiency standard by injecting 10 μL of stock solution into 1 liter of reagent water.

5.14 Blank standard: The methanol used to prepare the calibration standard should be used as the blank standard.

6.0 SAMPLE COLLECTION, PRESERVATION, AND HANDLING

6.1 All samples must be collected using a sampling plan that addresses the considerations discussed in Chapter Nine.

6.2 All samples should be collected in bottles with Teflon septa (e.g., Pierce #12722 or equivalent) and be protected from light. If this is not possible, use amber glass 250-mL bottles fitted with Teflon-lined caps. Foil may be substituted for Teflon if the sample is not corrosive. Samples must be preserved by acidification to pH <2 with sulfuric acid, stored at 4°C, and protected against loss of volatiles by eliminating headspace in the container. Samples should be analyzed within 28 days. The container must be washed and muffled at 400°C before use, to minimize contamination.

6.3 All glassware must be dried prior to use according to the method discussed in Step 3.1.1.

7.0 PROCEDURE

7.1 Sample preparation:

7.1.1 Special care should be taken in handling the sample in order to minimize the loss of volatile organohalides. The adsorption procedure should be performed simultaneously on duplicates.

7.1.2 Reduce residual chlorine by adding sulfite (5 mg sodium sulfite crystals per liter of sample). Sulfite should be added at the time of sampling if the analysis is meant to determine the TOX concentration at the time of sampling. It should be recognized that TOX may increase on storage of the sample. Samples should be stored at 4°C without headspace.

7.2 Calibration:

7.2.1 Check the adsorption efficiency of each newly prepared batch of carbon by analyzing 100 mL of the adsorption efficiency standard, in duplicate, along with duplicates of the blank standard. The net recovery should be within 5% of the standard value.

7.2.2 Nitrate-wash blanks (method blanks): Establish the repeatability of the method background each day by first analyzing several nitrate-wash blanks. Monitor this background by spacing nitrate-wash blanks between each group of eight pyrolysis determinations. The nitrate-wash blank values are obtained on single columns packed with 40 mg of activated carbon. Wash with the nitrate solution, as instructed for sample analysis, and then pyrolyze the carbon.

7.2.3 Pyrolyze duplicate instrument-calibration standards and the blank standard each day before beginning sample analysis. The net response to the calibration standard should be within 3% of the calibration-standard value. Repeat analysis of the instrument-calibration standard after each group of eight pyrolysis determinations and before resuming sample analysis, and after cleaning or reconditioning the titration cell or pyrolysis system.

7.3 Adsorption procedure:

7.3.1 Connect two columns in series, each containing 40 mg of 100/200-mesh activated carbon.

7.3.2 Fill the sample reservoir and pass a metered amount of sample through the activated-carbon columns at a rate of approximately 3 mL/min.

NOTE: 100 mL of sample is the preferred volume for concentrations of TOX between 5 and 500 $\mu\text{g/L}$, 50 mL for 501 to 1000 $\mu\text{g/L}$, and 25 mL for 1001 to 2000 $\mu\text{g/L}$. If the anticipated TOX is greater than 2000 $\mu\text{g/L}$, dilute the sample so that 100 mL will contain between 1 and 50 μg TOX.

7.3.3 Wash the columns-in-series with 2 mL of the 5,000-mg/L nitrate solution at a rate of approximately 2 mL/min to displace inorganic chloride ions.

7.4 Pyrolysis procedure:

7.4.1 The contents of each column are pyrolyzed separately. After being rinsed with the nitrate solution, the columns should be

protected from the atmosphere and other sources of contamination until ready for further analysis.

7.4.2 Pyrolysis of the sample is accomplished in two stages. The volatile components are pyrolyzed in a CO₂-rich atmosphere at a low temperature to ensure the conversion of brominated trihalomethanes to a titratable species. The less volatile components are then pyrolyzed at a high temperature in an O₂-rich atmosphere.

7.4.3 Transfer the contents of each column to the quartz boat for individual analysis.

7.4.4 Adjust gas flow according to manufacturer's directions.

7.4.5 Position the sample for 2 min in the 200°C zone of the pyrolysis tube.

7.4.6 After 2 min, advance the boat into the 800°C zone (center) of the pyrolysis furnace. This second and final stage of pyrolysis may require from 6 to 10 min to complete.

7.5 Detection: The effluent gases are directly analyzed in the micro-coulometric-titration cell. Carefully follow manual instructions for optimizing cell performance.

7.6 Breakthrough: The unpredictable nature of the background bias makes it especially difficult to recognize the extent of breakthrough of organohalides from one column to another. All second-column measurements for a properly operating system should not exceed 10% of the two-column total measurement. If the 10% figure is exceeded, one of three events could have happened: (1) the first column was overloaded and a legitimate measure of breakthrough was obtained, in which case taking a smaller sample may be necessary; (2) channeling or some other failure occurred, in which case the sample may need to be rerun; or (3) a high random bias occurred, and the result should be rejected and the sample rerun. Because it may not be possible to determine which event occurred, a sample analysis should be repeated often enough to gain confidence in results. As a general rule, any analysis that is rejected should be repeated whenever a sample is available. In the event that repeated analyses show that the second column consistently exceeds the 10% figure and the total is too low for the first column to be saturated and the inorganic Cl is less than 20,000 times the organic chlorine value, then the result should be reported, but the data user should be informed of the problem. If the second-column measurement is equal to or less than the nitrate-wash blank value, the second-column value should be disregarded.

7.7 Calculations: TOX as Cl⁻ is calculated using the following formula:

$$\frac{(C_1 - C_3) + (C_2 - C_3)}{V} = \mu\text{g/L Total Organic Halide}$$

where:

C_1 = $\mu\text{g Cl}^-$ on the first column in series;

C_2 = $\mu\text{g Cl}^-$ on the second column in series;

C_3 = predetermined, daily, average, method-blank value
(nitrate-wash blank for a 40-mg carbon column); and

V = the sample volume in liters.

8.0 QUALITY CONTROL

8.1 All quality control data should be maintained and available for easy reference or inspection.

8.2 Employ a minimum of one blank per sample batch to determine if contamination or any memory effects are occurring.

8.3 Verify calibration with an independently prepared check standard every 15 samples.

8.4 Run one spike duplicate sample for every 10 samples. A duplicate sample is a sample brought through the whole sample-preparation and analytical process.

9.0 METHOD PERFORMANCE

9.1 Under conditions of duplicate analysis, the method detection limit is 5 $\mu\text{g/L}$.

9.2 Analyses of distilled water, uncontaminated ground water, and ground water from RCRA waste management facilities spiked with volatile chlorinated organics generally gave recoveries between 75-100% over the concentration range 10-500 $\mu\text{g/L}$. Relative standard deviations were generally 20% at concentrations greater than 25 $\mu\text{g/L}$. These data are shown in Tables 1 and 2.

10.0 REFERENCES

1. Gaskill, A., Compilation and Evaluation of RCRA Method Performance Data, Work Assignment No. 2, EPA Contract No. 68-01-7075, September 1986.
2. Stevens, A.A., R.C. Dressman, R.K. Sorrell, and H.J. Brass, Organic Halogen Measurements: Current Uses and Future Prospects, Journal of the American Water Works Association, pp. 146-154, April 1985.
3. Tate, C., B. Chow, et al., EPA Method Study 32, Method 450.1, Total Organic Halides (TOX), EPA/600/S4-85/080, NTIS: PB 86 136538/AS.

TABLE 1. METHOD PERFORMANCE DATA^a

Spiked Compound	Matrix ^b	TOX Concentration (μg/L)	Percent Recovery
Bromobenzene	D.W.	443	95
Bromodichloromethane	D.W.	160	98
Bromoform	D.W.	160	110
Bromoform	D.W.	238	100
Bromoform	G.W.	10	140
Bromoform	G.W.	31	93
Bromoform	G.W.	100	120
Chloroform	D.W.	98	89
Chloroform	D.W.	112	94
Chloroform	G.W.	10	79
Chloroform	G.W.	30	76
Chloroform	G.W.	100	81
Dibromodichloromethane	D.W.	155	86
Dibromodichloromethane	D.W.	374	73
Tetrachloroethylene	G.W.	10	79
Tetrachloroethylene	G.W.	30	75
Tetrachloroethylene	G.W.	101	78
trans-Dichloroethylene	G.W.	10	84
trans-Dichloroethylene	G.W.	30	63
trans-Dichloroethylene	G.W.	98	60

^aResults from Reference 2.

^bG.W. = Ground Water.

D.W. = Distilled Water.

TABLE 2. METHOD PERFORMANCE DATA^a

Sample Matrix	Unspiked TOX ($\mu\text{g/L}$)	Spike Level	Percent Recovery
Ground Water	68, 69	100	98, 99
Ground Water	5, 12	100	110, 110
Ground Water	5, 10	100	95, 105
Ground Water	54, 37	100	111, 106
Ground Water	17, 15	100	98, 89
Ground Water	11, 21	100	97, 89

^aResults from Reference 3.

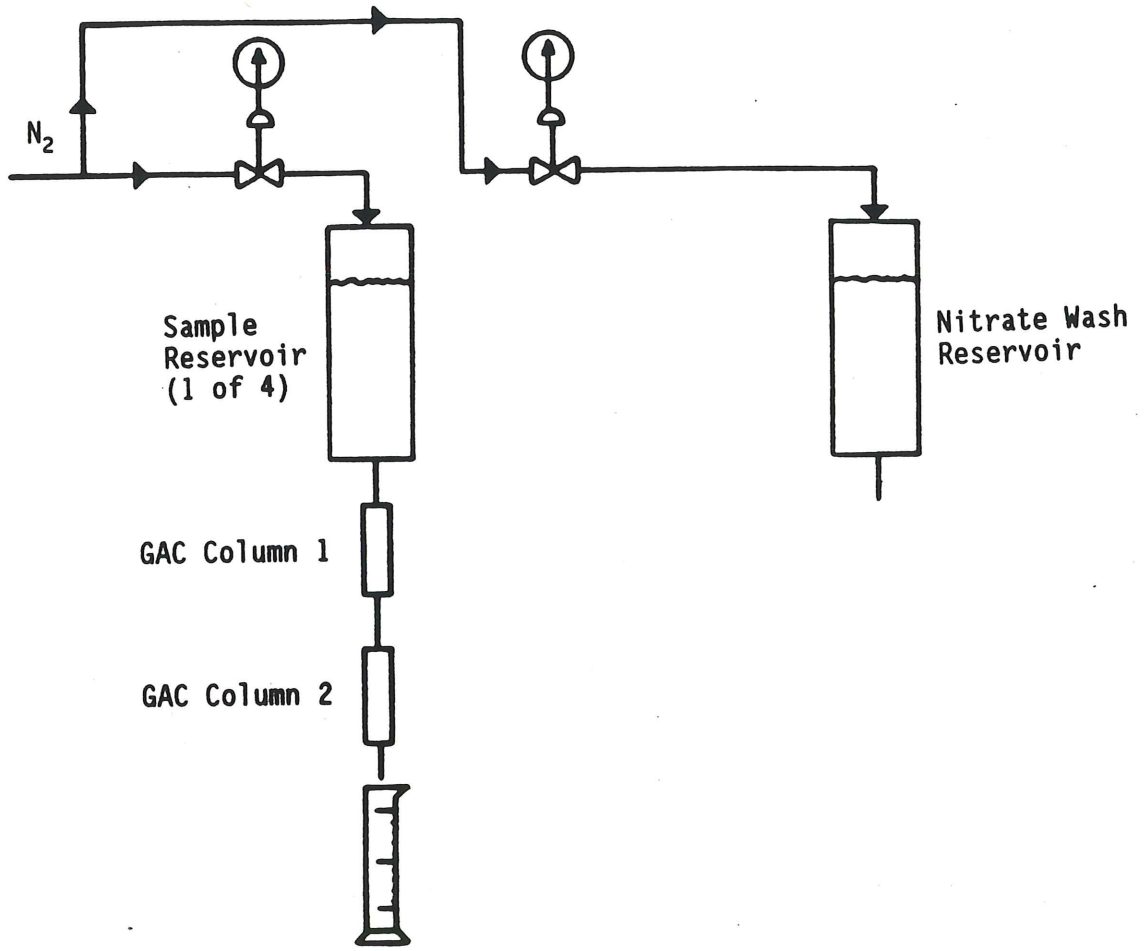

Figure 1. Schematic Diagram of Adsorption System

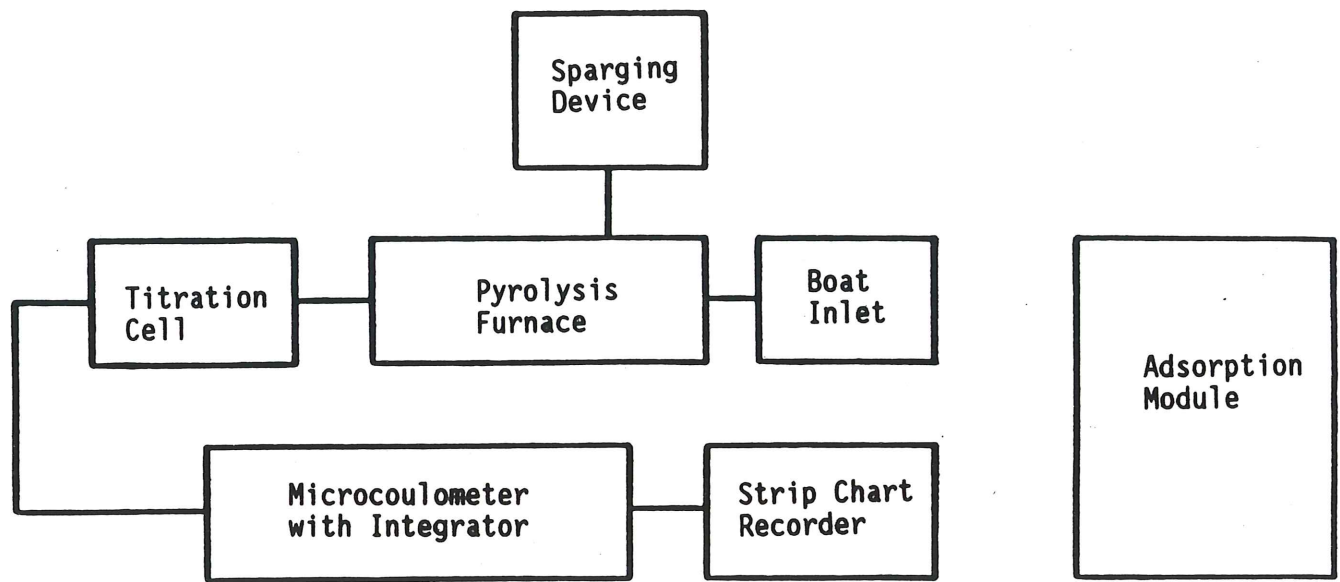
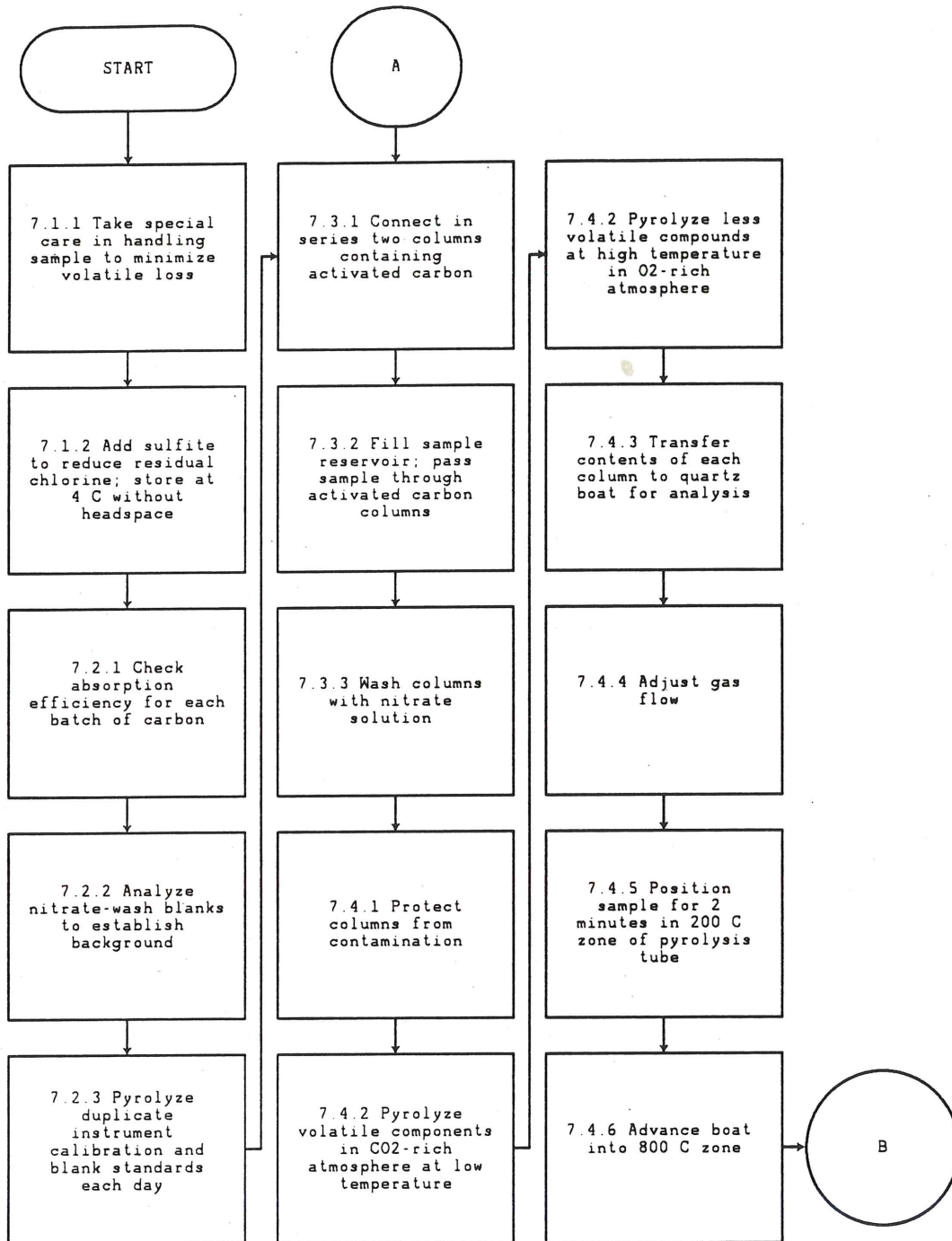

Figure 2. Flowchart of Analytical System

METHOD 9020A
TOTAL ORGANIC HALIDES (TOX)



METHOD 9020A
(Continued)

