

US EPA ARCHIVE DOCUMENT



UNITED STATES ENVIRONMENTAL PROTECTION AGENCY
REGION 5
77 WEST JACKSON BOULEVARD
CHICAGO, IL 60604-3590

MAY 29 2003

REPLY TO THE ATTENTION OF:

D-8J

Mike Ebert, Plant Manager
Safety Kleen Oil Recovery Company
601 Riley Road
East Chicago, Indiana 46312-1638

Re: Modification Approval to Store and Dispose PCB-contaminated Waste Oil
by Re-refining Process - Safety-Kleen Oil Recovery Co., East Chicago, Indiana

Dear Mr. Ebert:

The United States Environmental Protection Agency (U.S. EPA) has received your request dated February 28, 2003, for modifications to the Approval to store and process PCB-contaminated waste oil issued to Safety-Kleen Oil Recovery Company (SKORC) on October 2, 1998 (Approval). The U.S. EPA has also received your letter of March 24, 2003, withdrawing some modifications related to the storage and processing of PCB oils in volumes that exceed the maximum allowed in the Approval. In addition, the U.S. EPA has received, on April 1, 2003, your notice of intent to continue the operations of SKORC's re-refining system under the conditions of the Approval, which will expire in October 2003. The notice of intent is in compliance with Condition 84 of the Approval.

The U.S. EPA has determined that the requested modifications will not affect the efficiency and overall performance of SKORC's re-refining process to destroy PCBs. The U.S. EPA has also determined that SKORC's re-refining process, when operated in accordance with the conditions of the October 2, 1998 Approval and the modifications as described below, will not present an unreasonable risk of injury to human health or the environment. As a result of these determinations, we approve the following modifications to the Approval:

- Condition 29 of the Approval is modified based on the current calibration of the Honeywell PSIA transmitter (PI-305). The operating pressure for the Heavy Vacuum Oil Evaporator shall be maintained at 6-9 mm Hg.
- The light vacuum oil and the medium vacuum oil from the vacuum distillation process shall be stored in one tank prior to being fed to the hydrotreater and shall be sampled in accordance with the Sampling Procedure and Frequency (Attachment II). Condition 33 and the Vacuum Distillation Process Flow Diagram (Attachment I) of the Approval are updated to show this modification.

- The clean oil from the hydrotreating process shall now leave the Steam Stripper V-404 and enter the Fractionating Tower V-416. The Hydrotreater Process Flow Diagram (Attachment I) of the Approval is modified to show the removal of the Side Stripper V-413 and the installation of a new Fractionating Tower.
- Sampling Procedure and Frequency (Attachment II) has been modified to reflect the above changes.
- The revisions to Safety-Kleen Method # 9202 (Rev. 12/99) and Safety-Kleen Method # 9203 (Rev. 09/02) are approved and the Sampling Methodology (Attachment IV) of the Approval is modified to show the new revision.

During the processing of the PCB waste oil, SKORC must follow all other conditions in the original Approval dated October 2, 1998. The approved modifications may be withdrawn or further conditions may be added at any time if the U.S. EPA determines that the operation of the process presents an unreasonable risk of injury to human health or the environment. Moreover, violation of any conditions included as part of the approved modifications may subject SKORC to enforcement action and/or termination of the approved modifications.

It is the responsibility of SKORC to ensure that all applicable provisions of the Toxic Substances Control Act and the Federal PCB regulations are followed. Violation of any of the applicable provisions may be cause for rescission of the Approval, or the modifications. Furthermore, this approval does not relieve SKORC of its responsibility to comply with all other Federal, State and local regulations and ordinances for transportation, siting, operation and maintenance of its facility.

The U.S. EPA reserves the right for its authorized representatives to observe SKORC's disposal activities and inspect records which the company is required to maintain under the Federal PCB regulations and the Approval during normal operations and at other reasonable times.

Please contact Priscilla Fonseca, of my staff, at (312) 886-1334, if you have any questions pertaining to this matter.

Sincerely,



Phyllis A. Reed, Acting Director
Waste Pesticides and Toxics Division

Enclosures

cc: Lori Kaplan, IDEM
George Ritchotte, IDEM

ATTACHMENT 1

Dehydration
Process Flow Diagram

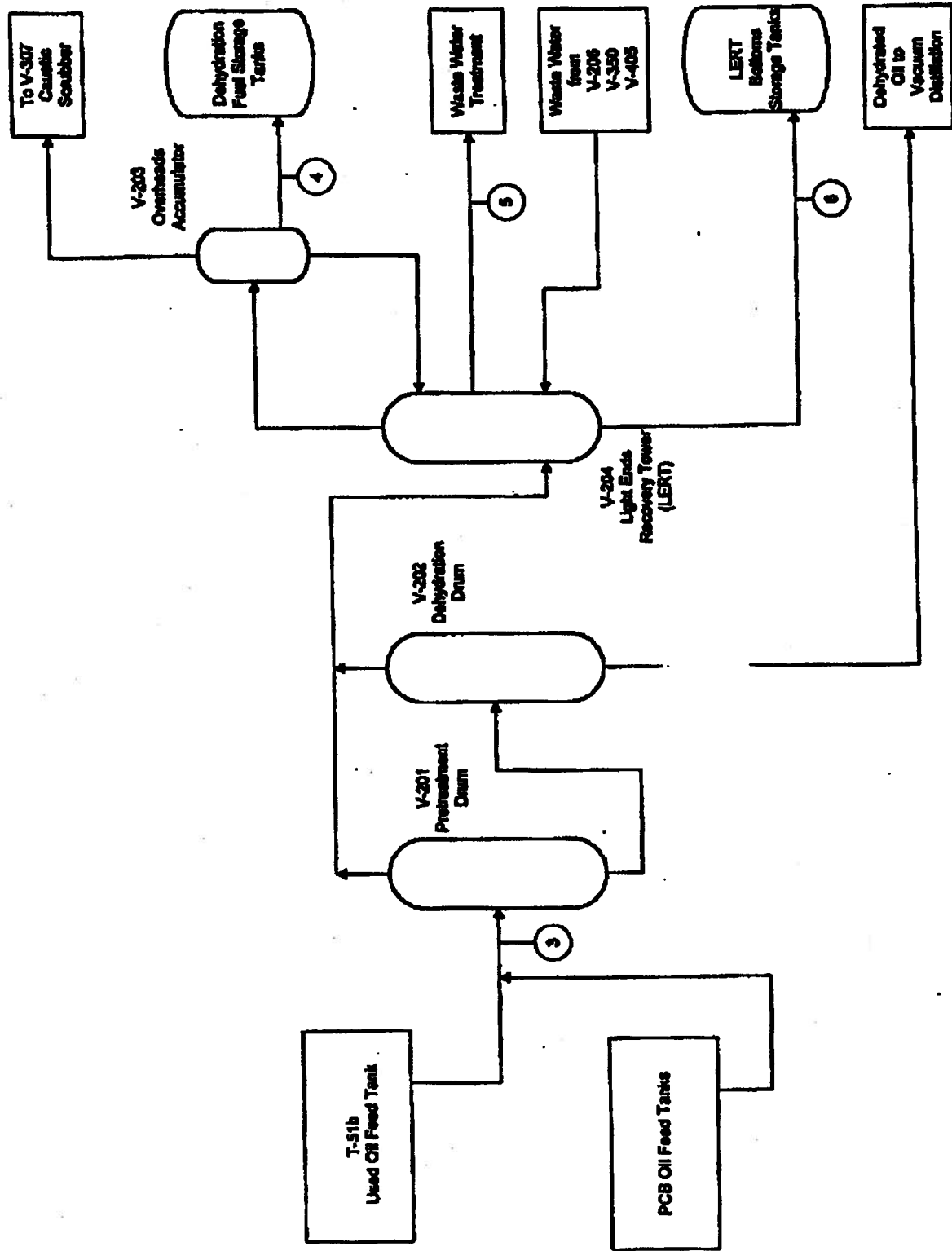

ATTACHMENT I

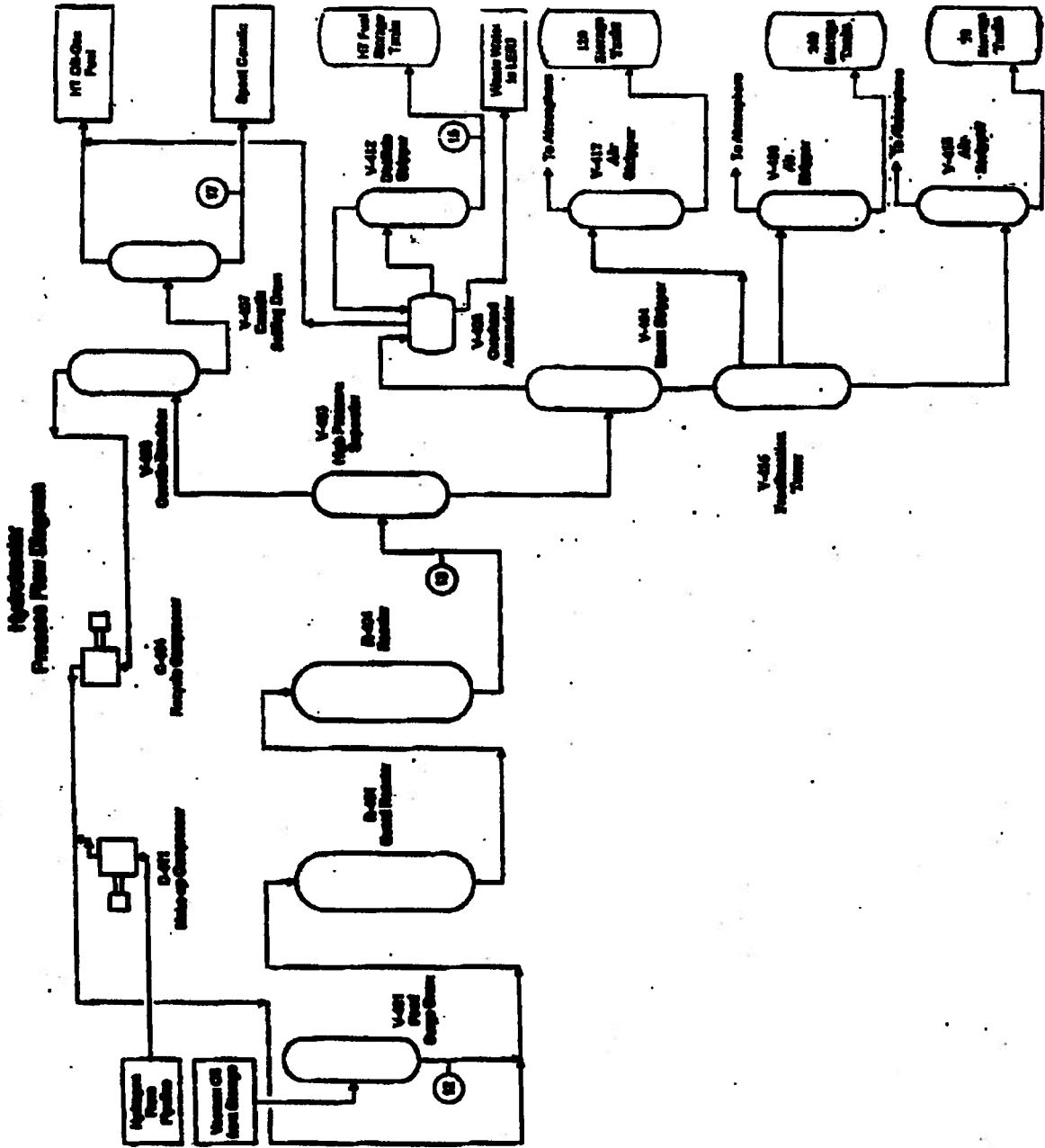

ATTACHMENT II

The sampling procedure and frequency described below shall be implemented for every 376,600 gallons of feed into the distillation process.

Sample # and I.D.	Sampling Frequency	Sampling Method	Acceptable Limits
1. Waste Receipt	each shipment	coliwasa	
2. Receiving Guard Tank	each guard tank	grab sample	
3. Feed to Pre-treatment tank V-201	Every six (6) hours during processing of PCB contaminated waste oil	grab sample	200 ppm PCBs (Feed ratio will be calculated and a target concentration for the maximum limit will be on display at the control room)
4. Dehydration Overhead Receiver (V-203)	every six (6) hours while processing PCB contaminated waste oil	grab sample to be composited into one sample	< 2 ppm PCBs
5. LERT (V-208)* Dehydration Water	East Chicago Sanitary District Pretreatment Discharge Permit sampling requirement	grab sample	East Chicago Sanitary District Pretreatment Discharge Permit Standard **
6. LERT (V-204) Bottoms (ethylene glycol)	every six (6) hours while processing PCB contaminated waste oil	grab sample	< 2 ppm PCBs
7. VFS Overhead (V-206) Fuel	every six (6) hours while processing PCB contaminated waste oil	grab sample	< 2 ppm PCBs
8. Lite Vacuum Oil (V-330) Rundown	one grab at the mid-point of the processing of PCB contaminated waste oil	grab sample for process control	NA
9. Medium Vacuum Oil Rundown (V-304)	one grab at the mid-point of the processing of PCB contaminated waste oil	grab sample for process control	NA
10. Heavy Vacuum Oil Rundown (V-305)	one grab at the mid-point of the processing of PCB contaminated waste oil	grab sample	NA
11. LUWA Bottoms Asphalt Extender	Every two (2) hours while processing PCB contaminated waste oil	grab sample	< 2 ppm PCBs

Sample # and I.D.	Sampling Frequency	Sampling Method	Acceptable Limits
12. Feed to hydrotreater	one grab at the beginning of the hydrotreating process	grab sample	NA
13. R403 Outlet	three times during the hydrotreating process	grab sample	<2ppm ***
14. Hydrotreater product	one grab at the end of the hydrotreating process for each type of lubricating oil	grab sample	< 2 ppm PCBs
15. (V-405) Rundown (kerosene)	three times during processing	grab sample to be composited into one sample	< 2 ppm PCBs
16. V-307 Caustic solution	three times during processing	grab sample to be composited into one sample	< 2 ppm PCBs
17. Spent Caustic V-407	three times during processing	grab sample to be composited into one sample	< 2 ppm PCBs
18. V-417 Air Stripper (Spindle oil)	three times during processing	grab sample to be composited into one sample	< 2 ppm PCBs
19. City Effluent	East Chicago Sanitary District Discharge Permit Requirement	grab / composite	East Chicago Sanitary District Discharge Permit standard

* Wastewater will be held for testing at the emulsion tank and the oil phase will be returned for processing in the distillation system.

** The PCB concentration of the wastewater shall not exceed the limit set by East Chicago Sanitary District Pre-treatment Approval

*** SKORC shall take action if the sample result is ≥ 2 ppm PCBs such as reducing the feed rate or changing the catalyst.

ATTACHMENT IV

SKORC and/or its contract laboratory must determine the PCB concentration of the feed and all the streams generated during the re-refining of PCB contaminated waste oil and rinsates, as identified in Attachment I and II, by following the methodologies listed below.

I. Waste Oil, Distillation Products and By-Products

- a. To determine the PCB level in waste oil, distillation products and by-products, SKORC must use Safety-Kleen Method # 9202 (Rev. 12/99). Method # 9202 (Rev. 12/99) is an update to Safety-Kleen Method # 9202 (Rev.3/94)) that was approved by the U.S.EPA and was utilized during the PCB demonstration of SKORC's re-refining process. Method # 9202 (Rev.12/99) is SKORC's Standard Operating Procedure for PCBs in waste oil based on, and consistent with guidance from SW 846 (Update III) Methods 3580A, 3620B, 3660B, 3665A, and 8082.

Future revisions to Safety-Kleen Method # 9202 (Rev.12/99) must be reviewed by U.S. EPA to determine if these changes are significant.

- b. The analytical results must be reported as total PCBs (on an oil weight basis), calculated by comparison to Aroclor standards identified by SW-846 (Update III) Method 8082, including Aroclor 1262 and Aroclor 1268. Specific Aroclors used for calculation of total PCBs shall be reported.

II. Wastewater

- a. SKORC must use the test procedure described as "Modified Method 504 with Safety-Kleen Method # 9202 (Rev. 12/99)" for PCB analysis of V-208 and City effluent wastewaters. This test procedure was approved by the U.S. EPA and East Chicago Sanitary District in May 1999.
- b. Sample extraction method must be consistent with the technique used in the Method of Detection Limit (MDL) study.
- c. SKORC's wastewater is a complex matrix and needs specific cleanup methods in order to improve the detection limit.

Florisil and acid treatment must be performed on the wastewater samples. In addition, sulfur cleanup with mercury or copper must be utilized as necessary.

- d. The lowest achievable detection limit must be obtained. After the above cleanup procedures are employed, a minimal dilution of the extract must be used to produce a usable chromatogram.

- e. A multi-point calibration curve must be used. The response for the clean & diluted extracts must be within the calibration curve for quantitation.
- f. The analytical results must be reported as total PCBs calculated by comparison to Aroclor standards identified by SW-846 (Update III) Methods 8082, including Aroclors 1262 and 1268. Specific Aroclors used for calculation of total PCBs are also to be reported.

III. Hydrotreater Products:

- a. SKORC must use the U.S. EPA approved Safety-Kleen Method # 9213 (Rev. 9/02), Safety-Kleen's Standard Operating Procedure for Analysis of PCB Congeners. This method of analysis was utilized during the demonstration of SKORC's re-refining process.
- b. Instrument calibration must be performed by utilizing a specially prepared calibration standard composed of selected congeners (from monochlorobiphenyl to decachlorobiphenyl) as identified in the Safety-Kleen Method # 9213 (Rev.9/02).
- c. Every observable peak is calculated by comparison to an external standard, one PCB congener per homolog peak having the nearest retention time to each appropriate PCB peak to be quantified. A final PCB total value is calculated by adding the ten homolog groups.

