

US EPA ARCHIVE DOCUMENT

U.S. DEPARTMENT OF ENERGY  
CARLSBAD FIELD OFFICE

A CONCEPTUAL PLAN FOR  
**SALT DEFENSE DISPOSAL  
INVESTIGATIONS**  
FOR THE DISPOSAL OF DOE-EM MANAGED WASTES



JUNE 2012

DOE/CBFO-12-3485  
REVISION 0

INTENTIONALLY LEFT BLANK

## EXECUTIVE SUMMARY

# SALT DEFENSE DISPOSAL INVESTIGATIONS FOR DOE-EM WASTES

---

Disposal of nuclear waste in salt remains a viable, yet underutilized concept in the United States. The well-recognized success of the Waste Isolation Pilot Plant (WIPP) mission for the disposal and isolation of defense transuranic (TRU) waste provides strong positive testimony in support of salt disposal for a variety of nuclear wastes. Salt formations in the United States hold great promise toward solving major disposal issues for thermally and radioactively hot waste currently managed by the United States Department of Energy Office of Environmental Management (DOE-EM).

Previous salt repository studies and operations have been adequate to demonstrate safe disposal of TRU waste in salt. Scientific work performed both in the U.S. and abroad, strongly supports the judgment that it would be safe to dispose of thermally hotter waste in salt. However, for thermally hot wastes and for emplacement concepts designed for these types of wastes (either alcove emplacement or in-drift emplacement), this previously performed work needs to be verified through confirmatory testing, augmented to address specific uncertainties, and enhanced to include specific disposal concepts, which are addressed in this conceptual plan. The versatile disposal concepts could gain acceptance by way of demonstration.

Motivating this research program is the underlying hypothesis that salt may be an advantageous medium for the permanent disposal of heat-generating waste. There is strong empirical evidence that the introduction of higher heat loads than that exhibited by TRU waste would enhance repository performance because thermal activation of the creep processes promotes plastic flow of the intact salt, leading to more rapid encapsulation. Higher temperatures are also expected to intensify moisture removal from the disposal system during emplacement operations and pre-closure. It will be important to achieve a firm understanding of the prevailing hydrologic and chemical effects during a demonstration of an emplacement concept to provide a basis for a decision regarding disposal of defense wastes. Demonstration of the drift disposal concept for defense high-level waste (DHLW) would provide confidence to stakeholders, regulators, and policy makers that salt is a fully efficient medium for these heat-generating wastes. Laboratory testing and modeling alone has not, and will never be, solely adequate to prove performance of and license a nuclear waste repository. A field demonstration test is an essential component of such a program, as described within this Salt Defense Disposal Investigation (SDDI) conceptual plan.

In June 2011, a management proposal, DOE/CBFO-11-3470, Salt Disposal Investigations (DOE 2011b), was completed that provided a science-based scope of work for a defined research program (laboratory work and modeling efforts) intended to establish the foundation for a proof-of-principle field test for disposal of heat-generating nuclear waste. The proposal was based upon an alcove emplacement strategy with a geometry that allowed for straightforward distribution of hot waste packages (~8.5 kilowatts each) to spread out the heat load (~40 watts per square meter). The research program proposed would directly test a disposal arrangement that balances heat loading with waste and repository temperature limits. The Salt Disposal Investigations (SDI) proposed study would fill information gaps in current knowledge of the thermomechanical, hydrological, and chemical behavior of salt and wastes disposed in salt and form the technical foundation for design, operation, coupled process modeling, and performance assessment of future salt repositories for heat-generating nuclear waste.

Subsequent discussions and analyses have led to the conclusion that there is merit in an approach that covers a range of thermal loads that, in total, covers the entire spectrum of heat-emitting wastes in need of disposal, rather than focusing only on the very high heat loads. For example, if policy drives the nation toward disposal of cooler DHLW as a priority over higher heat-generating wastes, then the original SDI testing program mentioned above could be managed in a manner that prioritizes an in-drift disposal concept for intermediate heat wastes. In addition, some of the commercial used nuclear fuel (UNF) inventory falls in the intermediate thermal range, and even more of the commercial inventory would be included in a strategy of disposal of a smaller number of assemblies per disposal package than was envisioned for the Yucca Mountain repository. Thus, the current conceptual plan describes a field demonstration program, herein referred to as Salt Defense Disposal Investigations (SDDI) in deference to its applicability to the disposal of DOE-EM managed wastes, that covers an intermediate heat range relevant to DHLW, most of the defense spent nuclear fuel (SNF) inventory, and some of the commercial UNF inventory. Both of these test programs, the SDI and the SDDI, as well as other judiciously selected salt-testing activities can be conducted within the WIPP Underground Research Laboratory (URL), currently under construction.

This SDDI conceptual plan provides a science-based scope of work (with time and cost estimates) for a defined research program (laboratory work and modeling efforts) intended to establish the foundation for a proof-of-principle field test for disposal of heat-generating nuclear waste. This conceptual plan is considered a preliminary and internal scoping plan meant to reach a decision-in-principle within DOE Headquarters. Test-specific requirements such as parameter identification, data quality objectives, instrumentation, calibration requirements, precise borehole and gage placement, sample control, test procedures, data collection processes, and other test- or modeling-specific information will be provided in an ensuing field test plan to be developed. Practical experience, pre-test modeling efforts, and laboratory testing will help inform the test planning as to expected test conditions. Detailed cost estimates and schedules will be developed and refined as the program matures.

The disposal concept being proposed is expected to demonstrate operational efficiency and the ability to handle various sizes and shapes of DHLW. The expectations for in situ behavior can be well approximated from extensive WIPP experience and knowledge of salt deformation. The demonstration of placing run-of-mine salt over the waste, which in actual disposal operations would create a radiological barrier, is important for operational evaluation and performance objectives. The heat from the buried canisters will warm the salt mass and accessible moisture would be expected to transport with the airflow, and perhaps out of the repository. Measurement of the drying effect is one of test goals, as describe in this conceptual plan.

The field investigations involved with the SDDI conceptual plan and SDI proposal represent two possible activities that might be considered for installation in the new URL being developed at the WIPP site. The underground studies involved with these two documents would necessitate integration with other constructive uses of the URL. While both programs could be conducted simultaneously, it is more prudent to conduct them in a phased manner (separated by approximately a year or so) given the availability of resources, physical space in the underground, and other test implementation constraints. In addition, a phased approach allows a learning opportunity in terms of specialized instrument selection, demonstration, and emplacement. If the test programs could be overlapped and phased in a manner that prevents large gaps in underground testing and other scientific activities, significant efficiencies (both cost and schedule) could be realized in both programs by sharing of resources, facility infrastructure, and equipment.

**TABLE OF CONTENTS**

**EXECUTIVE SUMMARY .....iii**

**1 PROJECT INTRODUCTION..... 1**

**2 IN-DRIFT EMPLACEMENT CONCEPT ..... 15**

**2.1 IN-DRIFT EMPLACEMENT VERSUS ALCOVE OR BOREHOLE EMPLACEMENT ..... 15**

**2.2 THE IN-DRIFT EMPLACEMENT CONCEPT ..... 16**

**3 PROPOSED SDDI RESEARCH PROGRAM ..... 19**

**3.1 FUNCTIONAL AND OPERATIONAL REQUIREMENTS AND TEST PLANNING ..... 19**

**3.2 LABORATORY THERMAL, MECHANICAL, HYDROLOGIC, AND CHEMICAL STUDIES ..... 19**

**3.3 PREDICTIVE AND COUPLED PROCESS MODELING ..... 20**

        3.3.1. Pre-Test Predictive Modeling ..... 20

        3.3.2. Thermomechanical and Hydrologic Benchmark Modeling ..... 24

**3.4 FIELD TEST PROOF OF PRINCIPLE ..... 25**

        3.4.1. Conceptual Field Test Design..... 26

        3.4.2. SDDI Test Parameters..... 32

        3.4.3. Mining and Construction Support ..... 34

        3.4.4. Instrumentation for the Field Test ..... 35

        3.4.5. Pre-Test Shakedown of Instrumentation ..... 42

**4 PRELIMINARY COST AND SCHEDULE..... 45**

**5 REFERENCES..... 48**

**APPENDIX A: KEY CONTRIBUTORS TO THE SDDI PLAN .....A-1**

**APPENDIX B: EXAMPLES OF DOE SNF AND HLW CANISTERS .....B-1**

## LISTS OF TABLES AND FIGURES

### LIST OF TABLES

TABLE 1-1 Heat Loads for DOE-Managed Waste Inventories (Carter 2012) .....	5
TABLE 3-1 Temperatures Predicted for the Preliminary Modeling Cases .....	22
TABLE 3-2 Partitioning of Responsibilities - Construction & Ops Support and Testing .....	34
TABLE 4-1 Estimated Costs for the SDDI Field Test .....	46

**LIST OF FIGURES AND PHOTOS**

FIGURE 1-1 Relationship of the SDDI Conceptual Plan to Other SDI/SDDI Documents ..... 3

FIGURE 1-2 DOE-EM Projected HLW Inventory ..... 5

FIGURE 1-3 Stable Geologic Salt Formations within the 48 Contiguous States ..... 9

FIGURE 2-1 In-Drift Waste Emplacement Concept ..... 17

FIGURE 2-2 Typical Load Haul Dump Configured to Sling Run-of-Mine Salt ..... 17

FIGURE 2-3 Disposal Room Emplacement and Closure ..... 18

FIGURE 3-1 FEHM Grid for Conduction Only Calculation ..... 21

FIGURE 3-2 Predicted Temperatures for a Vertical Cross Section Along the Drift (3-2a, b, c) ..... 23

FIGURE 3-3 Perspective View of the Mining Layout for the SDDI Thermal Test ..... 27

FIGURE 3-4 Areal View of a SDDI Test Drift #2 ..... 28

FIGURE 3-5 Area within the WIPP URL for the SDDI Thermal Test ..... 30

FIGURE 3-6 Plan View of the Mining Layout for the SDDI Thermal Test ..... 31

FIGURE 3-7 Profile View of SDDI Test Drift #2 ..... 31

FIGURE 3-8 Profile View of SDDI Test Drift #1 with Basic Test Characteristics ..... 33

FIGURE 3-9 Profile View of SDDI Test Drift #2 with Basic Test Characteristics ..... 33

FIGURE 4-1 Estimated Schedule for the SDDI Field Test ..... 47

FIGURE B-1 Empty HLW Canister at the SRS .....B-1

FIGURE B-2 Empty HLW Canister at Hanford .....B-2

PHOTO 3-1 Salt Backfill ..... 28

PHOTO 3-2 MPBX Installation ..... 37

PHOTO 3-3 GPR Measurements ..... 40



INTENTIONALLY LEFT BLANK

# 1. PROJECT INTRODUCTION

---

## Overview and Introduction

In June 2011, DOE/CBFO-11-3470, Salt Disposal Investigations (DOE 2011b), was completed that provided a science-based scope of work for a defined scope of research (laboratory work and modeling efforts) intended to establish the foundation for a proof-of-principle field test for disposal of heat-generating nuclear waste. The SDI proposal was based upon an alcove emplacement strategy with a geometry that allowed for a straightforward way to distribute hot waste packages (~8.5 kilowatts each) to distribute the heat load (~40 watts per square meter). The research program proposed would directly test a disposal arrangement that balances heat loading with waste and repository temperature profiles. It would fill information gaps in current knowledge of the thermomechanical, hydrological, and chemical behavior of salt and wastes disposed in salt and form the technical foundation for design, operation, coupled process modeling, and performance assessment of future salt repositories for heat-generating nuclear waste. Since the issuing of this original SDI proposal, the Blue Ribbon Commission on America's Nuclear Future (BRC), chartered to recommend a new strategy for managing the back end of the fuel cycle, has issued its report (BRC 2012), calling for, among other actions, "prompt efforts to develop one or more geologic disposal facilities."

While the rationale for the SDI project applies to both civilian and defense wastes, it has become clear in discussions with United States Department of Energy Office of Environmental Management (DOE-EM) that the SDI proposal does not specifically address information needed for EM to make important early decisions on disposal of the defense high-level waste (DHLW) and Spent Nuclear Fuel (SNF) that it manages. Subsequent discussions and analyses have led to the conclusion that there is merit in an approach that covers a range of thermal loads that, in total, covers the entire spectrum of heat-emitting wastes in need of disposal, rather than focusing only on the very high heat loads. To address the needs explicitly associated with disposal of these DOE-EM managed wastes, this conceptual plan provides an overview of a drift emplacement strategy and corresponding test program based on disposal canisters laid on the drift floor and covered with crushed salt (run-of-mine) backfill for shielding. This emplacement concept will be referred to as "in-drift emplacement" to distinguish it from the "alcove emplacement" scenario described in the June 2011 SDI management proposal for high-heat-generating wastes, or in-drift horizontal "borehole emplacement," which is currently used for remote-handled waste at the WIPP.

A corresponding testing program [henceforth referred to as Salt Defense Disposal Investigations (SDDI)] is described herein to demonstrate confirmation of certain principles in salt and to demonstrate an in-drift disposal concept, providing confidence in and confirmation of the concept. If policy drives the nation toward disposal of cooler DHLW as a priority over higher heat-generating wastes, the original SDI testing program mentioned above could be phased in such a manner that allows for the early opportunity for data retrieval and for a demonstration of an in-drift disposal concept for intermediate-heat wastes through the SDDI testing program. In addition, some of the commercial UNF inventory is represented in the intermediate thermal range, and even more of the commercial inventory would be included in a disposal strategy based on a smaller number of assemblies per disposal package than was envisioned for the Yucca Mountain repository. Thus, this SDDI conceptual plan describes a demonstration testing program, specific to the disposal of DOE-EM managed wastes, which covers an intermediate heat range relevant to DHLW, most of the defense SNF inventory, and some of the commercial UNF inventory.

Both of these test programs, the SDI and the SDDI, as well as other large-scale and small-scale salt testing activities (e.g., mining research and seal demonstrations) can be conducted within the WIPP URL, which is currently under construction. Although many of the test configurations of early thermal experiments, many conducted at WIPP, were premised on waste emplacement in vertical boreholes, existing data from these experiments will be comprehensively evaluated to extract the maximum possible return on investment.

When the DHLW thermal test program was terminated at WIPP in 1987, the country lost an opportunity to fully understand important processes (e.g., water migration under thermal loads). Therefore, a key focus of this proposed phase of salt testing is to develop and deploy instruments that track water and water vapor movement more rigorously than has been done in the past. These disposal demonstrations will be designed to monitor and understand the distribution of residual water in the salt as it changes during the testing cycle and to demonstrate and study processes associated with an in-drift emplacement disposal concept that offers superior flexibility and operational efficiency over borehole disposal scenarios.

Although the SDDI conceptual plan and the SDI proposal were developed in parallel with, rather than as an outcome of, the Used Fuel Disposition campaign's disposal research and development (R&D) roadmap exercise (UFD, 2011), it is important to note that the decision to target water movement as a primary process for study is corroborated completely by that roadmap. Using a Features, Events, and Processes (FEPs) methodology, UFD (2011) assigned an overall priority metric for a large number of technical issues across multiple geologic media, factoring in the importance of an eventual safety case at various decision points in a hypothetical repository program. This exercise was intended to guide the Used Fuel Disposition (UFD) campaign's generic R&D program by establishing relative priorities using this systematic process. While it is important to assess the results in the aggregate rather than to focus on the numerical scores obtained, we note that five of the top six issues on the list (of the 210 issues considered) pertained to salt, and four of these are related to water movement in salt: flow through the host rock salt; flow through the excavation disturbed zone (EDZ) salt; effects of repository excavation on flow through the host rock salt; and mineral dehydration salt. The accompanying analysis in the roadmap summarizes these information needs in terms of the uniqueness of water migration in salt relative to other media, and the need to account for the coupled thermal-mechanical-hydrologic-chemical processes and their impacts on repository performance. Clearly, progress in this area will serve the needs of the UFD campaign in its goal of advancing the knowledge base through generic R&D.

The ultimate use of knowledge acquired in this program awaits some fundamental decisions on the nation's path forward with respect to both defense and commercial wastes. For example, with respect to the current policy of commingling defense and civilian wastes in a single HLW repository, and the question as to responsibility for their disposal, the BRC has recommended that the Administration should "launch an immediate review of the implications of leaving responsibility for disposal of defense waste and other DOE-owned waste with DOE versus moving it to a new waste management organization." The report also emphasizes that "implementation of other Commission recommendations, however, should not wait for the commingling issue to be resolved." Furthermore, although the BRC presents a very positive assessment of the WIPP repository as a success story, it is also quick to point out that its charter does not include repository siting or licensing. Given these factors, the approach taken in this SDDI conceptual plan and the previous SDI proposal is to conduct R&D and demonstration tests that would be generally applicable and supportive of the development of a safety case for a salt-based repository, rather than to construct a licensing case for a specific

repository site. With this information in hand, the nation should be able to decide how to proceed with respect to salt repository siting, with a firm understanding of the issues associated with disposal of different types of wastes in salt. Specifically, the salt R&D laid out in the SDDI and SDI programs covers the full spectrum of heat loads anticipated for defense and commercial nuclear wastes, studying the behavior of a salt repository with respect to thermal, mechanical, hydrologic, and geochemical evolution for a realistic and operationally efficient disposal concept.

Figure 1-1 provides a general overview of the relationship between this SDDI conceptual plan and other SDI and SDDI documents and records that have been completed or are planned as a result of this project.

**Figure 1-1: Relationship of the SDDI Conceptual Plan to Other SDI/SDDI Documents**

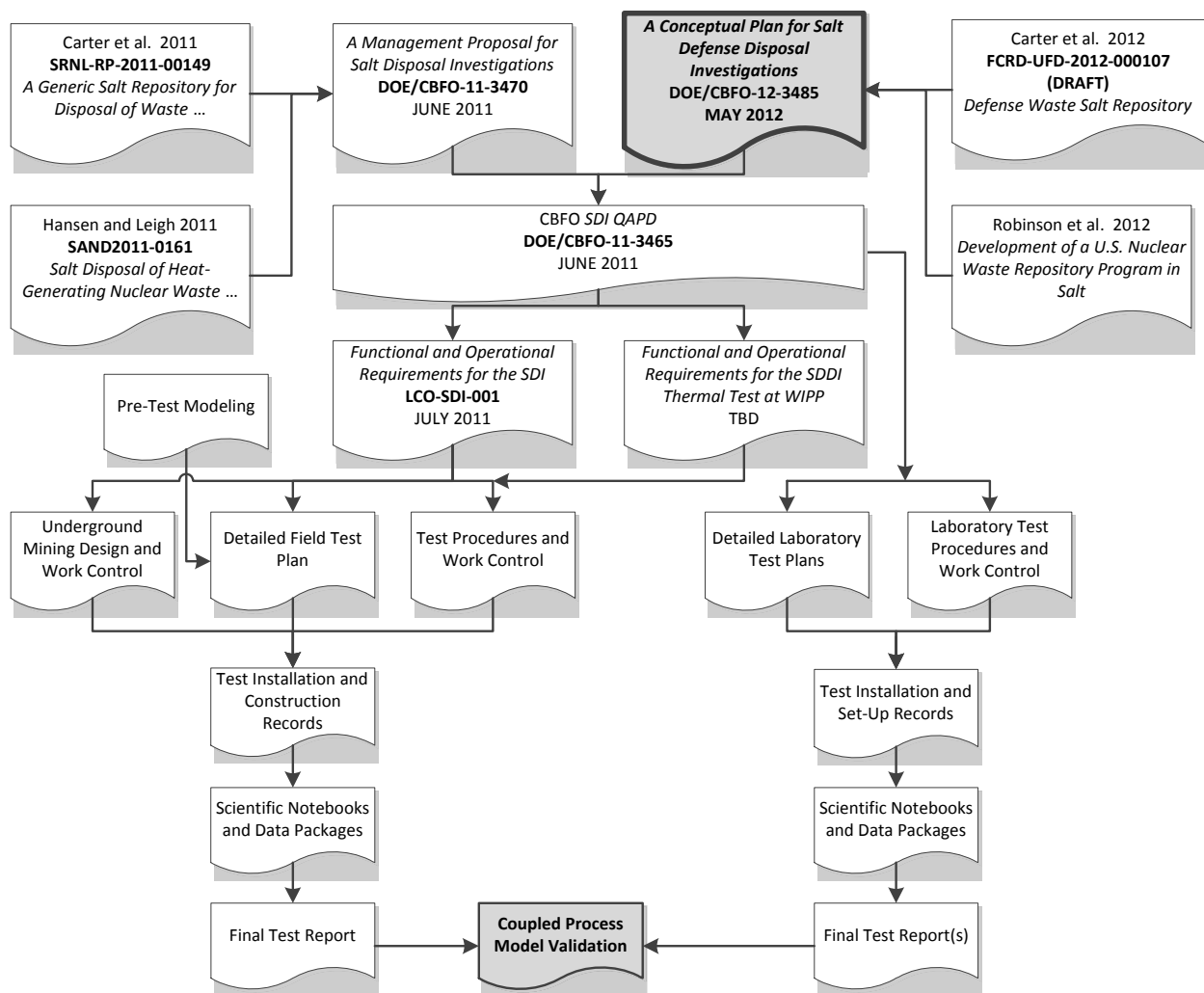

Public understanding and confidence in decayed storage or permanent isolation of radioactive waste in salt have improved as a result of more than a decade of successful disposal operations at the WIPP. DOE-EM and DOE Office of Nuclear Energy (NE) directed research can leverage

this positive experience by reducing uncertainties regarding thermally driven processes involved with decay storage and disposal in salt, further increasing technical understanding for those potential missions. This point is explicitly included in the Memorandum of Understanding between the two offices on the topics of Used Nuclear Fuel and Radioactive Waste Management and Processing Research and Development (DOE 2011a). In collaboration with international salt repository programs, a series of laboratory experiments and simulated heat-generating waste/salt interaction tests conducted over the next several years will answer remaining questions, provide for demonstration of disposal concepts, and more fully inform future repository programs. The proposed work will build upon a foundation of excellence in salt repository applications that began almost 50 years ago.

The WIPP repository was successful because, in addition to a solid science-based safety case, the local community and ultimately the State government supported the location for a nuclear waste repository. To preserve and enhance the enthusiastic support of the local community, and to ultimately gain the support of State and Federal officials, an objective, deliberative process with meaningful stakeholder involvement on a generic salt repository is required. Field testing is a meaningful signal of such a process and such information would provide additional assurance that this type of repository, wherever it is located, would be able to meet performance standards. Field-scale studies, testing, and demonstrations, in conjunction with selected laboratory-scale studies and computer generated models, provide the scientific and engineering base of information necessary to produce the confidence for legislators, regulators, or public stakeholders to make informed, confident decisions.

### **DOE-EM Waste Characteristics**

DOE-EM currently manages the DHLW generated from the reprocessing of nuclear fuel used for defense purposes as well as DOE-owned spent nuclear fuel (SNF), which includes fuel from reactors used for research and defense purposes, fuel from the U.S. Naval propulsion program, and some recovered damaged fuel from the Three Mile Island accident that the U.S. government manages in long-term storage. In contrast to civilian used nuclear fuel (UNF), we retain the commonly used descriptor “spent” to describe these DOE-managed fuels because it is very unlikely that they would ever be reprocessed, even if recycling is adopted for civilian UNF. DHLW in the form of borosilicate glass waste has already been prepared at the Savannah River Site (SRS) and is awaiting disposal in a high-level waste repository. Large quantities of high-level waste are also present in various liquid and solid forms at SRS, Hanford, and Idaho National Laboratory (INL). High-level waste resulting from reprocessing activities at West Valley, New York, is also awaiting disposal (Robinson, et. al. 2012). Table 1-1 and Figure 2-1 illustrate the heat loading considered for disposal as part of the SDDI. Details associated with the defense waste salt repository inventory are contained in the DOE-NE Defense Waste Salt Repository Study (Carter 2012).

Table 1-1: Heat Loads for DOE-Managed Waste Inventories (Carter 2012)

Decay heat per canister (watts)	Savannah River Canisters Number of canisters	All DOE HLW Canisters Cases Number of canisters	All DOE HLW Canisters and DOE SNF Number of canisters	All Navy Fuel, DOE HLW Canisters and DOE SNF Number of canisters
<50	2948	16630	17858	17858
50-100	459	1696	2261	2261
100-220	3891	4414	5203	5203
220-300	0	28	661	661
300-500	264	264	505	505
500-1000	0	0	55	55
1000-1500	0	0	10	10
1500 - 2000	0	0	1	1
>2000	0	0	20	420
<b>Total</b>	<b>7,562</b>	<b>23,032</b>	<b>26,574</b>	<b>26,974</b>
<b>Total Decay Heat (watts)</b>	<b>805,500</b>	<b>1,203,100</b>	<b>1,901,900</b>	<b>3,601,900</b>

Figure 1-2: DOE-EM Projected HLW Inventory

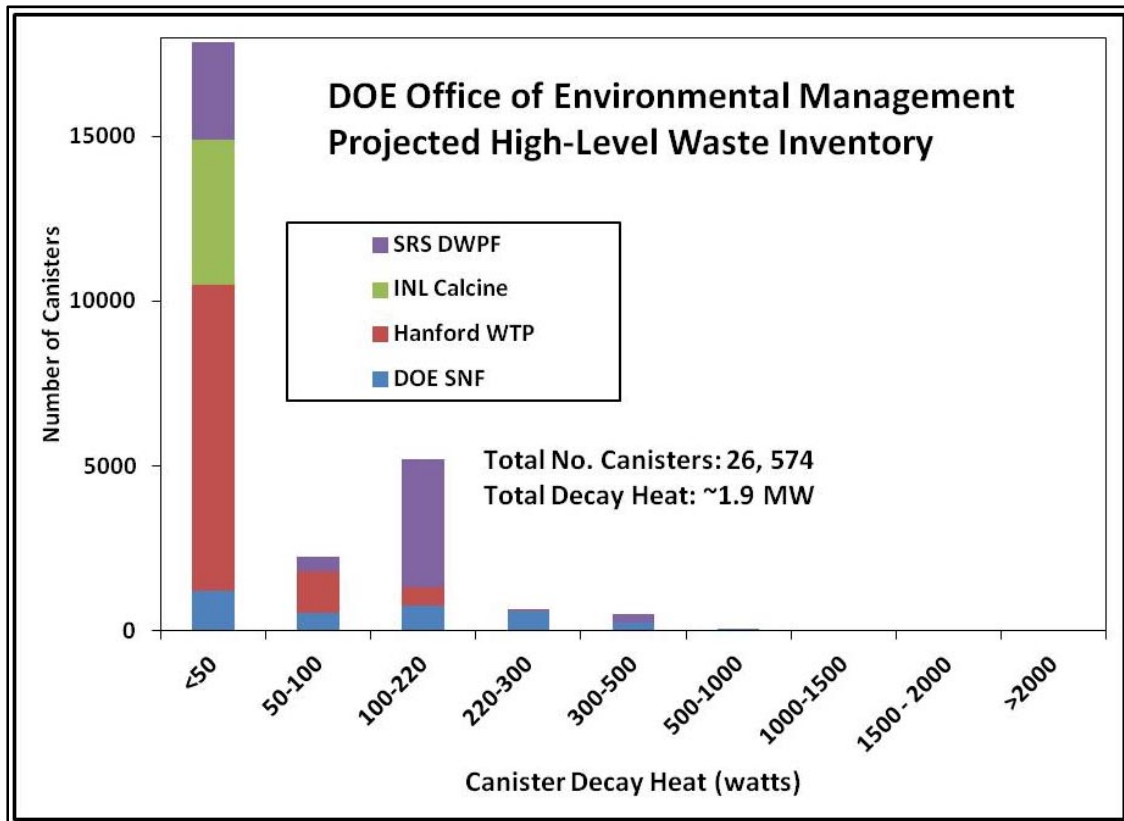

## Civilian Waste Characteristics

Civilian waste consists primarily of UNF from the nation's nuclear power reactors, stored temporarily by the utilities at the site of currently or formerly operating nuclear power plants. The Yucca Mountain Environmental Impact Statement (EIS) categorized the heat loads of disposal packages for the Yucca Mountain repository on the basis of average heat loads across a wide range of fuel burnups and ages. The analysis was designed to enable the average heat load across the repository to be represented, to specify the configuration of disposal packages to be disposed of in the repository, and to ensure that the heat loads were reasonably bounding. Given this purpose, the EIS specified a total of 4239 containers of pressurized water reactor (PWR) UNF with 21 fuel assemblies per container, and 2784 containers of boiling water reactor (BWR) UNF with 44 fuel assemblies per container. The heat loads specified were 8800 watts per container for the PWR UNF, and 6200 watts per container for the BWR UNF; we call these average values the "EIS baseline values." These values mask a broad variability in the heat loads of actual UNF, some of which is much cooler. In general, UNF discharged from commercial reactors in the 1960s - 1980s has much lower burnups than fuel being produced today, a factor that, along with the longer out-of-reactor cooling period, leads to lower heat loads. For example, the 6138 MTHM of BWR UNF and 9,701 MTHM of PWR UNF produced from 1968 to 1987 was discharged with an average burnup of 21,000 megawatts per day (MWd)/MTHM for the BWR UNF and 28,000 MWd/MTHM for the PWR UNF (derived from Notz 1990, Tables 3 and 4). Considering the 50 years of cooling of a low-burnup, older fuel, versus an average design basis of 23-year cooled fuel with higher burnup (33,600 MWd/MTHM for BWR and 41,200 MWd/MTHM for PWR), we would expect some 21 PWR and 44 BWR packages to have heat loads at the time of disposal that are at least a factor of 0.5 lower than the design values used in the EIS, placing these packages in the range of 3100-4400 watts per container. At a finer level of discretization, within the inventory of older, low-burnup fuel, there are portions with burnups much smaller even than these lower average values, implying heat loads that are lower still.

Beyond this analysis, it is possible that the consideration of a new repository might lead to a reconsideration of the number of fuel assemblies packaged in an individual disposal container. Hardin et al. (2011) examined thermal management issues associated with clay, granite, deep borehole, and salt repository disposal concepts, and concluded that for the concepts considered and our current state of knowledge on repository temperature limits likely to be used in repository design, salt is the medium best suited to enable relatively large disposal packages to be emplaced without exceeding temperature limits. However, all media and disposal concepts examined by Hardin et al. (2011) required smaller waste packages: from one assembly per waste container for deep boreholes to 12 or more assemblies per container for salt. Because all of the scenarios examined were for closed repository designs, heat management limitations are more severe than for the open design of the Yucca Mountain repository, which emphasized retrievability and thermal management during the pre-closure period as basic design concepts. Given this result, it is reasonable to conclude that smaller disposal packages (with fewer assemblies per package) could be disposed of in a future salt repository, with the heat load per package scaled accordingly. For example, if the EIS baseline values for 21 PWR and 44 BWR packages are scaled to 4 and 12 assemblies, respectively, the heat loads would scale to values of 1680 watts per container for 4 PWR packages and 1270 watts per container for 12 BWR containers. These values fall within the range of thermal outputs for disposal packages of DOE-EM SNF, and are within the range of thermal outputs contemplated in the intermediate heat SDDI field test.

The purpose of this discussion is to illustrate that although the focus of the SDDI conceptual plan is on defense wastes, the intermediate heat-load thermal test would in fact provide important field-based evidence relevant to commercial UNF, either for older, cooler fuel, or in a disposal scenario in which assemblies are emplaced in smaller waste packages with fewer assemblies per package, or a combination of the two approaches. Thus, the R&D in the SDDI project will significantly advance the scientific basis for both defense and civilian wastes. When combined with the SDI proposal's emphasis on an alcove disposal concept that optimally distributes high-heat waste packages in the repository, the proposed set of tests covers the entire range of thermal conditions likely to be required for all defense and civilian wastes.

Finally, we note that the in-drift concept being simulated in the SDDI field test would lead to significant ventilation of the drift for the time period in which the salt remains unconsolidated. During this period, perhaps lasting several decades, air flow through the system will remove significant quantities of heat and water vapor, influencing the moisture content and the thermal profiles in the heated area. Therefore, the in-drift system resembles an open repository design in which heat and moisture will be expelled from the emplacement drifts: these processes are considered to be advantageous from the standpoint of repository operations. For this reason, we believe that a fairly aggressive heat load in the drift is warranted in the SDDI test, which opens the possibility of disposal of intermediate-heat wastes in the range of 500-2000 watts per container. The crossover heat loads for which alcove disposal would be preferred are at present uncertain, but important information would be derived from the SDDI test to address that issue. Finally, we note that the time period of significant air flow in a disposal operation will be much greater than the duration of the SDDI test, meaning that the demonstration will focus on a quantitative understanding of early-time processes important to thermal management and repository conditions that would then set the stage for predicting long-term behavior of the crushed salt and adjacent intact salt.

### **Why Bedded Salt?**

Almost thirteen years of successful operation of the WIPP have demonstrated the fiscal, operational, and compliance efficiency of salt mining and defense TRU waste disposal. Salt investigations in the United States and Germany support the concept of salt disposal for heat-generating waste as well; however, although there has been substantial work performed previously, both in the United States and abroad, this past work needs to be verified through confirmatory testing, augmented to address specific uncertainties, and augmented to address a specific disposal concept.

The positive attributes of salt that make it an effective medium for disposal and isolation of hazardous, toxic, and radioactive materials have been recognized for over 50 years (NAS. 1957). Very long-lived isotopes present in the waste will be permanently encapsulated in a geologic formation that has demonstrably been hydrologically inactive for hundreds of millions of years, thereby potentially precluding the need for engineered barriers, including vitrification for disposal. As briefly discussed below, the attributes of salt are collectively important to its isolation capability and provide the safety basis for isolation of embedded materials.

- 1) **Salt can be mined easily.** Salt has been mined for millennia. A wealth of underground experience, including TRU waste disposal operations at WIPP, ensures that large-scale, safe mining can be conducted in salt.



- 2) **Salt flows around buried material and encapsulates it.** Salt will slowly deform to surround other materials, thus forming a geologic barrier that isolates waste from the environment. Creep or viscoplastic flow of salt has been well characterized for many applications. Research in the United States, coupled with international collaborations, has played a significant role in development of this technical understanding.
- 3) **Salt is essentially impermeable.** The very existence of a salt formation millions of years after deposition is evidence that water has not flowed through the formation. The established values for permeability of intact salt come from many industry applications, such as the large-scale storage of hydrocarbon product in solution salt caverns. The undisturbed formation permeability of salt is essentially too low to measure using traditional hydrologic and reservoir engineering methods. In undisturbed and healed salt, brine water is not able to flow to waste at rates that would lead to significant radionuclide mobilization and transport.
- 4) **Fractures in salt are self-healing.** In terms of disposal, one of the most important attributes of salt as an isolation medium is its ability to heal damaged areas. Damage recovery is often referred to as “healing” of fractures. The healing mechanisms include microfracture closure and bonding of fracture surfaces. Evidence for healing of fractures in salt has been obtained in laboratory experiments and through observations of natural analogs. Fracture healing can readily restore salt’s low permeability, as noted above.
- 5) **Salt has a relatively high thermal conductivity.** Thermal conductivity of natural rock salt under ambient conditions is approximately 2 to 3 times higher than granite or tuff. A relatively high thermal conductivity is a positive attribute in a salt repository for nuclear waste because the heat is rapidly dissipated into the surrounding formation.
- 6) **Suitable salt formations exist in wide geographic distributions.** There are multiple locations with stable geologic salt formations within the 48 contiguous states (see Figure 1-2) that could host a repository. Salt formations have existed for millions of years in non-seismically active areas. The majority of the salt formations in the U.S. are of the bedded variety and thus offer a broader range of salt body sizes in terms of both areas and volumes as opposed to domed salt.

Figure 1-3: Stable Geologic Salt Formations within the 48 Contiguous States

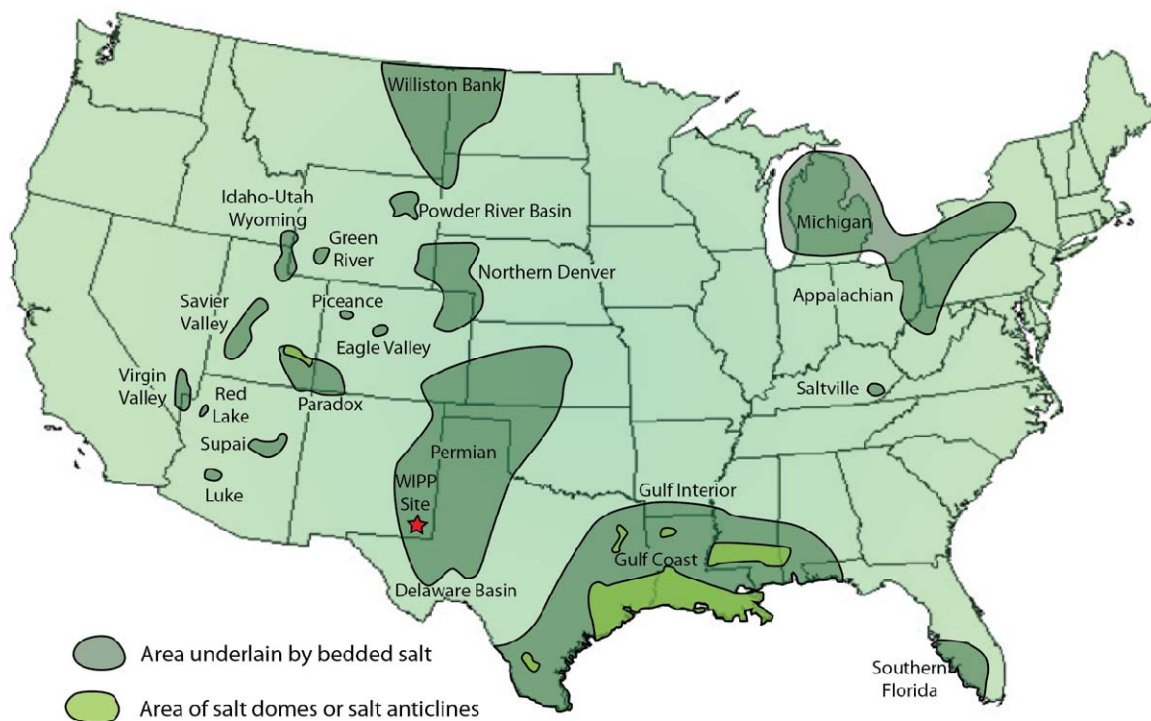

The fundamental studies encompassed in the SDDI and the SDI will be applicable to all salt repository studies. Salt formations were actively studied for repository applications from the late 1960's until the Nuclear Waste Policy Act (NWPA) amendment removed the bedded salt site in the panhandle of Texas from consideration as a civilian repository for spent nuclear fuel and high-level waste. In a global sense, salt mechanical, thermal, and hydrological properties are fundamentally similar. In the early years of site investigations, basic properties of many salts were measured. Some of the other basic phenomena, such as dilatant response and plastic deformation mechanisms, have commonality across a wide range of natural salt.

### **Why Study Bedded Salt at The Temperatures Experienced with DHLW?**

Past field heater tests, many performed at WIPP, have provided significant benefit to our knowledge of salt behavior. As was previously described in the SDI proposal, we should comprehensively evaluate this existing and available information from past thermal experiments to extract the maximum possible benefit from these investments, and to guide the path forward. When the defense HLW test program executed by Sandia National Laboratories (SNL) in WIPP in 1987 was terminated (NWPA Amendments eliminated the Deaf Smith County, Texas, salt repository site), the country lost an opportunity to understand important processes and phenomena for advancing geologic waste disposal. In these initial field tests, researchers gained significant knowledge, but most importantly, researchers "learned what they didn't know," a common outcome when conducting first-of-a-kind experiments.

The test configuration in past experiments was based on the premise of waste emplacement in vertical boreholes drilled into the salt beneath the repository drifts, a disposal concept that, if implemented, could lead to many repository operational limitations and waste containerization restrictions. Earlier work has also suggested that the vertical borehole configuration exacerbates

local pressure gradients and results in high brine inflow volumes and acidic conditions around the hot waste packages, two potentially unwelcome conditions that can be avoided by using the in-drift emplacement design. A key focus of SDDI is to develop and deploy instruments that track water and water vapor movement to validate these assumptions.

Today's advanced computer modeling and data gathering techniques are vastly superior to those used 25 years ago when the most recent WIPP heater tests were conducted. The advent of modern-day computing, advanced geophysical techniques, and advanced geotechnical instrumentation have brought more precise and controlled measuring capabilities that did not exist when many of the test programs were conducted in the 1970's and 1980's. In the intervening years, repository scientists and many others have conducted numerous investigations relevant to the proposed SDDI tests, including 1) flow, transport, and heater tests at Yucca Mountain; 2) vadose zone moisture monitoring in deep vadose zones around the DOE complex; 3) development of electrical resistance and acoustic geophysical methods for remote characterization of rock masses in three dimensions; and 4) computational advances, including High-Performance Computing code development, in the Nuclear Energy Advanced Modeling and Simulation (NEAMS), the UFD campaign, and DOE-EM's Advanced Simulation Capability for Environmental Management (ASCEM) projects. These past and current investments could be leveraged to the fullest extent possible in the development of a modern campaign investigating salt processes for thermally hot wastes.

A demonstration of a proof-of-principle disposal concept, focusing on water movement, would help to clarify our state of knowledge, particularly the understanding of the thermo-hydrologic behavior of heat-generating waste in a bedded salt medium. There is a prevalent conceptual model, espoused by some, that has taken hold in the scientific and popular media (Wald, M. 2009), that posits that fluid inclusions in salt will migrate toward the heat source:

*“Salt is nice, in some senses, from a geologic perspective. But if the salt is heated, the watery inclusions mobilize and flow toward the heat, so burying spent fuel there would require waiting until the hot waste products cool down a bit—somewhere around the second half of this century.”*

These phenomena have been studied for many years in theoretical and laboratory investigations. For example, Shefelbine (1982) summarized the work that had been performed up until that time, illustrating that it is quite possible that the effect described above, as well as other mechanisms that act in both thermal and isothermal conditions, may be inconsequential to performance. There remains great uncertainty in brine and vapor transport due to the complexity of predicting the interplay of multiple processes, as well as issues of scale (Robinson et al., 2012). Testing at the field scale at higher heat loads may help clarify such misperceptions.

A definitive field study on the suitability of salt as a disposal medium, performed, underground in a controlled and cost effective manner at the only permitted salt repository in the nation, will move the country forward in its repository quest. There is sound scientific basis to believe that the introduction of higher heat loads would actually benefit repository performance, as higher temperatures are expected to enhance removal of accessible brine from the disposal system during emplacement operations and pre-closure. Demonstration of the drift disposal concept at intermediate to high heat loads would provide confidence to stakeholders, regulators, and policy makers that salt is a fully efficient medium for these heat-generating wastes.

Field-scale studies and demonstrations, in contrast to laboratory-scale studies and computer-generated models, provide the scientific and engineering base of information necessary to build the confidence necessary for legislators, regulators, or public stakeholders to make informed decisions. Field-testing and full-scale demonstrations provide essential components of such a program.

### **Primary Goals of the SDDI**

The primary goals for conducting this work are:

- **Demonstrate a proof-of-principle concept for in-drift disposal in salt.** WIPP experience has demonstrated that placing waste in a pre-drilled horizontal borehole is cumbersome and difficult. The in-drift disposal concept obviates the need for pre-drilled holes, as well as the difficult phase of waste alignment and insertion into the pre-drilled hole. The proposed disposal concept is simple, safe, and expedient. The outcome of this proposed testing, in concert with the WIPP and analogue repository experience, will allow a more objective evaluation and optimization of proposed future repository designs.

As discussed previously, the majority of past thermal testing at WIPP has been conducted on a disposal concept involving boreholes in the floor. This testing includes studies on the DHLW mockup (Room A) and the DHLW overtest (Room B) at WIPP. The Room A DHLW heater tests were designed specifically to test the waste emplacement configuration consisting of borehole emplacement in the floor of an alcove or room. Room B experiments tested for accelerated closure and the use of backfill materials in the borehole emplacement configuration.

Additionally, although the SDDI testing focuses most strongly on the intermediate heat loads of DHLW and the cooler portion of the civilian UNF inventory, the repository design for heat-emitting waste would need to invoke room spacing and loading strategies that optimize the valuable real estate a repository represents. Thus, the testing is intended to provide the field confirmation for a variety of disposal scenarios, including disposal of multiple canisters of DHLW and/or SNF, disposal of cooler civilian UNF, or disposal of waste packages containing a smaller number of spent fuel assemblies of hotter UNF. The boundary between the thermal limits of in-drift disposal, to be tested in the SDDI field test, and the alcove emplacement concept, to be studied in the SDI field test, is at present unknown; better definition of this boundary would be an important outcome of the full testing program.

- **Investigate the accessibility of brine and its demise in situ.** One of the most important issues in a DHLW repository is the presence and fate of brine that may be accessible. Brine movement is a key phenomenon that has never been extensively studied in past field thermal tests, and not in this proposed disposal configuration. Because brine is key to the evolution of any disposal setting in bedded salt, its movement in this testing milieu (in-drift disposal with a crushed salt backfill) needs to be examined and documented. Brine will be liberated from fluid inclusions and hydrous minerals in the disturbed rock zone and in the region of intact salt that experiences sufficient temperature increase and may migrate if there is a pressure gradient.

The availability and movement of brine and water vapor in a thermally driven salt repository remain uncertain despite some scientific investigation of these phenomena. In an early WIPP Room B thermal test, large amounts of water were collected from one vertical heater hole. As this was unanticipated, a method was developed and deployed during the test in an

attempt to monitor this influx. Because these tests were terminated without full post-test characterization, the unanticipated test result of brine influx was not fully explored, even for the borehole emplacement concept. However, sufficient characterization was performed to show that regions near the simulated waste packages were exposed to highly acidic brine, resulting from the hydrolysis of magnesium compounds in the brine. Therefore, it is prudent to conduct a new test in the proposed disposal configuration (in-drift emplacement) and design brine movement instrumentation and pH measuring equipment directly into the test.

- **Characterize and understand brine liberation and migration.** Small amounts of brine exist in natural bedded salt, trapped since its ancient deposition, millions of years ago. The brine exists in three forms: fluid inclusions, grain boundary brine, and hydrous minerals. Laboratory experiments will be conducted to quantify brine migration and characterize mineral reactions relevant to the water budget. The annulus around a waste package in a vertical borehole is sufficiently small that the migrating brine, released by the pressure gradient imposed by boring the hole, may fill the void space and be heated, producing chemically aggressive conditions. In an in-drift disposal concept, the void space around the waste packages vastly exceeds the expected brine release due to pressure or temperature gradients, so it is likely this is not a problem for this design, but laboratory testing, verified by the field-scale testing, will reliably evaluate this.
- **Develop full-scale response for dry, crushed salt.** Whereas the reconsolidation processes of ambient crushed salt with a small amount of moisture are well understood mechanistically (e.g., Brodsky et al. 1996), the large-scale reconsolidation of hot and dry salt is less well documented. Understanding crushed salt reconsolidation in this setting is essential to establish room closure response, thermal conductivity, and near-field temperatures.
- **Develop a validated coupled process model for disposal in salt for heat-generating wastes.** Iterative field observations and model development will lead to a model that can be used with confidence in future repository design and performance assessment analyses.
- **Evaluate environmental conditions post facto.** After the heating cycle is complete, the test will be allowed to cool sufficiently to allow for the performance of forensic studies of the test bed, the consolidated salt, the location of accumulated brine, and instrumentation condition as the heaters are disinterred.

Motivating this research program is the underlying hypothesis that heat-generating waste may be advantageous to permanent disposal in salt. It will be important to obtain additional information on the performance of heated salt to be able to build a licensing or performance case and to achieve a firm understanding of the prevailing hydrologic and chemical effects during a demonstration of an emplacement concept to provide a basis for a decision regarding disposal of defense wastes. Regarding the SDDI demonstration test, the current conceptual model, which will be subjected to testing at the field scale, is that the crushed salt will remain in a relatively permeable and porous condition during the initial period after heating (or waste emplacement, in the case of an actual repository), leading to the mobilization of water as vapor within the drift. Water entering the drift via the brine migration mechanisms discussed above will be mobilized as vapor along with the water in the crushed salt, leading to redistribution within the drift and an overall drying effect as water is removed in the ventilation air. These effects should be predictable, that is, able to be represented in a thermal-hydrologic numerical model that reproduces the measured behavior. Likewise, drift closure in the field test is expected to be

quite modest. These modeling activities, as well as the extensive geomechanics experience at WIPP, should enable us to predict these small amounts of drift closure expected during this test. Success in these modeling activities, and the accompanying laboratory studies, will enable us to better predict the long-term evolution of the repository environment in the period up to and after repository closure.

With respect to the modeling activities, the directed research will inform, confirm, guide, and ultimately validate capabilities for the next generation of coupled multiphysics modeling. The current state-of-the-art models will be instrumental for layout of the proposed in situ field tests and will continue to provide bases for performance assessments in the future. Next generation coupled thermal-mechanical-hydrologic codes developed concurrently with the planning phase of the field test would then be benchmarked against current codes and validated using the field test data. This research will identify specific requirements for a viable long-term decay storage and deep geologic disposal concept in salt. These key elements would translate into parameters and phenomena to be measured in a proof-of-principle field test. The validated conceptual and numerical models resulting from the effort can then be used in future design calculations or performance assessment analyses.

### **SDI Project Information Directly Applicable to this SDDI Conceptual Plan**

There are many sections and discussions contained in the SDI proposal that are also pertinent to this SDDI program and will be summarized here, but not repeated as a stand-alone section in this SDDI conceptual plan. For example, the SDI Section 1 discussion on “applicability of the SDI proposed work to other salt sites,” and the “relationship of the SDI work to broader repository science efforts,” is directly applicable to this SDDI conceptual plan. Section 2 of the SDI proposal, describing the test management structure, quality assurance, safety, WIPP regulatory compliance considerations, and international collaboration are essentially unchanged for SDDI and are directly applicable.

The overall management of the work proposed within this SDDI project will be through the Carlsbad Field Office (CBFO). The CBFO defines quality requirements through a Quality Assurance Program Document (QAPD) similar to that used for the WIPP program. The SDI QAPD (DOE 2011b) describes an NQA-1-2008-compliant quality assurance program for the science-based studies. The Los Alamos National Laboratory – Carlsbad Operations (LANL-CO) office will function as the project management organization, responsible for day-to-day test management and coordination, similar to a successful model used at the Nevada Test Site and the Yucca Mountain Project, ensuring that all test-related information and data activities are consistent, focused, safe, and of high quality. In its management capacity, LANL-CO will report to the CBFO Project Manager. SNL, LANL, and potentially other scientific entities, will provide Principal Investigators to inform and advise test management to ensure the testing program is as productive, integrated, and efficient as can be achieved. Those portions of the salt investigations funded by the DOE-NE UFD campaign and will be managed according to the judgment of the UFD campaign management team. The WIPP Management and Operating Contractor (M&OC), will provide engineering, construction, and test support labor to provide for the test bed (e.g., drift mining, borehole coring, electrical, and ventilation), and aid in test installation.

Participants in this research will include personnel from LANL, SNL, and M&OC. Personnel at these organizations bring many years of direct salt repository experience and have conducted decades of salt research and thermal testing, both in the laboratory and the field. Experience directly relative to the types of field and laboratory activities described in this conceptual plan

include field work at the Nevada Test Site, large in situ thermal tests at Yucca Mountain, and experimentation at WIPP. In addition, both DOE-NE and DOE-EM, as well as LANL and SNL, have formal technical cooperation agreements with German organizational counterparts performing comparable and complementary research activities. Strong cooperation between Germany and the US, including the active sharing of experiment-based insights, provides yet another dimension of credibility to the results from the work being proposed.

Each SDDI conceptual plan participant has extensive experience and an exemplary record of safety related to field and laboratory work activities, including a culture and value structure that promotes safety in the workplace. Each participant will conduct work safely and responsibly; ensure a safe and healthful working environment for workers, contractors, visitors, and other on-site personnel; and protect the health, safety, and welfare of the general public. This is done through an institutional framework which embodies processes that align with the principles and functions of Integrated Safety Management.

## 2. IN-DRIFT EMPLACEMENT CONCEPT

---

### 2.1. IN-DRIFT EMPLACEMENT VERSUS ALCOVE OR BOREHOLE EMPLACEMENT

The alcove waste-disposal concept of Carter et al. (2011), on which the field test described in the SDI proposal (DOE 2011c) was largely based, innovatively balances safety, ease of operation, and heat management. This concept relies on minimal mining, minimal roof support, use of standard mining industry equipment, and minimal need for specialty equipment.

Because the DHLW waste canisters are not as hot as those associated with commercial HLW, it is not necessary to spread them out into separate alcoves. The DHLW waste canisters can be placed along the length of a drift, one at a time, and covered with salt backfill for shielding, maximizing valuable repository real estate. This in-drift emplacement concept is detailed in the DOE-NE Defense Waste Salt Repository Study (Carter 2012). As shown in Figure 2-1, mining advances one drift ahead of the drift where disposal operations are being conducted. Retreat waste emplacement is conducted in the open disposal drift by bringing in one DHLW canister at a time and placing it perpendicular to the drift, on the floor. The single canister is covered with crushed salt (run-of-mine) backfill for shielding. The angle of repose of the salt (~36°) and the target areal heat loading desired will dictate the location of the next canister, approximately 10-15 feet from the previous. The process is repeated until the entire drift is filled and the backfill is emplaced. Backfill placement can be adjusted such that the canister spacing could be varied to accommodate a variety of thermal areal densities (watts per square meter). Although temperatures and average heat load will be design parameters, the relatively low wattage of the DHLW renders this a relatively minor consideration.

There are several operational advantages to this disposal concept over traditional concepts such as the borehole emplacement method currently used for remote-handled waste at WIPP, several of which would lead to tremendous advantages across the entire waste management system for DOE-EM wastes. In addition, the in-drift emplacement concept imposes few limits on disposal of a wide array of waste forms, container sizes, shapes and configurations. These operational advantages are discussed in more detail below.

**No predrilled disposal holes.** In the development of this in-drift disposal concept, WIPP disposal operations personnel participating in the project pointed out that large operational advantages would accrue from a concept not involving emplacement of the waste canisters in a predrilled horizontal or vertical hole. Operationally, drilling a hole adds a logistical step to the disposal process. Placing a canister in a hole is also time consuming, primarily because of the alignment necessary. Further, wide room spans and/or room heights would be necessary to accommodate the drilling and manipulation of the placement tool. These restrictions would unnecessarily lead to a “one size fits all” approach to the design of the waste disposal container.

In contrast, the in-drift emplacement concept provides considerable flexibility in terms of packaging, containerization, and disposal that would lead to opportunities for efficiencies at all phases of the waste management process: waste processing, transportation, and disposal. Within the repository, design considerations such as the heat loads, multi-canister transportation packages potentially of different diameters, weights, and contents could be accommodated, since in all cases the emplacement procedure is a simple operation. This flexibility should lead to opportunities for cost optimization across the waste management system.



**Rubber-tire versus track-mounted disposal vehicles.** The proposed configuration allows for rubber-tire rather than track-mounted or rail-mounted vehicles to facilitate disposal operations. A rubber-tire fork lift machine could readily haul the payload to its destination in the repository, without the need to construct an operationally onerous rail transport system.

**Straightforward radiation shielding.** The waste would be transported in shielded containers and disposed unshielded. The in-drift disposal concept simply requires that mine-run salt be placed over the disposal canisters to provide radiological shielding. The vehicles that emplace and back away from canisters and move run-of-mine salt over the canisters will need to be remotely operated.

**Narrow room width and height.** The typical continuous miner used at WIPP today cuts nominally 11 feet swaths and can reach nominally 10 feet in height. Therefore, the mining system would involve essentially one-pass vertical mining with a second pass for the ribs (for 16-foot wide disposal drifts). Even with minimal roof bolting, the stand-up time should be substantial for the drifts. Relatively simple modifications to this system could be made to accommodate longer canisters, such as the DHLW canisters planned for the Hanford Tank Waste Treatment and Immobilization Plant (WTP) borosilicate glass waste.

**Efficient, Expedient, and Safe Operations.** A concept that does not require drilling holes and that uses standard industry equipment for placing waste packages in the floor or ribs offers huge advantages. The re-use of shipping containers, made possible by the ability of the disposal concept to handle waste containers of varying shapes and sizes, also offers greatly increased efficiency and tremendous cost savings. In the in-drift concept, workers are protected from radiological hazards during operations by using remotely operated vehicles or shielded vehicles for placement of the packages, and again by covering the packages with crushed salt, providing shielding. This allows workers to be much closer to waste operations (in an adjacent drift) during construction than in other disposal concepts.

## 2.2. THE IN-DRIFT EMPLACEMENT CONCEPT

To conduct meaningful, focused research in geologic disposal, an appropriate starting point is a disposal concept describing the physical configuration of wastes in the underground, and the operations that would be conducted to load the repository. For salt, the favored approach is to select a disposal concept that is reasonably bounding in terms of local and areal-average heat load, is feasible and efficient operationally, and is likely to result in a solid safety case provided that issues identified as uncertainties are addressed.

The in-drift emplacement design concept developed for this variety of DOE-EM managed wastes as described in Section 1 is based on a disposal strategy in which a series of repository panels are constructed underground (see Figure 2-1 for an illustration of the configuration of a single drift and Figure 2-3 for an overview of the disposal rooms). This in-drift emplacement concept is described in additional detail in the DOE-NE Defense Waste Salt Repository Study (Carter 2012).

The disposal operation would consist of placement of one DHLW canister within the drift, on the floor or on a bed of mine-run salt such that it would not roll. Mining operations would be performed on a “just-in-time” schedule such that the waste would be emplaced soon after the mining of a particular drift is completed. In addition, the layout and linear distances of the mined

repository can be controlled to distribute the DHLW heat load, if desired. The DHLW package disposed of in the drift would be covered by crushed salt backfill (using a machine to sling run-of-mine salt on the canisters similar to the one shown in Figure 2-2) to provide radiation shielding for workers conducting operations in the vicinity, including the mining of adjacent emplacement drifts during waste emplacement operations. This strategy is intended to enable a simpler disposal operation with enhanced structural stability.

Figure 2-1: In-Drift Waste Emplacement Concept

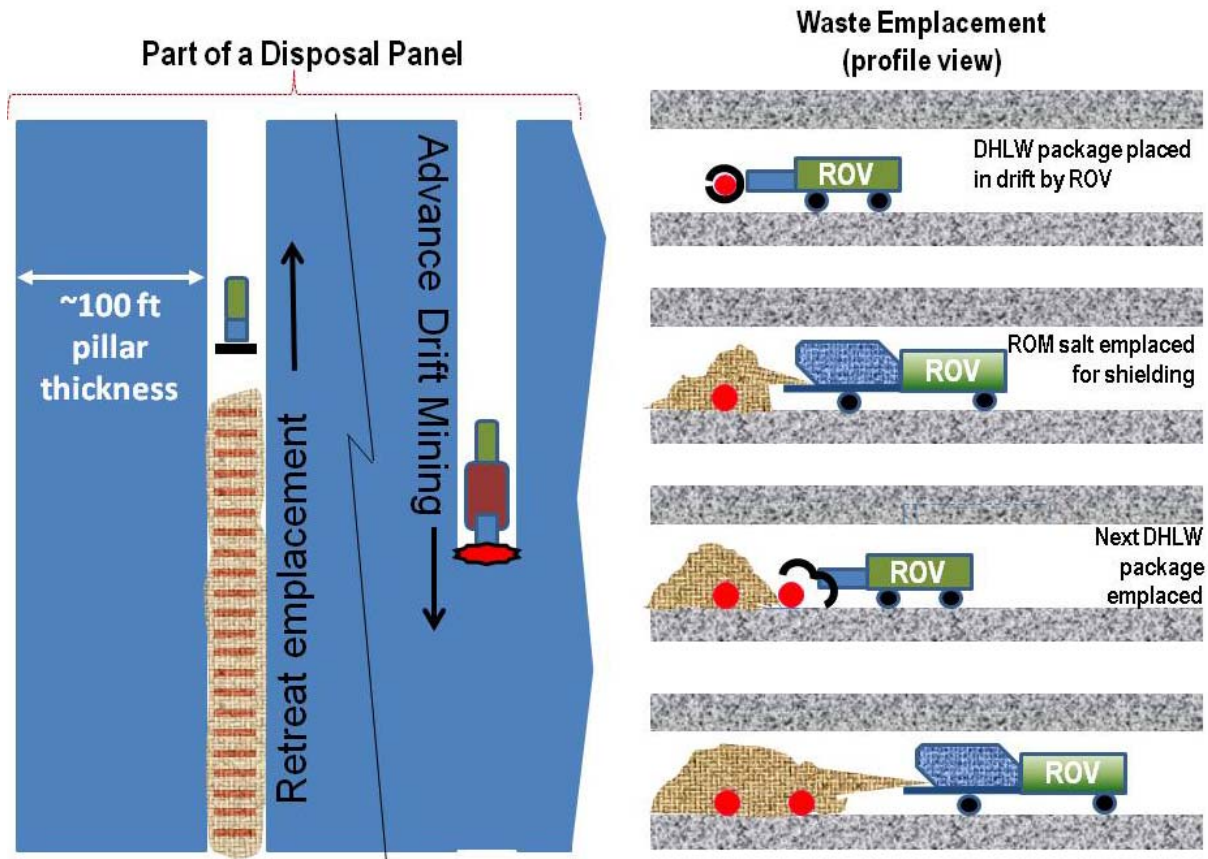

Figure 2-2: Typical Load Haul Dump Configured to Sling Run-of-Mine Salt

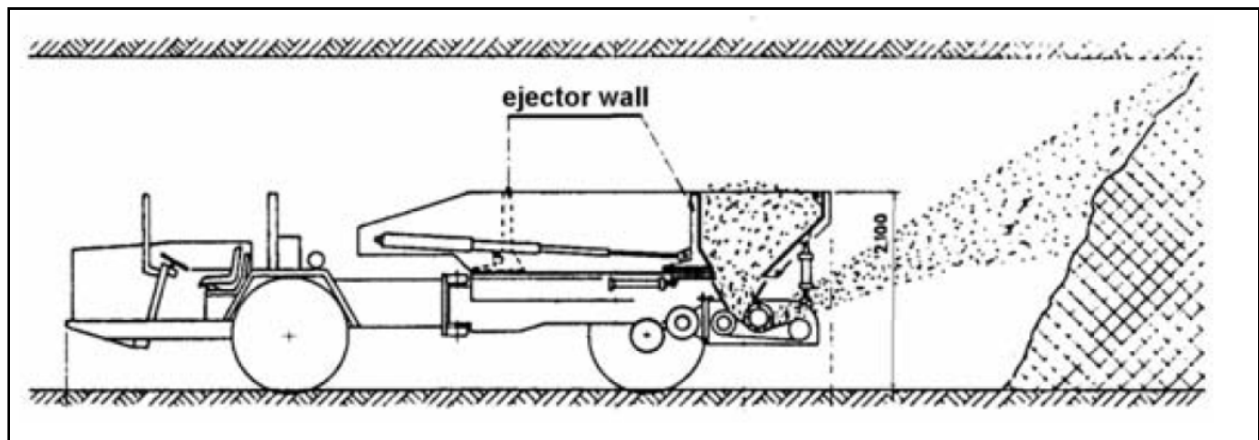
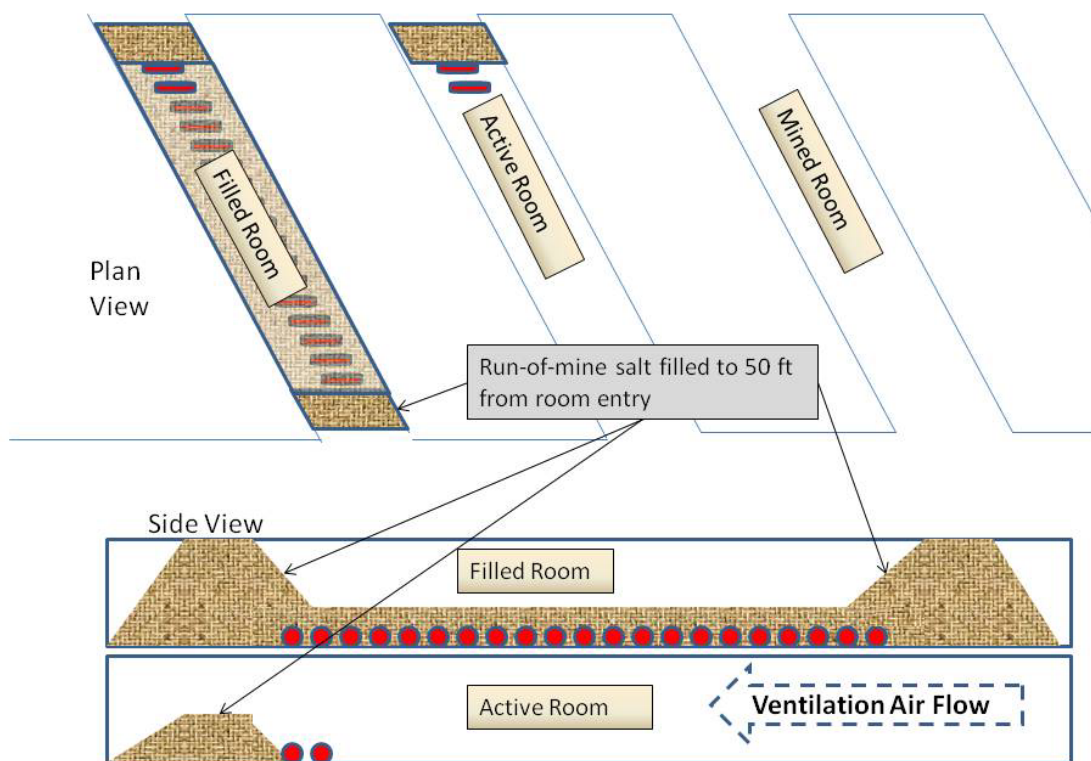

Figure 2-3: Disposal Room Emplacement and Closure



Over time, depending on the physical dimensions and the temperature of the emplacement drift, the salt emplacement drift will slowly deform and surround the backfilled waste packages. The backfill will eventually be in contact with the drift roof, and any forced ventilation provided during the pre-closure period will pass through the salt. This configuration is replicated in SDDI Test Drift #2, as described in Section 3.4.1.

This disposal concept is likely to promote drying of the salt backfill and drift during the pre-closure ventilated period. The amount of moisture removed from the system, and any accumulation along the drift or near the canisters are important phenomena to examine in a field demonstration test. It is advantageous in any repository design, that the waste packages not be subject to a large quantity of brine, thus limiting the potential for corrosion, at least during the pre-closure period when it might be required to retrieve, or in the case of salt, recover the waste packages. Note that retrievability to maintain ready access to a potentially valuable material is a different concept than maintaining the ability to reverse a decision to bury waste because of a flaw discovered in the safety case after disposal operations have begun. An NAS study on “adaptive staging” of repository programs (NAS, 2003) advocated retrievability from the standpoint of ensuring that decisions can be reversed, even to the extent of being able to remove wastes placed in the repository until permanent closure of the facility. In this context, retrieval of waste from a salt repository, if necessary due to safety considerations, is technologically feasible, through a process of locating the waste package and re-mining to recover it. Thus, recovery of waste to reverse a decision due to safety concerns would be achievable, whereas retrieval for the purpose of recovering a valuable resource should not be considered as a viable option for salt, especially since DHLW is not often viewed as a valuable resource, unlike UNF from commercial reactors. Therefore, the issue of retrievability should not be viewed as an impediment to proceeding with a research program for DHLW disposal in salt.

### **3. PROPOSED SDDI RESEARCH PROGRAM**

---

The proposed SDDI program has been divided into four major elements:

1. Functional and Operating Requirements and Test Planning
2. Laboratory Studies to Support the Field Test
3. Coupled Process Modeling
4. Field Test Proof of Principle

#### **3.1. FUNCTIONAL AND OPERATIONAL REQUIREMENTS AND TEST PLANNING**

A first task will be determining Functional and Operational Requirements (F&OR) for the field demonstration test, similar to that done for the SDI field test (LANL 2011), and ultimately, for the integrated URL. CBFO will collaborate with the technical team in the development of the F&OR, as well as assuring that the appropriate breadth of scientific studies is included. The F&OR document provides the general facility and test-related requirements necessary to construct and support a thermal test in the WIPP. Specifically, this document provides the basis for the test bed location, general layout, and field support necessary to plan and implement the thermal test and other investigations. This document will follow an interdisciplinary systems engineering approach for identifying required functionality and documenting requirements. Additionally, sections of the document will provide information related to project execution such as the test description, organization, responsibilities, and schedule.

Test-specific requirements such as parameter identification, data quality objectives, instrumentation, calibration requirements, precise borehole and gage placement, sample control, test procedures, data collection processes, and other test-specific information will be developed and provided in an ensuing detailed field test plan to be developed concurrently.

Laboratory testing and modeling activities will have specific test plans scaled to the level of activity complexity, in accordance with the applicable QAPD. As part of these detailed test plans, existing and available information from past thermal experiments in salt will be comprehensively evaluated.

#### **3.2. LABORATORY THERMAL, MECHANICAL, HYDROLOGIC, AND CHEMICAL STUDIES**

Many of the laboratory testing and modeling efforts described in Sections 3.2, 3.3, and 3.4 of the SDI Proposal (DOE 2011) will be relevant to this SDDI program for those test temperatures and processes that are within the range of interest to DOE-EM managed wastes. The laboratory studies are intimately related to the needs of the modeling program. Experiments to evaluate consolidation of hot, dry, run-of-mine salt, will evaluate a stress/temperature/porosity function that will be used to model elements of the SDI and the SDDI proposed field demonstrations. In addition, an assessment of thermal conductivity as a function of porosity will properly account for the transient evolution of the disposal area: as the mine-run salt consolidates, thermal conductivity increases. Therefore, the thermomechanical laboratory tests on granular salt produce information that is directly applicable to salt disposal of HLW.

Understanding the mobilization of native brine is essential to establish the evolution of the underground setting of this disposal concept. Migration of small amounts of water present within the intact salt, as well as the potential liberation and transport of brine derived from dehydration of hydrous minerals within the interbeds of a halite deposit, must be characterized in order to assess such parameters as the basic amount of brine available to the system and its ability to influence processes. In addition, as the potential carrier of radionuclides, the brine source and transport represent essential components of the repository source term for scenarios in which brine-waste interactions are evaluated.

Closely related to the source and transport of brine is the chemical and material behavior of the brine/salt/engineered materials/waste form system. Laboratory studies on salt and brine will build upon the scientific basis developed for WIPP, and bounding brine and salt formulations will establish the key factors that control radionuclide solubility and mobility at elevated temperatures. The data obtained will be used to fill knowledge gaps in models for radionuclide release for the range of hypothesized intrusion conditions that could be encountered in the disposal of thermally hot DHLW waste in a salt repository. In addition, material interaction data from both the laboratory studies and the field test site will be analyzed, providing data that could be used to assess the compatibility of various waste forms, if warranted.

### **3.3. PREDICTIVE AND COUPLED PROCESS MODELING**

Prediction of the thermomechanical and hydrologic response of the in situ experiment will initially be made by benchmarking calculations using the best-available codes and models. It is anticipated that at least the two major national laboratories will participate in the benchmark calculations, and the international collaborators will be invited to model the benchmark as well. Benchmarking computational capability is common practice in repository programs (e.g., the international collaborations supported under the DECOVALEX project, (Tsang et al., 2008)), and was performed on the WIPP program many years ago, on an international parallel calculations exercise, and more recently by the European Commission for calculations on the BAMBUS II experiment. The benchmark parameters will be established by a technical team. The thermomechanical benchmark modeling cases will use previously completed field experiments at WIPP, such that the initial modeling structure and the parameter values are understood and well documented. However, it is known that there are differences in the constitutive models adapted for the state-of-the-art codes. The performance will be assessed in the benchmark exercise. The benchmark model will be used to inform the field test personnel with regard to placement of instrumentation and sample coupons, as well as to establish the data quality objectives for the main test parameters.

The benchmark models will be confirmed (validated/calibrated) using field test data to match and predict the behavior of the actual system at the drift scale. This work proposes to benchmark and then refine calculational capability for design and analysis of a salt repository. Fully coupled thermomechanical codes will be assessed for the purpose of adding hydrologic behavior. Evolutionary aspects of the accessible brine from the disturbed rock zone couple with the thermal distribution to affect vapor transport.

#### **3.3.1. Pre-Test Predictive Modeling**

Pre-test calculations and modeling is essential to informing field test design personnel with regard to expected full-scale in situ results. This enables informed test planning and will be useful for designing the placement of gages and density of coverage for instrumentation, helping to define the data quality objectives of the test. These

calculations are exercises that simultaneously allow ongoing assessment of the state of the art for models and codes, while providing preliminary results that guide field testing. The modeling process will involve continued refinement as field and laboratory results are acquired, which will allow for improved modeling capability.

As a first step for this conceptual plan, thermal-conduction-only calculations were performed, without ventilation flow, using the LANL porous flow simulator, Finite Element Heat and Mass Transfer Code (FEHM) (Zyvoloski et al. 1997). Future iterations will add air and water transport along with evaporation and condensation, and two-phase flow of air and water with heat transfer by thermal conduction and convection. Conditions will need to be specified for the air flow, including flow rate, temperature, and humidity of the inlet air.

Figure 3-1: FEHM Grid for Conduction Only Calculation

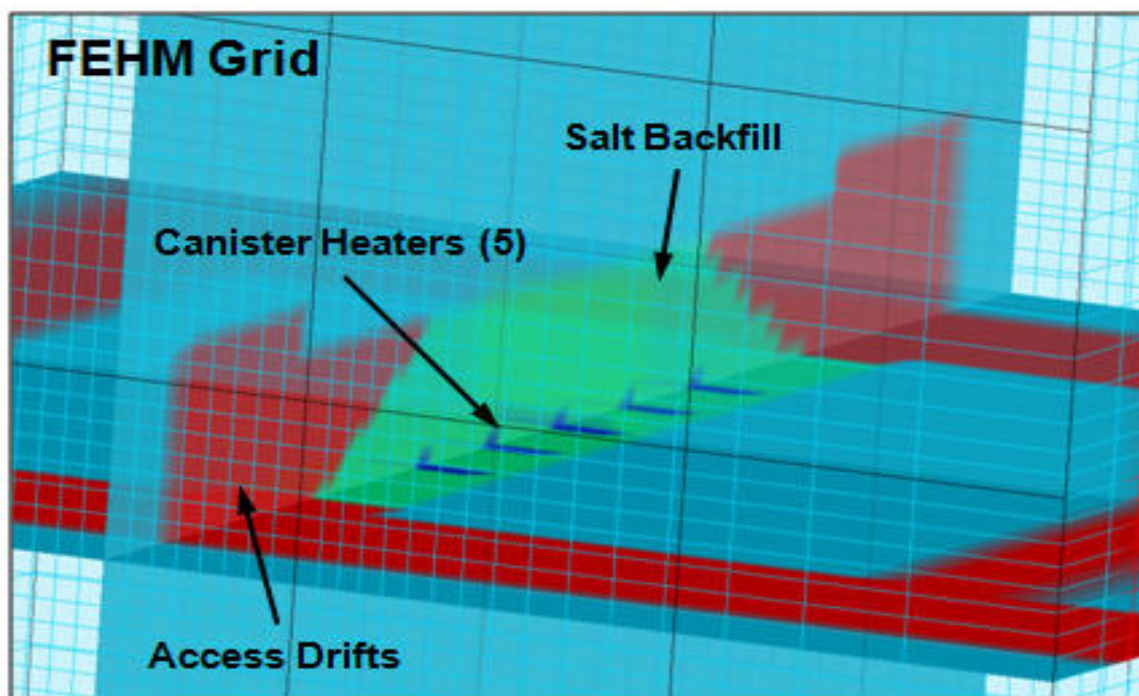

The three dimensional numerical grid for these preliminary calculations is shown in Figure 3-1. The grid is established for the test layout described earlier, with a test drift surrounded by access drifts. Five canister heaters are located on the floor of the test drift and covered by crushed salt backfill. The figure shows zonation of the model, with the open drifts in red, the canister heaters in dark blue, the crushed salt backfill in green, and the surrounding intact salt in pale blue. As a preliminary scoping exercise, three thermal scenarios were examined: all heaters at 500W (Figure 3-2a), all heaters at 1000W (Figure 3-2b), and variable heat, in a pattern of 500W-1000W-2000W-1000W-500W (Figure 3-2c). The figures present the temperatures for a vertical cross section along the drift that cuts through the middle of each heater, after one year of heating. Temperatures are clipped at 100°C in these plots. Of note are the shapes of the isotherms, which follow the irregular shape of the heaters, and define the thermal conditions that the air and water vapor will experience as they transport through the drift.

The results indicate that well within one year, this system is predicted to establish an approximately steady state condition in which heat supplied by the heaters is approximately balanced by thermal conduction to the far field. Table 3-1 lists the temperatures achieved in the middle heater and immediately above and below it in the crushed and intact salt, respectively. Although the grid resolution in these preliminary calculations is too large to obtain a precise estimate of temperatures close to the heaters, it is expected that the temperature at the heater-salt interface to be approximated by the “in heater” value, and temperature sharply decrease to the adjacent values above and below the heater within the first half meter into the medium. Temperatures are controlled locally by the local heat source, attaining values significantly above boiling for the higher heat loads (1000W or greater).

**Table 3-1: Temperatures Predicted for the Preliminary Modeling Cases**

Modeling Case	Temperature, °C		
	In Heater	Above Heater <sup>1</sup>	Below Heater <sup>2</sup>
500W Heaters	82	63	57
1000W Heaters	144	100	86
Variable Heat Loads (500W-1000W-2000W-1000W-500W)	277	167	131
1 Grid node immediately above the middle heater in the crushed salt 2 Grid node immediately below the middle heater in the intact salt			

This preliminary calculation illustrates the modest temperature rise expected in this demonstration of DHLW disposal if the test is conducted at the 500W heat loads. However, for higher heat loads, significant temperatures will be obtained locally, with thermal gradients that will impact the fate of water vapor in the system. Before the detailed plan for the field demonstration is developed, more detailed thermal-hydrologic simulations and coupled structural calculations will be run. In addition, WIPP geomechanics experience will be called upon to set expectations for structural deformation and other data quality objectives.

Figure 3-2: Predicted Temperatures for a Vertical Cross Section Along the Drift

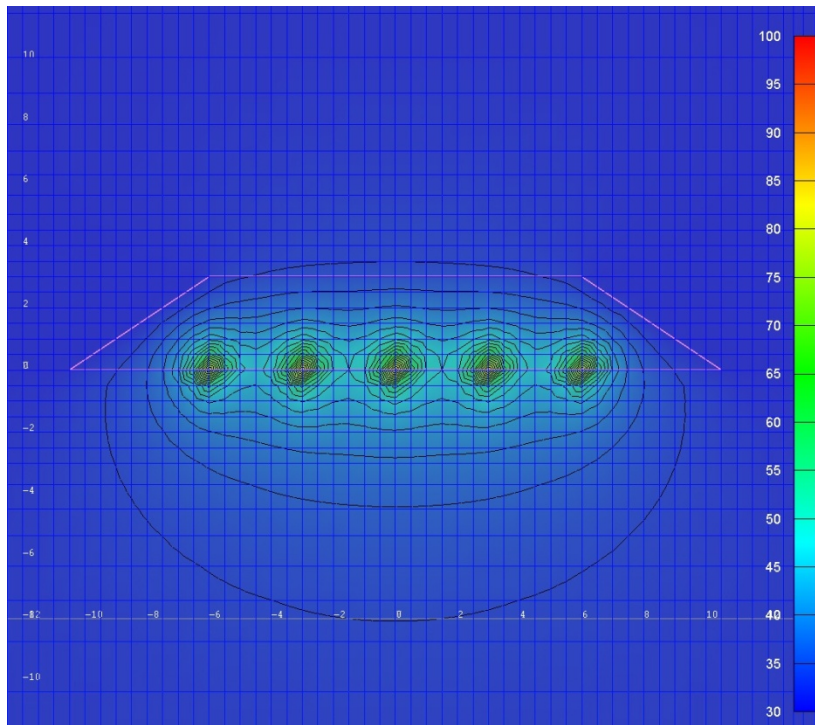

3-2a: 500W from each heater

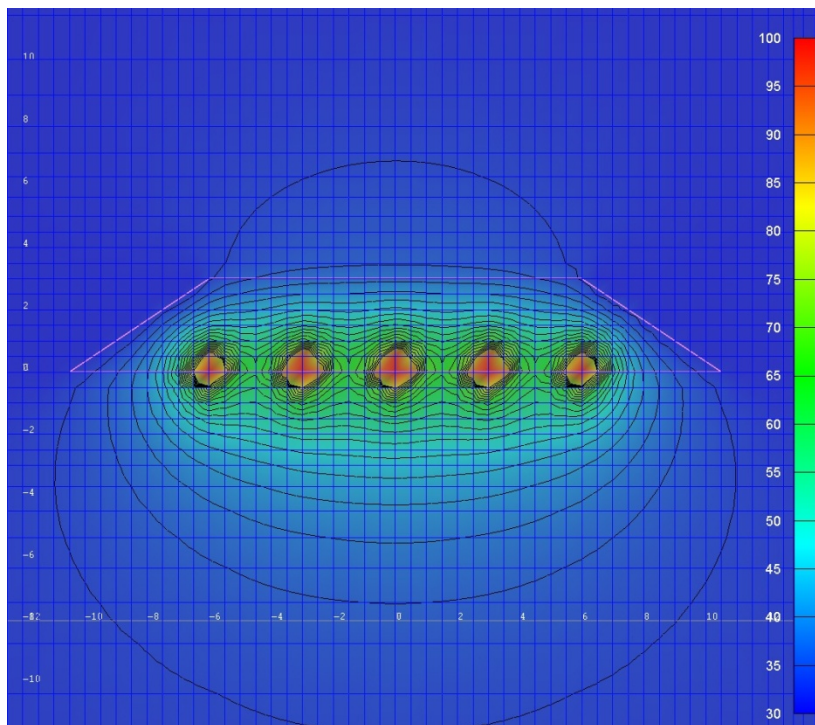

3-2b: 1000W from each heater



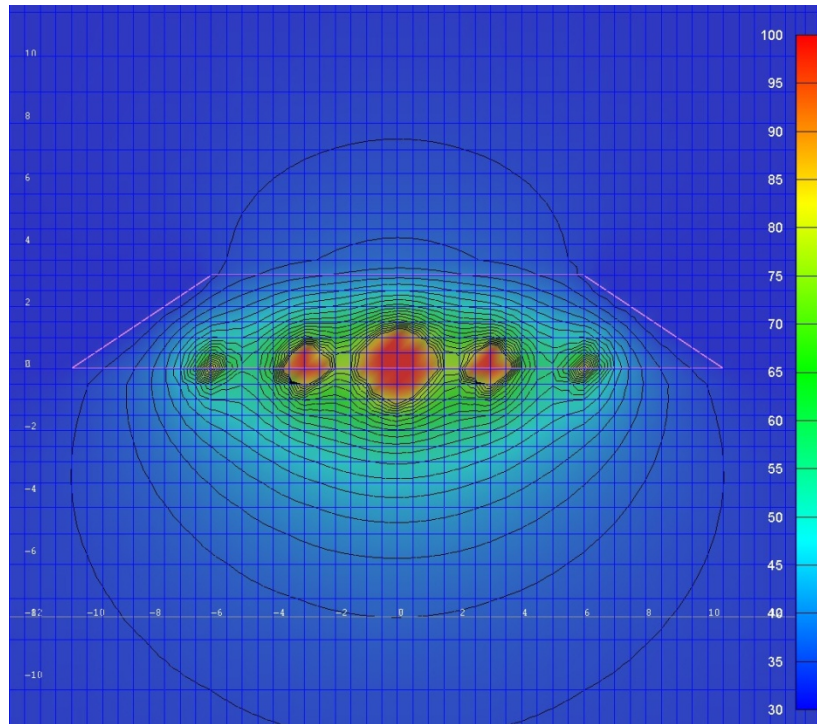

**3-2c: variable heater outputs (500W-1000W-2000W-1000W-500W) along the drift**

Figures 3-2a, 3-2b, and 3-c illustrate predicted temperatures for a vertical cross section along the drift that cuts through the middle of each heater, after one year of heating. Temperatures are clipped at 100°C in these plots: a) 500W from each heater; b) 1000W from each heater; and c) variable heater outputs (500W-1000W-2000W-1000W-500W) along the drift.

These preliminary calculations illustrate the modest temperature rise expected in this demonstration of DHLW disposal. Before the detailed plan for the field demonstration is developed, further coupled structural calculations will be run. In addition, WIPP geomechanics experience will be called upon to set expectations for structural deformation and other data quality objectives.

### 3.3.2. Thermomechanical and Hydrologic Benchmark Modeling

The overall objective of this modeling effort is to inform the field test design and to assess the current capabilities of the thermomechanical computational codes available to solve several complex initial/boundary value problems, which represent heaters, excavations, and back-filled crushed salt of the in situ experiment.

This benchmark exercise will use codes that are appropriate for application to salt repository calculations. Hopefully, several of the most developed constitutive models for thermomechanical and hydrologic behavior of salt can be brought to the benchmark studies through our proposed international collaborations.

This benchmark exercise will use codes that have been developed for other thermal-structural interaction field tests in salt. Benchmark modeling would begin with full-scale field experiments already conducted, and hopefully will be developed in concert with international coworkers. Results of these benchmark studies allow evaluation of computational capabilities, make use of limited ongoing laboratory work, and inform potential design and analysis. The coupled thermal-mechanical benchmark will be performed in three dimensions to calculate the evolution of stresses, strains, dilatant volumetric strains, closure, temperatures, damage and healing, and other phenomena around a potential repository for radioactive wastes in rock salt.

The state-of-the-art for thermomechanical salt modeling involves fully coupled thermal and mechanical response. This involves the rather straightforward calculation of temperature distribution and the more complicated thermally activated creep of salt. After this thermomechanical benchmark is complete, the next progression would involve hydrological response particular to the proof-of-principle disposal concept. The fully coupled thermomechanical codes can be improved by developing and implementing:

- Disturbed rock zone in terms of a damage criterion,
- Consolidation constitutive model for crushed salt,
- Thermal conductivity as a function of porosity.

In the near future, prediction of the thermomechanical response will be augmented by modeling a hydrologic component. This benchmark study provides the foundation for future calculations of brine and vapor transport.

As noted, the primary focus of the benchmark calculations is to inform the field test design personnel with regard to expected full-scale in situ results. The hydrochemical calculation might be useful for placement of gages and density of coverage for certain hydrologic and chemical measurements. Also as noted, the modeling process will involve continued refinement as field and laboratory results are acquired, which will allow for improved modeling capability. These results will be reported in technical publications as the project collects more information.

### **3.4. FIELD TEST PROOF OF PRINCIPLE**

This section describes a preliminary, high-level plan (pre-detailed test planning) to conduct a field test in salt to evaluate its behavior under thermal loads representative of those that would be experienced if DHLW were disposed in salt. To set the stage for this proposed field test program, first, the motivation and the basis for selecting the geometry and conditions of the test is described.

Two of the most important elements affecting the design of a DHLW repository are heat management and the fate of moisture. A disposal safety case, properly conceived and elucidated, relies on well-understood processes attesting to the stability and durability of the geologic barriers to radionuclide migration over geologic time scales. Perturbations caused by the installation of a mined opening or the emplacement of waste must be carefully considered. As such, imposing a limit on the decay heat loading from the waste places limits on the maximum possible areal density of waste, with a significant impact on utilization efficiency of the subsurface facility.

There are several operational bases for imposing a heat-load limit. An additional basis for a heat-load limit is predictability: models used for repository design and performance assessment calculations must be demonstrated to be valid for their intended purpose, to provide assurance that the repository will perform as expected during operations and in the post-closure period. During operation, the stability of the mined facility and the temperatures and radiation environments to which workers will be exposed must be well understood and operations conducted so as to minimize risk to workers and the public. During operations and after permanent closure, parameters such as the maximum allowable temperatures experienced by the waste form, engineered waste package, and the surrounding medium must be established to ensure that the isolation capability of the repository system is not degraded as a result of decay heat and movement of moisture. Because heat is a disturbance from the natural state of the geologic medium, a comprehensive understanding of those changes must be demonstrated, and those changes reflected in validated models of the physical/chemical system, in order to support the safety case for geologic disposal. With confirmation that salt behaves in a predictable way (as demonstrated by a validated numerical model) and that the waste isolation capability of the salt host medium is not degraded relative to isothermal disposal conditions, important strides will have been made in expanding the safety case for salt to include disposal of heat-generating wastes.

The disposal concept being tested, as describe in Section 2.2, facilitates the movement of water as vapor out of the system, at least during the time period when the run-of-mine salt has sufficient permeability to support gas flow by forced or natural convection processes (approximately 30 years in this configuration). Thus, a primary goal of the SDDI field test, as listed in Section 1, is to demonstrate this water movement, and to demonstrate a quantitative understanding through modeling of the moisture data. Although these are not planned to be very long-term tests, previous test results have demonstrated that brine evolution from the salt under a pressure and temperature gradient is highest at earlier times and then diminishes with time.

#### **3.4.1. Conceptual Field Test Design**

The alcove waste-disposal concept of Carter et al. (2011) for high thermal waste innovatively balances safety, ease of operation, and heat management. However, because DHLW waste canisters are not as thermally hot as those associated with commercial HLW, it is not necessary to distribute them into separate alcoves. The DHLW waste canisters can be placed along the length of a drift, one at a time or several bundled into an overpack, and covered with salt backfill for shielding, maximizing the valuable repository real estate, as described in Section 2.2. This in-drift emplacement configuration concept is detailed in the DOE-NE Defense Waste Salt Repository Study (Carter 2012). This test configuration is different than the configurations tested at Lyons, Kansas; Avery Island, Louisiana; or the thermal/structural interaction tests at WIPP. In these earlier tests, live nuclear waste packages (at Lyons) and electrical heaters (at WIPP, Lyons, and Avery Island) were placed in vertical boreholes drilled into the floor of the mine.

To demonstrate the in-drift waste emplacement concept described above, two drifts (each 80 feet long) of minimal cross-sectional dimensions (approximately 16 feet wide by 10 feet high) will be mined. The drifts will be located in the WIPP URL, with the drifts being mined in the northeast section of the facility. The test drifts will be located between access drifts N-940 and N-780, and between drifts E-1550 and E-1460. Figure

3-3 provides a general overview of the test drifts in relation to other features in the WIPP URL. The dimensions and testing horizon are tentative and will be defined in detailed test planning and F&OR development.

**Figure 3-3: Perspective View of the Mining Layout for the SDDI Thermal Test**

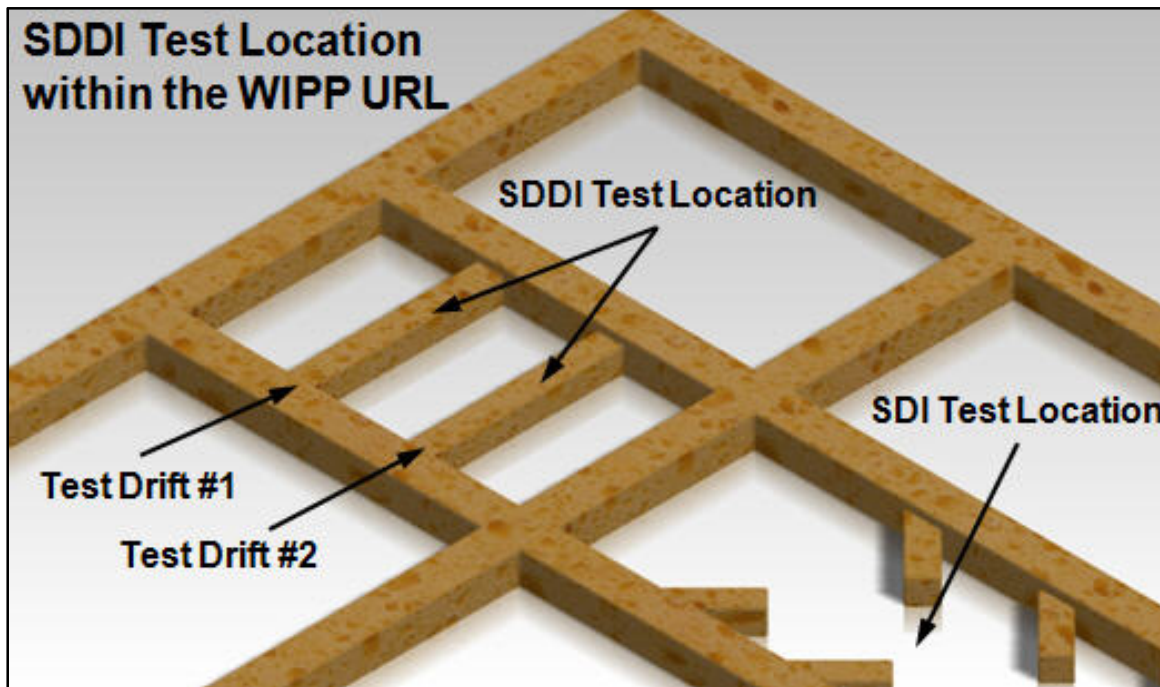

Five canister heaters, likely ranging between 500 and 2000 watts each (compared to approximately 8.5 kilowatts each described in the SDI field test), will be placed on the floor of each test drift, spaced approximately 10 feet apart, center to center. This configuration is preliminary and will be refined during detailed test planning. It is conceivable that smaller wattage heaters spaced closer together may be a preferred arrangement for the test. This wattage range in the heaters would simulate a random distribution of DHLW canisters loaded in the drift at a distribution comparable to that of the DOE-EM managed waste characteristics described in Section 1. At present, during this pre-test planning phase of the program, a specific thermal range has not been specified. As a function of test planning, waste shipment priorities, and modeling, specific thermal outputs or desired areal thermal densities will be established. The test will be designed, both the instrumentation and the heating system, such that it can be adjusted to cover a wide range of temperature regimes as desired. The heaters will have sealed (welded) ends with high-temperature potted electrical leads. The electrical controller will use a step-down transformer to regulate heater power.

In the conceptual layout, both SDDI test drifts will be set up identically, with the exception of the backfill depth. In SDDI Test Drift #1, run-of-mine salt backfill will be placed on top of the five canister heaters in a manner similar to that described in the in-drift emplacement concept. The salt will be laid on the canisters to a depth of approximately 8 feet, without compaction. This arrangement simulates the conditions an emplacement drift will experience, with forced ventilation, immediately following emplacement. In SDDI Test Drift #2, run-of-mine salt backfill will be placed on top of the

canisters to the crown of the drifts. The salt will be artificially compacted during installation to obtain a compressed condition that the backfill in the emplacement concept will likely experience after several years (or more) once room closure brings the surrounding salt into contact with the backfill. In this scenario, the ventilation, instead of flowing primarily over the top of the crushed salt, will be forced to flow through the salt to the exhaust end of the drift. The photograph at the right, taken of testing conducted by Germany's Waste Disposal and Research Program in the Asse mine, illustrates what these conditions (salt backfill placed to the drift crown) likely will look like from the end of the test drift. Section 3.4.5 describes a unique opportunity to gain valuable insight into the techniques and challenges associated with emplacement, instrumentation, and post-test characterization of the run-of-mine backfill through a planned compaction test in WIPP.



**Photo 3-1: Salt Backfill**

In each test drift, a bulkhead will be located at both ends of the drift to control air flow through the drift and allow for measurement of the air characteristics (humidity, temperature, pressure, flow). Both drifts will be heated for approximately one year before a decision is made to either continue the heating or, if enough of the key phenomena, such as the movement and fate of water have been observed and understood, allowing the drift to cool and post-test forensics to be conducted. Figure 3-4 shows a general arrangement of the test layout for SDI Test Drift #2 (backfill to the crown).

**Figure 3-4: Areal View of SDDI Test Drift #2**

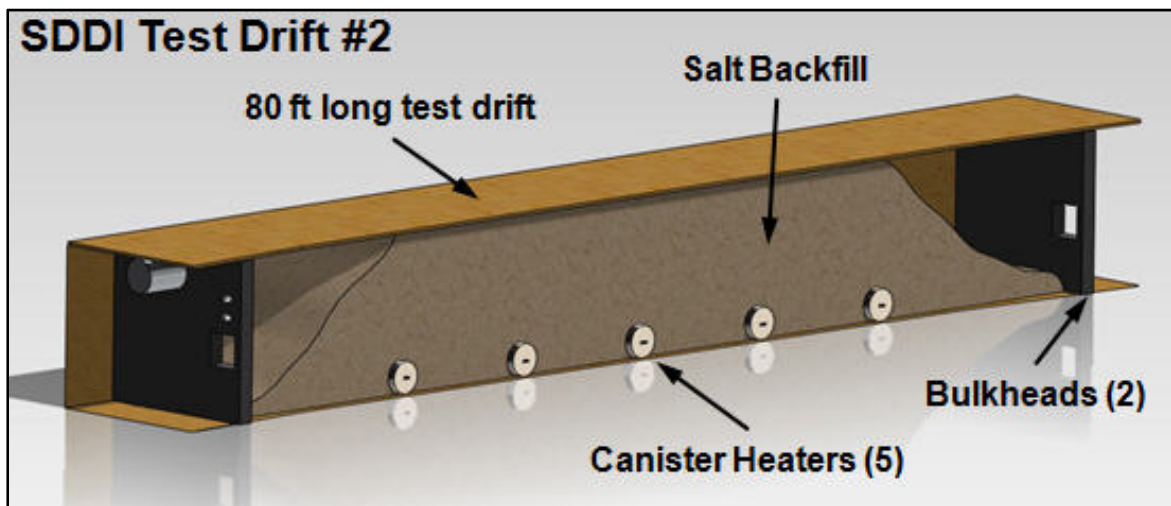

The movement of water and water vapor will be affected by the heat transport from the heater canisters through the crushed salt, and into the intact salt, which consists of a disturbed rock zone, and an unperturbed zone of salt, along with other minerals and marker beds. Ventilated air will pass through the crushed salt, transporting water as vapor, where it will perhaps condense ahead of the thermal front. Alternatively, water will transport as vapor out of the drift and the repository through the ventilation system,

leading to an overall drier condition in the vicinity of the heaters than existed initially. As time elapses, salt deformation leads to a closing of the drift walls and ceiling, and to compression of the crushed salt, although these effects are anticipated to be small in the short time the test is scheduled to run. The crushed salt begins to consolidate in response to this external loading, leading to porosity and permeability reductions over time. Eventually, the consolidating salt will provide back stress, which diminishes stress differences and promotes healing of the disturbed rock zone. Conceptually, the water mass transport rates through the crushed salt depend on the amount of water present, the extent of drift closure, and the degree of consolidation of the crushed salt, which likely depends on the moisture conditions.

Instrumentation of this test concept will focus on the behavior of the crushed salt in the drift, measuring processes and parameters in the drift that provide evidence of water vapor and brine migration, and physical and chemical property changes with time. Initially, there will be a relatively high permeability granular medium, making the backfilled test drifts quite accessible to measurements of a variety of parameters. These parameters include but may not be limited to: 1) large-scale bulk permeability and changes with time that can be monitored continuously (from ventilation flow rates and pressure drops through the crushed salt of known geometry, 2) overall water budget in the vicinity of the drifts (flow rate and humidity measurements), 3) local gas sampling, moisture measurements, pH measurements in liquid samples, and air permeability measurements to obtain the time-varying change in medium properties as a function of temperature, moisture conditions, and deformation, 4) gas tracer testing for direct measurements of porosity, and 5) temperature and displacement measurements throughout the test bed.

#### **Where in WIPP Will the Test be Located?**

Figure 3-5 illustrates the URL area within the WIPP that will support the SDDI field test, as well as the SDI test and other field activities deemed appropriate for development within the URL. Some of the major considerations to the exact placement of the test within the WIPP are: 1) the test must not interfere with WIPP operations, 2) the test should be located to the north, as far from waste handling operations as possible, and outside the shaft pillar area, 3) the test should not interfere with existing scientific testing occurring in the northern part of the facility, and 4) the test should exhaust directly to the exhaust shaft. All of these criteria are met with the design and current construction of this WIPP URL and the placement of this test within it.

The test will be located in a representative selection of salt, characterized during the early mining stages prior to turn-out for the test bed. The test bed will be located approximately mid-way between WIPP Marker Beds 138 and 139. Specific details related to test bed criteria and placement will be documented and transmitted to the construction support organization by way of the F&OR document and detailed field test plan.

Figures 3-6 and 3-7 illustrate the proposed dimensioned layout of the test drifts. Specific details of the in situ heater test will be developed in a formal field test plan based on the F&OR document (e.g., parameter identification, data quality objectives, instrumentation, calibration requirements, precise borehole and gage placement, sample control, test procedures, data collection processes, and bulkhead requirements). The concepts displayed here are sufficient to allow reliable estimates for cost and schedule.

Figure 3-5: Area within the WIPP URL for the SDDI Thermal Test

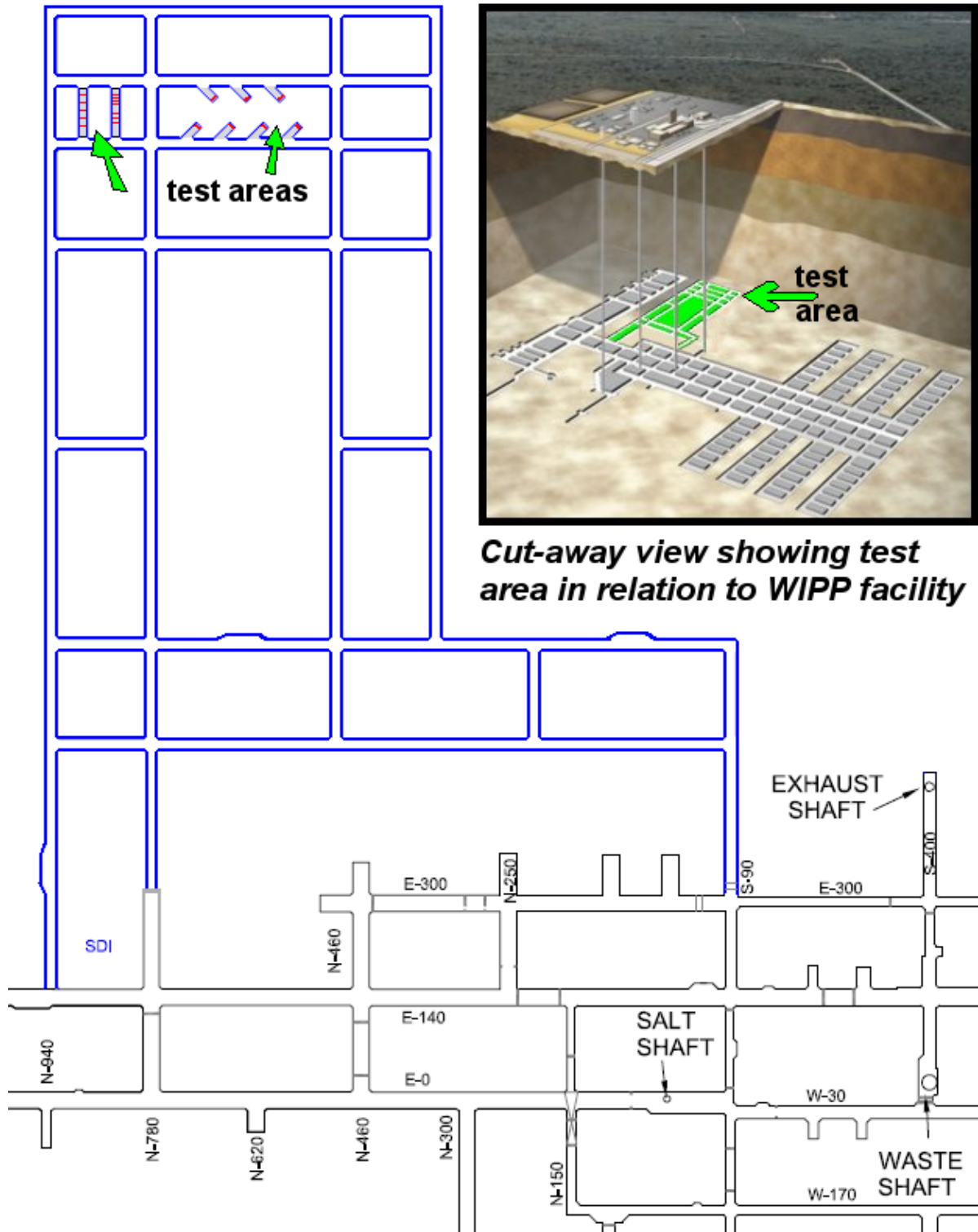

The area in blue illustrates the new excavation planned for the WIPP URL. The area to the far east of the URL is the planned location for the SDI and the SDDI field tests.

**Figure 3-6: Plan View of the Mining Layout for the SDDI Thermal Test**

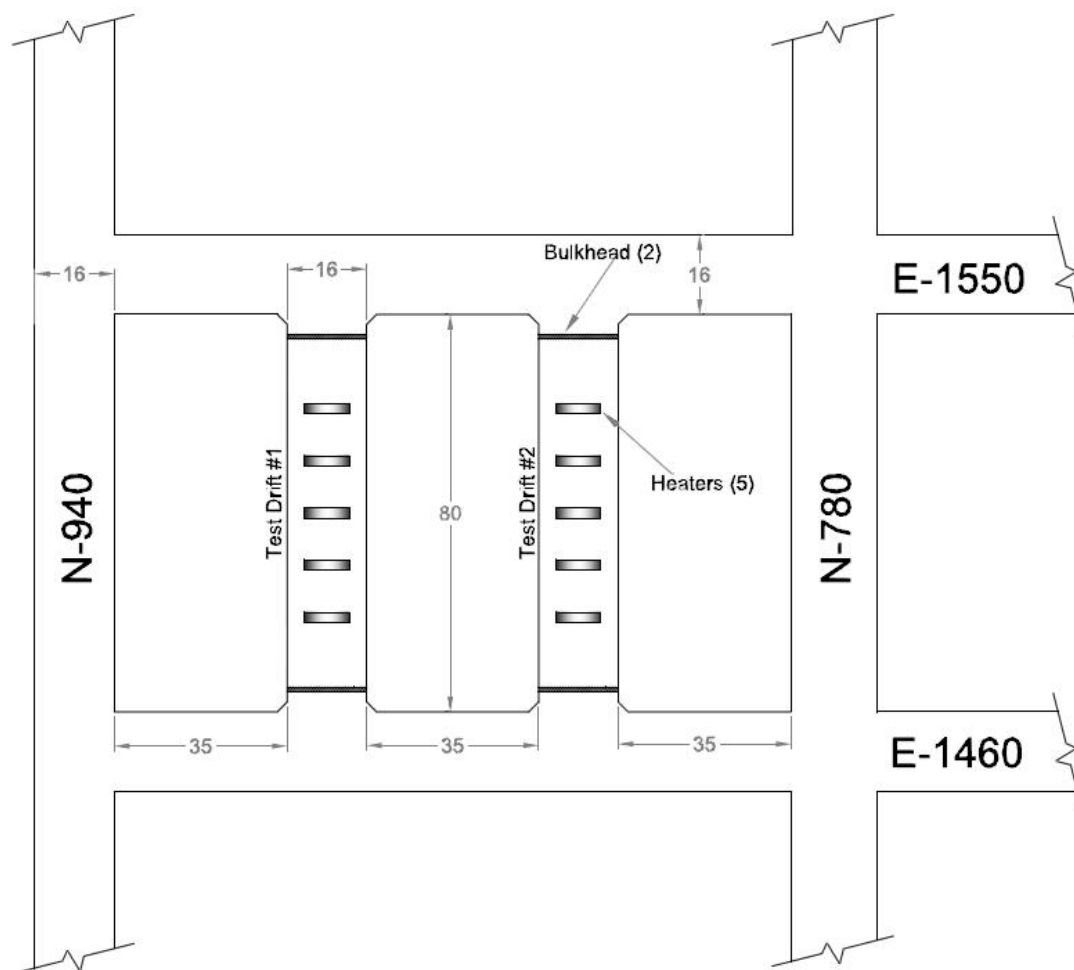

**Figure 3-7: Profile View of SDDI Test Drift #2**

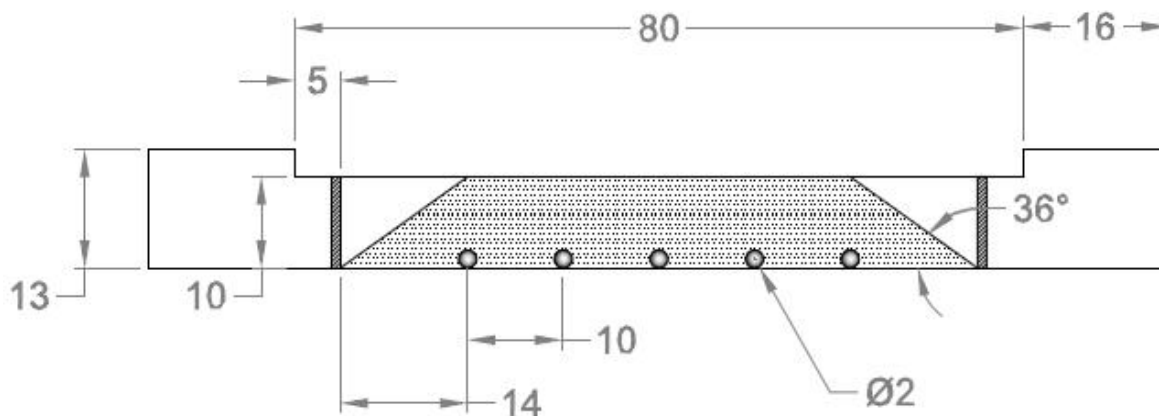

NOTE: Dimensions are in feet. Dimensions are preliminary, not to scale, and for planning purposes only. Angle of repose of the run-of-mine salt is for illustration only. Exact layout and dimensions, including heater wattages and spacing, will be documented in the F&OR document and the detailed field test planning documentation.



The field test will use electrical heaters to simulate the waste packages. Both test drifts will be instrumented to measure brine and vapor movement, temperatures, deformation, closure in and around the test drifts, pressure in the crushed salt, and ventilation conditions, both into and out of the test drifts. Because of the temperature, deformation and brine conditions expected during the test, redundant instrumentation from access drifts, as well as from within the test drifts themselves, will be deployed. Robust signal wiring, including wireless signal transmission, will be investigated and deployed if suitable. Geophysical techniques will be used to assess test conditions whenever possible. Remote visual monitoring through high temperature camera systems will also be deployed. The team intends to include our international peers in review of this test arrangement. Instrumentation considerations are described in section 3.4.4.

### 3.4.2. SDDI Test Parameters

This is a full-scale demonstration of a repository design concept, which in principle will exhibit the operational efficiency of the concept while allowing confirmation measurements of temperature, deformation, and pressures. The disposal concept being tested, as describe in section 2.2, facilitates the movement of water as vapor out of the system, at least during the period when the crushed salt has sufficient permeability to support gas flow by forced or natural convection processes. Experience indicates that the permeability will be very high throughout the short duration of this field demonstration test. The flow through a porous run-of-mine salt backfill and its ability to transport water vapor mobilized by the heat from DHLW canisters of fuel assemblies may be an important design parameter (both in an emplacement scheme and the test design). Thus, a primary goal of the SDDI field test is to demonstrate this vapor and brine movement, and to demonstrate a quantitative understanding through modeling of the moisture data.

The concept for heating each test drift includes an array of heaters with variable power outputs corresponding to typical waste receipt that could be expected from the DOE-EM managed waste inventory discussed in section 1. Each test drift can be designed, both in instrumentation and in heating system, to be heated at a variety of temperatures and areal heat densities, to represent a variety of different waste types. As an example, if the canisters were set at 500 watts each to mimic one of the cases of conduction modeling shown in section 3.3.1, thermal loading pushes the areal heat density to approximately 9 watts per square meter, which will produce temperatures nearing 85°C at the canisters, but likely below 50°C in the spaces between the heaters. These values will be validated and specific heater wattages and areal heat loading values will be specified in the detailed field test plan and informed by the SDDI modeling efforts and priorities associated with the DOE-EM managed wastes.

The test drifts will be instrumented from within, as well as from the adjacent access drifts. Candidate instrumentation can be found in section 3.4.4, with final determinations dependent upon detailed test planning and instrumentation design/development activities. It will be important to understand the temperature regimes in and around the drifts, especially in the salt backfill. The presence, movement, and demise of water in this test are of primary importance, so hydrologic instrumentation will also be installed within the test drift, salt backfill, and in the adjacent salt mass. Inlet and outlet air characteristics will be measured. Mechanical measurements, although not dominant in

this test due to the relative short time period of the test, will be made in the salt and from within the backfill.

As the design of the SDDI field demonstration test is advanced through development of a detailed test plan and F&OR document, it will be important to understand the type of air flow expected from the in-drift emplacement concept. In an actual repository, as described in concept in section 2.2, there would likely be an air gap above the backfill (placed for radiation shielding and not for ventilation purposes). The air flow through this gap would carry heat from canisters below away from the back of the drift opening, and preclude any accelerated closure from above. This is the concept being tested in SDDI Test Drift #1 (see Figure 3-8). However, eventually the back of the drift will close and contact the top of the backfill. Both the drift and backfill would close, and flow through the porous media would ensue. This is the concept being tested in the SDDI Test Drift #2 (see Figure 3-9), with a pre-compacted backfill constructed to the back; however, it is acknowledged that in the relatively short time periods associated with the test, reconsolidation will be minimal. Laboratory testing will investigate this phenomenon.

Figure 3-8: Profile View of SDDI Test Drift #1 with Basic Test Characteristics

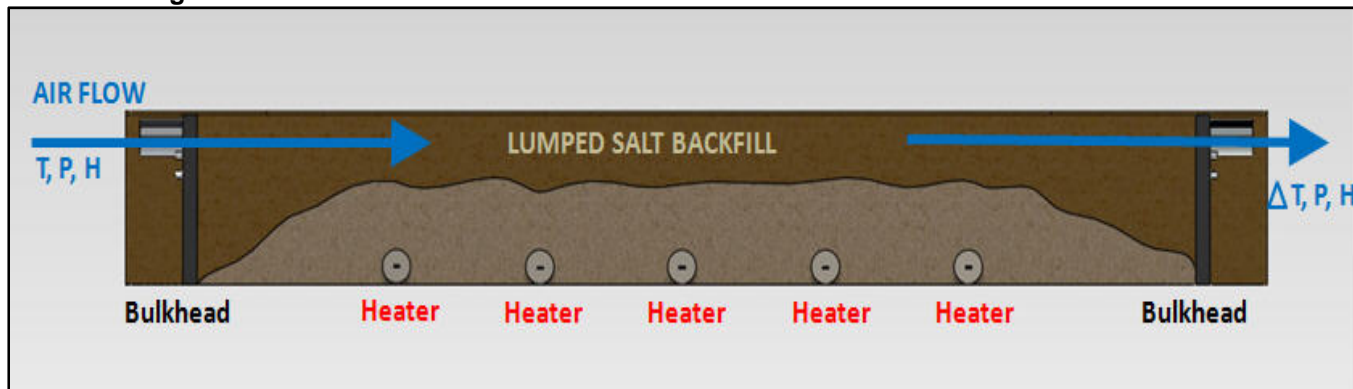

Figure 3-9: Profile View of SDDI Test Drift #2 with Basic Test Characteristics

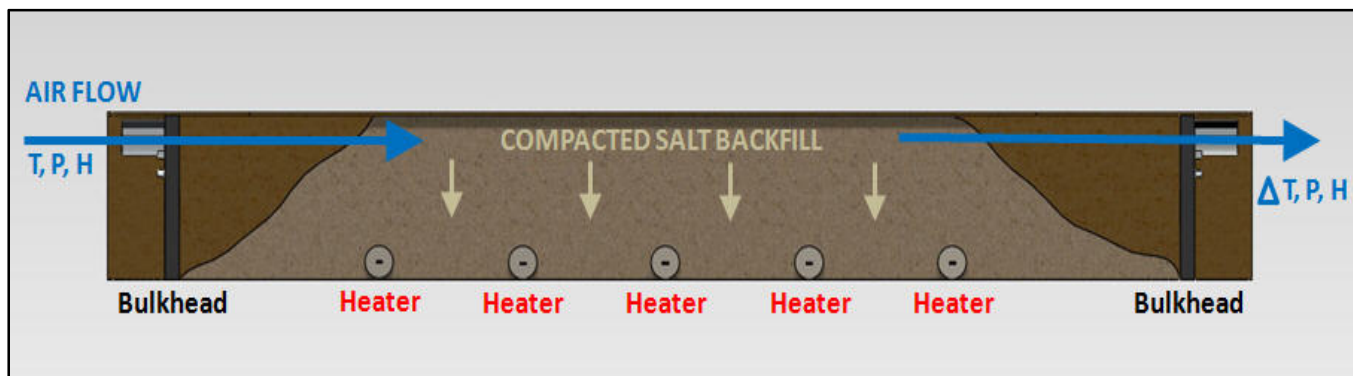

Figure 3-8 illustrates the basic test arrangement for SDDI Test Drift #1 with lumped backfill on each canister. Figure 3-9 illustrates the basic test arrangement for SDDI Test Drift #2 with compacted backfill to the crown of the test drift.

### 3.4.3. Mining and Construction Support

The proposed in situ testing effort requires salt mine access. To aid in determining relative costs, a division of responsibilities has been developed for this conceptual plan as shown in Table 3-1, which delineates the anticipated work breakdown.

**Table 3-2: Partitioning of Responsibilities - Construction & Ops Support and Testing**

Activity	Pre-Test Planning	Const. and Ops Support	Testing
Prepare mine layout and specifications (F&OR)	X		
Define infrastructure needs (air, electrical, communication)	X		
Develop detailed field test plan	X		
Excavate the defined openings (test drifts)		X	
Install ventilation structures and bulkheads		X	
Drill/core instrumentation boreholes		X	
Install instruments in boreholes (e.g., MPBXs, thermocouples)			X
Install data collection system (DCS)			X
Connect instruments to DCS			X
Run fiber-optic cable from DCS to surface		X	
Connect fiber optics to transmitter		X	X
Install electric power distribution		X	
Install electric control panels and heater controllers		X	
Install heaters		X	
Provide underground compressed air		X	
Routine supply delivery (aboveground to test area)		X	
Special equipment delivery		X	
Facility management and science program interface		X	
Test coordination, oversight and facility interface			X
Install ventilation monitors		X	
Install instrumentation			X
Install heaters in test drifts		X	
Cover heaters with mine-run salt		X	
Install instruments in mine-run salt		X	X
Daily heater power inspection/regulation		X	
Instrumentation and DCS maintenance			X
Collect and analyze test data			X
End of test forensics, recovery, and decommissioning		X	X

Section 4 of this conceptual plan provides the cost and schedule estimates for this workscope. The estimates for mining and infrastructure are from direct mining experience at WIPP. The operating WIPP facility provides advantages in terms of operating infrastructure, Mine Safety and Health Administration (MSHA) qualification, equipment, and resources. The field experiment will not interfere with the WIPP operations or the greater WIPP mission.

The labor and infrastructure associated with mining and engineering at the WIPP are existing WIPP resources and will not require new SDDI budget. Those total costs are accounted for, but not included in the new SDDI specific budget necessary to complete the work. Consumables and equipment (e.g., ventilation control, power distribution, the

purchase of a new core rig) are included as direct costs requiring new SDDI budget. The cost estimate also includes forensic back-mining in the last year of the project to retrieve instrumentation, salt samples, and the heaters for laboratory analysis and determination of in situ drift environmental conditions, mineralogy, and brine chemistry.

The total distance mined for the two SDDI test drifts for the basis of this estimate is approximately 160 linear feet at approximately 16 feet wide by 10 feet high. Approximately 10,000 total linear feet of mining (approximately 16 feet wide by 13 feet high) is required in the north section of the WIPP in order to gain access and properly ventilate the test area. Each test drift will be backfilled with run-of-mine salt after the heaters are placed in the drift as shown in Figure 3-4. Whereas the detailed field test plan will have exact layouts and dimensions, it can be expected that there will be approximately 25 boreholes per drift (cored from both inside and outside the drift, many from the adjacent access drifts). If each borehole was an average of 30 feet long, an approximate total of 1,500 linear feet of precisely placed boreholes will be required to field this test.

An assumed configuration of five heaters (per test drift) at intermediate heat loads, if operated between 500 W – 2,000 W, will require a power load between 2.5 kilowatts and 10 kilowatts. The instrumentation, equipment, lighting, and general power will require approximately 10 kilowatts clean 110V/220V single-phase power.

#### 3.4.4. Instrumentation for the Field Test

The instrumentation of the SDDI thermal test is expected to be a complex process involving several steps. First, gages will be selected that can accurately measure the anticipated range of responses in the test and withstand the anticipated harsh test environment for several years. In order to ensure test accuracy, the gages will be calibrated before use and will be installed within a surveyed coordinate system specific to the test drift. Gages will be monitored by a data acquisition system and data placed in a database to facilitate data reduction and analysis. The gages, as feasible, will be maintained on a regular schedule to ensure long-term success for the experiments (Munson et al. 1997; DOE OCRWM 1998). These testing activities (including gage calibration) will be performed according to established SDDI quality assurance procedures. Past salt testing experience has proven that with redundant instrumentation, robust gage design, pre and post-test gage calibration, and gage maintenance where feasible, will lead to successful application of sensors despite a harsh environment application (Droste 2003).

An important test parameter associated with this experimental work is brine and vapor movement in the salt formation during the duration of the demonstration test. These measurements are generally not as straightforward as monitoring for temperature or ground movement. Additionally, the ground movements and brine conditions expected to be observed during this demonstration test will make it imperative that measurement techniques account for these potentially adverse conditions. As such, new or more advanced techniques are likely to be developed and employed in this field test to measure, at a minimum, vapor and brine movement.

Geophysical techniques (in addition to the more traditional instrumentation listed on the following pages) are expected to be developed, demonstrated, and potentially deployed to monitor salt drift properties important to the test. A period of one-year duration at the

beginning of the time-line is set aside to develop and demonstrate these geophysical measurement techniques, including the more conventional monitoring instrumentation that will measure salt drift properties. All of the geophysical measurement methods are proven, but some are site or application-specific. They are well established techniques, but some may not be appropriate for this salt testing program due to such issues as minimum spatial resolution and limited sensitivity to contrasts between solid, fluid and vapor phases in the salt. For these reasons, there is uncertainty associated with applying these techniques to fluid and vapor migration in salt. Therefore, the planned demonstration period at the beginning of this test program will be used to develop advancements that address the resolution and sensitivity issues.

The following section discusses instrumentation anticipated to be candidates for the SDDI field demonstration test as well as some of the geophysical techniques being considered. This is not a comprehensive list and several different types of instruments may be available for each need. Each measurement technique will be thoroughly investigated during the instrumentation development period as a function of detailed test planning. Lessons learned from past testing completed at WIPP, the Yucca Mountain Project, and salt testing performed internationally will be considered. Some of these lessons learned are discussed below. Information exists on each these measurement techniques and its application to the anticipated test environment; however, in the interest of brevity, only a summary is provided on each.

### Temperature Measurements

Temperature measurements in this test should be straightforward. Most of these sensors are commercially available, proven technology, and reliable in these test conditions. A large quantity of these types of sensors will be installed within the test bed to measure the temperature of the canisters, the salt backfill, the intact salt, the air within the test beds, the temperature of the bulkheads, the temperature of the inlet and outlet air, and for thermal compensation of other instrumentation (e.g., extensometers). Candidate instrumentation for obtaining thermal data is as follows:

- **Thermocouples/Resistance Temperature Detectors** – Used previously in WIPP thermal experiments, premium grade, Type-E thermocouples with ungrounded junctions, high purity magnesium oxide insulation, and Inconel 600 sheathing were selected for use in the tests due to the hot, humid, and salty environment. "Premium grade" denotes conductors made of high-purity alloys that ensure greater measurement accuracy, while "Type-E" denotes junctions of chromel and constantan conductors. It will be imperative that the thermocouples are well sealed to prevent moisture invading the insulation.

Resistance Temperature Detectors (RTDs) measure temperature by correlating the resistance of the RTD element with temperature. RTDs are often more accurate temperature sensors than thermocouples and provide excellent stability and repeatability, but can be more fragile and come with fixed lead lengths, making their placement in the test bed more dependent on up-front test design.

Thermocouples and/or RTDs will be used to measure temperatures within the drift, on the heater canister, in the salt backfill if carefully placed, and in boreholes to measure temperatures both in the near and far-field.

- **Fiber Optic Temperature Array** – Fiber optic distributed temperature sensing is an emerging technology that involves sending laser light along a fiber-optic cable. Photons interact with the molecular structure of the fibers, and the incident light scatters. Analysis of backscatter for variation in optical power allows the user to estimate temperature. Commercially available detectors can achieve a continuous measurement over long distances (kilometers), with special resolution of about a meter and thermal resolution of about 0.01 degrees. This technology might be considered for temperature measurements within the salt backfill as a mesh might be laid down as the backfill is emplaced.

### Mechanical Measurements

Mechanical measurements will be made in the intact salt mass surrounding the test drifts as well as within the salt backfill itself. Because of the relatively short time frames and lower temperatures (compared to the SDI program) planned for these SDDI field tests, there is not expected to be significant drift closure during the testing period. These mechanical measurements will be conducted to confirm this hypothesis. Because drift stability and mechanical deformation in salt is well understood, comparison of these measurements will be made to existing thermomechanical models as well as past observations and data. These measurements should be straightforward and a great deal of knowledge exists from their use in past thermal studies in salt.

- **Multi-Point and Single-Point Borehole Extensometers** – Used previously in WIPP thermal tests, extensometers monitor rock mass extension by measuring the relative displacement between an anchor set at some depth in a borehole and the borehole collar. This can be done with a single anchor or multiple anchors set at different lengths. These are often installed in an array around the room with anchors set at varying depths up to 50 feet. The photo at the right shows a field technician emplacing a multi-point borehole extensometer (MPBX) anchor and rod into a borehole.



Photo 3-2: MPBX Installation

- **Room Closure Gages** – Displacement transducers provide remotely monitored room closure data and were used extensively in past WIPP thermal tests. Typically, the closure gages are physically linked to extensometer heads at opposite sides of the test room. The transducer is attached to one extensometer, while a span wire is stretched across the room and attached to an eyebolt on the other. These can be installed in both the vertical and horizontal orientations at a station. If an extensometer is not co-located at this location, the gages can be anchored directly to the formation using a transducer bracket on one side.
- **Active time-lapse in situ seismic wave transmission measurements and monitoring** – Active seismic methods are the primary geophysical tool that could remotely, noninvasively detect subtle thermal/mechanical changes within the test area. The velocity at which seismic waves travel through solid material varies with

density, temperature, and pressure. The density, wave scattering properties, and energy dissipation of the material also change with temperature. Thus, spatial variations in the travel time, scattering, and attenuation of seismic waves can be used to map changes in seismic wave velocities, material density, heterogeneity, and viscoelastic properties caused by temperature gradients in and around a heated region of salt and/or brine and vapor movement. One method that may be used is known as seismic tomography and is similar to techniques used in medical X-ray diagnostics. Full three-dimensional coverage of the region surrounding heated drifts with appropriate seismometers or accelerometers would allow detailed tomograms to be obtained using active seismic data acquired at different times, which would illustrate how the spatial temperature profile around the heaters evolves.

- **Pressure Cells** – Borehole pressure cells (BPC) have been used to measure stress change in a wide variety of rock types. A BPC typically consists of a flat metal chamber filled with a fluid that has a transducer connected by a tube; the transducer converts force into a measurable electrical output. The cell is inserted into the media (borehole or crushed salt backfill), and pumped up to create contact with material to be measured. The BPC responds primarily to stresses acting perpendicular to the plane of the flexible plates, but also has a small sensitivity to stress changes in the plane of the flexible plates. Two cells installed in a borehole at right angles to each other will provide orientations of the principal stresses in the plane perpendicular to the axis of a borehole.
- **Passive Seismic Event Monitoring** – The deformation induced by heating the salt will likely result in multiple scales and degrees of brittle failure of the alcove structure and surrounding formation. During initial heating, small-scale deformation might occur along cracks or fracture planes, either by crack growth or by slippage along pre-existing planes of weakness. These discrete events will result in very small microseismic or acoustic emissions. As heating progresses, large-scale fracturing can occur in the salt alcove walls, ceiling, and floor. Data from these events can be used to determine the location, development, and extent of the fractures, as well as the fracture mechanism itself. The microseismic data would provide an important measure of how thermal-induced strains are accommodated discretely in the salt body and how they lead to major structural events. A passive seismic monitoring system will provide insight into the presence and source of brittle phenomena.

### Hydrologic Measurements

Hydrologic measurements will be a key component in determining the water movement expected during the demonstration test. These will be challenging measurements that most past thermal tests in salt did not prioritize during the initial design of the test programs. There are several candidate techniques that may be employed, but each will require adequate upfront preparatory time, including laboratory work to demonstrate and refine the techniques. Moisture measurements will be prevalent throughout the test, concentrating on measurements in the salt backfill and in the intact salt near the heaters.

- **Time Domain Reflectometers** – Time domain reflectometer (TDR) probes can be inserted or buried in the crushed salt or intact salt to be measured. The TDR is a wave guide extension on the end of the coaxial cable. Reflections of the applied signal along the waveguide will occur where there are impedance changes. The impedance value is related to the geometrical configuration of the TDR (size and

spacing of rods) and also is inversely related to the dielectric constant of the surrounding material. A change in volumetric water content of the medium surrounding the TDR causes a change in the dielectric constant. This is seen as a change in probe impedance which affects the shape of the reflection. The shape of the reflection contains the information used to determine the water content and bulk electrical conductivity of the medium.

Because the signal also depends on salinity, it is unknown whether TDRs will work effectively in salt. As salinity levels increase, the signal reflection from the ends of the rods in the TDR probe is lost because of conduction of the signal through the saline medium between the rods. There have been many attempts to solve this problem by coating the probe rods. However, coating the rods introduces some other problems (change in calibration, loss of sensitivity, wear of the coating affecting results, etc.). More investigation on this would be necessary before committing to this instrument for use in the SDDI field tests.

- **Heat Dissipation Probes** – A heat dissipation probe (HDP), or water matrix potential sensor, consists of a heating element and thermocouple placed in epoxy in a hypodermic needle, which is encased in a porous ceramic matrix. To calculate soil water matrix potential, a current excitation module applies a current to the heating element, and the thermocouple measures the temperature rise. The magnitude of the temperature rise varies according to the amount of water in the porous ceramic matrix, which changes as the surrounding salt wets and dries. These sensors are small and could be buried directly in the salt backfill or emplaced in the drift ribs.
- **Electrical Resistivity Tomography** – Electrical Resistivity Tomography (ERT) has been demonstrated to be an effective method to infer various hydraulic properties including water content and hydraulic conductivity from electrical measurements typically made by installing a number of electrodes along parallel paths. An electric current is induced into the test bed through two electrodes, and voltage is monitored through two adjacent electrodes. The process is repeated until current has been applied to all pairs of adjacent electrodes. The data from the electrodes is then processed to image the resistivity distribution. Based on the calibration curves (determined in the laboratory) of electrical resistivity as a function of water saturation, the correlation of water saturation level to electrical resistivity has about 1 percent precision in saturation levels below 40 percent.
- **Active Neutron Probe** – These instruments consist of a neutron source, generally a small isotopic source, and several neutron detectors spaced at various distances from the source. Usually there are both thermal and epithermal detectors. The active neutron probe measures the attenuation of the neutron flux as a function of the distance from the neutron source. The attenuation of the neutron flux is primarily a measure of hydrogen density, which is then used to infer the water concentration or formation porosity in a saturated formation. Access to the formation of interest is by means of a cased borehole. This technique is well documented in soils and other media but will need to be tested and calibrated in the lab prior to use in the salt backfill and the surrounding salt mass to ensure the technique can accurately measure such low moisture contents.



- **Ground Penetrating Radar** – Ground Penetrating Radar (GPR) technology is of particular interest for providing high-resolution subsurface images and specifically addressing water-related questions. GPR is based on the transmission and reception of VHF-UHF (30–3000 MHz) electromagnetic waves into the subsurface, whose propagation is determined by the electromagnetic properties of the medium and their spatial distribution. As the dielectric permittivity of water overwhelms the permittivity the solid or air phase, the presence of water in the soil principally governs GPR wave propagation. Therefore, GPR-derived dielectric permittivity is usually used as surrogate measure for water content. Access to the formation of interest is by means of a cross borehole configuration. The photo above shows field technicians conducting GPR measurements in an underground borehole.



**Photo 3-3: GPR Measurements**

- **Gas Sampling Ports** – Gas sampling is commonly used to obtain real-time samples in test beds using pre-emplaced tubing which could be installed directly in the salt backfill. Considerations that should be considered in the design include: 1) Sampling Rate: The faster the sampling, the larger the pressure differential, 2) Induced Vacuum: Dependent on variables such as moisture content as well as length and internal diameter of sampling line, 3) System Volume/Length of Tubing: System should be relatively small to minimize the volume of dead space that must be purged, 4) Effect of Connections and Fittings: Minimize connections and fittings so that there are no leaks, and 5) Effect of Porosity: Leakage along the tubing and induced fractures can impart high permeability to materials that would otherwise be low.
- **Brine Sampling Ports** – Using techniques similar to that described above for gas sampling, tubing could be emplacement directly in the salt backfill to enable sampling of brine during the test. If sufficient liquid is present at the heater surface, minimal sampling to determine brine composition and pH will be performed to assess whether, at the temperature regimes measured, there is formation of corrosive acid brine. This information would verify laboratory testing to determine heated brine acid formation.

### **Miscellaneous Measurements**

There will be measurements throughout the test location to monitor heat transfer properties, the characteristics of the inlet and outlet airstreams, and properties associated with the performance of the heating system. Measurements may also include diagnostics associated with the data collection system and other instrumentation systems and real-time video observation of the test drifts and test area.

- **Thermal Flux Meters** – Thermal flux meters are used to measure heat transfer and may be used in this test to monitor heat flow from the heater canisters into the rock mass or the salt backfill.

- **Power Meters** – Power meters will be used to measure the electric power consumed by the canister heaters.
- **Air Velocity Gages** – Environmental and ventilation gages will be installed in the test to evaluate thermal losses from the heated test drifts to the underground ventilation system. The environmental gages will likely consist of thermocouples that are emplaced inside the heated test drifts to measure the temperature of the air within the rooms. The ventilation gages will likely include thermocouples and air velocity sensors installed in SDDI access drifts in the vicinity of the heated test drifts. The ventilation thermocouples will measure air temperatures upstream and downstream from the heated test drifts, while the air velocity sensors will measure the velocity of the air moving through the access drifts by the mine ventilation system.
- **Gas/Air Pressure Transducers** – Gas and air pressure can be measured both from within the test drifts and in boreholes drilled near the test drifts or tubing installed in the crushed salt using pressure transducers and pressure lines.
- **Air Humidity Sensors/Chilled Mirror Hygrometers** – Whereas air humidity sensors (i.e., capacitive thin-film polymer sensors) are reliable, stable, accurate in most applications and commercially available, past experience using them in salt has resulted in early failures of the instrument and erroneous readings resulting from salt dust (sodium chloride) buildup on the sensor (e.g., a constant reading of ~75% RH).

Chilled mirror hygrometers (CMHs) will likely be a more robust and accurate measurement in these underground conditions for measuring the humidity of the drift air and the ventilated air entering and leaving the bulkheads. The CMH makes a direct measurement of the dew point temperature of a gas by allowing a sample of gas of unknown water vapor content to condense on an inert, chilled, mirror-polished metal surface. Thermoelectric modules are typically used to chill the surface. A beam of light, usually from a light-emitting diode (LED), is reflected from the surface into a photo-detector. There are a variety of other types of condensate detecting schemes, but light reflection from a mirrored surface is the classic method.

A typical CMH, in contrast to many other humidity sensors, can be made very inert, rendering it virtually indestructible and minimizing the need for recalibration. Drift air can be brought to the detector using sampling and pressure tubes run to various points of interest within the test bed.

- **Real-Time Remote Video** – Visual observation inside the test drift can be made through windows that will be installed in each bulkhead. In addition, medium to high-temperature video cameras will be mounted within the test drift and surrounding areas to provide real-time and remote observations of the test. Depending on the test temperatures, cameras with a variety of features can be installed including pan, tilt, zoom, and thermal imaging features.

### 3.4.5. Pre-Test Shakedown of Instrumentation

Gage selection and pre-test shakedown will be a critical component of a successful test program given the harsh conditions expected during the test, and are accounted for in schedule and cost as a precursor activity found in section 4. The selection process will be initiated by reviewing commercially available instrumentation in an effort to minimize design and field trials, and reviewing instrumentation previously used (and lessons learned) at WIPP and the salt thermal testing conducted in Germany. Some applications will likely require instruments to be designed or built by the SDDI field testing organization, including geophysical techniques, because suitable instrumentation from commercial sources may not be available. Gages will be sought that can operate in the harsh underground test environment of the SDDI test drifts where brine and heat can be detrimental to instrument performance. In addition, it will be required that the instruments be durable enough to provide data for the duration of the tests (up to several years). Prior to purchase, candidate instruments will be evaluated on the ability to meet anticipated operating conditions. Gage components that are determined to be susceptible to failure may be modified to minimize environmental degradation, and modifications will be passed on to the manufacturers through detailed specifications in purchase orders. Additional modifications to enhance gage operation may be made at the URL testing site by the SDDI test team personnel before gage installation. All instrumentation providing qualified data will be calibrated under the requirements of the SDDI quality assurance program prior to installation and post-test calibrated, as feasible.

As past thermal testing in salt has shown, the presence of brine can hinder the performance of the instrumentation systems and can also result in the degradation of equipment and instrumentation components. Field experience from previous WIPP studies quickly demonstrated that in the presence of brine and elevated temperatures, materials like stainless steel, aluminum, mild steel, Delrin plastic, etc., can corrode, resulting in the need to replace or reconfigure the equipment and instrumentation.

Certain fixes, such as anodizing an aluminum surface, can help prolong the materials. Additionally items under tension can experience stress corrosion cracking leading to component failure, and the combination of dissimilar metals can create galvanic reactions that can accentuate that process. As was learned in past WIPP thermal tests, because brine was present in quantities greater than expected and its deleterious effects proved to be very aggressive, active maintenance was essential and continuous throughout an experiment. Without active maintenance, instrumentation would have failed in periods as short as weeks. Gage maintenance will be an essential component of these planned SDDI demonstration tests.

The gages must be capable of measuring the full range of the predicted test drift response, or be adjustable as needed to allow measurements to continue over the full duration of the test. During the detailed test planning phase, calculations will be performed to provide estimates of test drift response for each of the tests. This modeling, together with the experience and technical judgment of the test designers, will enable the development of initial predictions of test room deformation, hydrologic responses, and temperature. Preliminary specifications for gage will therefore be based on the pretest response estimates for the test drifts (Munson, et al. 1997).

## SDDI Integration with Compaction Testing Underground at WIPP

The M&OC plans to conduct a test in the southern part of the WIPP underground to assess construction methods for compacted salt panel closures (Zimmerly and Carrasco 2012). Full-scale field testing of the emplacement and compaction of the run-of-mine salt will be performed in the WIPP underground facilities in drift W-30 between S-3310 and S-3650, south of bulkhead 506. Bulkhead 506 will be used to simulate a panel closure bulkhead. The drift is about 16 feet wide, about 12.5 feet high, and about 230 feet long. The field testing will allow for variations in emplacement and compaction of each of the zones and will allow for field adjustment. Run-of-mine salt will be built up and compacted to the crown of the drift, planned in 50 ft long sections. Emplacement and compaction processes and testing results will be documented and presented in an assessment results report developed by THE M&OC. This M&OC test activity is planned for the spring of 2012 and may run for several months. The final structure may be left in place for up to a year following the testing.

This M&OC compaction test activity may be leveraged to gain valuable insight into the techniques and challenges associated with emplacement, instrumentation, and post-test characterization of the run-of-mine backfill planned for SDDI Test Drift #2. In SDDI Test Drift #2, run-of-mine salt backfill is planned to be placed on top of the canisters to the crown of the drifts and compacted. Because the SDDI Test Drift is planned to contain a very similar backfill arrangement to the demonstration test planned for the compacted salt panel closures, important information that will aid SDDI test planning and field engineering can be obtained. Some of this important information that can be obtained includes:

- **Observation of settling that may occur between the compacted run-of-mine salt and the crown of the test drift.** It will be important to performance of the SDDI demonstration test that the emplaced and compacted salt backfill remain in contact with the ribs and crown of the test drift to force the airflow through the salt mass. If the salt settles and a gap is exposed near the crown, the ventilation will short-circuit the backfill and flow over the top and the test will not be analogous to the presumed emplacement drift conditions. Through direct observations by SDDI testing personnel, these early WIPP compaction testing activities are anticipated to provide confidence that the run-of-mine salt can be emplaced and compacted to the crown and remain in contact with the crown for the duration planned for the SDDI test period.
- **Demonstration of run-of-mine salt emplacement and compaction techniques.** It will be important for the WIPP constructor to practice run-of-mine emplacement techniques and anticipate issues that could arise when canister heaters and instrumentation are installed in the SDDI test drifts. These WIPP testing activities give both the WIPP engineers and the SDDI field engineers an opportunity to establish best practices for the emplacement of this backfill.
- **Demonstrate collection techniques and determine competency of core taken from the compacted salt.** Post-test forensics is an important aspect of the SDDI demonstration test. Samples of salt from the backfill will be required to integrate the post-test conditions. There are multiple ways to obtain these samples and dry coring is among them. It is uncertain if the cores will remain competent using standard coring techniques. Therefore, following the WIPP compaction testing, coring should

be conducted on the run-of-mine salt structure to determine the competency of the core and the collection process used to obtain it.

- **Determine the competency of cored holes in the compacted salt and demonstrate permeability testing techniques.** Similar to the previous information goal, once core is obtained from the run-of-mine salt structure, a smooth borehole is expected to remain that could be used for various in situ data gathering, such as permeability measurements. It would be valuable in the planning for SDDI if the quality of boreholes cored in the salt was ascertained. Certain measurements could be conducted in the boreholes as a proof-of-principle, for example, packer induced permeability measurements.

The activities described above in addition to others that may be conducted after the WIPP compaction tests are complete (such as instrumentation emplacement and survivability studies) would be of significant value in the planning and designing of the SDDI demonstration test and data gathering techniques. Because of the urgency to start these WIPP compaction test activities in W-30 (within the next couple months), and the relatively short period that the compacted salt may remain in the WIPP W-30 drift (approximately a year) due to WIPP operational considerations, there is some urgency to integrate the planning and implementation of these testing activities to take advantage of this unique opportunity.

## 4. PRELIMINARY COST AND SCHEDULE

---

This SDDI testing program is designed to obtain important information using a field demonstration of this in-drift disposal concept for DHLW. Even before the end of the heating phase of the SDDI field test, important real-time data will be gathered that will assist DOE-EM in assessing the viability of salt-based disposal of its wastes, and will inform the planning of the multi-alcove SDI field test. In parallel with test planning for the SDDI test, a complete evaluation will be performed on the existing field data collected in the legacy WIPP heater tests, to demonstrate a comprehensive consideration of all past tests and to bolster the safety case for HLW disposal in salt.

Figure 4-1 is an estimated schedule for conducting the SDDI field testing campaign. As shown in the Table 4-1, the estimated total cost of the SDDI test program will be approximately \$30 million over 5 years for the entire program (laboratory, modeling, field studies), of which, \$4.5M has been funded by DOE-NE in FY12. However, there is significant potential overlap between the SDDI program and the SDI program in the areas of management, underground technical support, construction, modeling, laboratory studies, and international collaboration. Depending on the phasing of the two field test programs (the more overlap between them, the more efficiencies can be achieved), there is approximately \$7M - \$10M of overlap between the SDI field test and the SDDI field test with the Ops Support, Data Collection System, Field Test Personnel, and the Management, QA and Safety functions. The other costs are discrete and specific to each test. Table 4-1 details the preliminary costs of the SDDI test program.

The schedule currently shows a test start in early 2015 if funding is made available. This schedule is driven primarily by excavation, test construction, and test implementation. These activities could be accelerated if desired by either adding additional crews (e.g., adding a second mechanical miner to the construction of the URL) or adding additional shifts for excavation and test installation. As noted in section 3.4.1, the current schedule is based on a one-year heating cycle of the two SDDI test drifts before a decision is made to either continue the heating or, if enough of the key phenomena such as the movement and fate of water have been observed and understood, allowing the drift to cool and conducting post-test forensics. Therefore, it is conceivable that the test could run for a couple years or more.

Table 4-1: Estimated Costs for the SDDI Field Test

SDDI Proposal Element	Comments	FY12	FY13	FY14	FY15	FY16/17	TOTALS
Management, Quality Assurance, and Safety	*Overlap with SDI Proposal		\$600	\$600	\$600	\$600	\$2,400
Evaluation of Existing Thermal Test Data		\$680					\$680
International Collaboration	*Overlap with SDI Proposal	\$130	\$150	\$150	\$150	\$150	\$730
F&OR and Test Planning Development		\$300	\$725				\$1,025
Lab Thermal, Mechanical, Hydrologic, and Chemical Studies	*Overlap with SDI Proposal	\$1,510	\$4,000	\$600	\$600	\$600	\$4,310
Predictive and Coupled Process Modeling	*Overlap with SDI Proposal	\$1,680	\$500	\$200	\$200	\$300	\$2,880
Field Test Proof of Principle - Installation and Operations	* Heating start FY15	\$700	\$6,150	\$6,350	\$1,650	\$4,050	\$18,900
<b>Instrumentation, Data Collection, and Testing</b>							
Test Drift Instrumentation Development and Procurement	* Two test drifts, five heater canisters each	\$175	\$1,000	\$900			\$2,075
Canister Heaters and Controllers Procurement			\$500	\$500			\$1,000
Data Acquisition System Procurement, Shakedown, and Calibration			\$350	\$300			\$650
Fiber Optic System Procurement and Shakedown for Data Transfer			\$300				\$300
Underground Camera System Procurement and Shakedown			\$200				\$200
Geophysical Assessment and Monitoring (e.g., vapor movement)		\$25	\$300	\$100	\$100	\$300	\$825
Instrumentation Shakedown, Calibration, and Installation			\$1,000	\$850			\$1,850
Underground Testing Personnel (e.g. data collection, active measurements)			\$500	\$1,300	\$1,100	\$1,100	\$4,000
Post-test Sample Collection Personnel						\$250	\$250
Investigate Salt Properties of Test Bed Location			\$200				\$200
Field Test Scientific Management (e.g., PIs)	* Test bed specific investigations at WIPP			\$300	\$300	\$300	\$900
<b>Construction and Ops Support</b>							
Mining - Access Drifts, Test Bed	* Labor is "in-kind" - Budget is for consumables	\$500	\$550				\$1,050
Coring - Core Rig Purchase + Instrument Coring	* Includes purchase or lease of new core rig & core crew		\$700	\$900			\$1,600
Ventilation Control			\$250	\$50			\$300
Dedicated Power Installation	* New line to test bed area		\$300	\$600			\$900
Safety Case and Work Control			\$50	\$50			\$100
Ops Support (e.g., access, utilities, heater installation)	* Over 50% infrastructure costs saved at WIPP		\$500	\$500	\$150	\$600	\$1,750
Test Forensics, Mine Back, Coring - Final Test Report						\$1,500	\$1,500
<b>TOTAL DISCRETE SDDI BUDGET BY YEAR</b>		<b>\$5,000</b>	<b>\$9,125</b>	<b>\$7,900</b>	<b>\$3,200</b>	<b>\$5,700</b>	<b>\$30,925</b>

\* FY12 Funded by DOE-NE at \$4,500K

Figure 4-1: Estimated Schedule for the SDDI Field Test

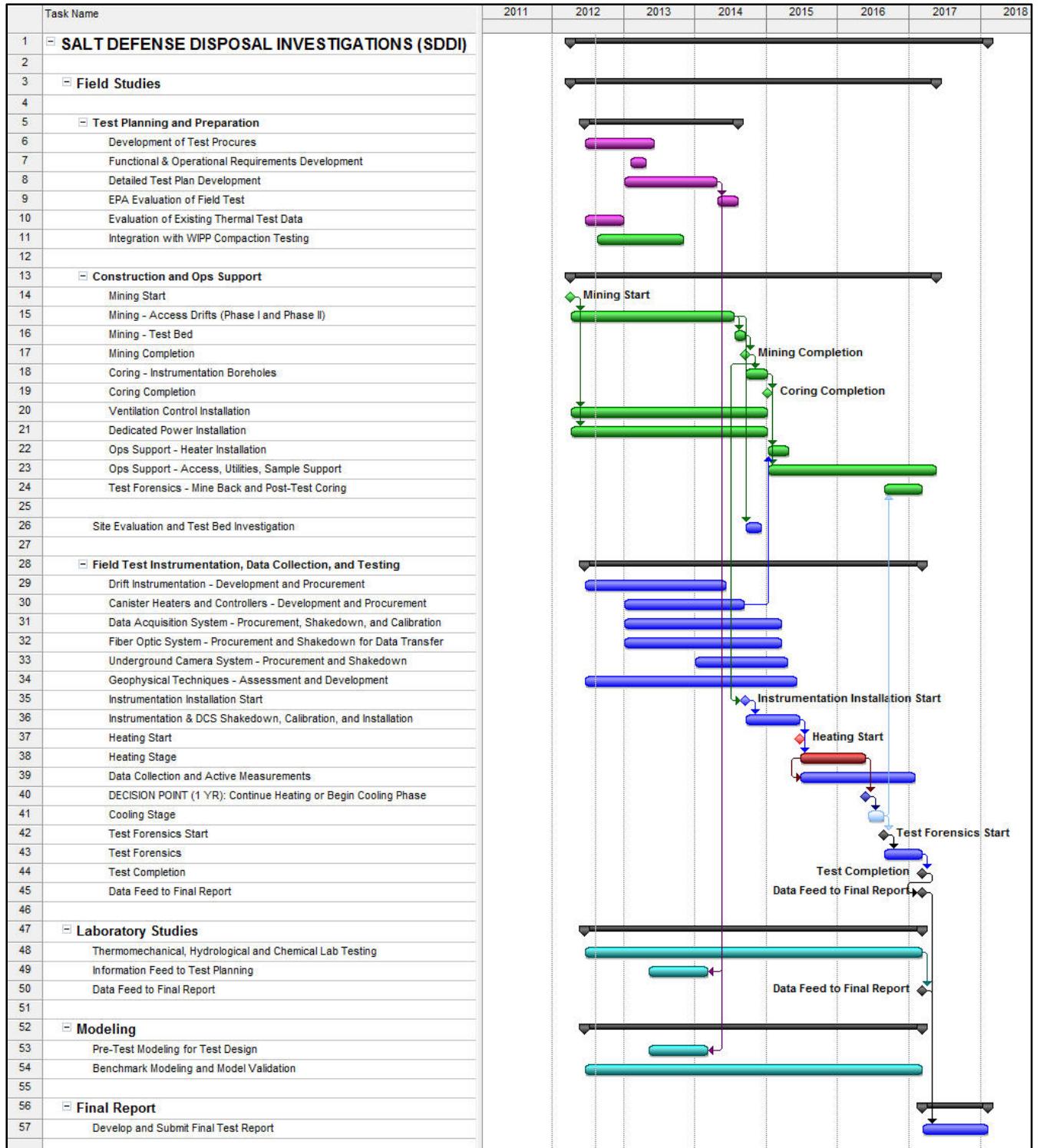



## 5. REFERENCES

---

- BRC, 2012. *Disposal Subcommittee Report to the Full Commission, Updated Report*. Blue Ribbon Commission on America's Nuclear Future. Washington, DC. January 2012.
- Carter, J.T., F.D. Hansen, R. Kehrman, and T.A. Hayes. 2011. *A Generic Salt Repository for Disposal of Waste from a Spent Nuclear Fuel Recycle Facility*. SRNL-RP-2011-00149. Savannah River: Savannah River National Laboratory.
- Carter, JT, P.O. Rodwell, B.A. Robinson, and R. Kehrman. 2012. *Defense Waste Salt Repository Study*. FCRD-UFD-2012-000113. Savannah River: Savannah River National Laboratory.
- DOE, 2011a. "Memorandum of Understanding Between The Department of Energy Office of Environmental Management and The Department of Energy Office of Nuclear Energy for Used Nuclear Fuel and Radioactive Waste Management and Processing Research and Development," April 29, 2011.
- DOE, 2011b. *Salt Disposal Investigations Quality Assurance Program Document*. DOE/CBFO-11-3465. U.S. DOE Carlsbad Field Office.
- DOE, 2011c. *A Management Proposal for Salt Disposal Investigations with a Field Scale Heater Test at WIPP*. DOE/CBFO-11-3470. June 2011. U.S. DOE Carlsbad Field Office.
- DOE OCRWM. 1998. *Drift Scale Test As-Built Report*. BAB000000-01717-5700-00003, Rev 1. July 1998. Las Vegas, NV.
- Droste, J. and T. Rothfuchs. *Long-term instrument performance – experience from a large scale test in rock salt*. 2003. Swets & Zeitlinger, Lisse, ISBN 90 5809 602 5.
- Hansen, F.D., and C.D. Leigh. 2011. *Salt Disposal of Heat-Generating Nuclear Waste*. SAND2011-0161. Albuquerque: Sandia National Laboratories.
- Hardin, E., J. Blink, H. Greenberg, M. Sutton, M. Fratoni, J. Carter, M. Dupont, and R. Howard. *Generic Repository Design Concepts and Thermal Analysis (FY11)*, SAND2011-6202. Albuquerque: Sandia National Laboratories. 2011.
- LANL, 2011. *Functional and Operational Requirements for the Salt Disposal Investigations Thermal Test at the Waste Isolation Pilot Plant*. LCO-SDI-001. July 2011. Los Alamos National Laboratory - Carlsbad Office.
- Letter, Senator Bingaman to Lyons and Huizenga. Dated January 12, 2012
- Letter, Mayor Janway to Senator Kirk. Dated November 22, 2011
- Letter, Governor Martinez to Secretary Chu. *Science Will Lead New Mexico's Role in Radioactive Waste Management*. Dated September, 1, 2011
- Munson, D.E., D.L. Hoag, D.A. Blankenship, W.F. DeYonge, D.M. Schiemeister, R.L. Jones, and G.T. Baird. 1997. *Instrumentation of the Thermal/Structural Interactions In Situ Tests at*

*the Waste Isolation Pilot Plant (WIPP)*. SAND87-2686. Albuquerque: Sandia National Laboratories.

National Academy of Sciences – National Research Council. *The Disposal of Radioactive Waste on Land*. Washington, D.C. September, 1957.

National Academy of Sciences – National Research Council. *One Step at a Time: The Staged Development of Geologic Repositories for High-Level Radioactive Waste*. 2003.

Notz, K.J.. *Characteristics of Potential Repository Wastes*, First Annual International High-Level Radioactive Waste Management Conference, Las Vegas, Nevada, CONF-900406-11. April 1990.

Robinson, B. A., N. Z. Elkins, and J. T. Carter. *Development of a U.S. Nuclear Waste Repository Research Program in Salt*. To appear in Nuclear Technology. 2012.

Shelfbine, H.C., *Brine Migration: A Summary Report*, Sandia National Laboratories Report SAND82-0152. 1982.

Tsang, C.F., O. Stephansson, L. Jing, and F. Kautsky, *DECOVALEX Project: from 1992 to 2007*, Environmental Geology, 57, 6, 1221-1237. 2008.

Used Fuel Disposition (UFD), *Used Fuel Disposition Campaign Disposal Research and Development Roadmap*, Document number FCR&D-USED-2011-000065 REV 0. March 2011.

Wald, M. L. Scientific American. *What Now for Nuclear Waste?* August 2009. Pages 46-53.

Zimmerly, B., and R. C. Carrasco. *Test Plan to Assess Construction Methods for Compacted Salt Panel Closures*. Washington TRU Solutions, LLC. January 27, 2012.

Zyvoloski, G.A., B.A. Robinson, Z.V. Dash, and L.L. Trease. 1997. *Summary of the models and methods for the FEHM application: A finite-element heat- and mass-transfer code*. Rep. LA-13307-MS. Los Alamos National Laboratory, Los Alamos, NM.

## **APPENDIX A - KEY CONTRIBUTORS TO THE SDDI PLAN**

---

Roger A. Nelson, U.S. Department of Energy – Carlsbad Field Office

Dr. Abraham E. Van Luik, U.S. Department of Energy – Carlsbad Field Office

Russell L. Patterson, U.S. Department of Energy – Carlsbad Field Office

Dr. Frank D. Hansen, Sandia National Laboratories

Michael D. Schuhen, Sandia National Laboratories

Dr. Ned Z. Elkins, Los Alamos National Laboratory

Clifford D. Stroud, Los Alamos National Laboratory

Dr. Bruce A. Robinson, Los Alamos National Laboratory

Dr. Bridget E. Ams, Los Alamos National Laboratory

Douglas J. Weaver, Los Alamos National Laboratory

John D. VandeKraats, Washington TRU Solutions

Rey C. Carrasco, Washington TRU Solutions

## APPENDIX B – EXAMPLES OF DOE SNF AND HLW CANISTERS

---

Figure B-1: Empty HLW Canister at the SRS



Figure B-2: Empty HLW Canister at Hanford

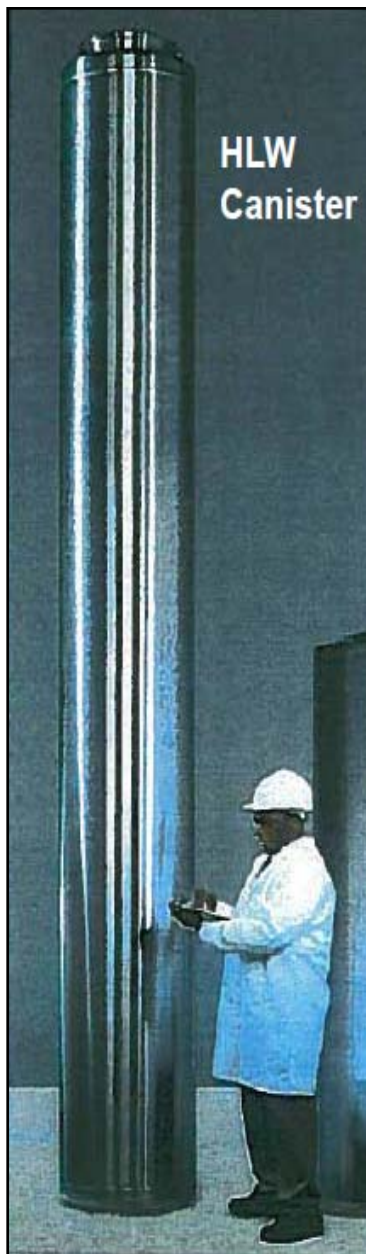

INTENTIONALLY LEFT BLANK