

US EPA ARCHIVE DOCUMENT

*The Waterfront, Allentown, PA
Conceptual Design Using Low Impact Development*

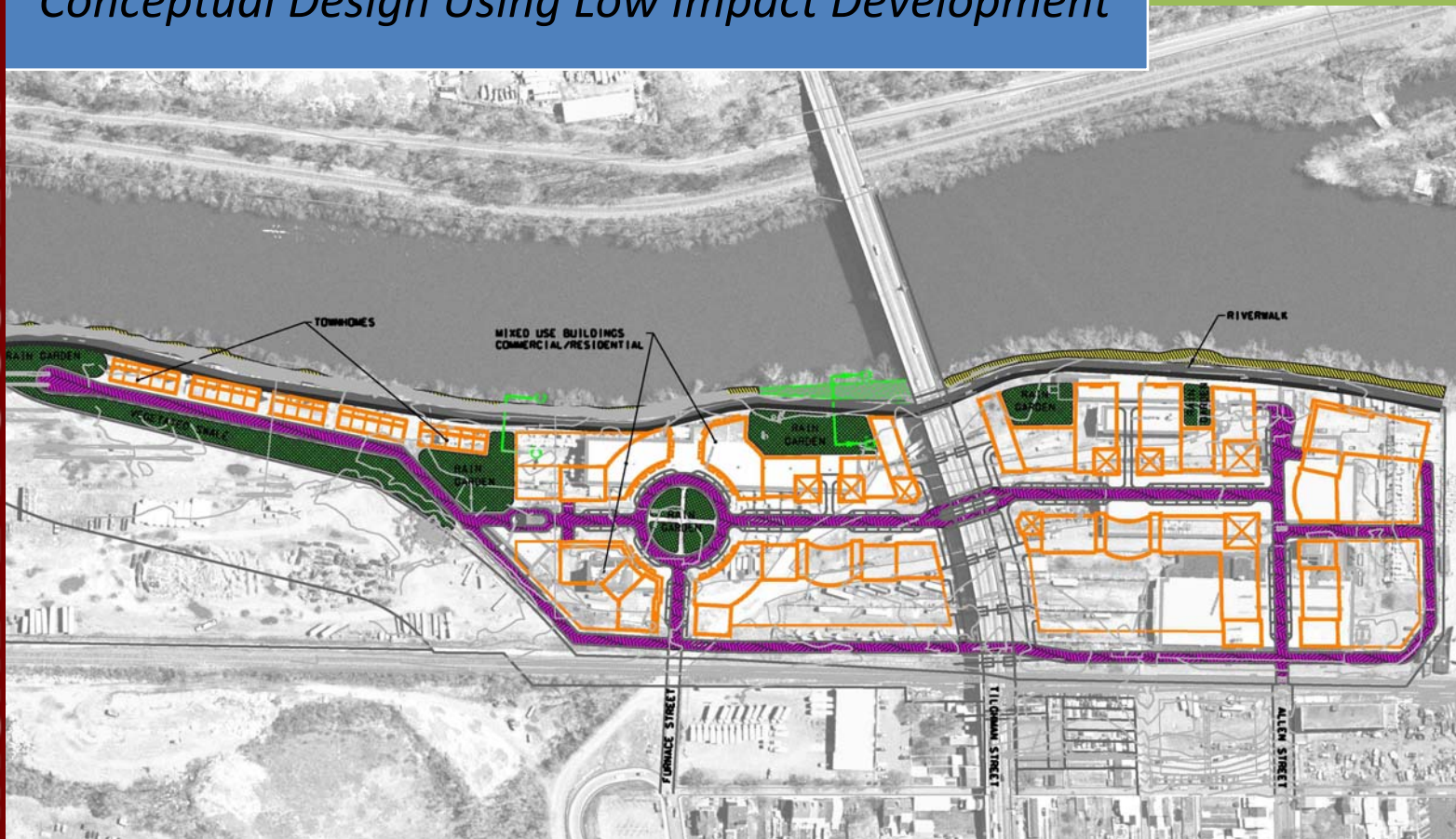

**TECHNICAL MEMORANDUM
BROWNFIELDS SUSTAINABILITY PILOT
THE WATERFRONT, ALLENTOWN, PA**

Prepared for:

U.S. Environmental Protection Agency
Office of Solid Waste and Emergency Response
Office of Brownfields and Land Revitalization
Washington, DC 20460

Prepared by:

Tetra Tech EM Inc.
1881 Campus Commons Dr.
Ste. 200
Reston, VA 20191

SRA International, Inc. (Contract No. EP-W-07-023)
3434 Washington Boulevard
Arlington, VA 22201

**TECHNICAL MEMORANDUM
BROWNFIELDS SUSTAINABILITY PILOT
THE WATERFRONT, ALLENTOWN, PA**

INTRODUCTION

The U.S. Environmental Protection Agency (EPA) Brownfields Program empowers states, communities, and other stakeholders to work together to prevent, assess, safely clean up, and sustainably reuse brownfields. Under this program, EPA's Brownfields Sustainability Pilots are providing technical assistance to support communities in achieving greener, more sustainable assessment, cleanup, and redevelopment at their brownfields projects. EPA selected The Waterfront in Allentown, PA, where a mixed-use redevelopment is planned, as a brownfields sustainability pilot. As part of this pilot, Tetra Tech EM Inc. (Tetra Tech), through a subcontract to SRA International, Inc., provided technical assistance to the Lehigh Valley Economic Development Corporation (LVEDC) and the site developer, Dunn Twigg Company LLC (Dunn Twigg), to integrate low impact development (LID) techniques and features for stormwater management into the site master plan. These LID stormwater management practices at the site will (1) help reduce or eliminate stormwater discharges and associated impacts from the development on the Lehigh River and (2) promote sustainable redevelopment opportunities elsewhere along the Lehigh River and in the City of Allentown.

This technical memorandum briefly describes the site and the master plan, indicates design constraints considered, specifies recommended LID stormwater techniques and features for sustainable redevelopment of the site, and offers other recommendations. The Waterfront master redevelopment plan prepared by Dunn Twigg is included as Attachment A. Conceptual design drawings prepared as part of this pilot are included in Attachment B. Federal Emergency Management Agency (FEMA) floodplain maps for the site are included in Attachment C.

SITE DESCRIPTION

The Waterfront redevelopment is located in a 26-acre Brownfields site on the west bank of the Lehigh River, about 0.5 mile south of Highway 22. The site is centrally located within a few miles of downtown Allentown and the Lehigh Valley International Airport. The site is currently occupied by multiple commercial and industrial businesses accessible by both paved and unpaved roadways and parking areas. Large, empty, aboveground storage tanks are present on the northern and southern portions of the site.

Public access to the riverfront is currently not available. The current site land use is industrial, involving iron and steel manufacturing and tank storage.

The site was built on fill material consisting primarily of steel slag and gravel. The fill material was observed to reach 6-8 feet below ground surface (bgs) along the western portion of the site and 10-14 feet bgs along the eastern portion of the site. Based on previous groundwater sampling, groundwater was found at 15 to 16 feet bgs. As part of a separate project for EPA Region 3, Tetra Tech sampled soil and groundwater at the site in July 2008 for metals and volatile organic compounds (VOC). Analytical sampling data for groundwater indicated VOCs exceeding the EPA Region 3 tap water screening level (SL) but below the Pennsylvania Department of Environmental Protection (PADEP) medium-specific concentrations (MSC) for non-residential groundwater, except for one groundwater sample in which the benzene concentration exceeded the PADEP MSC. Manganese and iron concentrations in groundwater were detected above their EPA SLs. Analyses of soil samples indicated that the metals lead, cadmium, and zinc were major soil contaminants at the site, with concentrations above their respective PADEP MSCs. Soil contamination possibly resulted from leachate of slag fill material at the site (Tetra Tech 2009).

Tetra Tech conducted a site visit in December 2008 to verify available topographic information regarding the riverbank, collect additional field observations, and meet with LVEDC, the developer, and local regulatory agencies. Based on field observations and topographic maps (Barry Isett & Associates 2008), the riverfront bank within the site boundaries is approximately 0.5 mile long with a typical slope of 1V:1H. A small area just north of the Tilghman Street Bridge has a flatter slope of approximately 1V:2H. At the time of the visit, the bank appeared stable, in large part due to the presence of large trees and other vegetation.

The proposed redevelopment master plan includes approximately 1,000,000 square feet (SF) of building area in an urban setting with residential, retail, and office space. In addition, the plan includes space for public parking, walking trails, and other features designed to increase appreciation for the historical, cultural, and environmental importance of the Lehigh River.

DESIGN CONSTRAINTS ON LID STORMWATER PRACTICES

Four major design constraints were considered during the identification and conceptual design of LID stormwater management practices for The Waterfront and these constraints should be considered during

subsequent detailed design and construction activities. These constraints include significant features of the master redevelopment plan for the site, soil and groundwater contamination, construction in the floodplain, and riverfront bank limitations. They are discussed below.

Master Redevelopment Plan

As previously discussed, Dunn Twigg prepared The Waterfront master redevelopment plan (see Attachment A). When developing LID stormwater management practices for the redevelopment, Tetra Tech considered the layout, building sizes, and other significant features of this master plan. In addition, the zoning requirements for riverfront property along the Lehigh River were considered (City of Allentown 2007). None of Tetra Tech's proposed LID stormwater practices will require significant modifications to the master redevelopment plan.

Soil and Groundwater Contamination

Based on available sampling results (Tetra Tech 2009), the groundwater at this site is contaminated with VOCs, manganese, and iron. Soil is contaminated with metals—primarily lead, cadmium, and zinc—and remediation may be required. Should site remediation be required, stormwater management would usually be limited to non-structural best management practices (BMP) that address impacts from earthwork and resulting migration of contaminated soil and groundwater. Site remediation alternatives may include removing contaminated material from the site, implementing isolation and capping, or mixing with clean soil at the site. Depending on a remedial alternative that may be required for the Waterfront, some LID stormwater management practices would not be appropriate for redevelopment. For example, LID stormwater management practices that encourage infiltration may be unsuitable if the contaminants have not been completely removed from the site or the residual soil contamination is soluble.

Floodplain Construction

Floodplains are lowland areas adjacent to rivers, lakes, or oceans that become inundated when extremely high water levels occur. Their value to the natural environment includes maintenance of water quality, provision of wildlife habitat, and flood water control. PADEP is the regulating agency responsible for floodplain activities throughout the State. Floodplains along the project riverfront were identified using the FEMA Flood Insurance Rate Maps (FIRM) found in Attachment C. As shown in the maps, a portion of the site, adjacent to the Lehigh River, is located in the 100 year floodplain zone. Title 25, Chapter 105 of the *Pennsylvania Code* requires a water obstruction or encroachment permit from PADEP for any development activity within a floodway or in floodplain areas (Pennsylvania Department of

Environmental Protection [PADEP] 2002b). The proposed redevelopment site will apparently fill in the floodplain; therefore, the design of any proposed stormwater structure should account for high water level conditions and the permitting issues associated with construction in the floodplain.

Riverfront Bank Limitations

The existing bank of the Lehigh River along the site is significantly narrow, approximately 15 feet wide (horizontal distance) from the edge of the water to the existing top of bank. The slope of the bank is also very steep, with slopes around 1V:1H for most of the 0.5 mile of shoreline within the site boundaries. Because of the narrow shoreline, the number of viable LID stormwater management practices is limited. Most LID practices include flatter slopes, so widening banks to achieve this would reduce the land available for development. Currently, the bank is apparently stable, in part due to the presence of large trees and other vegetation. Removal of non-native and other trees may be required as part of the development for aesthetic purposes and to create desirable views of the river. Tree removal or other restoration work in the shoreline banks could render the bank unstable. Any LID stormwater management practices proposed at the riverfront should be assessed with these stability constraints in mind.

RECOMMENDED LID STORMWATER MANAGEMENT PRACTICES

Considering the design constraints described above, several potential LID stormwater management practice were identified for The Waterfront site. These “green” practices are discussed below in the following three categories: (1) erosion and sediment control practices, (2) riverfront features, and (3) site redevelopment features. Erosion and sediment control practices could be applied throughout the site during construction activities. Potential locations for implementing riverfront and site redevelopment features at the site are shown in Attachment B on Sheet 2. The features proposed are concepts based on limited available information; therefore, these features and their locations would need alteration during detailed engineering and site design to determine their appropriateness and capacity for the redevelopment.

Erosion and Sediment Control Practices

During construction, site disturbance can impact the environment through soil erosion and sedimentation in nearby water bodies. In addition to minimizing areas of earth disturbance and soil compaction, the following green practices promise other benefits and should be considered during construction activities at the site:

- **Silt Fences:** Silt fences are appropriate at the top of the banks and should be installed perpendicular to the slope to retain sediments from construction. A detail for silt fences is shown in Appendix B on Sheet 3.
- **Turbidity Barriers:** Installing turbidity barriers in deep water bodies around the construction area will help confine sedimentation to smaller areas. A detail for turbidity barriers is shown in Appendix B on Sheet 3.
- **Erosion Control Blanket:** Erosion control blankets are applied on disturbed land before permanent vegetation is established. If the river shoreline at the site is disturbed during construction, erosion control blankets can be used on the slope to establish and reinforce vegetation. A detail for an erosion control blanket is shown in Appendix B on Sheet 3.
- **Sedimentation Basins:** During construction, runoff should be minimized by directing water outside disturbed areas into holding basins or vegetated depression areas.
- **Buffer Zone with Temporary Seeding:** Utilizing a buffer zone with temporary native seeding or covering exposed soil with erosion control blankets will help decrease soil erosion.
- **Existing Inlet Protection:** Currently, the site has a network of stormwater pipes that discharge directly to the Lehigh River. Providing protection to the inlets or catch basins, before the stormwater system is removed from the site, will help reduce sediment loss during construction activities. Inlet protection products act as sediment barriers that filter runoff before it enters the stormwater system. Typical inlet protection products include catch basin sediment bags, curve inlet and ditch pavement filters, and grate inlet boxes.

The erosion and sediment control features proposed during construction of The Waterfront should comply with the requirements of Chapter 102 of *Pennsylvania Code*, Title 25, Environmental Protection: “Erosion and Sediment Control” (PADEP 2002a).

Riverfront Features

The riverfront is one of the major assets of The Waterfront redevelopment. Creating additional green space along the riverwalk and enhancing the existing banks will create opportunities for recreation and add value to the community. LID practices can be designed and implemented in the riverfront to preserve, enhance, and protect the riverfront, including the following:

- **Soil Bioengineering Techniques to Naturally Reinforce Bank Slopes:** Currently, the riverfront bank is apparently stabilized in part due to the presence of large trees and other vegetation. Removal of non-native or other undesirable trees and plants may be required as part of the development for aesthetic purposes and to create desirable views of the river. Undesirable plants are usually removed by mechanical methods (herbicides, track-mounted equipment for brush removal), but in some sensitive or difficult areas, hand clearing with portable tools might be the only appropriate method. However, tree removal or other restoration work on the riverfront could cause instability of the bank. Soil bioengineering is the use of plant material, living or dead, to alleviate environmental bank instability problems such as shallow rapid landslides, and eroding slopes and streambanks. In soil bioengineering systems, plants are an important structural

component, as well as an aesthetic component. This approach to slope stabilization requires a true partnership between engineering geologists, maintenance personnel, civil engineers, and landscape architects. Examples of soil bioengineering systems are numerous, and selection of the appropriate system is critical to successful restoration. Soil bioengineering often mimics nature by using locally available materials and a minimum of heavy equipment. Plants that can resist the mechanical stresses of erosion, floods, and landslides—while developing strong, stabilizing root systems—are best suited for soil bioengineering applications. Examples of riparian plants suitable for soil bioengineering work on steep slopes similar to the slopes at The Waterfront site include willow, dogwood, cottonwood, big leaf maple, spruce, cedar, aspen, and alder (U.S. Department of Agriculture [USDA] 2000). Alternatively, it might be possible to salvage similar native species from a nearby area, if available. A single species may serve the primary structural requirement of the vegetation in a soil bioengineered system. However, a mixture of native species with varying, but complementary, characteristics is preferable.

Two soil bioengineering techniques appropriate for The Waterfront site are brush layering and live fascines. Sheet 4 of the conceptual drawings in Appendix B includes details for these techniques. Brush layering consists of inserting live, cut branches or brush between successive lifts or layers of compacted soil. This process works best in conjunction with construction of a fill slope. The tips of the branches protrude just beyond the face of the fill where they intercept rainfall, slow runoff, and filter sediment out of the slope runoff. The stems of the branches extend back into the slope in much the same manner as conventional, inert reinforcements. However, unlike conventional reinforcements such as geogrids, geotextiles and tieback anchors, the brushlayers root along their lengths and also act as horizontal slope drains. Horizontal drains are created by the void spaces between the brushlayer roots and soil. These natural drains intercept groundwater in the slope and reduce slope stability problems from subsurface seepage. This drainage function is very important and can greatly improve mass stability by redirecting the water flow direction. Brushlayers alone will suffice to stabilize a slope where the main problem is surficial erosion or shallow face sliding; sandy slopes with little or no cohesion fall into this category. Deeper seated sliding tends to occur in embankment slopes composed of more fine-grained, cohesive soils; this situation may require use of biotechnical stabilization. For The Waterfront redevelopment, the west part of the site, adjacent to the Lehigh River, appears to be located below the 100-year baseflood elevation (see Attachment C). Since the site and the bank slope may need to be filled to an elevation above the baseflood elevation, the brush layering technique may be an appropriate reinforcement technique.

Live fascines are long bundles of branch cuttings made from living woody plant material bound together into sausage-like structures. The bundles are laid across terraces and spliced together at each end. Terraces are cuts in the slope that break-up the slope length to encourage native plant seed collection and growth. Vegetation is planted between terraces. This immediately reduces surface erosion in steep and rocky slopes where digging is difficult. The cut branches are expected to grow, producing roots for additional soil reinforcement and top growth for surface protection. The live fascines are usually installed from the normal water elevation upward along the face of an eroded streambank in order to protect the bank toe and bank face. They are also useful over the crown of the bank slope to improve erosion control, infiltration, and other riparian zone functions.

- **Biotechnical Stabilization (Living Wall Systems):** Biotechnical stabilization is similar to soil bioengineering except that it integrates or combines the use of living vegetation and inert structural components. Live cuttings and stems are purposely imbedded and arranged in the ground where they serve as soil reinforcements, horizontal drains, barriers to earth movement, and hydraulic pumps or wicks. Live plants and plant parts are used in conjunction with

geotextiles or geogrids. The live cut stems and branches provide immediate reinforcement; secondary stabilization occurs as a result of adventitious rooting that occurs along the length of buried stems. The use of tensile inclusions (geotextile or grids) makes it possible to repair slope failures or to construct steepened slopes. Biotechnical stabilization is appropriate for deeper seated sliding that occurs in embankment slopes composed of more fine-grained, cohesive soils. These biotechnical stabilization techniques are also called vegetated geotextiles or living walls systems (Gray and Sotir 1995). A detail of geogrids with brushlayering is shown in Appendix B, Sheet 4.

- **Naturalized Detention Areas with Wetland Vegetation:** Naturalized detention areas with wetland vegetation emulate natural wetland systems by utilizing native plants along the water's edge and on side slopes. The function of these areas is to provide flood protection, remove pollutants, and create wildlife habitat. Naturalized detention requires wider areas of riverfront with flatter slopes. Given the current shoreline conditions at The Waterfront, the area near the river just north of the Tilghman Bridge could be used to create a naturalized detention area with wetland vegetation. This area is appropriate because it is the only area with flatter slopes along the riverfront site. The design of this naturalized detention area must comply with floodplain construction regulations. Naturalized detention areas could be created in other areas along the riverfront, but would require regrading the shoreline to create wider areas with flatter slopes. However, this would reduce the area of land on the site that could be redeveloped. Details and location of the recommended naturalized area is shown in the conceptual drawings in Appendix B on Sheet 3.
- **Infiltration Trenches and Filter Strips:** Infiltration trenches are linear stormwater BMPs consisting of a continuously perforated pipe at a minimum slope in a stone-filled trench. An infiltration trench can be part of a stormwater conveyance system and is designed so that runoff from large storm events is conveyed through the pipe with some volume reduction. During small storm events, volume reduction may be significant, with little or no discharge from the trench. All infiltration trenches are designed with a positive overflow. Infiltration trenches are more effective and have a longer life when they include some form of pretreatment such as vegetated filter strips (EPA 1999). Infiltration trenches in combination with filter strips can be used at the Waterfront site along the riverwalk to catch stormwater from impervious areas located to the east of the riverwalk and prevent its discharge to the river, as shown in the conceptual drawings. Sheet 3 in Appendix B shows a typical detail of an infiltration trench.
- **Riverwalk with Pervious Pavement:** The use of pervious pavement for the riverwalk will help reduce runoff and attenuate flows during small storm events. Pervious pavement consists of a pervious surface course underlain by a stone bed of uniformly graded and clean aggregate with a void space of at least 40%. The pervious pavement may consist of pervious asphalt, pervious concrete, or pervious pavement units (pavers). Stormwater draining through the pervious surface is temporarily held in the voids of the stone bed and then slowly drains into the underlying, uncompacted soil mantle. The stone bed can be designed with an overflow control structure to control peak rates during large storm events and to drain soils with low permeability (PADEP 2006). Details of pervious pavement are included in Appendix B on Sheet 6. For the riverwalk, pervious concrete pavement is appropriate as it provides a smooth surface for bikers and rollerbladers.

Site Redevelopment Features

Several green practices could be implemented throughout The Waterfront redevelopment site. The main objectives of implementing green practices for redevelopment are to (1) minimize creation of impervious area, (2) maximize stormwater infiltration (if possible), and (3) reduce stormwater from the site by capturing runoff at the source and dispersing it to a number of BMPs located throughout the site (rather than conveying and concentrating runoff to just a few locations). Green practices recommended for the site redevelopment include:

- **Pervious Pavement:** Pervious pavement can be used at The Waterfront site on local streets and sidewalks. As previously discussed, stormwater draining through the pervious surface is temporarily held in the voids of the stone bed and then slowly drains into the underlying, uncompacted soil. The stone bed can be designed with an overflow control structure to control peak rates during large storm events and to connect the pervious pavement to a bioretention area (PADEP 2006). Sheet 2 of the conceptual design drawings, on Appendix B, shows potential locations of pervious pavement at the Waterfront site. Details of different types of pervious pavement are shown on Sheet 6 in Appendix B. The pervious pavement may consist of pervious asphalt, pervious concrete, or pervious pavement units (pavers).
- **Bioretention Areas (Rain Gardens and Vegetated Swales):** Bioretention is a practice to manage and treat stormwater runoff by using a conditioned planting soil bed and planting materials to filter runoff stored within a shallow depression. Bioretention provides good options for water quality BMPs on all sites, including brownfield sites. Bio-retention coupled with infiltration should be considered on brownfield sites where all soil contaminants have been removed during remediation, or where only non-soluble contaminants remain. On Brownfields sites where soluble contaminants are still present in the soil, bio-retention BMPs should be designed so that all water passing through the planting soil is directed to an overflow and not permitted to infiltrate (PADEP 2006). Bioretention areas considered for The Waterfront site include rain gardens and vegetated swales. Details of these BMPs are included on the conceptual design drawings in Appendix B, Sheet 6.
- **Green Roofs:** Green roofs are vegetated roofs that consist of shallow soil thickness (usually 6 inches) and an engineered media with waterproof system used to retain much of the rainwater that falls on the roof. This BMP is very effective in areas where subsurface systems are not feasible or there is need to reduce stormwater runoff. They also serve other purposes such as energy savings within buildings through natural cooling and extension of roof longevity (PADEP 2006). Green roofs could be installed on flat, large buildings planned for The Waterfront to minimize runoff from impervious roof surfaces. The structural design of the buildings that will hold the green roofs should account for the additional weight of the soil material. Green roofs can have extensive or intensive types of vegetation. Extensive vegetation plants such as sedums and prairie flowers can tolerate almost any kind of weather conditions, require soil depths of 6 inches or less, and abide low maintenance with no irrigation. Intensive vegetation plants include hardy perennials, native flowers, and shrubs; this vegetation type roof is heavier, with soil depths of 6-24 inches, and requires higher maintenance. If intensive vegetation is used, the green roof acts similar to a rain garden and can provide aesthetic and architectural value as well.

- **Cisterns and Rain Barrels:** Cisterns and rain barrels are rain catchment and storage units that can be placed in corners of structured parking lots, inside buildings, on the outside walls of buildings, underground, in adjacent alleys, alongside elevator shafts, and at other locations deemed feasible by the designer. The shape, size, and location of this BMP require very little land area. Water collected this way can be re-used for non-potable applications such as fire suppression, drip irrigation, lawn sprinkling, building cooling, toilet flushing, and recreational water (PADEP 2006). Cisterns, supplemented with potable water, could also feed small fountains. Existing tanks at the site could be refurbished for use as cisterns.

RECOMMENDED SUPPORT STUDIES AND OTHER ACTIVITIES

To facilitate the selection and detailed design and integration of LID techniques, and before incorporating these features for stormwater management in The Waterfront site master plan, the following additional support studies and other activities are recommended:

- **Shoreline Tree Survey:** A shoreline tree survey to inventory tree species and sizes should be conducted to identify (1) non-native tree species for removal and (2) native tree species that should be left in place for shoreline stability or aesthetic purposes. As discussed previously, in areas where tree or other vegetation removal is determined to be necessary for redevelopment, soil bioengineering techniques to naturally reinforce bank slopes or biotechnical stabilization should be considered to stabilize slopes where necessary.
- **Geotechnical Investigation for Soil Permeability:** A geotechnical soil survey should be conducted to determine the soil permeability where the LID stormwater features that encourage infiltration will be implemented. Design and effectiveness of LID stormwater features depend significantly on infiltration capacity of the soils. If soil permeability is found to be low, underdrains should be added to the LID design.
- **Geotechnical Investigation for Soil Stability:** An analysis of the soil stability of the Lehigh River bank within the project site should be conducted to identify the potential soil problems that could arise when the slopes are altered or vegetation is removed. Also, it is important to determine the soil stability after raising the bank with fill to levels above the baseflood elevation.

REFERENCES

- Barry Isett & Associates, Inc. 2008. ALTA/ACSM Survey Plan for LSS Realty Corporation Inc., City of Allentown. Topographic Survey for The Waterfront Site.
- City of Allentown. 2007. Draft Overlay Zoning District for Riverfront Property Along the Lehigh River. City of Allentown, Lehigh County, PA.
- U.S. Environmental Protection Agency (EPA). 1999. Low-Impact Development Design Strategies – An Integrated Design Approach. Prepared by Prince George’s County, Maryland, Department of Environmental Resources. Largo, MD. June.
- Gray, Donald and Robbin Sotir. 1995. Biotechnical Stabilization of Steepened Slopes. Prepared for the Transportation Research Board 746th Annual Meeting. Washington, D.C. January 22-28.
- PADEP. 2002a. *Pennsylvania Code*, Title 25. Environmental Protection, Chapter 102. Erosion and Sediment Control. Harrisburg, PA. December 28.
- PADEP. 2002b. *Pennsylvania Code*, Title 25. Environmental Protection, Chapter 105. Dam Safety and Waterway Management. Harrisburg, PA. December.
- PADEP. 2006. *Pennsylvania Stormwater Best Management Practices Manual*. December 30.
- Tetra Tech EM Inc. (Tetra Tech). 2009. Draft Trip Report for the Former Lehigh Structural Steel Site Groundwater and Soil Investigation. Prepared for EPA Region 3, EPA contract N0. EP-S3-05-02. Allentown, PA. March 20.
- United States Department of Agriculture (USDA). 2000. *Soil Bioengineering – An Alternative for Roadside Management, A Practical Guide*. By Lisa Lewis, USDA Forest Service. San Dimas, CA. September.

ATTACHMENT A

SITE REDEVELOPMENT MASTER PLAN

THE WATERFRONT
CONCEPTUAL MASTER PLAN



Exhibit A

ATTACHMENT B

CONCEPTUAL DRAWINGS

THE WATERFRONT ALLENTOWN, PA

Conceptual Design Drawings for LID Techniques Brownfields Sustainability Pilot Project

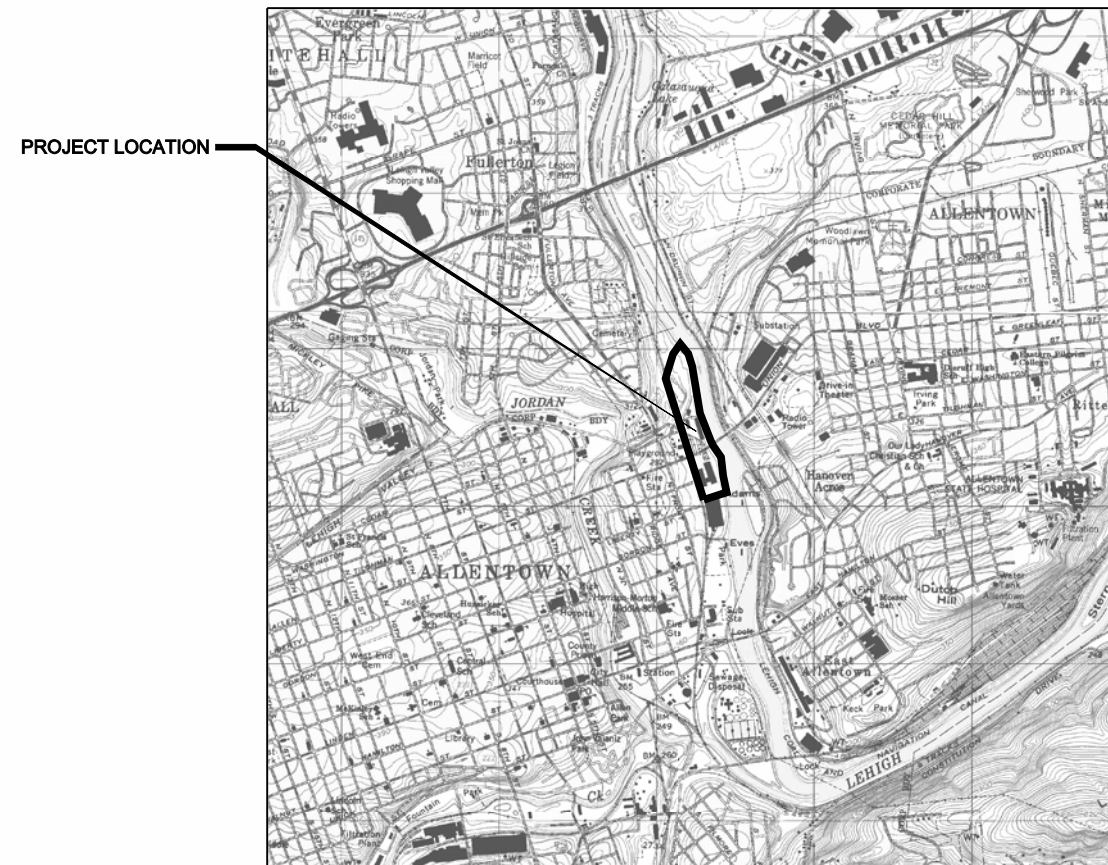

MARK	DATE	DESCRIPTION	BY
			DGS

Client: EPA
 Project Location: ALLENTOWN, PA
**THE WATERFRONT
 BROWNFIELDS SUSTAINABILITY
 PILOT PROJECT**
 Project No.: 103DG1392-1806.02
 Designed By: TXH
 Drawn By: KFV
 Checked By:

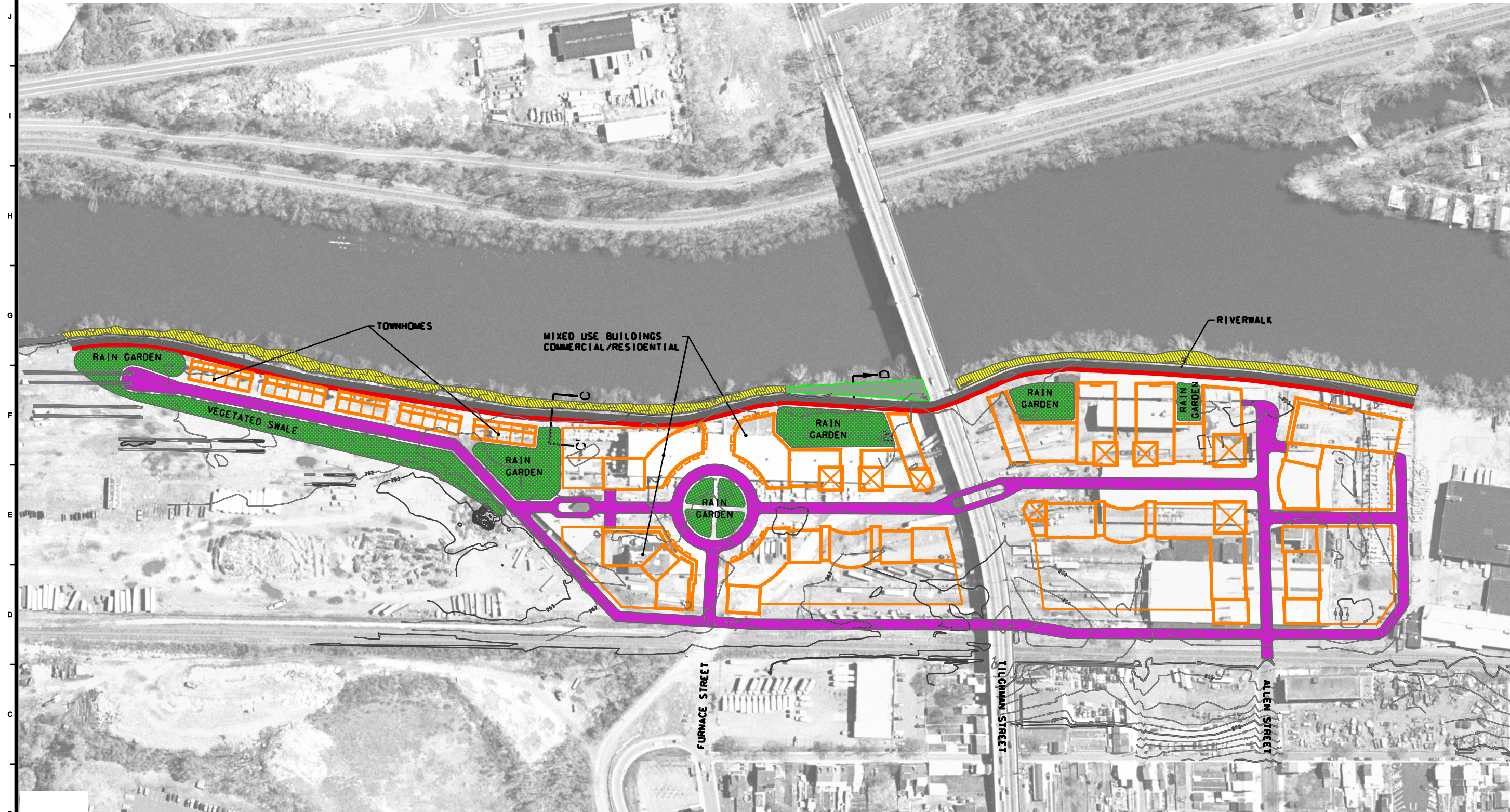

LEGEND

- BUILDINGS
- RIVERWALK (PERVIOUS CONCRETE PAVEMENT)
- SOIL BIOENGINEERING
- BIORETENTION AREAS
- FILTER STRIPS / INFILTRATION TRENCH
- PERVIOUS PAVEMENT (CONCRETE, ASPHALT, PAVERS)
- NATURAL DETENTION AREA / WETLAND VEGETATION

OTHER LID TECHNIQUES NOT SHOWN

- GREEN ROOFS
- CISTERNS (UNDERGROUND AND ABOVE GROUND)
- RAIN BARRELS

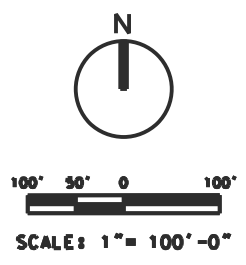

TETRA TECH

Tt

1 SOUTH WACKER DRIVE
CHICAGO, IL 60606
PHONE: 312.201.7700 FAX: 312.201.0081

SITE PLAN
STORM WATER LID

BY	DATE	DESCRIPTION
DGS		

Client: EPA
Project Location: ALLENTOWN, PA

**THE WATERFRONT
BROWNFIELDS SUSTAINABILITY
PILOT PROJECT**

Project No.: 103DG1382-1806.02
Designed By: TXH
Drawn By: KPV
Checked By:

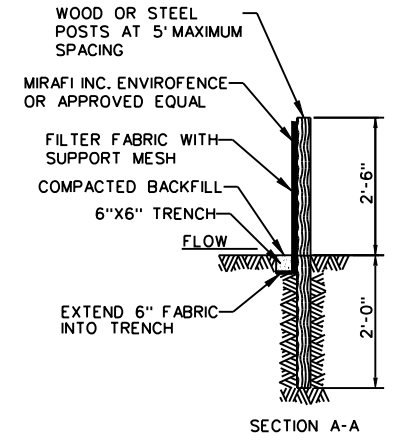

1. FILTER BARRIERS SHALL BE PLACED WHERE SHOWN ON THE PLANS AND WHERE INDICATED BY THE ENGINEER, PRIOR TO ANY GRADING WORK IN THE AREA TO BE PROTECTED.
 2. SEDIMENT TRAPPED BY THE FENCE SHALL BE REMOVED (AND PROPERLY DISPOSED OF) WHENEVER ACCUMULATION OCCURS.
 3. BARRIERS SHALL BE MAINTAINED IN PLACE UNTIL THE UP SLOPE AREA HAS BEEN STABILIZED AND REMOVAL IS AUTHORIZED BY THE ENGINEER.
 4. FILTER FABRIC SHALL MEET THE REQUIREMENTS OF ILLINOIS URBAN MANUAL MATERIAL SPECIFICATION 592 GEOTEXTILE TABLE 1 OR 2, CLASS 1
 5. FENCE POST SHALL HAVE A MINIMUM CROSS SECTIONAL AREA OF 3.0 SQ. IN.
- SILT FENCE**
EROSION AND SEDIMENT CONTROL

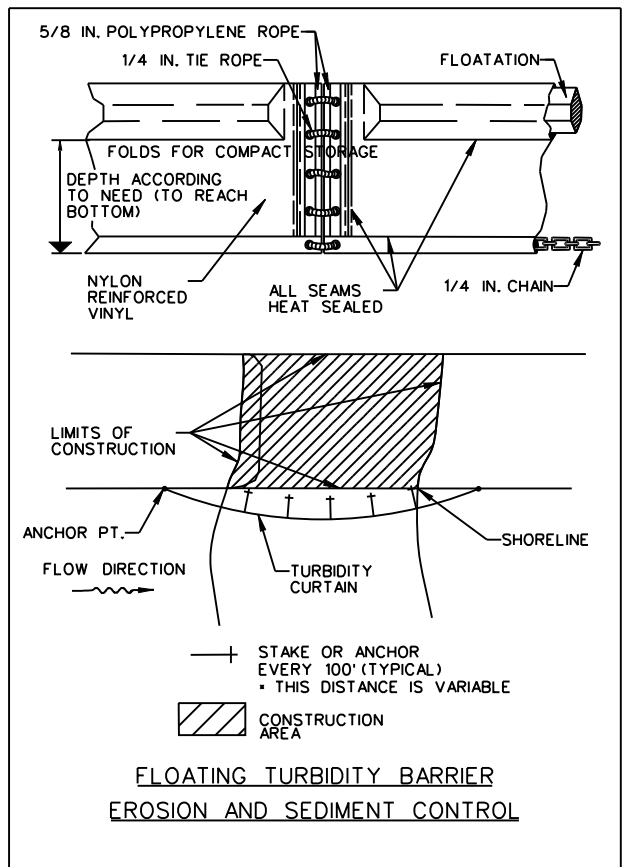

- NOTES:
1. ANCHOR, OVERLAP & STAPLE AS PER MANUFACTURER SPECIFICATIONS
 2. 1' SPACING ON STAPLES IN ANCHORING TRENCH

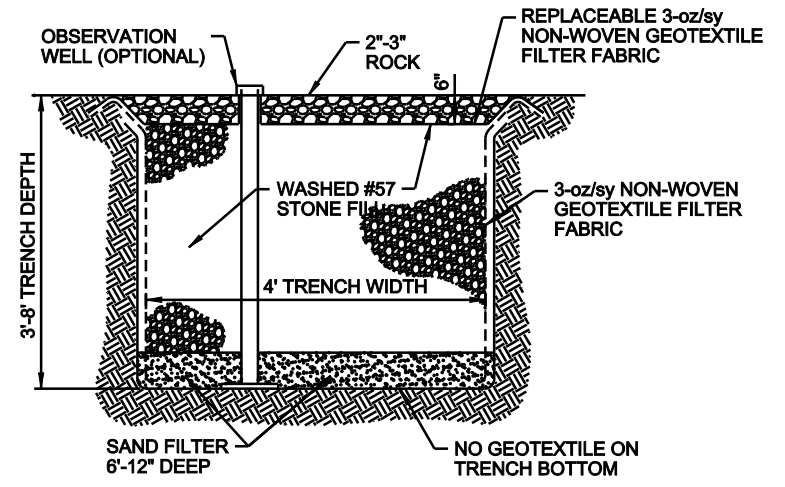
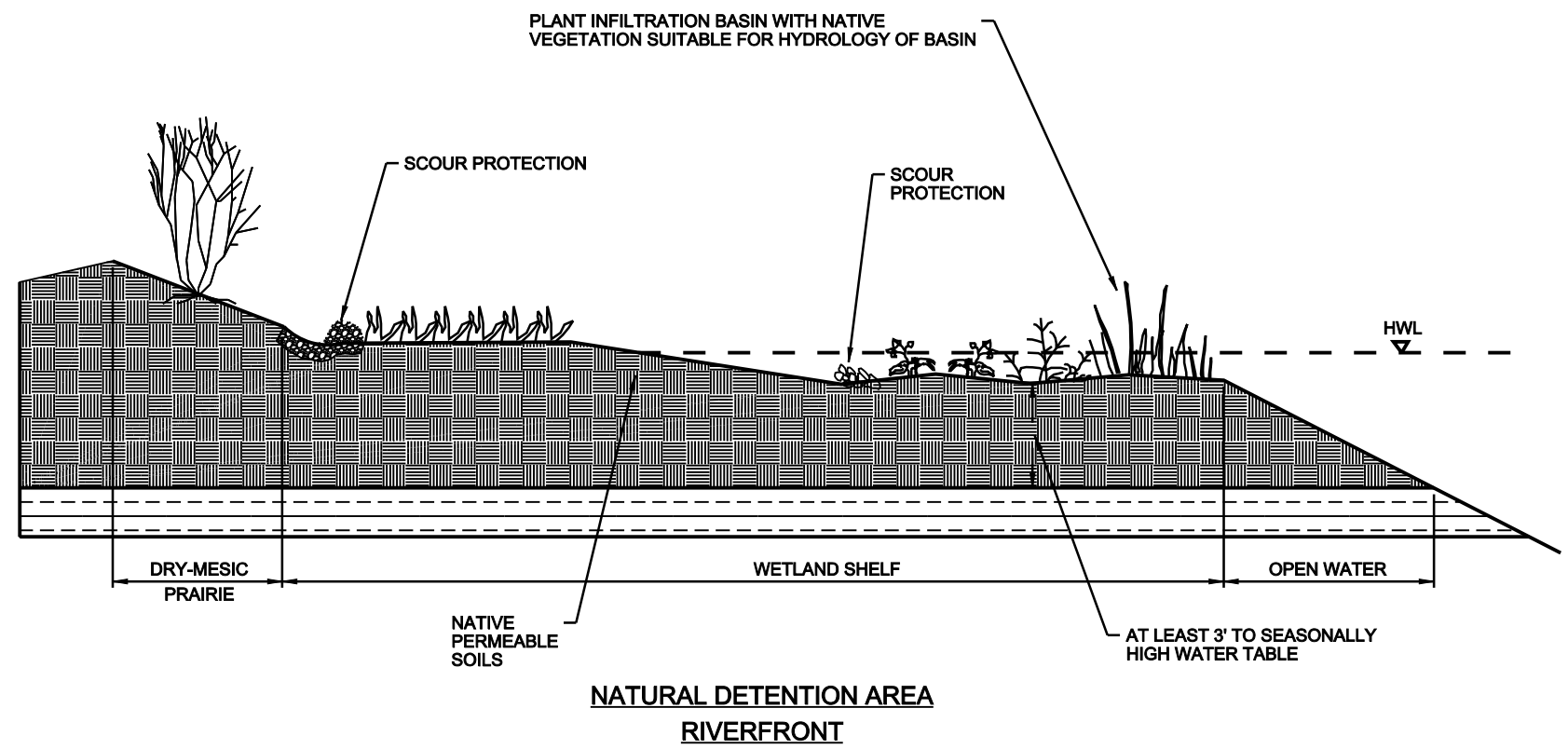
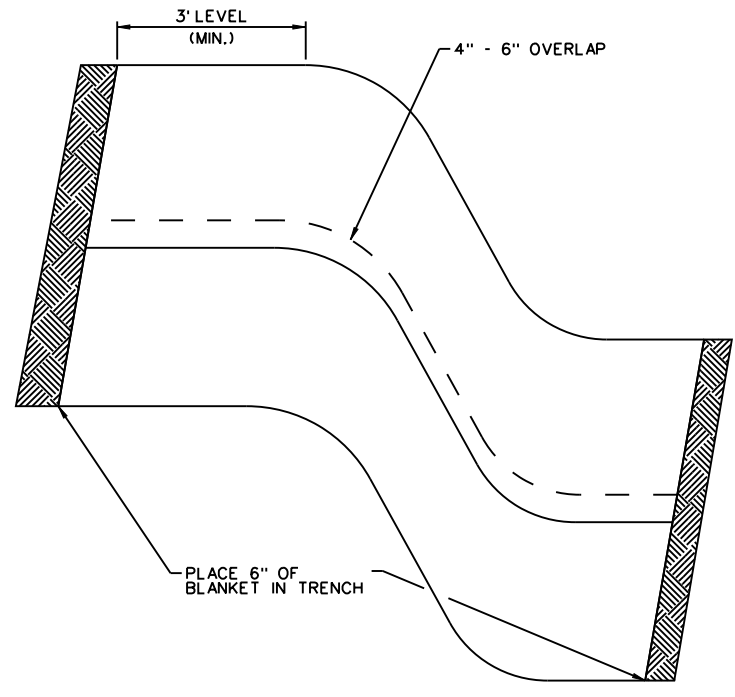

BY	DATE	DESCRIPTION
DGS		

Client: EPA	Project Location: ALLENTOWN, PA.
THE WATERFRONT BROWNFIELDS SUSTAINABILITY PILOT PROJECT	
Project No.: 103DG1382-1806.02	Designed By: TXH
	Drawn By: KPV
	Checked By:

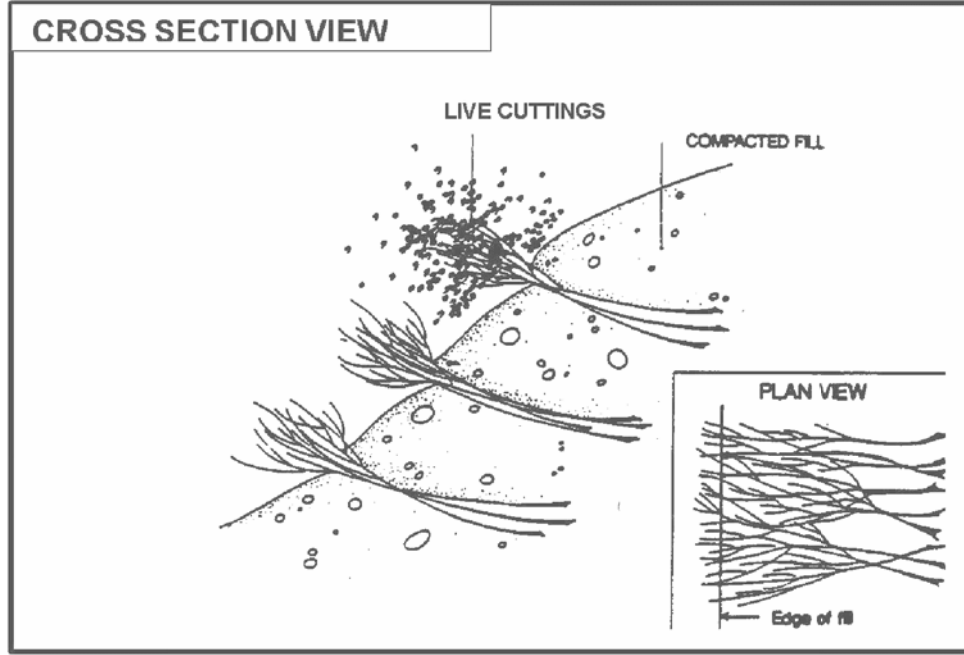

**SOIL BIOENGINEERING - BRUSHLAYER
RIVERFRONT**

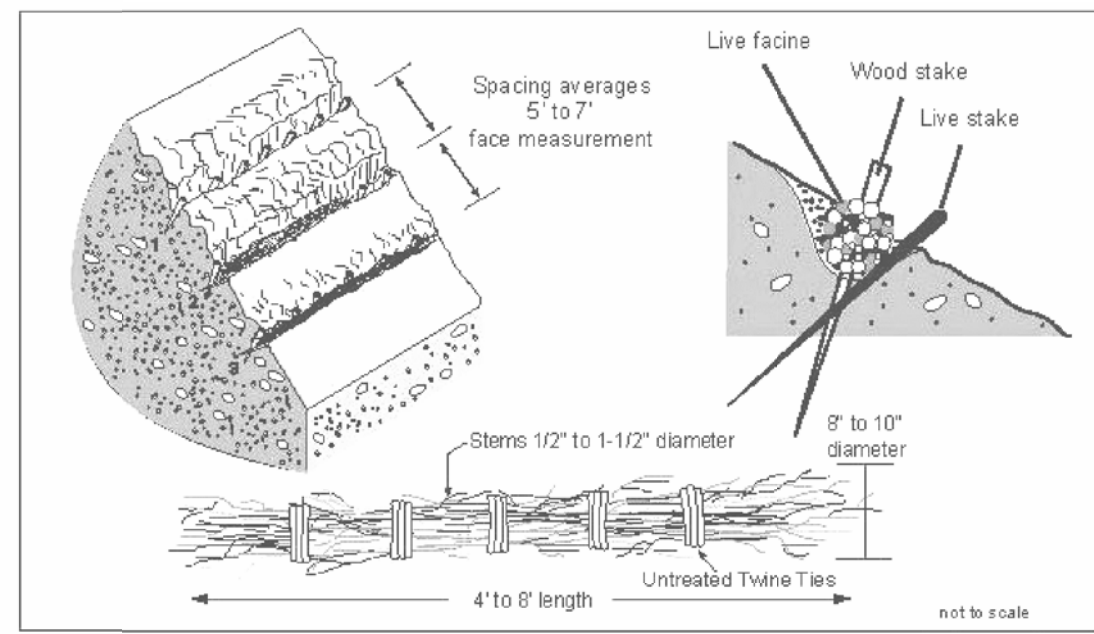

**SOIL BIOENGINEERING - LIVE FASCINES
RIVERFRONT**

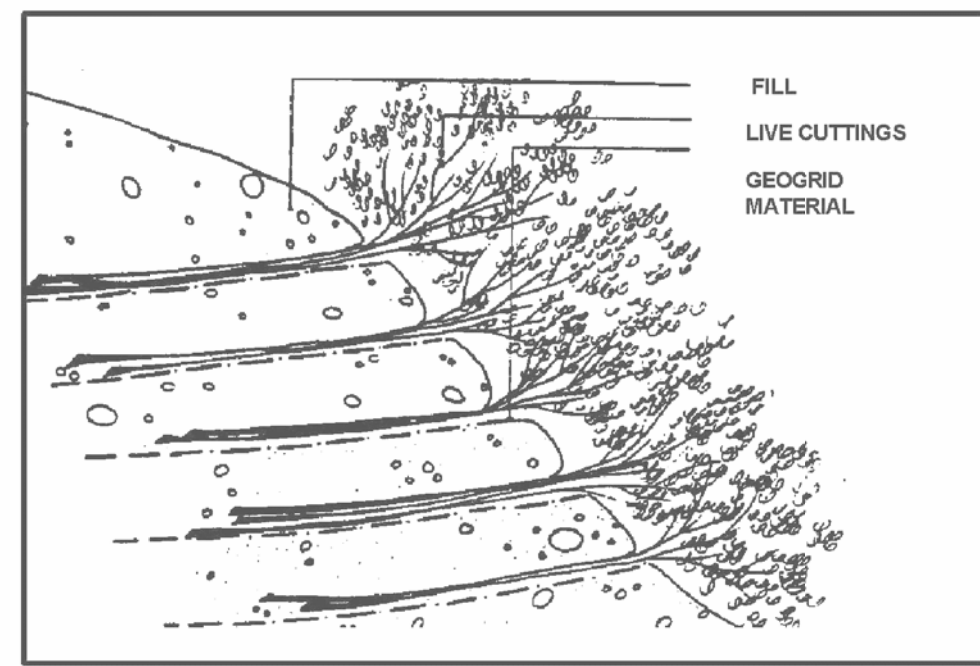

**BIOTECHNICAL STABILIZATION - GEOGRIDS WITH BRUSHLAYER
RIVERFRONT**

MARK	DATE	DESCRIPTION
BY	DGS	

Client: EPA
Project Location: ALLENTOWN, PA.

**THE WATERFRONT
BROWNFIELDS SUSTAINABILITY
PILOT PROJECT**

Project No.: 103DG1382-1806.02
Designed By: TXH
Drawn By: KFV
Checked By:

USERNAME 5/28/2009 10:30:03 AM
 C:\G\13821807-Waterfront\ldgn\Section5.dgn

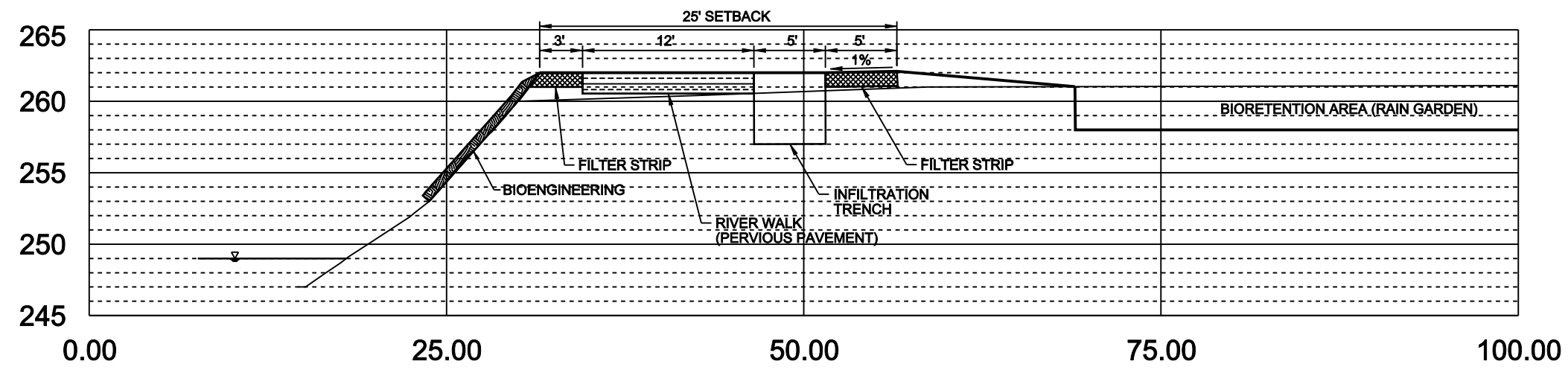

SCALE:
 H = 1":10'
 V = 1":10'

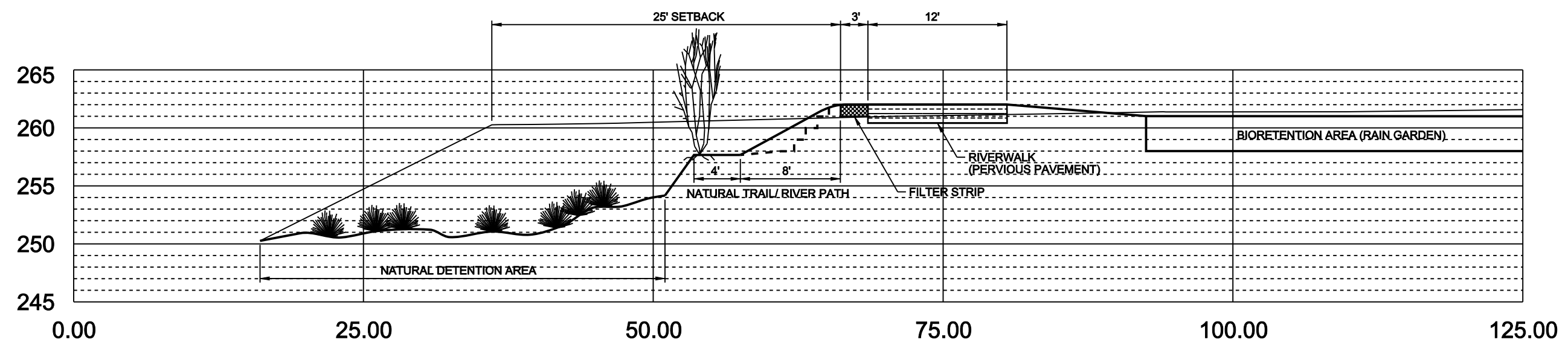

SCALE:
 H = 1":10'
 V = 1":10'

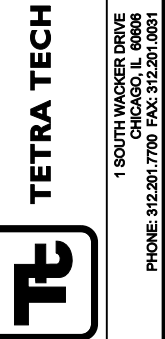

RIVERFRONT LID
 TYPICAL SECTION

BY	DATE	DESCRIPTION
DGS		

Client: EPA
 Project Location: ALLENTOWN, PA
 THE WATERFRONT
 BROWNFIELDS SUSTAINABILITY
 PILOT PROJECT

Project No.: 103DG1382-1806.02
 Designed By: TXH
 Drawn By: KFY
 Checked By:

SHT-5
 5 of 6
 Copyright: Tetra Tech

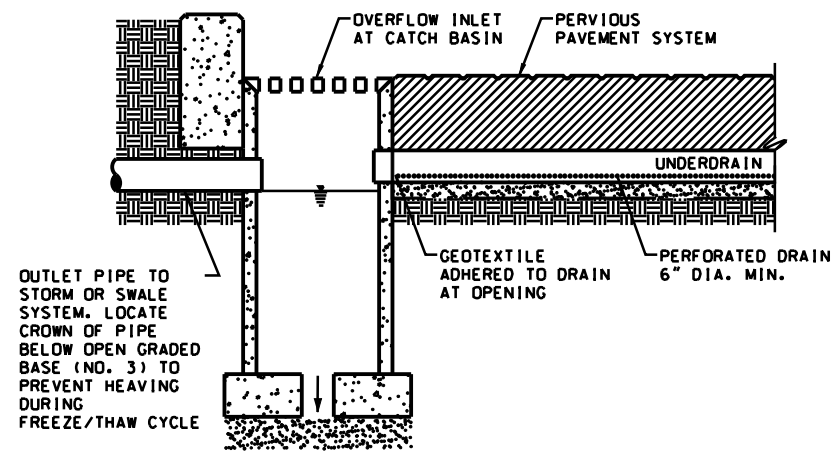

**PERVIOUS PAVEMENT SYSTEM WITH UNDERDRAIN
SITE REDEVELOPMENT**

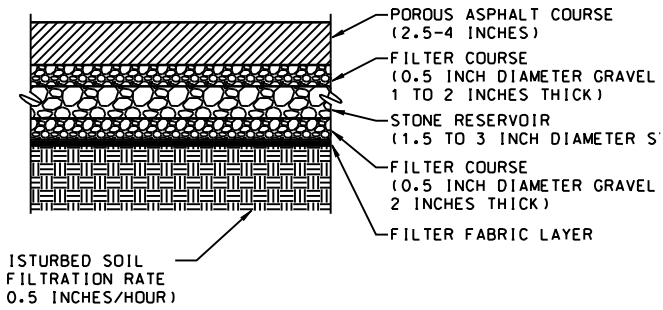

**PERVIOUS ASPHALT PAVEMENT DETAIL WITHOUT UNDERDRAIN
SITE REDEVELOPMENT**

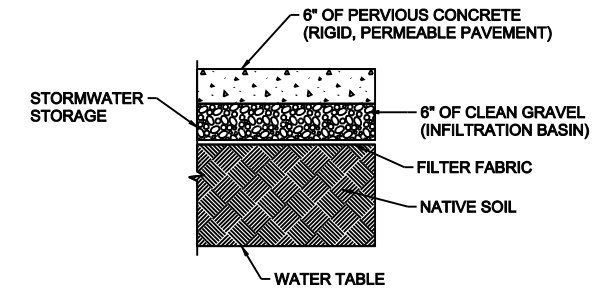

**PERVIOUS CONCRETE PAVEMENT DETAIL WITHOUT UNDERDRAIN
SITE REDEVELOPMENT & RIVERFRONT**

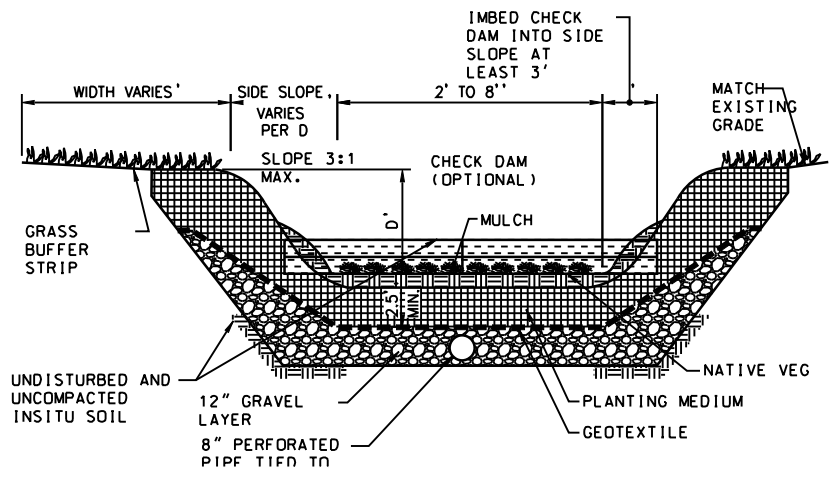

**VEGETATED SWALE
SITE REDEVELOPMENT**

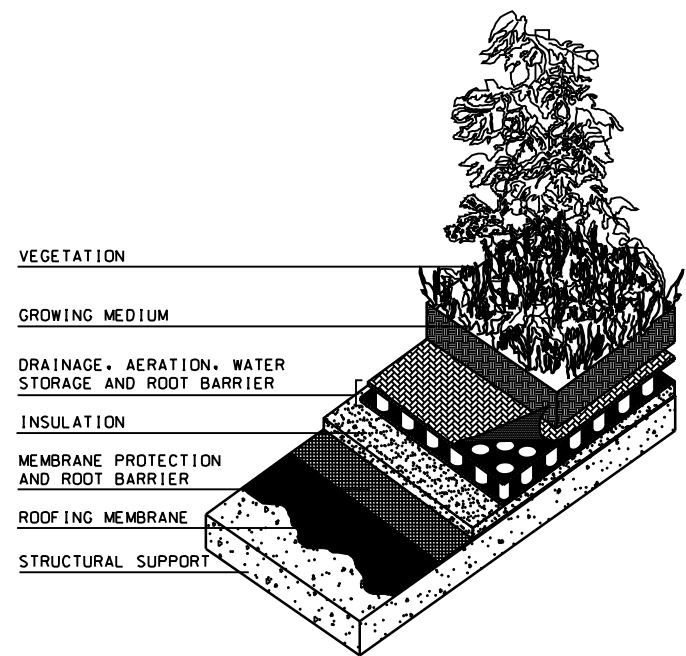

**GREEN ROOF
SITE REDEVELOPMENT**

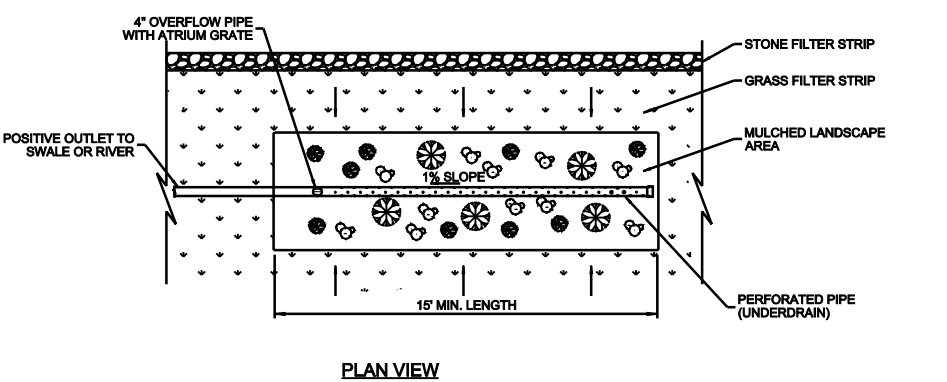
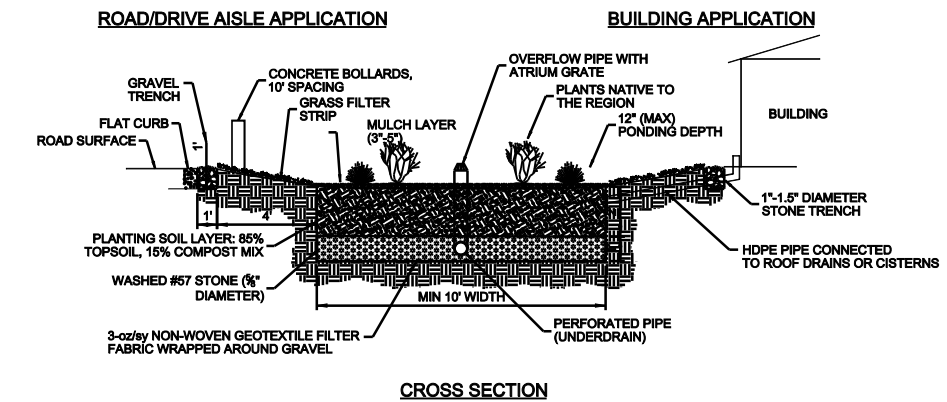

**TYPICAL BIORETENTION AREA (RAIN GARDENS)
SITE REDEVELOPMENT**

BY	DATE	DESCRIPTION
DGS		

Client: EPA
Project Location: ALLENTOWN, PA
**THE WATERFRONT
BROWNIELDS SUSTAINABILITY
PILOT PROJECT**

Project No.: 103DG1382-1806.02
Designed By: TXH
Drawn By: KJV
Checked By:

ATTACHMENT C

FEMA FLOODPLAIN MAPS FOR THE WATERFRONT SITE

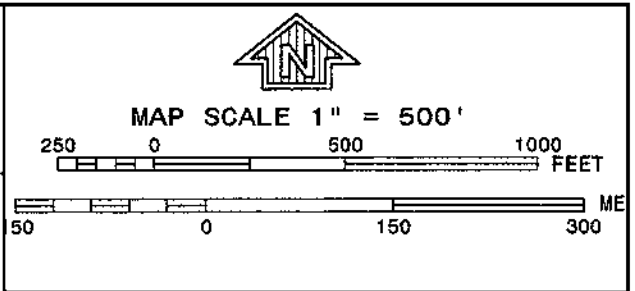
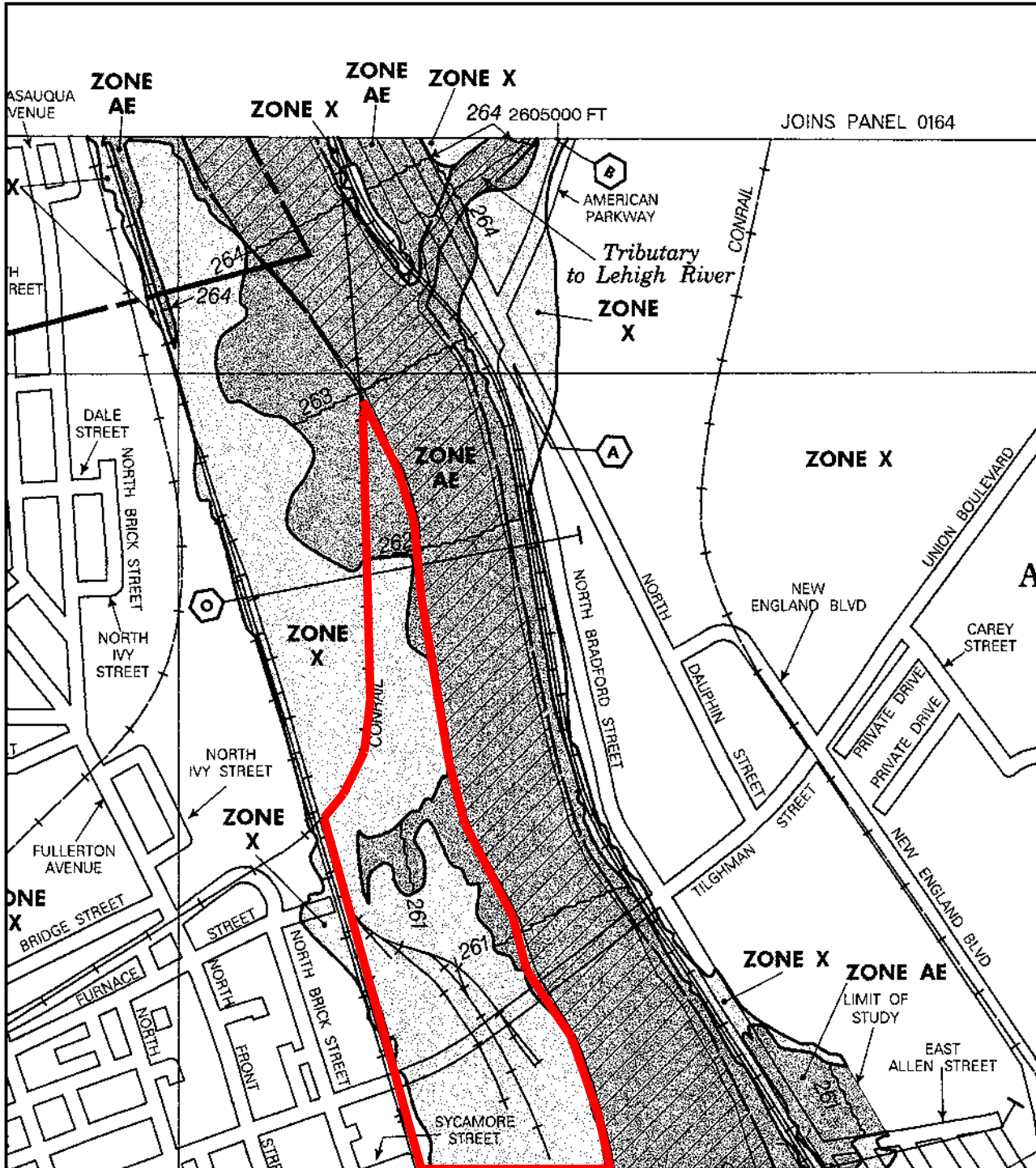

PANEL 0252F

FIRM
FLOOD INSURANCE RATE MAP
LEHIGH COUNTY,
PENNSYLVANIA
(ALL JURISDICTIONS)

PANEL 252 OF 340
 (SEE MAP INDEX FOR FIRM PANEL LAYOUT)

CONTAINS:

COMMUNITY	NUMBER	PANEL	SUFFIX
ALLENTOWN CITY OF	420585	0252	F
SALISBURY TOWNSHIP OF	420581	0252	F
WHITCHALL TOWNSHIP OF	420595	0252	F

Notes to User: The Map Number shown below should be used when placing map orders; the Community Number shown above should be used on insurance applications for the subject community.

MAP NUMBER
42077C0252F

MAP REVISED
JULY 16, 2004

Federal Emergency Management Agency

This is an official copy of a portion of the above referenced flood map. It was extracted using F-MIT On-Line. This map does not reflect changes or amendments which may have been made subsequent to the date on the title block. For the latest product information about National Flood Insurance Program flood maps check the FEMA Flood Map Store at www.msc.fema.gov

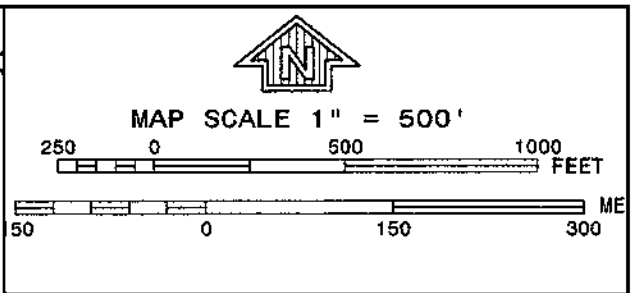
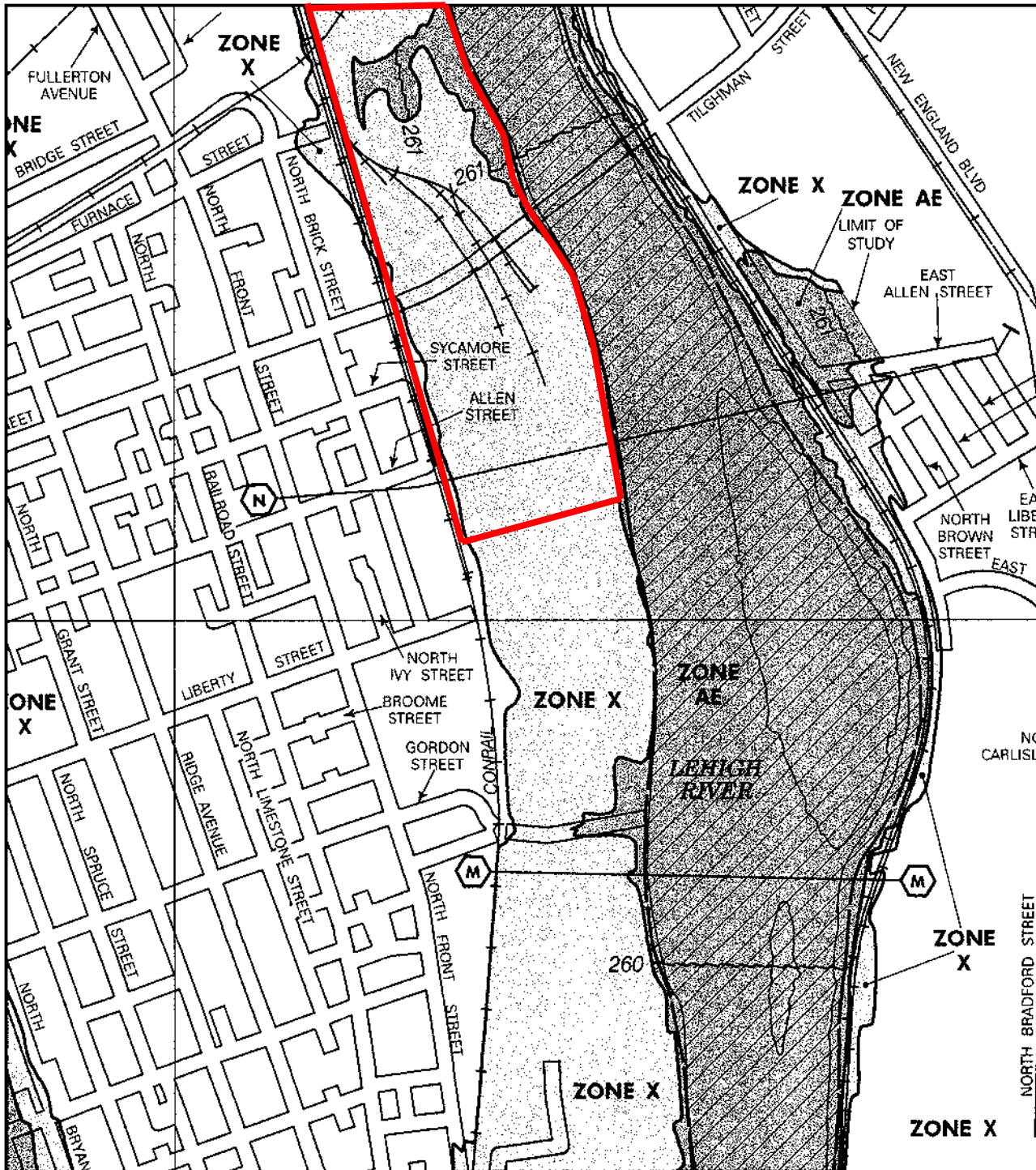

PANEL 0252F

**FIRM
FLOOD INSURANCE RATE MAP
LEHIGH COUNTY,
PENNSYLVANIA
(ALL JURISDICTIONS)**

PANEL 252 OF 340
(SEE MAP INDEX FOR FIRM PANEL LAYOUT)

CONTAINS:

COMMUNITY	NUMBER	PANEL	SUFFIX
ALLENTOWN, CITY OF	420595	0252	F
SALISBURY, TOWNSHIP OF	420581	0252	F
WHITCHALL TOWNSHIP OF	420595	0252	F

Notes to User: The Map Number shown below should be used when placing map orders; the Community Number shown above should be used on insurance applications for the subject community.



**MAP NUMBER
42077C0252F**

**MAP REVISED
JULY 16, 2004**

Federal Emergency Management Agency

This is an official copy of a portion of the above referenced flood map. It was extracted using F-MIT On-Line. This map does not reflect changes or amendments which may have been made subsequent to the date on the title block. For the latest product information about National Flood Insurance Program flood maps check the FEMA Flood Map Store at www.msc.fema.gov