

US EPA ARCHIVE DOCUMENT

Green Streetscapes Study
Oakman Boulevard, Detroit Michigan
(A Focus: HOPE Community Development Area)



Prepared for:
U.S. Environmental Protection Agency
Office of Solid Waste and Emergency Response
Office of Brownfields and Land Revitalization
Washington, DC 20460



Prepared by:
Tetra Tech Architects & Engineers
215 The Commons
Ithaca, NY 14850



SRA International, Inc. (Contract No. EP-W-07-023)
3434 Washington Boulevard
Arlington, VA 22201

Table of Contents

1. INTRODUCTION 1

1.1. What is the Purpose of the Study? 1

1.2. How to Use This Document 1

2. “GREEN” STREETSCAPES DESIGN OBJECTIVES 3

2.1. Improve Air Quality 3

2.2. Reduce Heat Island Effects 4

2.3. Improve Water Quality 5

2.4. Enhance the Urban Forest and Wildlife Habitat 6

2.5. Mitigate/Rehabilitate Brownfield Conditions 7

3. “GREEN” STREETSCAPE DESIGN STANDARDS 10

3.1. Streetscape Geometry 11

3.2. Paving Materials 12

3.3. Stormwater Management Facilities (SMFs) 15

3.4. Landscaping 20

3.5. Furniture and Fixtures 22

3.6. Bicycle Facilities 24

4. APPLYING THE GUIDELINES 25

5. OAKMAN BOULEVARD “GREEN” STREETSCAPE CONCEPT 26

5.1. Site Analysis 26

5.2. Existing Conditions 27

5.3. Conceptual Design 28

5.4. Future Bike Lanes and Intersection Improvements 34

5.5. Crosswalk Design 37

6. APPENDIX 39

6.1. Construction Details 39

6.2. Bioretention Basin Soil Specification 40

6.3. Recommended Plant Lists 43

6.4. SMF Maintenance Guidelines 47

6.5. Streetscape SMF Sizing Guide 48

6.6. Potential LEED credits in Streetscape Development 51

I. INTRODUCTION

I.1. What is the Purpose of the Study?

The U.S. Environmental Protection Agency (EPA) Brownfields Program empowers states, communities, and other stakeholders to work together to prevent, assess, safely clean up, and sustainably reuse brownfields. Under this program, EPA's Brownfields Sustainability Pilots are providing technical assistance to support communities in achieving greener, more sustainable assessment, cleanup, and redevelopment at their brownfields projects. EPA selected Focus: HOPE in Detroit, MI, as a Brownfields Sustainability Pilot. Focus is a non-profit organization that is working with its local partners to revitalize several buildings and properties, including a Brownfield site. As part of this pilot, Tetra Tech TGI and Tetra Tech EM Inc. (Tetra Tech), through a subcontract to SRA International, Inc., provided assistance to support the integration of sustainable streetscapes and site-specific stormwater management approaches for the Brownfield site and the adjacent properties undergoing redevelopment. This document provides the technical assistance outputs agreed upon with the team including: an introduction to green streetscape concepts, sample specifications, and other details to support implementation.

I.1.1. For Whom and for What?

The success of urban development relies heavily on the surrounding physical environment. Streets are a vital

component of the urban fabric, having the ability to both positively or negatively affect attitudes about a place. Streets are necessary for bringing people to a place but their design also influences where people are persuaded to stop. This study presents developers, designers and policy makers with essential components for achieving successful "Green" streets. By adhering to pre-determined guidelines and design principles streets are more likely to reflect the spirit of a place or neighborhood. The injection of design elements consistent with city wide standards creates a continuity which can integrate new developments with old.

I.1.2. What are Green Streetscapes?

Several attributes of good streetscape design are inherently "Green", such as street trees and improved pedestrian environments which encourage walking; however widespread agreement on the merits of sustainable development compel all design standards to be "Green" as a matter of best practice. Therefore "Green" streetscapes are simply those which adhere to well established standards of sustainable design.

I.2. How to Use This Document

While many of the Green Streetscape components outlined in this study are universally relevant, the focus of this document is a demonstration of their application for specific properties being redeveloped along Oakman Blvd. The study presents

seven essential “Green Streetscape Design Objectives” which are described in Chapter 2. All “Green” streetscape designs should include elements which meet each of the design objectives. Chapter 3 describes a series of design components or “Streetscape Standards”. These standards are detailed descriptions or examples of streetscape elements which a designer may use to achieve the objectives set out in Chapter 2. Chapter 4 provides a matrix which illustrates design standards that meet the various design objectives. Filling in a similar matrix is a good exercise for establishing a project’s scope early on in the design process. Chapter 5 puts the “Streetscape Standards” into practice by demonstrating their application to redevelopment efforts along Oakman East in Detroit’s Central Woodward/ North End. A conceptual design for Oakman Blvd includes specific construction details for the site area where the planned redevelopment meets the street, taking environmental conditions of the property into consideration. The resulting stormwater management and streetscape designs become a prototype for other streetscapes in the area or streets elsewhere that reside within similar contexts. Chapter 6 contains option specific details, technical specifications, and other information which can help designers begin to develop construction documents for implementation within the Focus: HOPE, Oakman East redevelopment area.

2. “GREEN” STREETSCAPES DESIGN OBJECTIVES

1. Improve Air Quality
2. Reduce Heat Island Effects
3. Improve Water Quality
4. Enhance the Urban Forest and Wildlife Habitat
5. Reduce Light Pollution
6. Mitigate/Rehabilitate Brownfield Conditions

The “Green” benefits of persuading people to leave the car at home and walk to their destinations are well understood. Many urban streetscape guidelines provide instructions for enhancing the pedestrian environment to create accessible pedestrian corridors which are both functional and attractive. However, while ‘walkability’ is a key objective of good streetscape design, streetscapes have the potential to meet several additional sustainable design objectives.

2.1. Improve Air Quality

The link between air quality and human health has long been a concern, one which has become more acute as more and more of the world’s population live in urban areas. In North

America, transportation pollution has replaced industrial pollution as the main contributor to poor air quality in urban areas. Transportation accommodations dominate the layout and design of our urban environments enabling the volume of vehicular traffic to explode in recent decades. It has become obvious that in addition to designing “cleaner” transportation it is also important to reduce the volume of traffic in order to improve urban air quality. Therefore street design has been recognized as critical to improving urban air quality.

2.1.1. Enhancing the Pedestrian Environment

Streetscape design can achieve improved air quality by encouraging people to walk rather than drive, resulting in fewer greenhouse gas emissions. The following are design priorities for creating successful pedestrian environments:

Attractive Environments

- Shade
- Site Furniture
- Civic Art
- Quality Materials

Way-finding

- Signage and Symbology
- Community Identification
- Materials, Textures

Security

- Reduced Visual Obstructions
- Adequate Lighting

Universal Accessibility

- Barrier Free
- Urban Braille (*textural cues for the blind*)

2.1.2. Street Trees

Street trees are important streetscape elements which serve to meet several “Green” Streetscape design objectives including improving air quality. In the article “Urban Street Trees, 22 Benefits”, Dan Burden lists several of these qualities:

- Automobile emissions. Street trees can significantly reduce the impact of automobile emissions including carbon monoxide (CO), volatile organic compounds (VOC), nitrogen oxides (NOx), and particulate matter (PM).
- Gas transformation efficiency. Street trees within the city absorb 9 times more pollutants than trees outside the city, converting harmful gases back into oxygen and other useful and natural gases.
- Lower Ozone. The combination of the higher urban street temperatures and tailpipe emissions dramatically increase the conversion of harmful ozone and other gases into more noxious substances that have an adverse effect on human health. Street trees lower temperatures and thereby help lower ozone generation.

2.2. Reduce Heat Island Effects

Temperatures in urban areas are often several degrees warmer than the rural surrounding area especially during the hot

summer months. Acres of urban asphalt and concrete pavement which comprise city streets contribute to this condition. The higher air temperatures cause:

- Increased energy consumption as air conditioners are employed to cool indoor spaces.
- Elevated emissions of air pollutants and greenhouse gases.
- Compromised human health and comfort.
- Impaired water quality: warm stormwater runoff raises downstream temperatures with detrimental effects on aquatic flora and fauna.

2.2.1. Street Trees

Street trees are capable of significantly lowering urban air temperatures. Where street trees create a continuous overhead canopy, temperature differentials of 5-15 degrees are felt. However, human comfort is not the only benefit of shady streets. Well shaded streets also shade homes and create a cooler microclimate around them which can reduce household energy bills from 15-35%.

2.2.2. Designing “Cool” Streets

Conventional asphalt pavements can reach peak summertime surface temperatures of 120–150°F. The properties of conventional pavements, particularly black asphalt also make them very effective at storing heat. During the summer these

pavements release heat throughout the night time. Using light colored pavements which reflect more solar energy results in cooler paved environments. According to the EPA's document, *Reducing Urban Heat Islands*, light gray and tan colors can reduce pavement surface temperatures by 20 to 40°F (11°C to 22°C). Porous pavement can also be cooler as water is retained as it passes through the pavement.

Asphalt options for reducing heat island effect include:

- Open graded asphalt surfaces on top of dense pavements
- Porous pavement systems
- Light colored pavements, which incorporate:
 - Light colored aggregates (which increase solar reflectance)
 - Synthetic binders (which can be any color)
 - Durable surface coatings applied to the asphalt surface
 - Light-colored resin modifiers

Other paving materials which can reduce the Heat Island Effect through increased solar reflectance or water retention are:

- Standard Portland concrete (some pigments can further improve solar reflectance)
- Porous block pavement systems (water retention and increased solar reflectance)
- Plastic grid pavement systems (water retention)

- Certain light colored brick pavers (increased solar reflectance)

2.3. Improve Water Quality

Streets are one the largest sources of Nonpoint Source Pollution. This section describes issues concerning urban stormwater management and how various streetscapes features can help mitigate a city's negative impact on water quality.

2.3.1. Stormwater Management

The National Pollutant Discharge Elimination System (NPDES) permit program controls water pollution by regulating sources which discharge pollutants directly to waters of the United States. The goal of the program is to limit pollutants associated with industrial waste water and non-point stormwater from discharging to natural water bodies. As regulations become more and more stringent, civil engineers and landscape architects have developed innovative methods for meeting the regulations in ways that are more cost effective and aesthetically pleasing. Stormwater management facilities act to filter out pollutants from runoff, detain water to reduce flooding and limit erosive conditions downstream, and infiltrate stormwater to recharge groundwater and aquifers. Where streets are concerned, stormwater experts have recognized that managing stormwater locally can reduce the runoff reaching downstream facilities and have dramatic effect on the size and cost of those measures. A "Green" street design endeavors to provide as many opportunities to detain, filter and

infiltrate stormwater as possible and do it in a manner which creates an esthetic interest for the streetscape.

2.3.2. Combined Sewer Overflows

(CSOs) which combine stormwater and sanitary sewers are a serious contributor to water pollution. When heavy rainfall events occur, the water volume in a combined sewer can overwhelm the pipe network and sewage treatment plants, spilling sewage into local streams and rivers. The Clean Water Act requires that communities dramatically reduce or eliminate their combined sewer overflows. Some cities have constructed costly underground stormwater storage facilities to reduce the flow of water to their treatment facilities so that they are not overwhelmed and sewage doesn't overflow the system before being treated. Installing rain gardens, permeable pavements, roof gardens, blue roofs, or even grassy swales or ditches along roadways can help to reduce the volume of stormwater taxing sewer systems. Diverting stormwater to these types of mostly low tech and cost effective facilities diminishes flows to the sewers and allows soil and vegetation to filter runoff while groundwater supplies are replenished.

2.3.3. Street Trees

Street trees can allow site designers to use less drainage infrastructure. Trees use and transpire back to the air a significant percentage of the rain which falls on and near them; this reduces stormwater volumes. The first 30% of most precipitation is absorbed through its leaf system, allowing evaporation back into the atmosphere. An additional percentage (up to 30%) of precipitation is absorbed back into

the ground, retained and absorbed by the root structure, and then transpired back to the air. Any water that is not ultimately taken up by the tree will naturally percolate into the ground to recharge the groundwater and aquifers.

2.4. Enhance the Urban Forest and Wildlife Habitat

Paved surfaces account for 30-45% of land cover in urban areas with buildings accounting for much of the remaining surface area. With this in mind it becomes clear that landscaping street right-of-ways and medians is critical to creating a sustainable urban forest. Street vegetation can provide habitat and food for wildlife as well as places to rest, hide and move through. Streets trees can create "green" links or corridors between urban open spaces. Connectivity between larger parks and preserves increases the habitat value of the urban forest.

2.4.1. Reduce Light Pollution

Pedestrian safety and nighttime aesthetics often seem to be at odds with anti-light pollution standards. Sustainable Streetscape design must balance public safety and comfort with efficient, minimalist and non-polluting lighting.

2.4.2. Dark Sky Standards

To the maximum extent possible, lighting should be low intensity and conform to "Dark Sky" standards of downward projected, "full cut-off" illumination that shields light from being emitted upwards toward the night sky or surrounding

natural areas. To be full cut-off, the light bulb should not extend below the lamp shade.

2.5. Mitigate/Rehabilitate Brownfield Conditions

Sites where previous land use has complicated expansion, redevelopment or reuse because of the presence or potential presence of toxic residue are referred to as Brownfields. Special design consideration must be given to some streetscape elements where they are installed over Brownfield sites. Brownfields soils may include contaminants that must be removed or managed to prevent risks to human health and the environment. Stormwater management facilities must be carefully designed to prevent exacerbation of the existing contaminated condition. Stormwater management facilities are beneficial however, where they can prevent runoff from flowing onto nearby contaminated areas as this diminishes the leaching of contaminants into the groundwater which may be occurring under existing conditions.

2.5.1. General Guidelines to Brownfield Design

Designs for developing Brownfield sites should only be done by qualified and experienced site designers. The following bullets provide information that organizations planning on developing Brownfield sites should be aware of:

- Ideally site remediation is completed before, or done in conjunction with, site redevelopment.
- Understand the contamination on site, the extent of the location(s) of contamination, the maximum

concentrations of the contaminants, and the risks associated with the contamination remaining in place. Testing should be performed by a qualified testing agency.

- When the contaminants on a site pose a threat to human health and the environment, the development proposal must first go through a due care review process mandated by the Michigan Department of Environmental Quality.
- Careful attention must be paid to redevelopment work occurring where soil remediation has occurred, particularly where utility trenches are being cut. Utility trenches become preferred pathways for contaminants as the free draining bedding material can flow contaminated water from a contained area to new unspoiled locations.
- Actions that cause contamination to migrate beyond the source property boundaries at levels above cleanup criteria are considered “exacerbation.” Consequences associated with exacerbation of existing conditions are identified and enforced under Michigan’s cleanup programs.

The following page identifies some more specific guidelines for Brownfield development specifically in the state of Michigan.

The University of Michigan's School of Natural Resources and Environment developed the following design guidelines as part of a planning project that used low impact development (LID) techniques on contaminated sites. The following guidelines were reviewed and adapted by the Michigan Department of Environmental Quality for their "LID Manual for Michigan."

- Avoid infiltration practices in contaminated areas. If infiltration is proposed and contaminated areas cannot be avoided, additional testing could demonstrate that residual contamination will not leach from the percolation of rainfall through the contaminated soils to groundwater in concentrations that present an unacceptable risk. If leach testing demonstrates infiltration would result in additional unacceptable concentrations reaching the groundwater, design considerations to separate contaminated soils from contact with stormwater must be included.
- LID practices on brownfield sites may include treatment and storage with reuse of stormwater rather than complete infiltration. Most brownfields that have residual contamination need caps, so vegetated areas need to be located above caps and fitted with underdrain systems to remove stormwater or reservoirs to capture it for later use.
- Detention, retention, and biofiltration are suitable for contaminated sites when designed to prevent exfiltration to underlying soils and allow adequate time

for water to be in contact with plants and trees for bioremediation. Infiltration trenches and basins collect stormwater and infiltrate or attenuate runoff. If fitted with filter devices for pre-treatment of contaminated water, these become wastewater treatment systems subject to requirements of NPDES permits.

- Permeable pavement and rain gardens are not usually suitable for sites with residual contamination that could be mobilized to groundwater, or to the storm sewer system in cases where these structures are underdrained. Additional features including impermeable liners can be coupled with modified LID practices to safely filter and manage stormwater without exposing the water to contaminated soils.
- Retain/revegetate trees and vegetation. Retaining and revegetating helps evapotranspire stormwater runoff while intercepting large amounts of rainfall that would otherwise enter waterways as runoff.
- Use impervious surfaces as additional caps. When siting the development, consider locating buildings and other impervious surfaces over contaminated areas as long as escaping vapors or other contaminants are not present or are controlled to prevent health risks. For example, one could strategically locate a parking area over a small, contaminated area.
- Implement practices that encourage evapotranspiration and capture/reuse water. Green roofs are an ideal way

to reduce runoff from building roofs by encouraging evapotranspiration of rainwater. Another option for brownfield sites is to capture and reuse stormwater for non-potable uses. This can include runoff storage in rain barrels for irrigation of green roofs or landscaped areas, or in cisterns that store rainwater for toilet flushing and other uses.

- Include LID techniques in sites around brownfield areas. New and redeveloped sites near brownfields should use green infrastructure practices to prevent additional runoff from flowing onto potentially contaminated areas.

3. "GREEN" STREETSCAPE DESIGN STANDARDS

Design standards are specific guidelines and details for landscape features which can make up a streetscape design. This section will illustrate general standards for streetscape layout and detail those landscape features which are best suited to achieving the "Green" design objectives.

-  Landscape
-  Paving Materials
-  Stormwater Management
-  Furniture and Fixtures

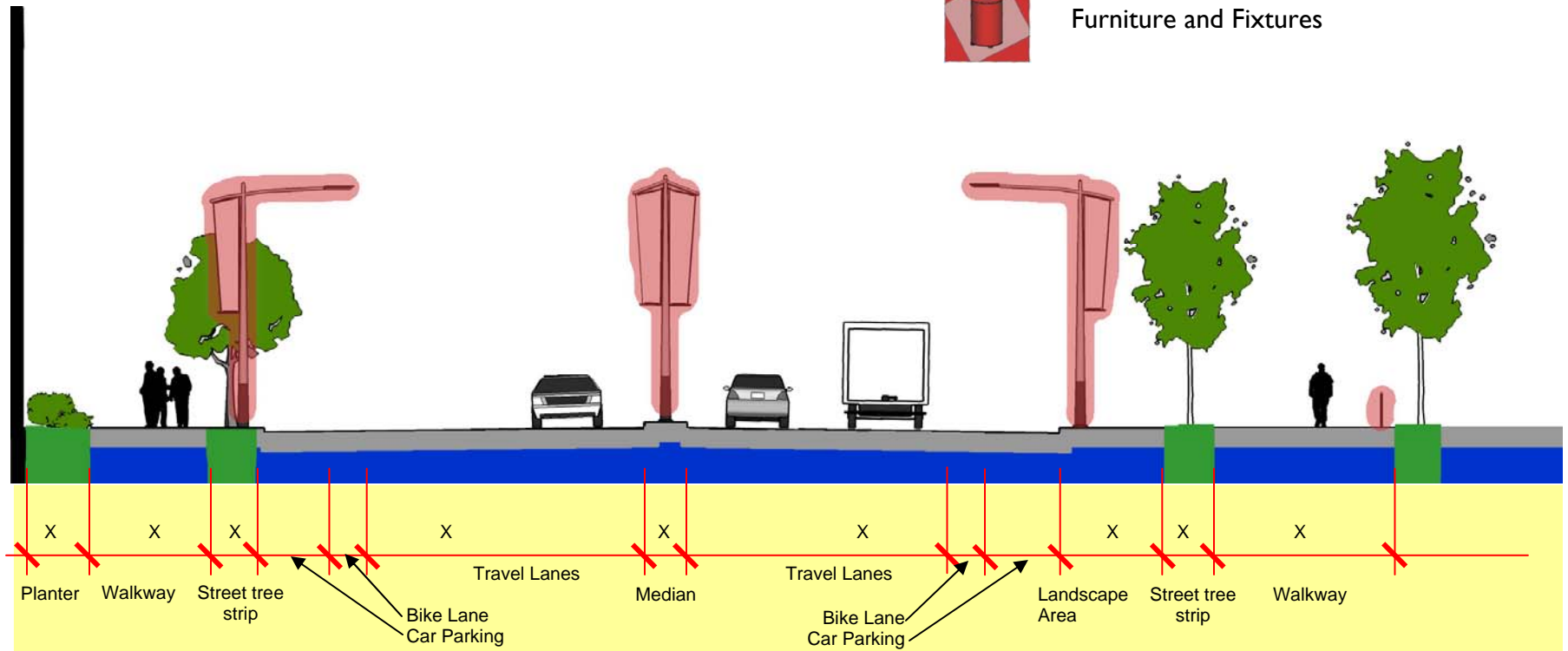

Anatomy of a Green Streetscape

3.1. Streetscape Geometry

Whether you are designing a new pedestrian environment for an existing street, redeveloping an entire right of way or designing a brand new street, the first step is to establish the geometry. City and municipal traffic engineering departments have standards for major street alignments and planning documents may describe land use and street hierarchies. Project engineers, architects and landscape architects will synthesize all of the controlling factors to create a design that is safe, functional and appealing. Green streetscapes require an even higher level of coordination between project designers and municipal representatives. Variances are often required to meet some “Green” street design objectives as they require geometries and utility solutions which don’t meet the established planning ordinances or engineering standards. For example, conflicts commonly arise when pavement reductions to reduce impervious surfaces are proposed because standards for travel lane widths and zoning ordinance parking formulas establish default street widths. These types of conflicts can better be identified and addressed through early planning and communication between all interest groups to establish a common vision of the project goals and objectives.

Green Objectives

- Use minimum travel lane widths where possible to reduce impervious surface area.
- Provide linear opportunities for street tree plantings.
- Utilize traffic calming for slow speed streets – narrow lanes, curb bump-outs and center median pedestrian refuge.
- Provide opportunities for alternative transportation, including public transit and bicycling.
- Create walkable streets – accessible, unobstructed pedestrian corridors.

3.2. Paving Materials



Pavement is an essential component of any streetscape but it is often overlooked as a feature. If a street appears “generic” or un-memorable you probably don’t even think about the paving materials unless they are in very poor condition. Uniquely paved streetscapes which break the monotony of the ubiquitous grey surfaces we see daily can elevate our impression of a place. Consequently, the vast palette of available paving materials becomes an important tool in the streetscape designer’s toolbox. Many paving materials are available in different colors, patterns and textures which add visual interest to a street. However, of particular importance to the objective of these guidelines are their sustainable attributes. Paving materials may be selected for reflectivity, green manufacturing, local sourcing and permeability.

Green Objectives

- Use permeable paving where appropriate to reduce stormwater runoff and allow for groundwater recharge.
- Use “Cool Pavements” wherever possible to reduce the Urban Heat Island Effect.
- Use locally sourced paving materials manufactured with sustainable practices to reduce life-cycle environmental impacts.

Pervious Pavements

- Are increasingly being recognized by regulators as structural stormwater Best Management Practices (BMPs).
- Stormwater runoff is significantly reduced, infiltration for ground water recharge is increased
- Roof leaders may be connected to storage beds below pervious pavements, reducing on-site stormwater volume requirements
- The initial cost of permeable pavement may be higher than conventional, impermeable technologies, but these costs are often offset by savings from reduced requirements for grading, treatment ponds, or other drainage features, such as inlets and stormwater pipes (EPA: *Reducing Stormwater Costs*)
- Where communities have combined sewers, there could be environmental, social, and cost benefits from reducing combined sewer overflows, as well as potentially avoiding part of the increased infrastructure costs associated with combined sewer operation. (EPA: *Reducing Stormwater Costs*)

Porous Asphalt

Porous Asphalt is a flexible pavement which allows water to flow through it rather than over it as water does with traditional asphalt. Like traditional asphalt pavement, porous asphalt is a bituminous substance derived from crude oil which binds together select stone aggregates and sand to form a durable wear layout over a stone base. Porous asphalt achieves its porosity by eliminating the fine particles from its mix specification.

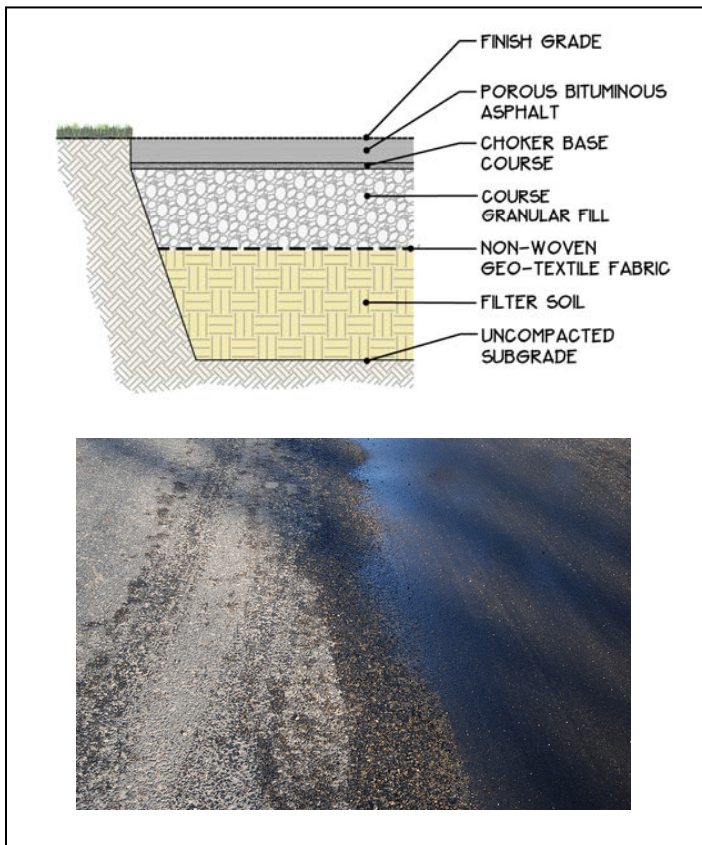

Pervious Concrete

Pervious Concrete achieves porosity by reducing the amount of fines in the mix just like Porous Asphalt. The voids in the concrete pavement give the surface a much coarser appearance compared to standard impervious concrete. The low mortar content and increased void space reduces strength compared to standard concrete however sufficient strength is achieved for all but heavy duty applications. Pervious concrete is not suitable for high traffic roadways.

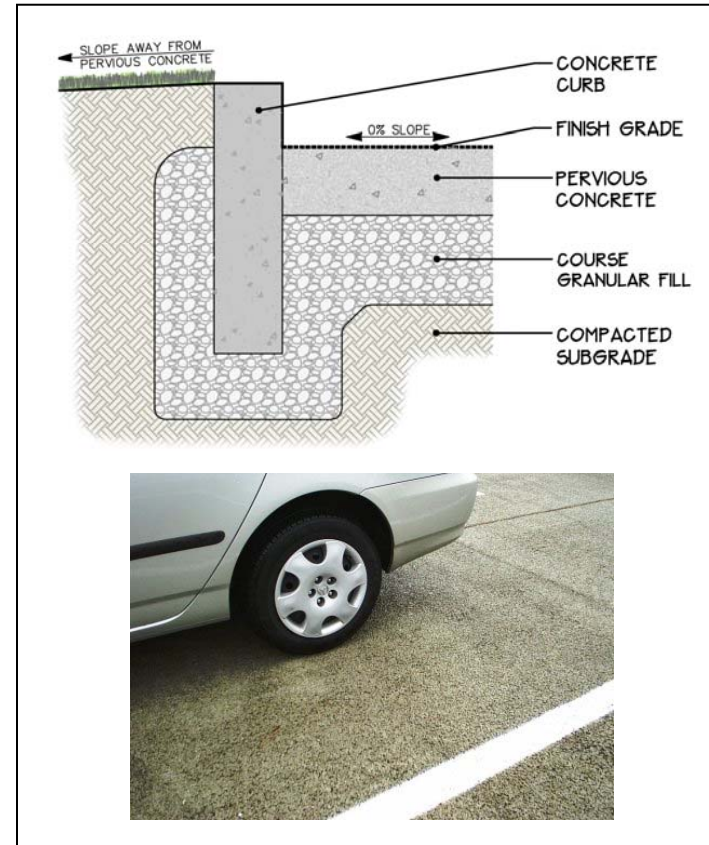

Permeable Paver Blocks

Permeable Paver Blocks are manufactured units which interlock to create a durable pavement. Designs vary but all permeable systems leave surface void spaces which are filled with permeable materials such as pea gravel, sand or soil, allowing surface water to infiltrate.

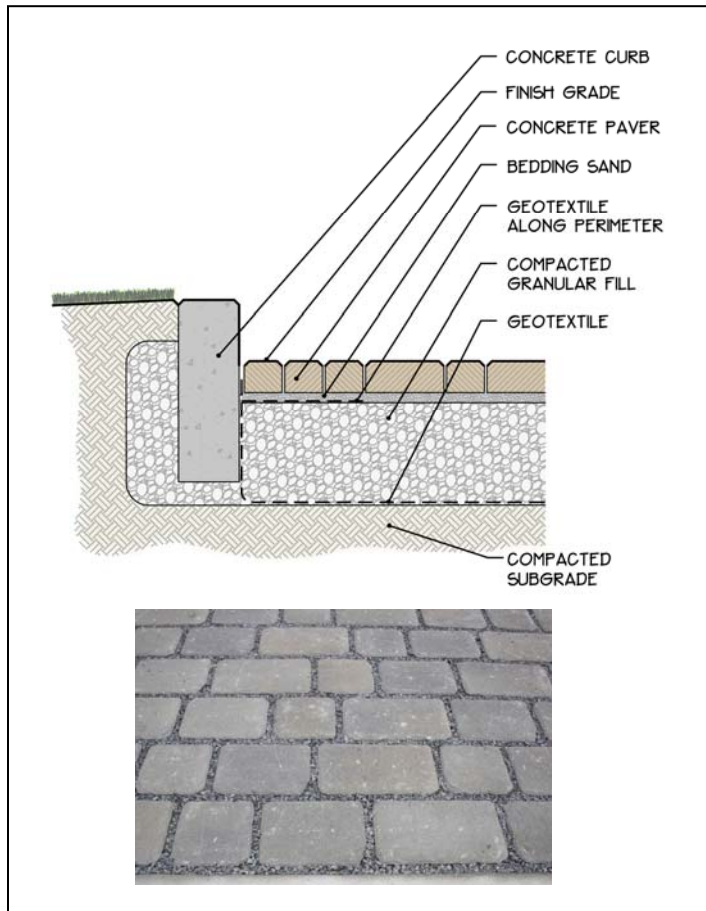

Permeable Paving Do's and Don'ts

- Shouldn't be used on slopes of more than 5%
- In areas with poorly draining soils, infiltration beds below pervious pavements may be designed to slowly discharge to adjacent bioretention areas.
- Provide a backup method for water to enter the storage bed in the event of pavement failure.
- Infiltration beds should have level bottoms.
- Should not be placed on recent fill or compacted fill less than 5 yrs old as the infiltrated water could destabilize the fill.
- Soil infiltration tests are required to ensure adequate infiltration rates and for sizing storage beds.

3.3. Stormwater Management Facilities (SMFs)

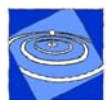

Traditionally, streets have not been considered part of the stormwater management solution in civil design. In fact, the impervious surfaces which make up our streets create stormwater runoff and civil designers typically utilize underground infrastructure to whisk the water away so that it doesn't pond and flood our cities. Only recently have designers and engineers considered using streetscape elements to help deal with rainwater where it lands. Today streetscape designers can utilize many innovative stormwater management techniques designed not only to store and/or infiltrate stormwater but also to filter out pollutants to improve water quality before water makes its way to aquifers, streams and lakes.

Green Objectives

- Improve water quality by filtering out Nonpoint Source Pollution.
- Reduce the load on Combined Sewer Overflows by reducing stormwater runoff volumes entering the sewer system.
- Infiltrate stormwater for groundwater and aquifer recharge, wherever possible.

3.3.1. Constructed Filter

When space does not permit the use of above ground stormwater management facilities such as Stormwater Planters or Rain Gardens, Constructed Filters are useful water quality treatment facilities. These structures are excavated areas backfilled with a filter media composed of a layer of sand, compost, organic material, peat, or other media. This filter media is designed to filter out pollutants such as sediments, metals, and hydrocarbons, from stormwater runoff.

Filter Example

There are many filter designs. The diagram below illustrates a small filter ideal for hot spot pretreatment particularly useful where you may have a known pollutant source that needs to be reduced before stormwater enters subsequent stormwater facilities.

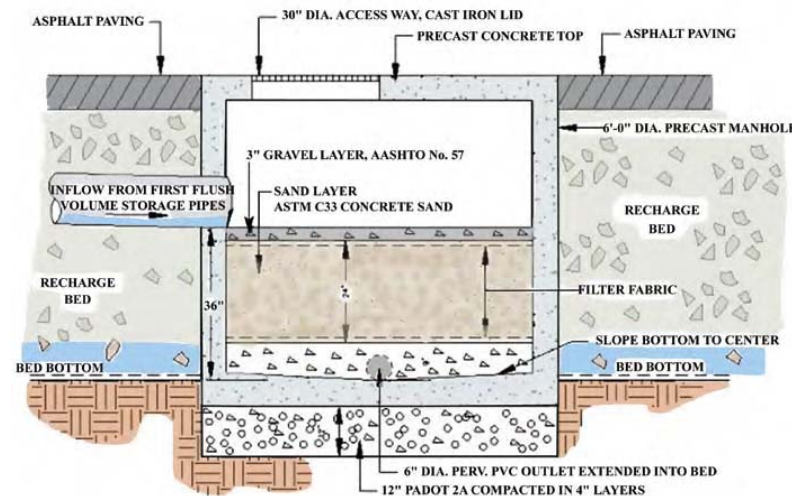

Source: Pennsylvania Stormwater BMP Manual

3.3.2. Bio-Retention Facilities

Bio-Retention facilities utilize biological processes for the removal of stormwater run-off pollutants. These facilities can range in appearance from created wetlands to hardscape features which are designed to mimic natural bioremediation processes. Although physical appearances may vary dramatically from facility to facility, they all contain growing media and vegetation. As water pools in the facility it infiltrates through the growing media and is filtered. Site soil conditions dictate the final stage in the bio-retention facility. Where soils are free draining and not contaminated, water can be allowed to completely infiltrate for groundwater re-charge. Where soils are poorly drained the facility will include gravel beds and underdrains to move water from the facility in the event of heavier rain events.

- Bio-Retention System Components
- Pretreatment
 - Flow Inlet
 - Ponding Area
 - Plant Material
 - Organic Layer or Mulch
 - Planting Soil/volume Storage Bed
 - Positive Overflow

Stormwater Planters

Stormwater Planters receive runoff from multiple impervious surfaces. This runoff is used to irrigate the vegetation in the planter and prevents stormwater from directly draining into

nearby sewers. Stormwater Planters also play an important role in urban areas by minimizing stormwater runoff, reducing water pollution, and creating a greener and healthier appearance of the built environment by providing space for plants and trees near buildings and along streets. There are three main types of stormwater planters which can be used on sidewalks, plazas, rooftops, and other impervious areas: contained, infiltration, and flow-through. Where Stormwater Planters are constructed over contaminated soils they will be “contained” type facilities which include impervious bottoms or liners to ensure pollutants do not leach into the groundwater. The primary function of contained facilities is filtration, although there is some volume reduction through evaporation and transpiration. The following page provides examples of Stormwater Planter applications.

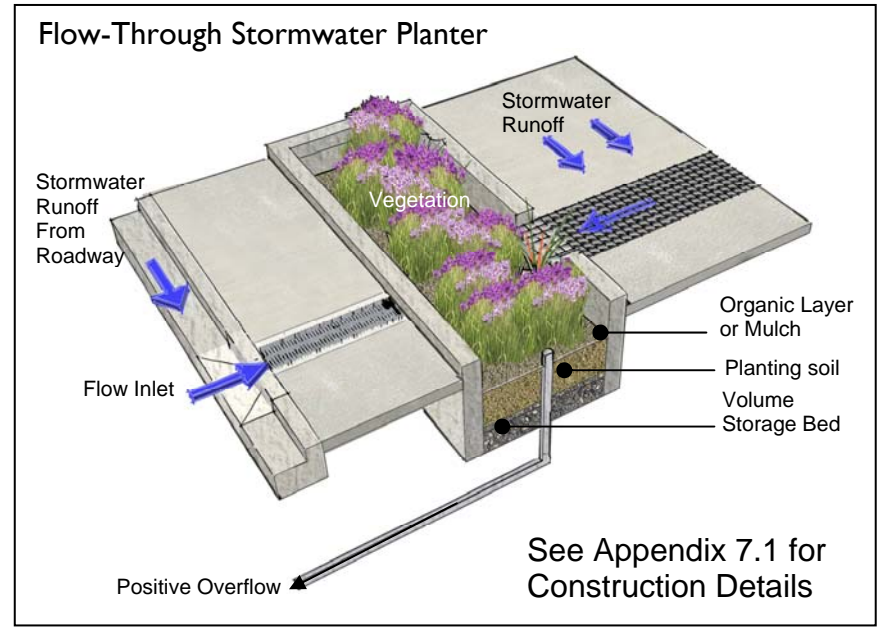



Michigan Avenue rain gardens in planter boxes in Lansing, MI.
Source: Tetra Tech



Cultural Trail Indianapolis: Median Stormwater Planter
Photo Credit: indyculturaltrail.org/blog/tag/green-street/



Street view of rain gardens in planter boxes in Lansing, MI.
Source: Tetra Tech



Sidewalk Stormwater Planter
Photo Credit: www.tavelladesigngroup.com

Rain Gardens

Rain Gardens are stormwater management facilities for storage and infiltration of relatively small volumes of stormwater. Rain Gardens are not well suited to highly urban conditions, but they are useful in residential settings and even more dense residential complex developments. A Rain Garden is established by creating a depression or shallow pond which receives rainwater from adjacent streets, sidewalks, parking lots and roofs. The depression is planted with flood tolerant vegetation which contributes to filtering pollutants from stormwater runoff. Water which infiltrates the planting soil is also filtered and in some cases stored to reduce peak flows. Positive overflow systems are installed to prevent flooding around the garden during larger storm events. Rain Gardens, like other bioretention facilities are best suited for areas with infiltration rates of more than 0.25 inches per hour.

- When considering infiltration type stormwater management facilities always perform the appropriate soil infiltration tests.
- Refer to the *LID Manual for Michigan*, Appendix E “Soil Infiltration Testing Protocol”.
- For Brownfields properties, refer to pages 7 and 8 of this document, however, Rain Gardens are not generally recommended for sites with contaminated soils.

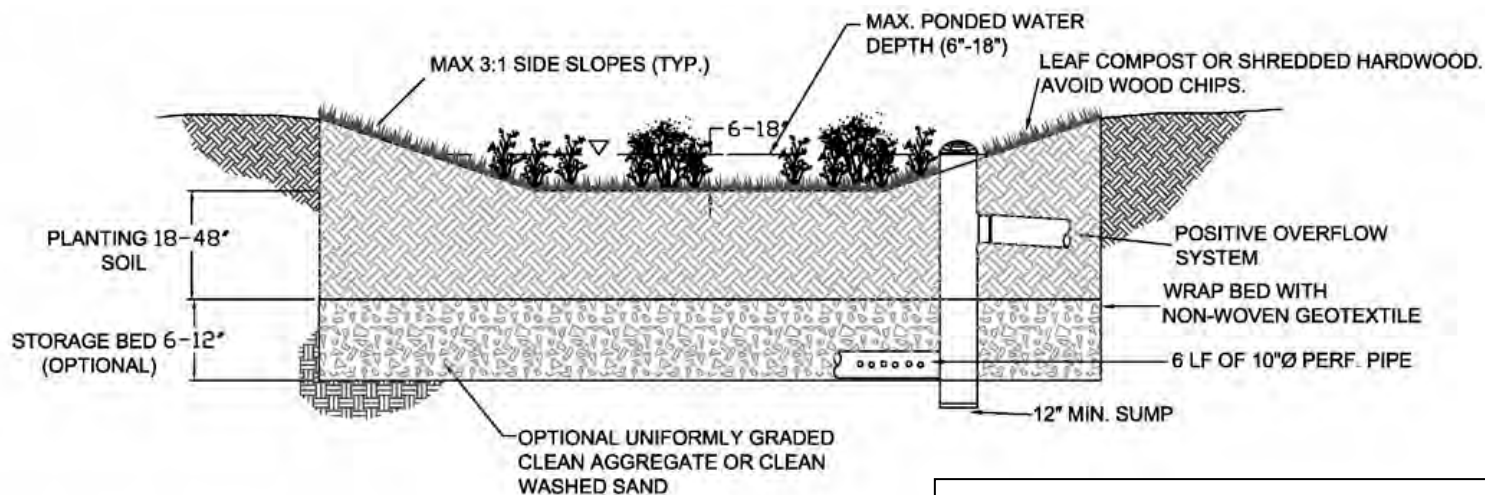

Source: Prince George’s County Bioretention Manual with modifications by Cahill Associates, 2004

3.3.3. Bio-Filtration Facilities

Bio-Filtration is a system which uses living material to capture and/ degrade pollutants carried by stormwater runoff. These facilities are often used to improve stormwater quality before it enters retention or infiltration facilities. Bio-filtration facilities are particularly useful for streetscaping as pre-treatment for pollution and are typically most useful adjacent to streets. The physical design is narrow and linear allowing them to fit in medians or street right-of-way spaces. Bio-filtration facilities include grass filter strips which are gently sloped grassy areas typically used to treat sheet flow and vegetated swales or “Bioswales” which are described below.

Bioswales

Bioswales are the Bio-filtration Facilities best suited to streetscape design. They are designed as long, shallow earthen channels planted with native wildflowers, grasses, shrubs and trees designed to slow, filter and infiltrate stormwater runoff. As stormwater flows slowly along the swale, plants take up various pollutants while still more water is filtered as it infiltrates through the soil. Swales should be between 200 and 250’ long in order to retain water long enough to allow filtration to occur. Underdrains placed below the planting soil prevent standing water from occurring. Bioswales can be stand alone stormwater facilities or pretreatment devices for stormwater being conveyed to larger downstream facilities.

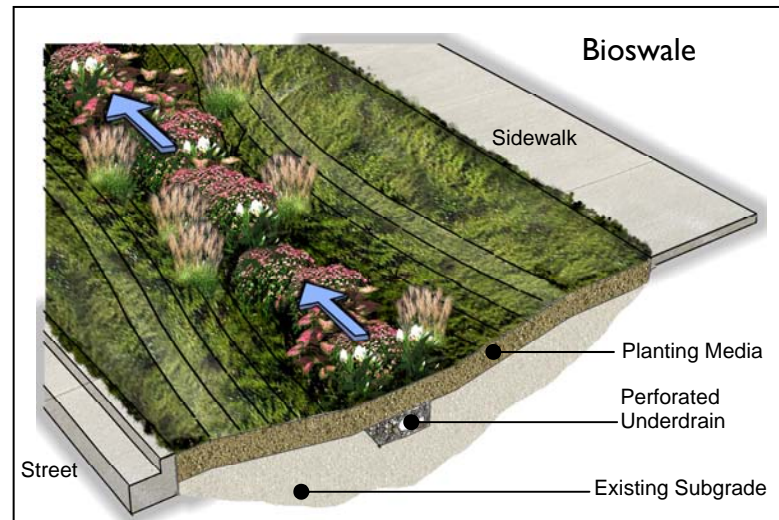

See Appendix 7.1 for Construction Details



Photo Credit: www.glencoe.pps.k12.or.us

3.4. Landscaping



Trees and plantings are critical elements of streetscape design. Trees define a street and separate traffic from pedestrians. Their canopies can give streets a “ceiling”, scaling down what might otherwise be overpowering environments. Trees soften harsh urban environments and can improve spaces where the architecture has little to offer. Street landscaping ensures that people remain connected to nature despite the urban setting. The many environmental benefits to street trees and plantings were discussed earlier in this study and are summarized below.

Green Objectives

- Positively influence localized climate (shade from summer sun and shelter from winter winds).
- Remove air pollutants.
- Increase animal habitat.
- Reduce stormwater runoff.
- Reduce heat and associated energy use for cooling.
- Encourage use by improving the pedestrian environment.



Photo credit: www.cnr.vt.edu/urbanforestry



Photo credit: www.fs.fed.us

3.4.1. Street Trees and Structural Soils

Streets are extremely harsh environments for trees. According to the American Forestry Association the average life of a downtown street tree is only 13 years. Air pollution, compacted soils, drought conditions, contaminated water, lack of root space and many other factors all contribute to this statistic. In light of the poor environmental conditions in which street trees exist it is vital to tree health that they are planted where proper root structure can develop in soil with adequate water, nutrients and oxygen. Street trees are typically planted in sidewalks or narrow medians where roots quickly encounter adverse soil conditions as they attempt to spread under the paved surfaces. “Structural Soils” are an engineered growing medium designed to address soil compaction and a lack of useable soil volume where trees are planted in pavement. In street tree plantings, structural soils ideally extend from the curb to the building face under the entire pedestrian zone to allow for tree roots to extend as far as possible. The composition of the structural soil ensures that even under heavily used pavements it never becomes so compacted that roots cannot grow into the pore spaces. Structural soil can be expensive; however, it is a relatively small price to pay for tree longevity and the added insurance that trees will reach maturity and the ultimate vision of the streetscape design is realized.

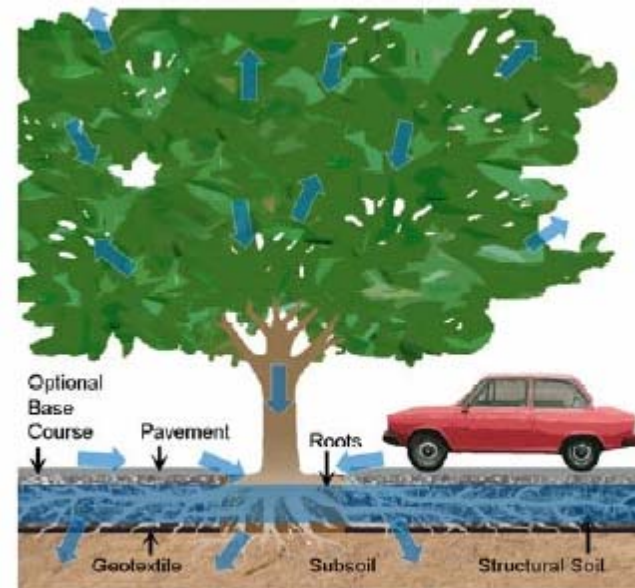

Management Practice for Sustainable Urban Sites

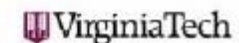

See Appendix 7.1 for Construction Details

3.5. Furniture and Fixtures



Site Furniture and Fixtures such as street lights or bollards can enhance the pedestrian environment by providing rest, convenience, utility and safety. They are specified for most streetscapes however it is important that designers choose site furniture and fixtures which meet their overall “Green” streetscape objectives.

Green Objectives

- Create comfortable outdoor spaces which encourage people to walk rather than drive.
- Reduce light pollution while maintaining a safe pedestrian environment.
- Use locally produced, recycled and/or renewable materials and energy efficient products wherever possible.

Furniture Siting Guidelines

1. Place appropriate furniture according to the requirements of a particular space. For example, provide seating and a trash bin near a coffee shop.
2. Locate sitting areas to take advantage of winter sun and Summer shade.
3. Group street furniture to create a sense of place at potential gathering points.
4. Furniture siting should consider the local demographic. For example, if the local population is elderly try to place benches every 200 feet as resting stops.
5. Place site furniture in its own zone along walkways to maintain an unobstructed walking corridor.
6. Do not place furniture at street corners where it may interfere with sight lines.
7. Select furniture within a product range, having shared design elements which express a holistic design approach.
8. To avoid the appearance of a cluttered streetscape, attempt to create a pattern or rhythm with the furniture elements.
9. Choose sturdy, vandal resistant and sustainable materials.



Photo credit: www.class.uidaho.edu/.../sidewalks.htm

3.5.1. Outdoor Lighting

Well designed outdoor lighting will contribute to creating green streets and neighborhoods and enhance safety and security. Careful design can reduce negative environmental impacts of outdoor lighting by:

- reducing energy use by focusing lighting to where it is needed;
- reducing energy use by utilizing energy efficient luminaires such as LED or solar powered street lights;
- reducing energy use by utilizing light network control systems which eliminate unnecessary light operation;
- minimizing obtrusive light, also known as glare, which can cause annoyance, discomfort or loss of visual ability for pedestrians and drivers and intrude into interior living spaces;
- minimizing light spillage onto adjacent properties or into residences;
- minimizing the upward casting of light into the night sky that in many cities has blotted out all but the brightest stars.

Design elements that meet the objective of providing safety and security, while minimizing impacts, include:

- shielded luminaires that protect pedestrians and motorists from obtrusive light;
- high cut-off fixture designs that minimize light spillage by directing light only to where it is needed;

- fully shielded fixtures that eliminate the upward cast of light into the sky above the fixture.

Integrating these elements into the design of outdoor lighting will provide the sense of security that urban resident's desire. At the same time they will create a more attractive nighttime living environment for pedestrians, drivers and residents by reducing the negative impacts of light pollution.



Photo credit: www.inhabitat.com

Cutoff lighting limits light pollution of the sky and directs light only where it's needed.

3.6. Bicycle Facilities

Designing green streets includes identifying needs and accommodating bicycles just as for other vehicles in the traffic mix. Streets should be designed and constructed to safely accommodate known and anticipated bicycle traffic and encourage bicycle use. The fundamental needs of bicyclists are twofold: safety while moving in traffic and convenient, safe and secure parking.

All streets on which bicycles are permitted to operate should be designed and maintained to accommodate shared use by bicycles and motor vehicles. On most urban streets safety while moving in traffic can be accomplished with wide lanes (4.5M/14.67ft) or with dedicated bike lanes on higher volume, higher speed arterials.

Integrating signs and pavement markings for bicycle facilities into the design of the street can encourage increased bicycle use. Signs and pavement markings can improve traffic operations as well as increase safety by alerting drivers to the presence of bicycles. This helps legitimize the presence of bicycles in the eyes of motorists, and encourage bicycle use.

Conveniently located, safe and secure parking should be provided as part of an overall traffic plan and street design. Integrating an adequate number of appropriately designed bike racks within or adjacent to other transportation facilities, such as parking garages and bus stops, is a cost effective approach.

Bicycle racks under cover, for instance within a parking structure, will encourage bicycling in inclement weather as well as good weather.

Critical to promoting safe bicycling is ensuring that bike lanes and street gutters are clear of debris. Loose stone, deicing sand and grit, litter and debris from passing traffic can be a major hazard to bicyclists moving in traffic. Failed pavement and sunken storm grates can also create hazards to bicyclists.



4. Applying the Guidelines

The table below provides a crosswalk of the design objectives discussed in Chapter 2 and the Streetscape elements presented in Chapter 3. The chart is a simple tool for identifying combinations of streetscape elements which will ensure that all 7 Green Streetscape Design Objectives are met.

	7 Green Streetscape Design Objectives						
	Improve Air Quality	Reduce Heat Island Effects	Improve Water Quality/Efficiency	Improve Energy Efficiency	Enhance the Urban Forest & Wildlife Habitat	Reduce Light Pollution	Mitigate/Rehabilitate Brownfield Conditions
Porous Paving		✓	✓				
Light colored Paving	✓	✓					
Landscaping	✓	✓			✓		
Planters	✓	✓			✓		
Bicycle Rack	✓						
Stormwater Planters	✓	✓	✓		✓		
Bio-Swale		✓	✓		✓		✓
Constructed Filters			✓				
Rain Gardens		✓	✓		✓		
Recycling Bins				✓			
Street Trees	✓	✓		✓	✓	✓	
Continuous Planting Strips	✓				✓		✓
Cut-off lighting				✓		✓	
Narrow Lanes	✓	✓					
Bicycle Lanes	✓			✓			

5. Oakman Boulevard “Green” Streetscape Concept

This Chapter presents a conceptual streetscape design for adjacent redevelopment sites along Oakman Blvd in Detroit, MI. The design is intended to illustrate the feasibility of meeting the 7 “Green” Streetscape objectives previously outlined in this study and provide a roadmap for implementation at this location.

5.1. Site Analysis

The study site includes a half block of Oakman Blvd. at Woodrow Wilson Ave. located in Detroit’s Central Woodward/ North end area. A new pocket park has recently been constructed at the corner of Oakman Blvd. and Woodrow Wilson Ave. providing a much needed open space amenity for the neighborhood. A historic commercial high rise building on the north side of Oakman Blvd. is to be converted to a mixed use building while a three story residential complex is planned for a site on the south side of the street. All new construction proposed for these sites is designed with sustainability in mind and there is an excellent opportunity to extend these “green” design principles to area where the properties meet the street and into the design of the street itself. Oakman Blvd. is an arterial street with a 120’ right of way. The street is configured with two travel lanes in each direction as well as parking lanes on either side of the street and a 5 ½’ wide concrete center median. The high-rise building is set back 21 feet from the existing curb line giving it a dominant street presence and an urban feel at the sidewalk. The residential complex across the street is set back 12 feet with ample room for green-space between the building and street. As mentioned, Oakman Blvd. is an arterial road, therefore a significant amount of utility

infrastructure is also present. The following page provides a plan of the existing underground and overhead utilities.



Aerial View of Oakman Blvd. @ Woodrow Wilson Ave highlighting the areas of new development.

5.2. Existing Conditions

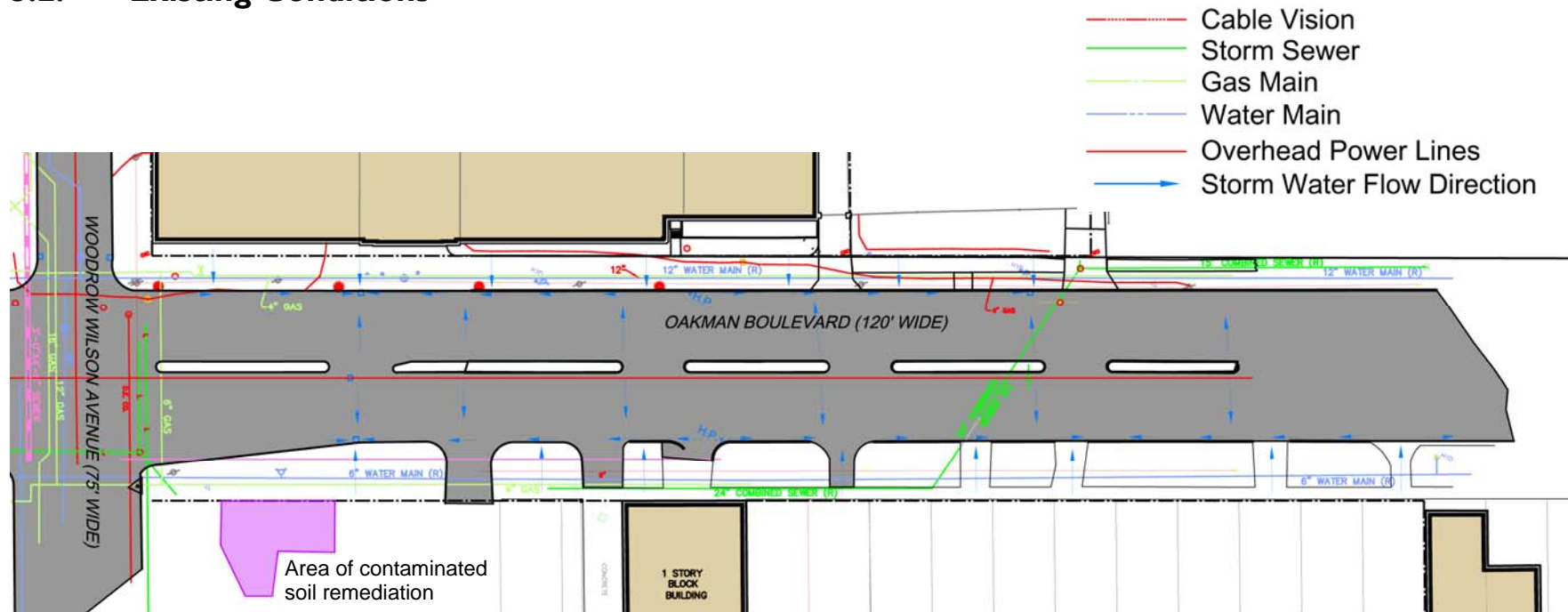

Utility Survey: Observations and Conflicts

- Cable vision and gas lines on the North side of Oakman Blvd. may be shallow buried and could conflict with new stormwater facilities.
- Existing utility poles and hydrants need to be considered in streetscape design.
- Combined sewer lines appear to be deep enough to outlet proposed filtration facilities
- Oakman Blvd. is graded with a center crown, stormwater drains away from the median to the sidewalk curbs.
- The existing conditions plan above shows Oakman Blvd. to have minimal stormwater inlets. The proposed stormwater planters shown in the concept design on the next page would increase the number of stormwater inlets substantially and could alleviate ponding and standing water issues.

5.3. Conceptual Design

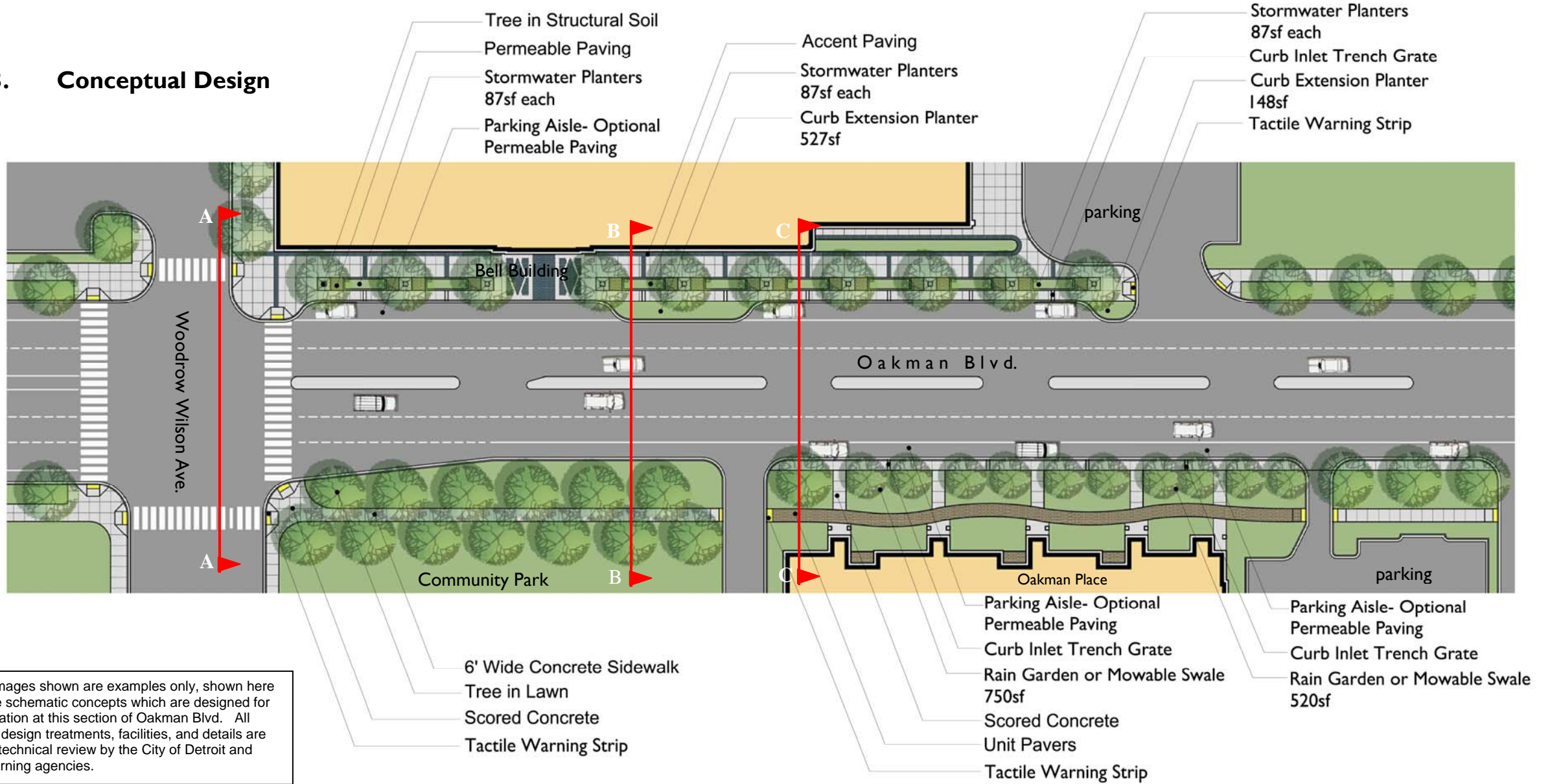

Note: All images shown are examples only, shown here to illustrate schematic concepts which are designed for implementation at this section of Oakman Blvd. All schematic design treatments, facilities, and details are subject to technical review by the City of Detroit and other governing agencies.

Concept Images



North Side of street looking east
Featuring proposed Curb Extension Planter

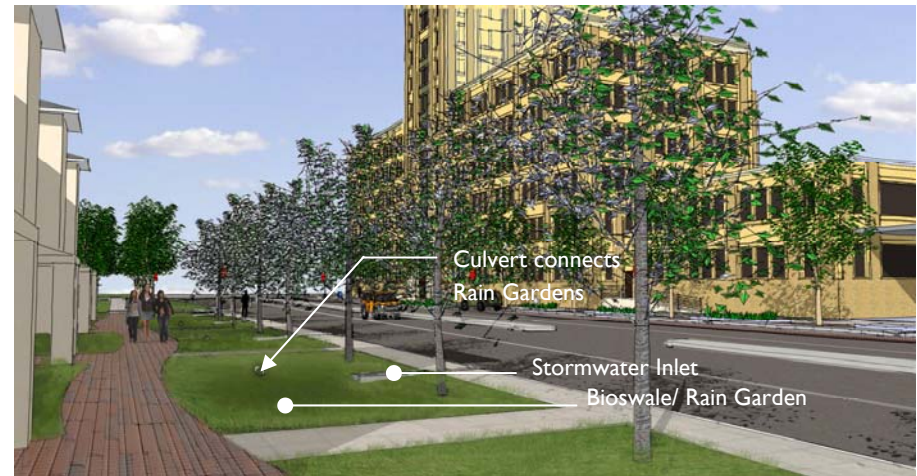

South of street looking west
Featuring proposed Rain Garden/ Swales



North Side of street looking west
Featuring proposed parking lane and Bio-Retention Planters

Stormwater Management Goals

- Flow control and water quality treatment
- Treat all runoff from a 1 year 24 hr. storm for the entire ROW including front yard setbacks. May also treat half the roof runoff from the new condo complex if space permits.
- Infiltrate stormwater wherever possible through the use of permeable paving.
- Maximize evapotranspiration by creating planting areas.
- Create streetscape stormwater management facilities which are landscape features that the community can enjoy or even tend to so that a sense of ownership and neighborhood pride is developed.
- Demonstrate green streetscape techniques to encourage more widespread use.

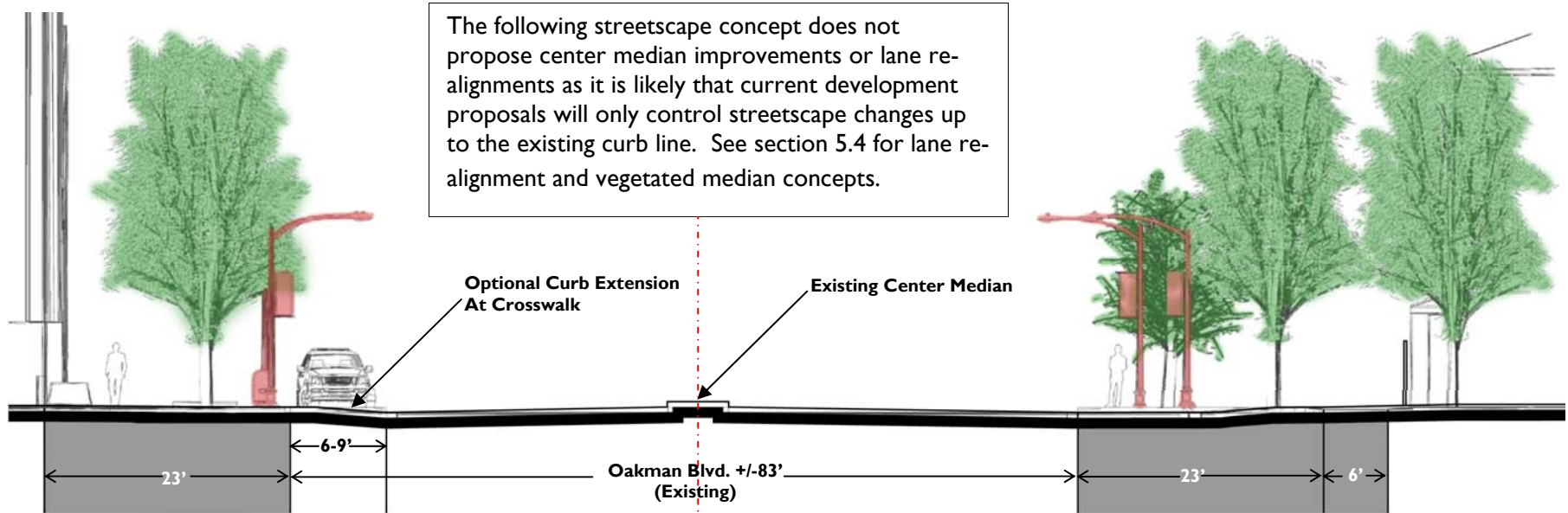

Section A-A

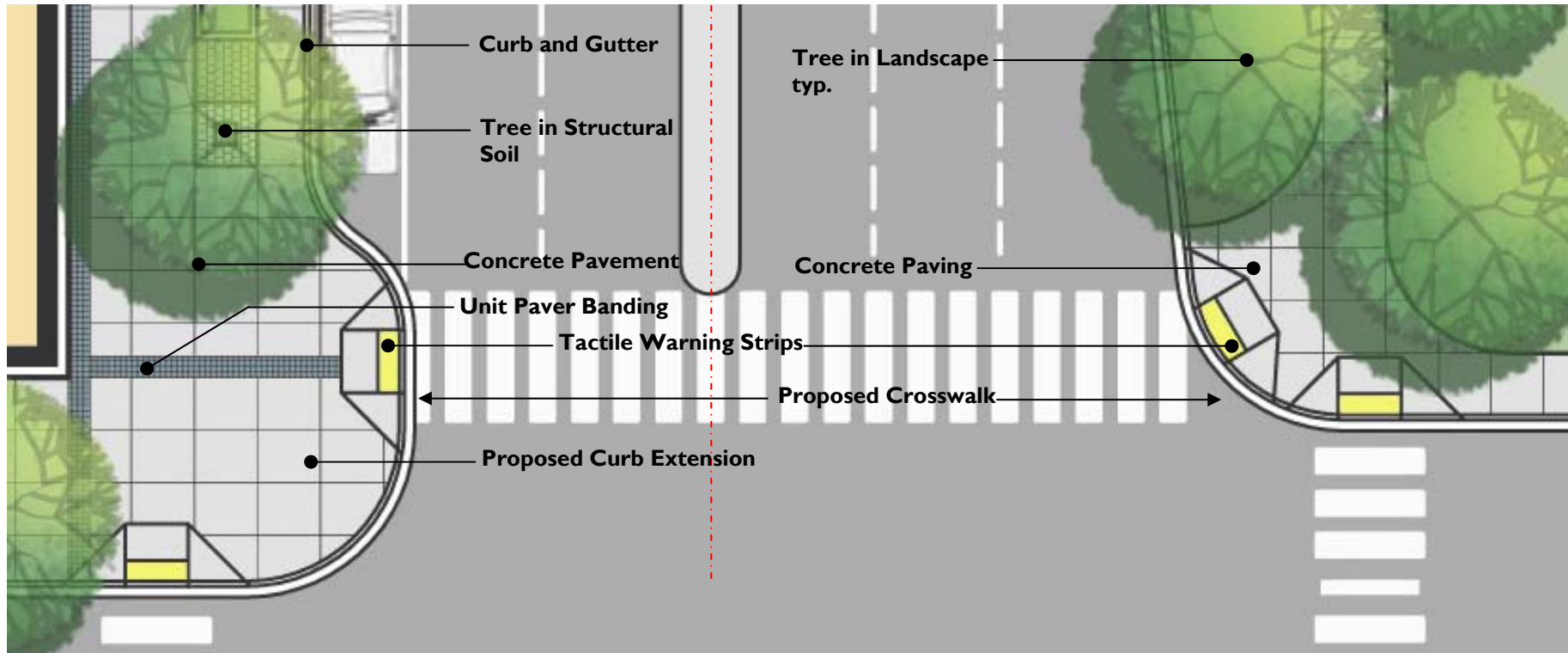

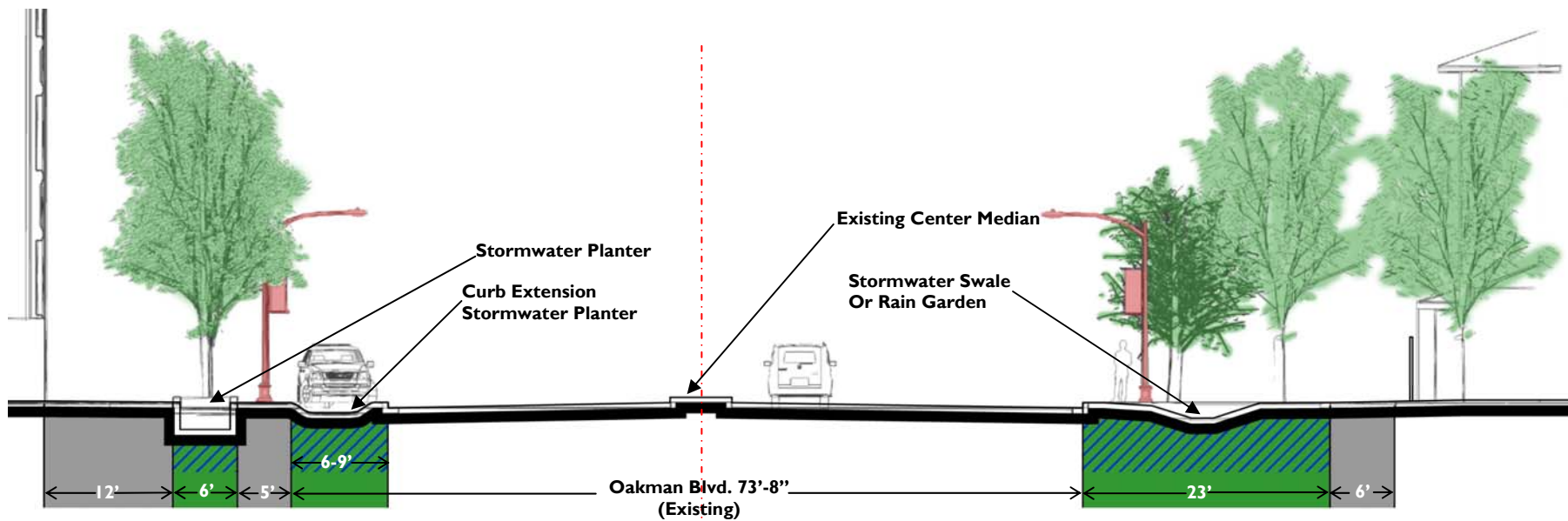

Section B-B

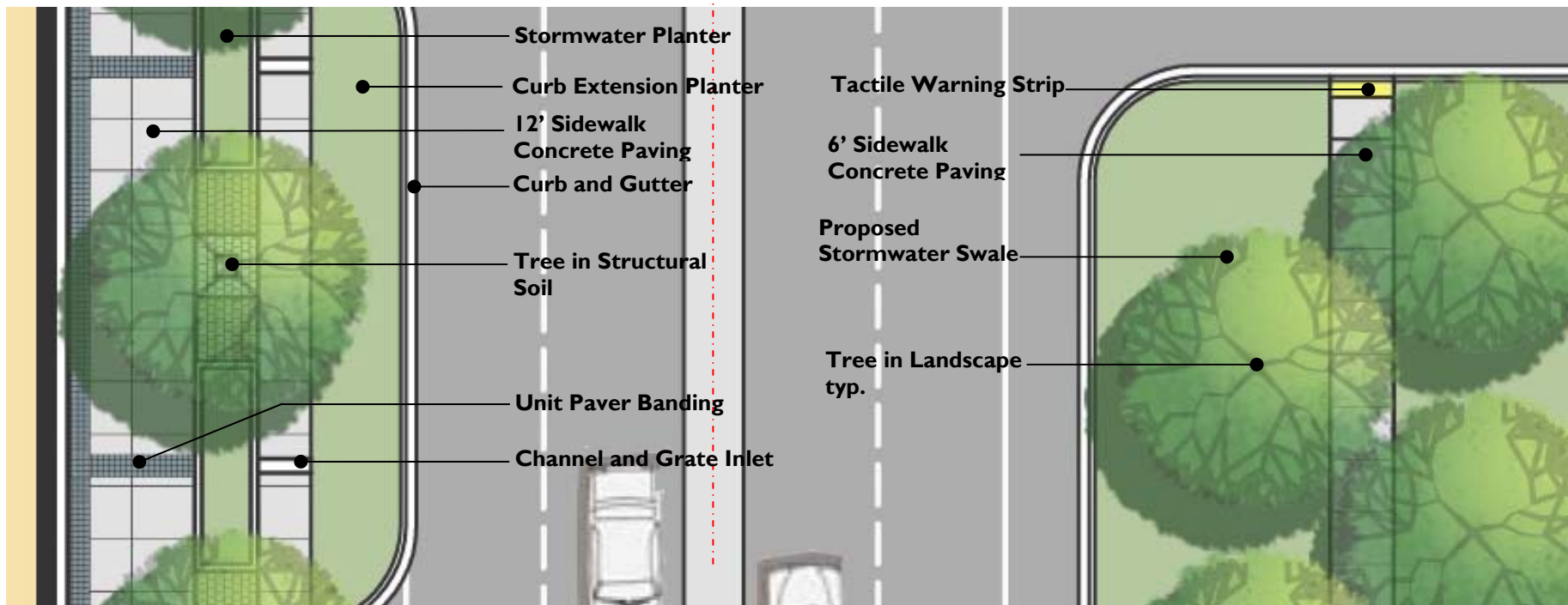

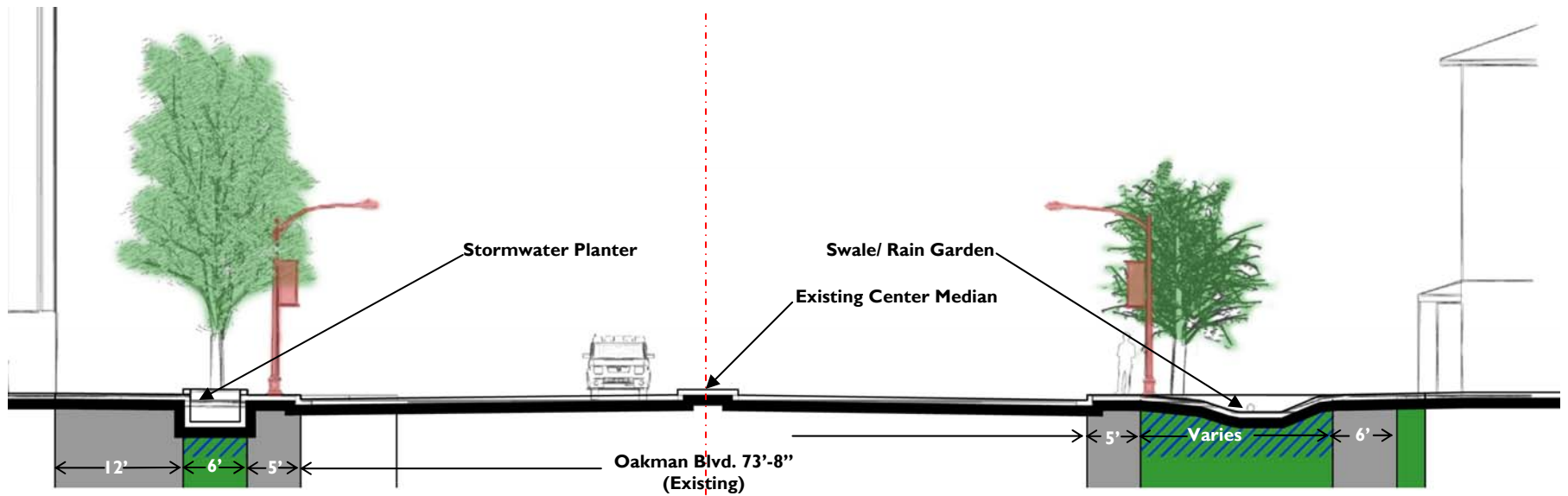

Section C-C

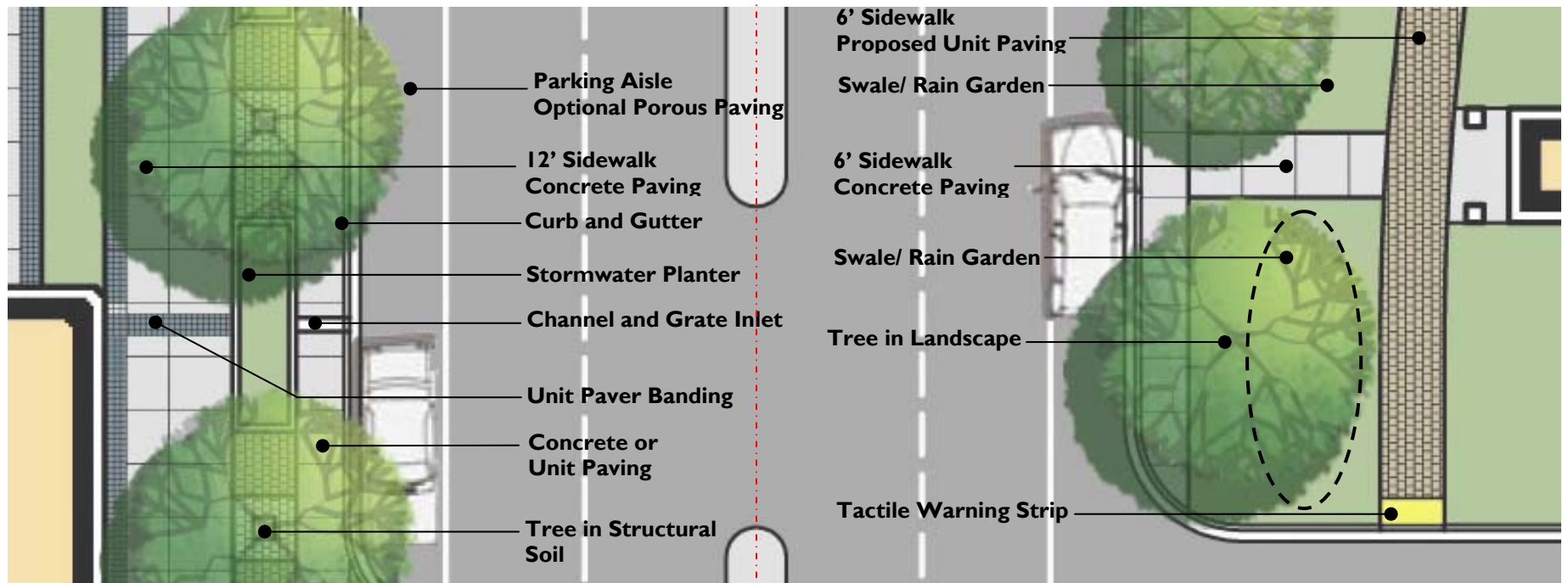

Greening the Center Median

Sustaining vegetation in the middle of a roadway is difficult. Often plants are subjected to higher temperatures in the summer and more road salt in the winter. Where center median planting strips are narrow, plants often experience drought conditions as water typically drains away from the center of the road and is not allowed to infiltrate the planting strip soils. In order to establish successful center median plantings the median must be wide enough to provide an acceptable root zone and offer sufficient surface area so that enough rain water is allowed to infiltrate the root zone.

- It is not recommended that trees be planted in medians less than 8ft wide. Always consult an arborist or landscape architect for proper tree selection.
- Where plantings are proposed for narrow medians irrigation may be required or provisions made for periodic watering during drought conditions.
- Center median planting strips maybe designed as rain gardens where designers control grades for the complete street. Lanes may be sloped toward the median so that it receives stormwater runoff. Overflow drains located within the median will convey storm event overflow volume to the municipal storm line.
- Median planters not receiving rainwater runoff from the street and are not irrigated should be planted with hardy, drought and salt tolerant species.



Photo credit: www.co.clark.wa.us/.../kline/line/photos.html

5.4. Future Bike Lanes, Intersection and Median Improvements

Future reconstruction or renovation of Oakman Blvd. may offer an opportunity to improve the Oakman Blvd./ Woodrow Wilson intersection, and modify the street geometry to accommodate bike lanes, narrow travel lanes, and/or a wide vegetated center median. These modifications would contribute to meeting the 7 “Green” Streetscape Design Objectives and are important to achieving a more complete streetscape design. All three of the following concepts offer ideas for accommodating bike lanes and intersection crosswalk improvements but vary in the degree to which travel lane widths are decreased to accommodate a wider center median. Where traffic volumes permit, the design goal should be to reduce impervious surfaces and increase opportunities for alternative transportation.

Concept I



- Existing curb locations remain the same.
- Number of traffic lanes remain the same.
- Space for 6’ wide dedicated bike lanes is created by narrowing the existing center median to 20”.

Crosswalk:

- 10’ wide “Continental” style painted bars.

Concept 2 – Vegetated Median



- Number of travel lanes are reduced from 2 in each direction to 1 in each direction with left turn only lanes where required.
- Eliminating the 2 travel lanes creates space for dedicated bike lanes in both directions as well as a 9' wide landscaped center median which widens to 20' where left turn lanes are not required.
- The landscaped center median creates space for street trees which will dramatically increase the canopy cover over Oakman Blvd.
- Concept achieves 12% less impervious surface than the existing condition.

Crosswalk:

- Highly visible Streetprint®: Stamped colored asphalt
- Optional center median pedestrian refuge
- Crosswalks shown 14' wide, 10' wide colored walk with 2' wide white bands on either side

Concept 3 – Vegetated Median with Dedicated Bike Path



- <8 Parking Aisle
- <12 Drive Lane
- <10 Bikeway
- <12 Drive Lane
- <8 Parking Aisle

- The number of travel lanes is reduced from 2 in each direction to 1 in each direction and left turns are only provided at block end intersections.
- Eliminating the 2 travel lanes creates space for a separated 2-way bikeway in the center median flanked by 10' wide landscape strips on either side.
- The linear landscape strips may also be designed as bio-swales for filtering and infiltrating stormwater runoff from Oakman Blvd.
- This concept requires 30% less impervious surface than the existing condition.

Crosswalk:

- Durable, scored Colored Concrete
- Center Median pedestrian refuge
- Crosswalks shown 14' wide, 10' Wide Concrete walk with 2' Wide White bands on either side



Baltimore MD: center median bikeway

5.5. Crosswalk Design

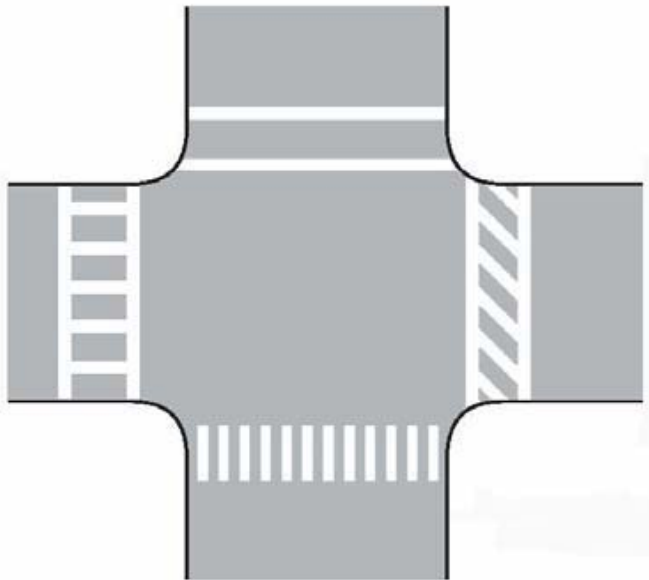

Typical standards require that crosswalks be composed of solid white lines, 6 to 24" wide. The width of the crosswalk should be a minimum of 6". The city of Detroit or Michigan Department of Transportation will dictate local crosswalk standards. The following layouts are most commonly used for crosswalks:

- Standard (top)
- Ladder (left)
- Diagonal Ladder (right)
- Continental (bottom)

Standard/ Infill Crosswalk

The most common crosswalk layout, the standard, or transverse, layout consists of markings which are perpendicular to the roadway, spaced at least 6 feet apart (including the width of the lines), and are commonly 12 inches wide. The standard layout is widely used because it requires the least number of pavement markings; however, it is also the least visible to drivers. Therefore, it is best used at signalized intersections. To make the standard crosswalk more visible the space between the painted lines can be enhanced by adding a color coating and/or a stamped texture to the asphalt surface. The following page presents examples of additional paving materials which can also be used to infill the crosswalk for high visibility and enhanced aesthetics. Where cost or construction time make the infill type crosswalk impractical, a continental style painted crosswalk may be preferable. It offers high visibility, easy installation and low cost.

Paint/Coating Types

- Epoxy Resin
- Thermoplastics
- Inlay Tape

The following page provides examples of innovative crosswalk options.

Crosswalk Materials



Scored concrete crosswalk



Brick Paver crosswalk



Streetprint: Color Coated and Stamped Asphalt



Colored Concrete crosswalk with brick paver edge



Streetprint: Thermoplastic patterned crosswalk in asphalt

Infill Paving Materials
Brick
Imprinted Asphalt
Concrete – Pattern, Colored

6. Appendix

6.1. Construction Details

Table of Contents

Pervious Paver and Asphalt Sections.....	PV100
Movable Swale/ Basin.....	SW200
Bioswale	SW201
Stormwater Planter: Overflow Design.....	SW202
(Contaminated Soils)	
Facility Overflow Configurations.....	SW203
Curb Extension SW Planter: Overflow Design.....	SW204
Curb Extension SW Planter Section: Overflow Design.....	SW205
Curb Extension SW Planter: Flow Through Design.....	SW206
Curb Extension SW Planter Section: Flow Through Design.....	SW207
Curb Extension SW Planter Inlet/Outlet Details.....	SW208
Filtration Swale Section: Adjacent to Road.....	SW209
SW Planter: Flow Through Design with Parking.....	SW210
SW Planter Section: Flow Through Design.....	SW211
SW Planter Plan: Overflow Design with Parking.....	SW212
SW Planter Section: Overflow Design with Parking.....	SW213
Concrete Inlet: For Local Service Streets.....	SW214
Concrete Inlet: For Collectors.....	SW215
Concrete Inlet: For Collectors.....	SW216
Concrete Inlet: Channel & Grate type.....	SW217
Growing Medium Profile and Check Dam.....	SW218
Street Tree Planting in Structural Soil.....	L300

All details have been adapted for site specific use in Detroit MI. Several conceptual detail designs are by Portland Bureau of Environmental Services Stormwater Facility Handbook, City of Portland, Oregon.

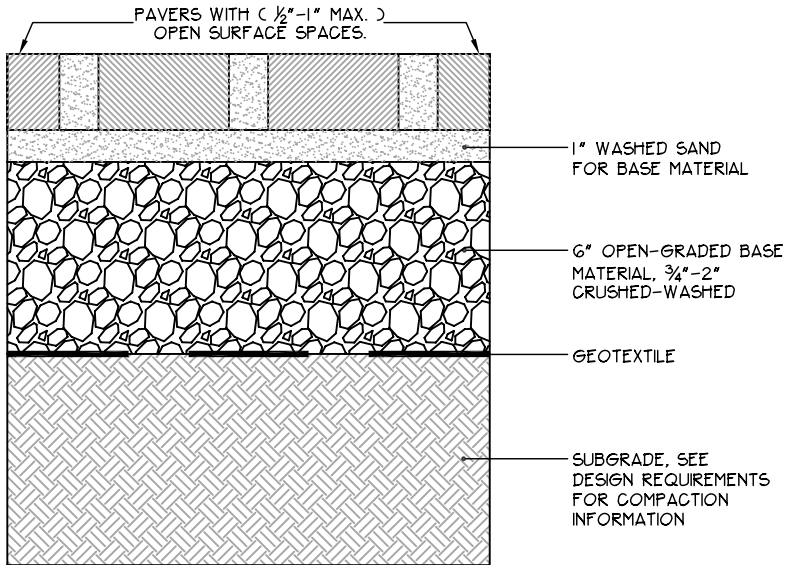

PERMEABLE CONCRETE BLOCK OR "PAVER" SYSTEMS

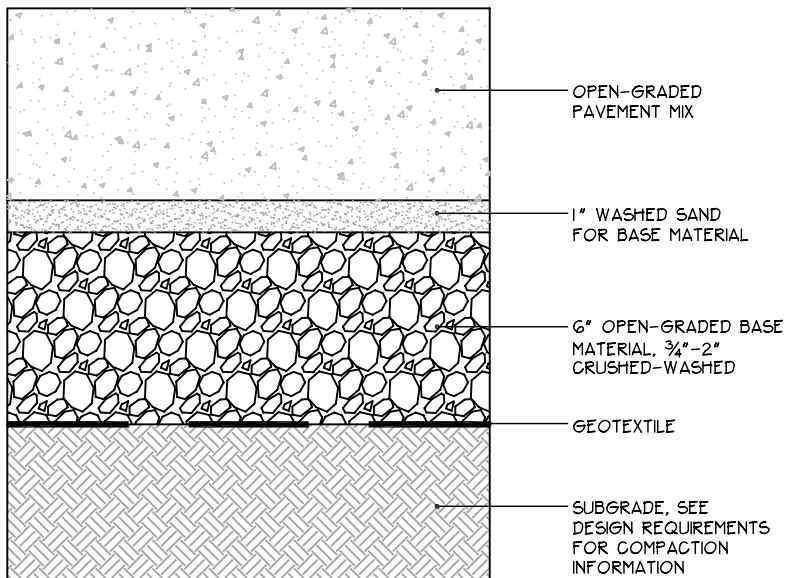

PERVIOUS (OPEN GRADED) CONCRETE AND ASPHALT SYSTEMS

	RESIDENTIAL DRIVEWAY OR PEDESTRIAN ONLY	PRIVATE STREET, PARKING LOT, OR FIRE LANE	PUBLIC STREET
PREVIOUS CONCRETE	4"	4"	7"
PREVIOUS ASPHALT	2 1/2"	3"	6"
PERMEABLE PAVERS	2 3/8"	3 1/8"	3 1/8"
ENGINEERING REQUIRED	NO	YES	YES
COMPACTION REQUIRED	NO	YES	95%

EXHIBIT 2-8
 PERVIOUS PAVEMENT REQUIREMENTS FOR TOP LIFT DEPTH, ENGINEERING, AND COMPACTION.

N.T.S.

			Proj. No.:
			Date:
	Rev.:	Date:	Drawn By:
Green Streetscape Study			Drawing No.:
Oakman Blvd. Detroit, Michigan			
Pervious Paver & Asphalt Sections			
			PV100

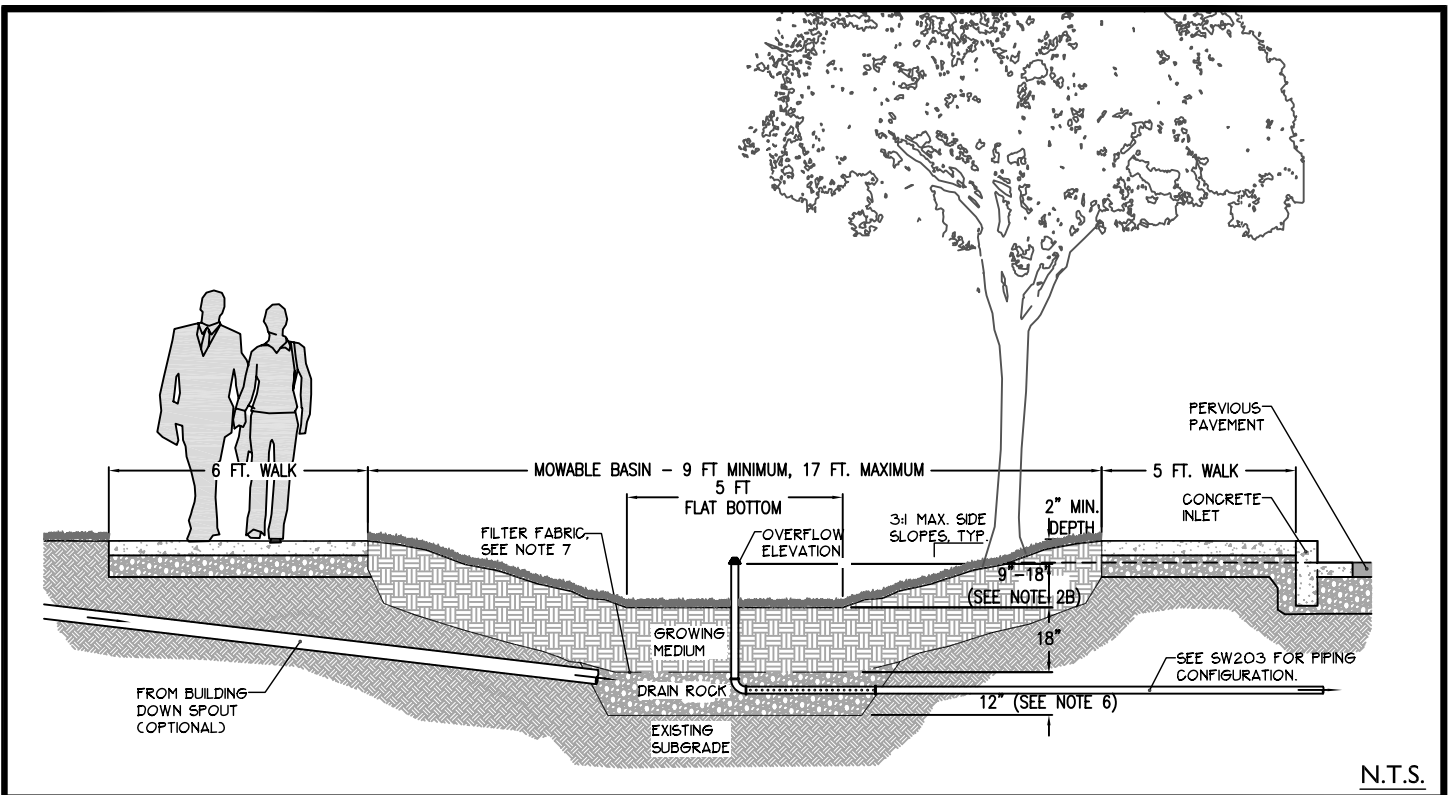

N.T.S.

1. PROVIDE PROTECTION FROM ALL VEHICLE TRAFFIC, EQUIPMENT STAGING, AND FOOT TRAFFIC IN PROPOSED INFILTRATION AREAS PRIOR TO, DURING, AND AFTER CONSTRUCTION.

2. DIMENSIONS:

- a. WIDTH OF BASIN: 9' MINIMUM.
- b. DEPTH OF BASIN (FROM TOP OF GROWING MEDIUM TO OVERFLOW ELEVATION): 12" OR AS DESIGNED BY ENGINEER, 18" MAX.
- c. FLAT BOTTOM WIDTH: 4' MIN.
- d. SIDE SLOPES OF BASIN: 3:1 MAXIMUM.

3. SETBACKS (FROM MIDPOINT OF FACILITY):

- a. INFILTRATION BASINS MUST BE 10' FROM FOUNDATIONS AND 5' FROM PROPERTY LINES.
- b. FLOW-THROUGH SWALES MUST BE LINED WITH CONNECTION TO APPROVED DISCHARGE POINT.

4. OVERFLOW:

- a. INLET ELEVATION MUST ALLOW FOR 2" OF FREEBOARD, MINIMUM.
- b. PROTECT FROM DEBRIS AND SEDIMENT WITH STRAINER OR GRATE.

5. PIPING: SHALL BE ABS SCH.40, CAST IRON, OR PVC SCH.40. 3" PIPE REQUIRED FOR UP TO 1,500 SQ FT OF IMPERVIOUS AREA, OTHERWISE 4" MIN. PIPING MUST HAVE 1% GRADE AND FOLLOW THE UNIFORM PLUMBING CODE.

6. DRAIN ROCK:

- a. SIZE FOR INFILTRATION BASIN: 1 1/2" - 3/4" WASHED
- b. SIZE FOR FLOW-THROUGH BASIN: 3/4" WASHED
- c. DEPTH: 12"-48" BASED ON DESIGNED STORAGE.

7. SEPARATION BETWEEN DRAIN ROCK AND GROWING MEDIUM: USE FILTER FABRIC OR A GRAVEL LENS (3/4 - 1/2 INCH WASHED, CRUSHED ROCK 2 TO 3 INCHES DEEP).

8. GROWING MEDIUM:

- a. 18" MINIMUM
- b. SEE APPENDIX SECTION 6.2 FOR SPECIFICATION OR USE SAND/LOAM/COMPOST 3-WAY MIX.

9. VEGETATION: FOLLOW LANDSCAPE PLANS OTHERWISE REFER TO PLANT LIST IN APPENDIX SECTION 6.3. MINIMUM CONTAINER SIZE IS 1 GALLON. # OF PLANTINGS PER 100SF OF FACILITY AREA):

- a. ZONE A (WET):
 - b. ZONE B (MODERATE TO DRY):
- THE DELINEATION BETWEEN ZONE A AND B SHALL BE EITHER AT THE OUTLET ELEVATION OR THE CHECK DAM ELEVATION, WHICHEVER IS LOWEST.

10. INSTALL WASHED PEA GRAVEL OR RIVER ROCK TO TRANSITION FROM INLETS AND SPLASH PAD TO GROWING MEDIUM.

			Proj. No.:
			Date:
	Rev.:	Date:	Drawn By:
Green Streetscape Study			Drawing No.:
Oakman Blvd. Detroit, Michigan			
Mowable Swale/Basin			
			SW200

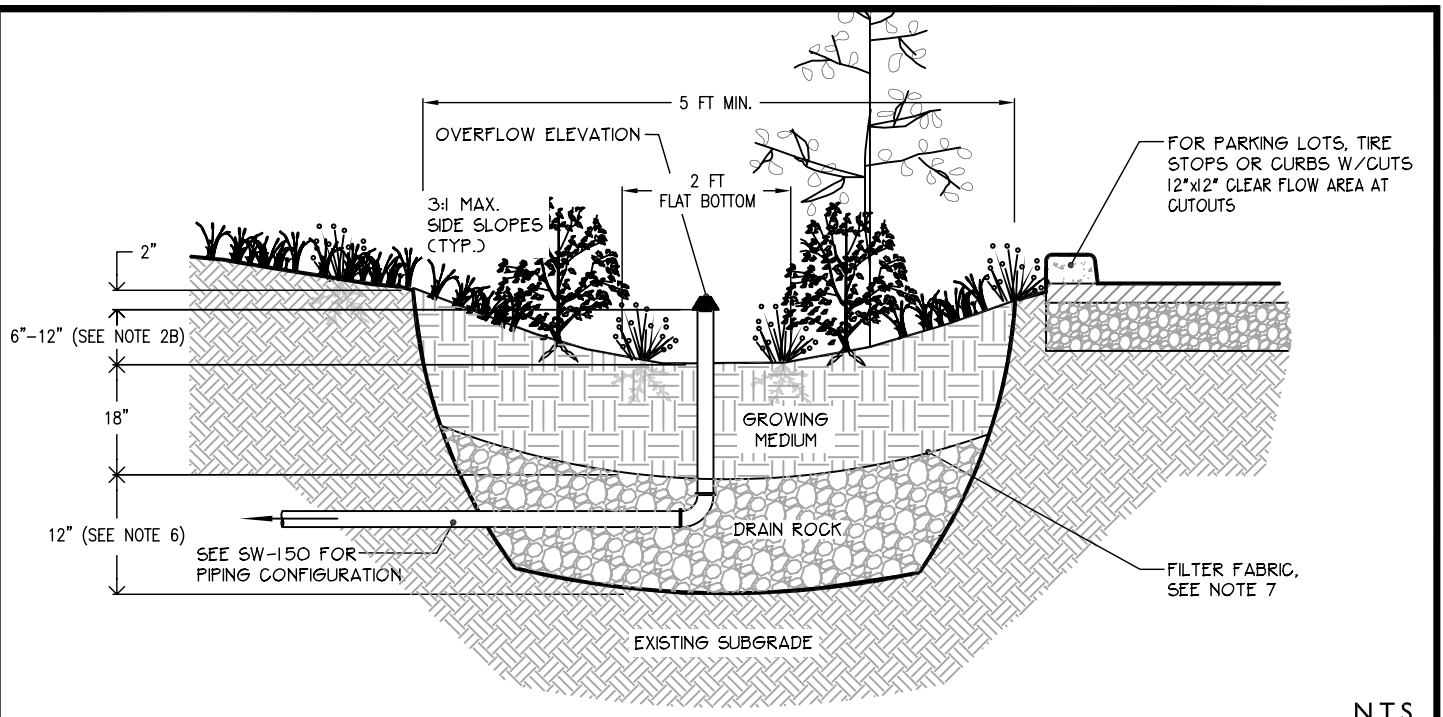

N.T.S.

1. PROVIDE PROTECTION FROM ALL VEHICLE TRAFFIC, EQUIPMENT STAGING, AND FOOT TRAFFIC IN PROPOSED INFILTRATION AREAS PRIOR TO, DURING, AND AFTER CONSTRUCTION.
2. DIMENSIONS:
 - a. WIDTH OF SWALE: 5' - 12'.
 - b. DEPTH OF SWALE (FROM TOP OF GROWING MEDIUM TO OVERFLOW ELEVATION): 9", OR AS SPECIFIED BY ENGINEER - 12" MAX.
 - c. LONGITUDINAL SLOPE OF SWALE: 6.0% OR LESS.
 - d. FLAT BOTTOM WIDTH: 2'.
 - e. SIDE SLOPES OF SWALE: 3:1 MAXIMUM.
3. SETBACKS (FROM CENTERLINE OF FACILITY):
 - a. INFILTRATION SWALES MUST BE 10' FROM FOUNDATIONS AND 5' FROM PROPERTY LINES.
FLOW-THROUGH SWALES MUST BE LINED WITH CONNECTION TO APPROVED DISCHARGE POINT.
4. OVERFLOW:
 - a. INLET ELEVATION MUST ALLOW FOR 2" OF FREEBOARD, MINIMUM.
 - b. PROTECT FROM DEBRIS AND SEDIMENT WITH STRAINER OR GRATE.
5. PIPING: SHALL BE ABS SCH.40, CAST IRON, OR PVS SCH.40. 3" PIPE REQUIRED FOR UP TO 1,500 SQ FT OF IMPERVIOUS AREA, OTHERWISE 4" MIN. PIPING MUST HAVE 1% GRADE AND FOLLOW THE UNIFORM PLUMBING CODE.
6. DRAIN ROCK:
 - a. SIZE FOR INFILTRATION SWALE: 1½" - ¾" WASHED
 - b. SIZE FOR FLOW-THROUGH SWALE: ¾" WASHED
 - c. DEPTH: 12"-48" BASED ON DESIGNED STORAGE
7. SEPARATION BETWEEN DRAIN ROCK AND GROWING MEDIUM: USE FILTER FABRIC OR A GRAVEL LENS (¾ - ½ INCH WASHED, CRUSHED ROCK 2 TO 3 INCHES DEEP).
8. GROWING MEDIUM:
 - a. 18" MINIMUM
 - b. SEE APPENDIX SECTION 6.2 FOR SPECIFICATION OR USE SAND/LOAM/COMPOST 3-WAY MIX.
9. VEGETATION: FOLLOW LANDSCAPE PLANS, REFER TO PLANT LIST IN APPENDIX SECTION 6.3. MINIMUM CONTAINER SIZE IS 1 GALLON. # OF PLANTINGS PER 100SF OF FACILITY AREA:
 - a. ZONE A (CWET): 115 HERBACEOUS PLANTS OR 100 HERBACEOUS PLANTS AND 4 SMALL SHRUBS.
 - b. ZONE B (MODERATE TO DRY): 1 TREE AND 3 LARGE SHRUBS / SMALL TREES AND 4 SMALL SHRUBS AND 140 GROUNDCOVER PLANTS.
 THE DELINEATION BETWEEN ZONE A AND B SHALL BE EITHER AT THE OUTLET ELEVATION OR THE CHECK DAM ELEVATION, WHICHEVER IS LOWEST.
10. WATERPROOF LINER: SHALL BE 30 MIL PVC OR EQUIVALENT FOR FLOW-THROUGH FACILITIES.
11. INSTALL WASHED PEA GRAVEL OR RIVER ROCK TO TRANSITION FROM INLETS AND SPLASH PAD TO GROWING MEDIUM.
12. CHECK DAMS: SHALL BE PLACED ACCORDING TO FACILITY DESIGN. REFER TO SW218 FOR PROFILE AND SPACING.

			Proj. No.:
			Date:
	Rev.:	Date:	Drawn By:
Green Streetscape Study			Drawing No.:
Oakman Blvd. Detroit, Michigan			SW201
Bio Swale			

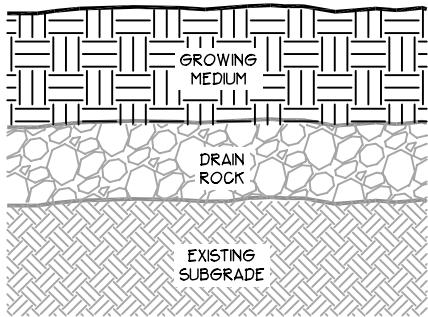

INFILTRATION

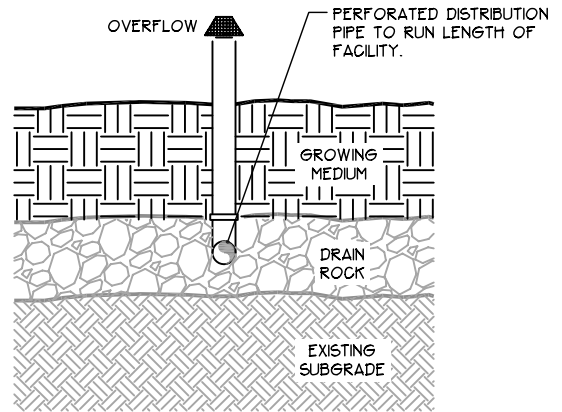

HYBRID

OVERFLOW DIRECTED TO DRAIN ROCK.

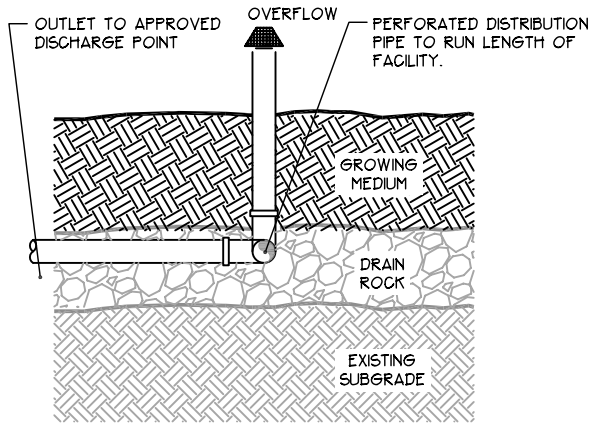

PARTIAL INFILTRATION

OVERFLOW AND UNDERDRAIN REQUIRED. SET UNDERDRAIN WITHIN DRAIN ROCK

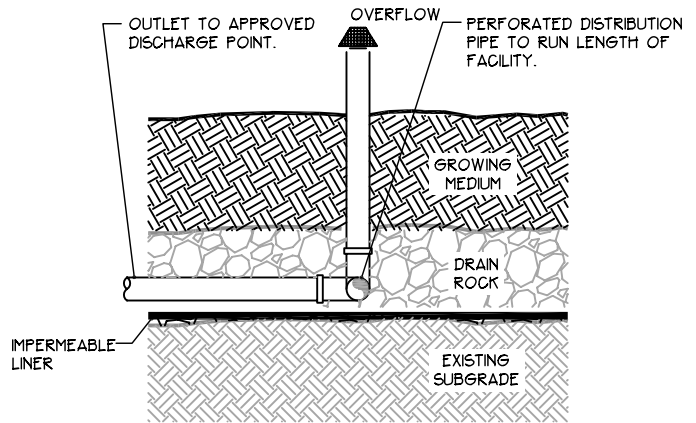

FLOW-THROUGH

OVERFLOW AND UNDERDRAIN REQUIRED. SET UNDERDRAIN AT BASE OF DRAIN ROCK LINER.

NOTE:
OVERFLOW CONFIGURATION AND SYSTEM PIPE SIZING TO BE DESIGNED BY A QUALIFIED ENGINEER AND SUITABLE TO SITE SPECIFIC CONDITIONS.

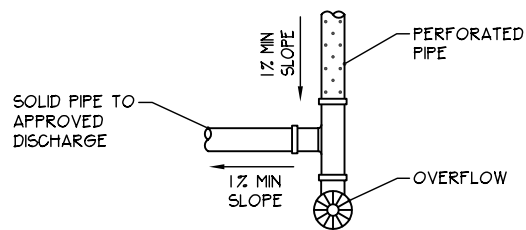

PLAN VIEW

PIPE W/ UNDERDRAIN AND DISCHARGE POINT

N.T.S.

			Proj. No.:
			Date:
			Rev.: Date:
Green Streetscape Study			Drawing No.:
Oakman Blvd. Detroit, Michigan			
Facility Overflow Configurations			

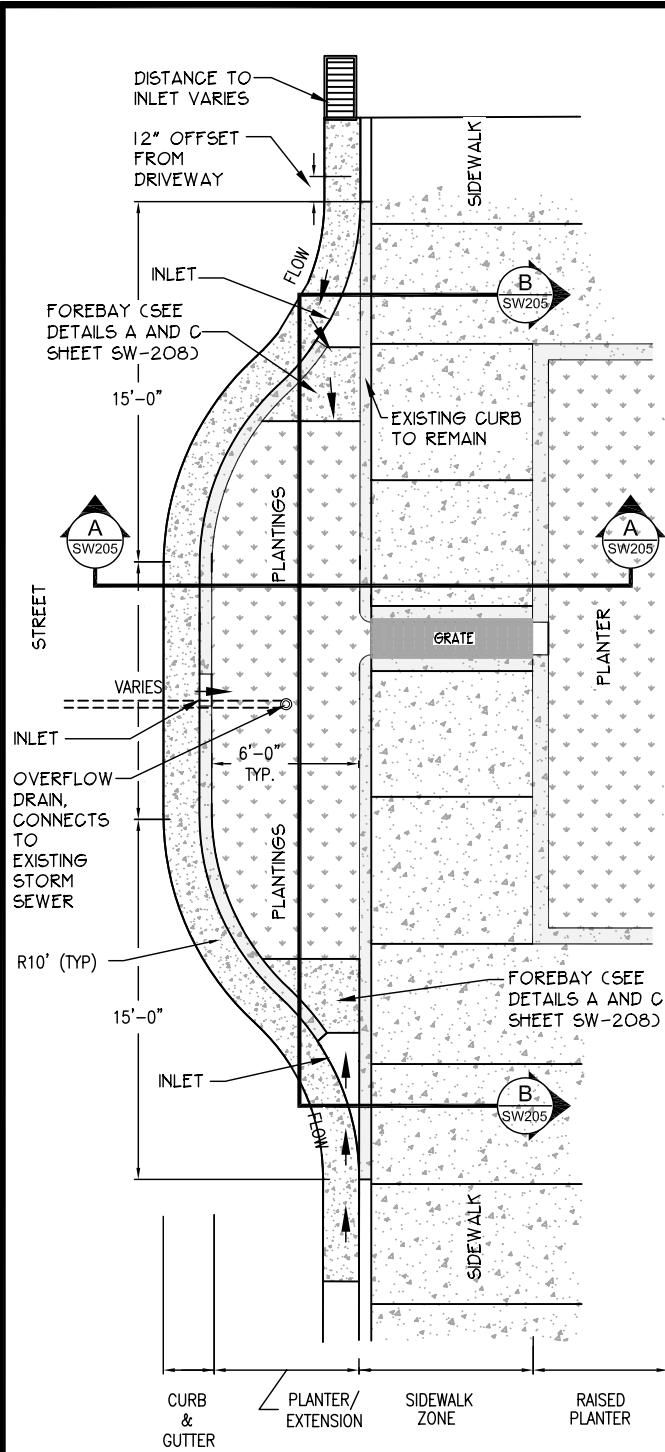

CURB EXTENSION PLAN

NOTES:

1. WIDTH OF CURB EXTENSION: 6' TO 9' TYPICAL FROM INSIDE CURBS. DEPTH OF CURB EXTENSION: 6" MIN. FROM INLET AT GUTTER ELEVATION TO BOTTOM OF FACILITY. ACTUAL WIDTH TO BE DETERMINED BY CITY ENGINEER.
2. LONGITUDINAL SLOPE OF PLANTER MATCHES ROAD: FLAT AS POSSIBLE, 3% MAXIMUM. LONGITUDINAL AND CROSS SLOPE OF SOIL WITHIN PLANTER: NONE, FLAT AS POSSIBLE. TYPICAL CROSS SLOPE OF ROAD 2% TO 6%, CROSS SLOPE OF GUTTER 8%.
3. SPECIAL REQUIREMENTS MAY BE NECESSARY ON STEEP SLOPES AND FOR FACILITIES DESIGNED TO INCLUDE DISCHARGE.
4. INCLUDE BEGINNING AND ENDING STATION ELEVATIONS FOR EACH FACILITY. PROVIDE THE TOP AND BOTTOM ELEVATION OF FACILITY AT EACH STATION SPECIFIED. INCLUDE ELEVATIONS AT EVERY INLET AND OUTLET.
5. SIDEWALK ELEVATION MUST BE SET ABOVE INLET AND OUTLET ELEVATIONS TO ALLOW OVERFLOW TO DRAIN TO STREET BEFORE SIDEWALK.
6. SEE SHEET SW-208 FOR INLET/OUTLET DETAILS.
7. CHECK DAMS REQUIRED: SEE SHEET SW-218 FOR DETAILS.
8. SEE APPENDIX SECTION 6.2 FOR GROWING MEDIUM SPECIFICATIONS.
9. DEPENDING ON LOCATION, UTILITY LINES MAY NEED TO BE SLEEVED.
10. CURB AND GUTTER: MDOT STANDARD ROADWAY DRAWING WITH THICKENED 12" GUTTER. USE 1'-6" WIDE GUTTER.
11. WHERE FEASIBLE, WIDTH OF STORMWATER FACILITY MAY EXTEND INTO EXISTING PLANTING STRIP (IN WHICH CASE EXISTING CURB WOULD BE REMOVED).
12. SEE PLANT LISTS IN APPENDIX SECTION 6.3.

FOR SECTIONS REFER TO SW-205

N.T.S.

IMPORTANT: Utility conflicts and existing conditions can create major design variables. Locate utilities and survey existing conditions prior to beginning design work.

		Proj. No.:
		Date:
Rev.:	Date:	Drawn By:

Green Streetscape Study
Oakman Blvd. Detroit, Michigan
Curb Extension SW Planter: Overflow Design

Drawing No.:
SW204

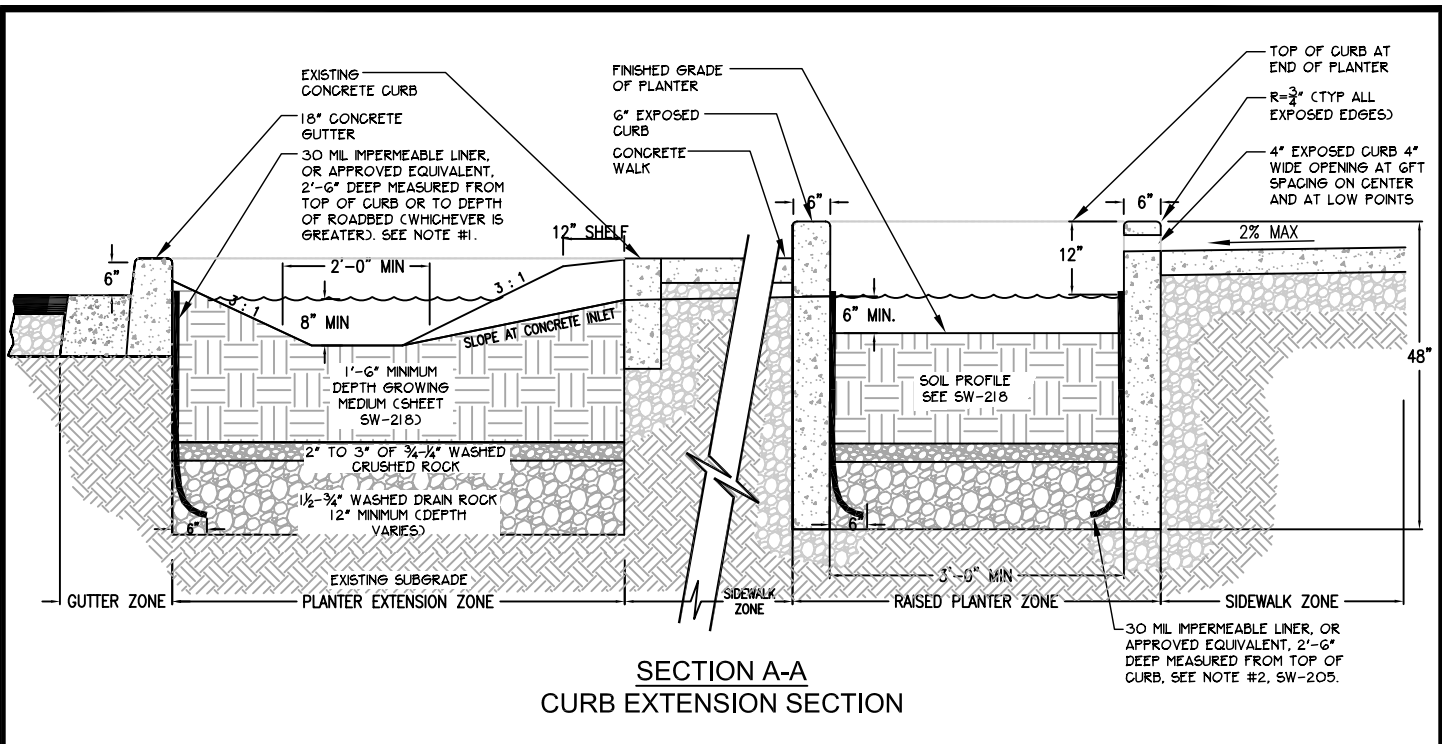

**SECTION A-A
CURB EXTENSION SECTION**

NOTES:

1. IF STORMWATER CURB EXTENSION IS CONSTRUCTED NEXT TO AN EXISTING SIDEWALK, SOIL ELEVATION MUST BE BROUGHT TO TOP OF CURB AND SLOPE AWAY FROM CURB AT A 4:1 SLOPE.
2. LINER REQUIRED WHEN FACE OF NEW CURB IS < 2FT FROM ADJACENT WATER LINE OR ON NEIGHBORHOOD COLLECTORS AND HIGHER STREET CLASSIFICATIONS. LINER MAY BE REQUIRED ON LOCAL STREETS WITH TRANSIT ROUTES, HIGHER TRAFFIC VOLUMES, OR WHEN FACILITY IS ADJACENT TO TRAVEL LANE, AT THE DISCRETION OF THE CITY ENGINEER.

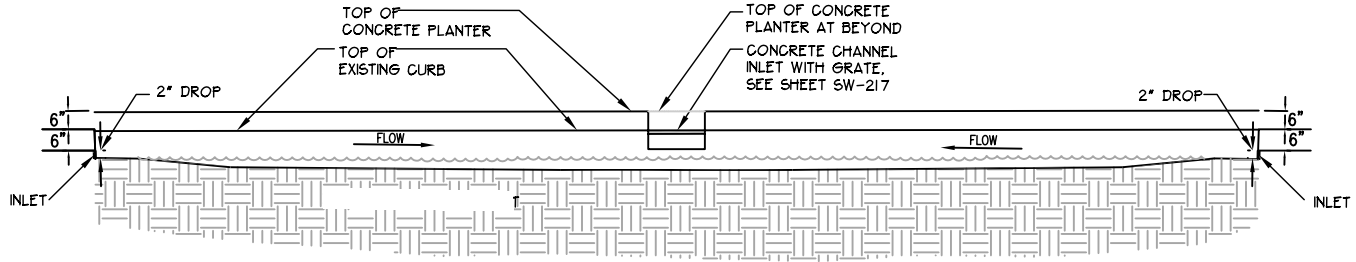

**SECTION B-B
CURB EXTENSION PROFILE**

REFER TO SW-204
N.T.S.

			Proj. No.:
			Date:
Rev.:	Date:		Drawn By:
Green Streetscape Study			Drawing No.:
Oakman Blvd. Detroit, Michigan			SW205
Curb Extension SW Planter Section: Overflow Design			

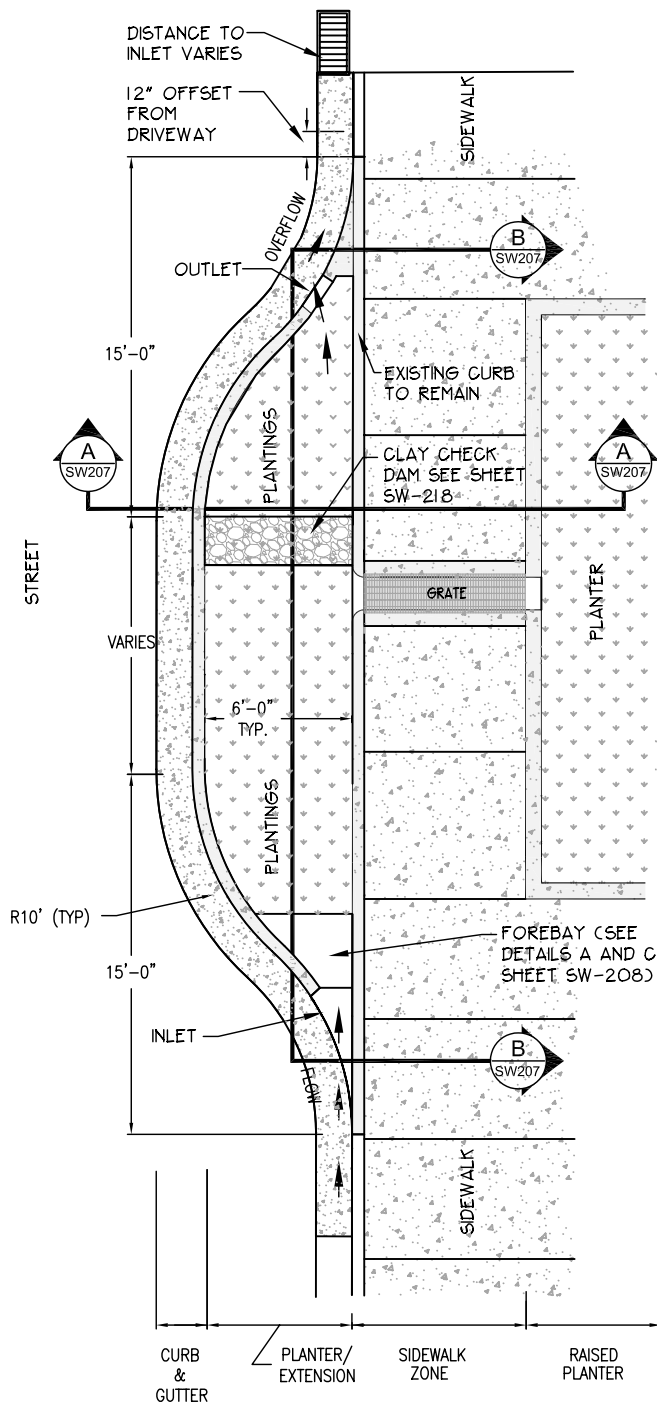

CURB EXTENSION PLAN

NOTES:

1. WIDTH OF CURB EXTENSION: 6' TO 9' TYPICAL FROM INSIDE CURBS. DEPTH OF CURB EXTENSION: 6" MIN. FROM INLET AT GUTTER ELEVATION TO BOTTOM OF FACILITY. ACTUAL WIDTH TO BE DETERMINED BY CITY ENGINEER.
2. LONGITUDINAL SLOPE OF PLANTER MATCHES ROAD: FLAT AS POSSIBLE, 3% MAXIMUM. LONGITUDINAL AND CROSS SLOPE OF SOIL WITHIN PLANTER: NONE, FLAT AS POSSIBLE. TYPICAL CROSS SLOPE OF ROAD 2% TO 6%, CROSS SLOPE OF GUTTER 8%.
3. SPECIAL REQUIREMENTS MAY BE NECESSARY ON STEEP SLOPES AND FOR FACILITIES DESIGNED TO INCLUDE DISCHARGE.
4. INCLUDE BEGINNING AND ENDING STATION ELEVATIONS FOR EACH FACILITY. PROVIDE THE TOP AND BOTTOM ELEVATION OF FACILITY AT EACH STATION SPECIFIED. INCLUDE ELEVATIONS AT EVERY INLET AND OUTLET.
5. SIDEWALK ELEVATION MUST BE SET ABOVE INLET AND OUTLET ELEVATIONS TO ALLOW OVERFLOW TO DRAIN TO STREET BEFORE SIDEWALK.
6. SEE SHEET SW-208 FOR INLET/OUTLET DETAILS.
7. CHECK DAMS REQUIRED: SEE SHEET SW-218 FOR DETAILS.
8. SEE APPENDIX SECTION 6.2 FOR GROWING MEDIUM SPECIFICATION.
9. DEPENDING ON LOCATION, UTILITY LINES MAY NEED TO BE SLEEVED.
10. CURB AND GUTTER: MDOT STANDARD ROADWAY DRAWING WITH THICKENED 12" GUTTER. USE 1'-6" WIDE GUTTER.
11. WHERE FEASIBLE, WIDTH OF STORMWATER FACILITY MAY EXTEND INTO EXISTING PLANTING STRIP (IN WHICH CASE EXISTING CURB WOULD BE REMOVED).
12. SEE PLANT LIST IN APPENDIX SECTION 6.3.

FOR SECTIONS REFER TO SW-207

N.T.S.

IMPORTANT: Utility conflicts and existing conditions can create major design variables. Locate utilities and survey existing conditions prior to beginning design work.

		Proj. No.:
		Date:
Rev.:	Date:	Drawn By:

Green Streetscape Study
Oakman Blvd. Detroit, Michigan
Curb Extension SW Planter: Flow Through Design

Drawing No.:
SW206

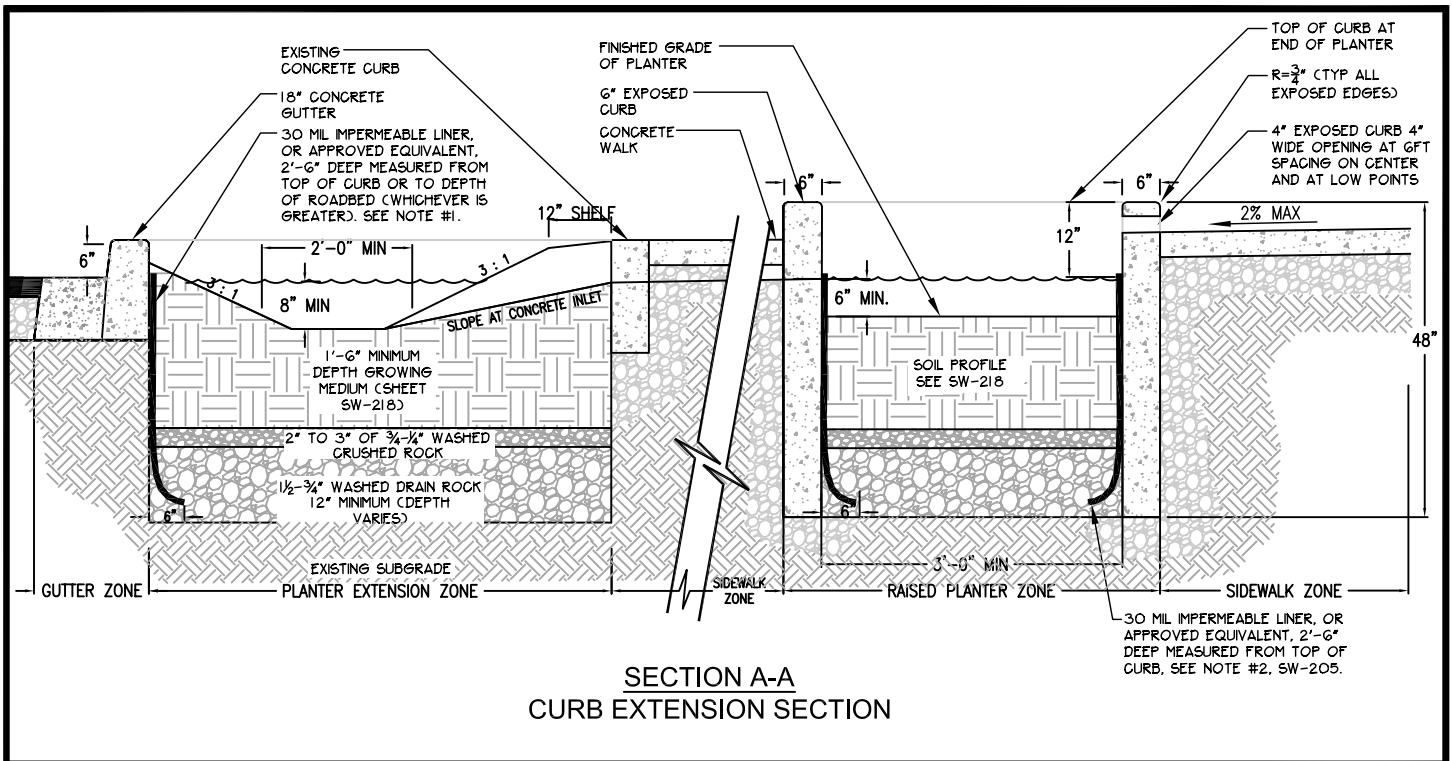

**SECTION A-A
CURB EXTENSION SECTION**

NOTES:

1. IF STORMWATER CURB EXTENSION IS CONSTRUCTED NEXT TO AN EXISTING SIDEWALK, SOIL ELEVATION MUST BE BROUGHT TO TOP OF CURB AND SLOPE AWAY FROM CURB AT A 4:1 SLOPE.
2. LINER REQUIRED WHEN FACE OF NEW CURB IS < 2FT FROM ADJACENT WATER LINE OR ON NEIGHBORHOOD COLLECTORS AND HIGHER STREET CLASSIFICATIONS. LINER MAY BE REQUIRED ON LOCAL STREETS WITH TRANSIT ROUTES, HIGHER TRAFFIC VOLUMES, OR WHEN FACILITY IS ADJACENT TO TRAVEL LANE, AT THE DISCRETION OF THE CITY ENGINEER.

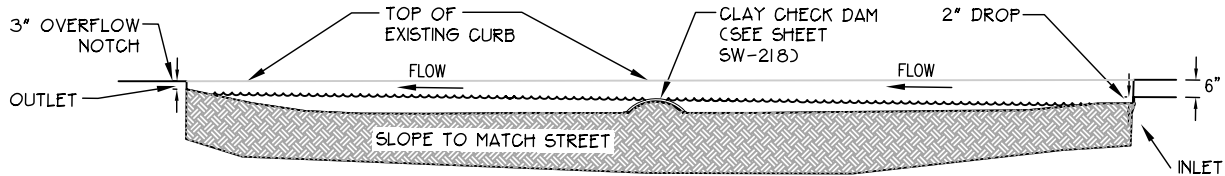

**SECTION B-B
CURB EXTENSION PROFILE**

N.T.S.

			Proj. No.:
			Date:
	Rev.:	Date:	Drawn By:
Green Streetscape Study			Drawing No.: SW207
Oakman Blvd. Detroit, Michigan			
Curb Extension SW Planter Sections: Flow Through Design			

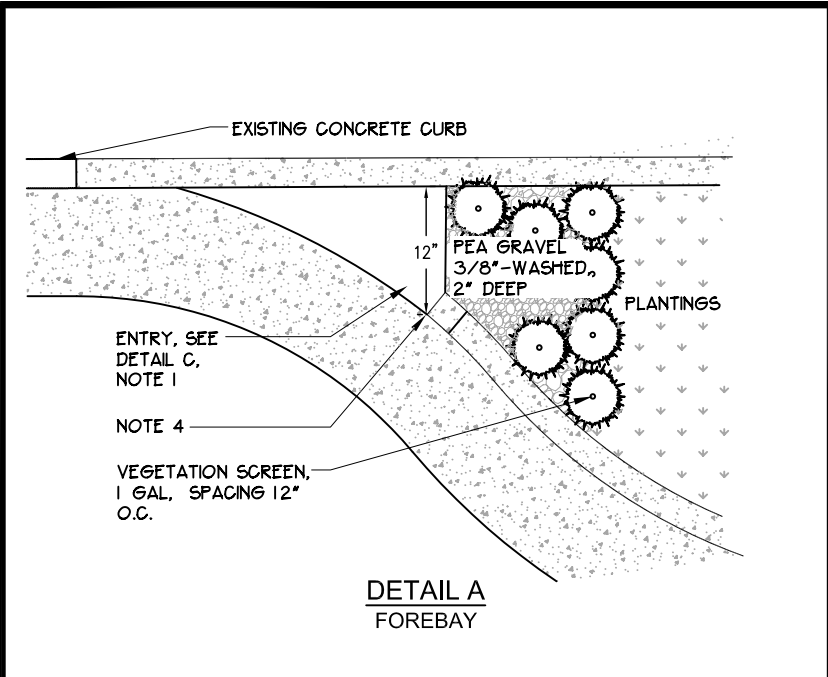

DETAIL A
FOREBAY

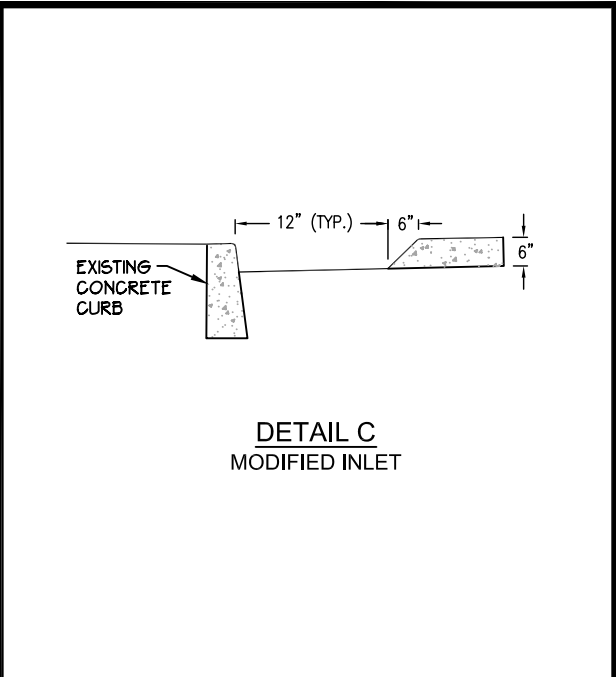

DETAIL C
MODIFIED INLET

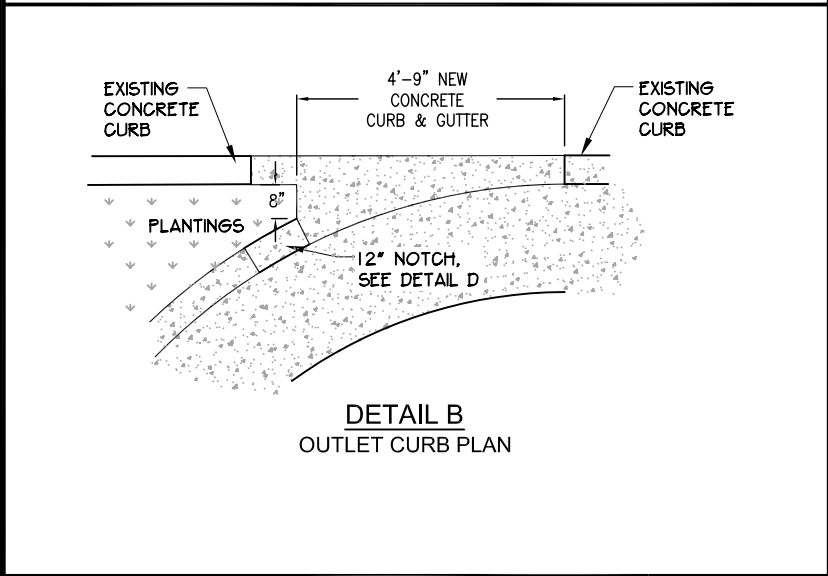

DETAIL B
OUTLET CURB PLAN

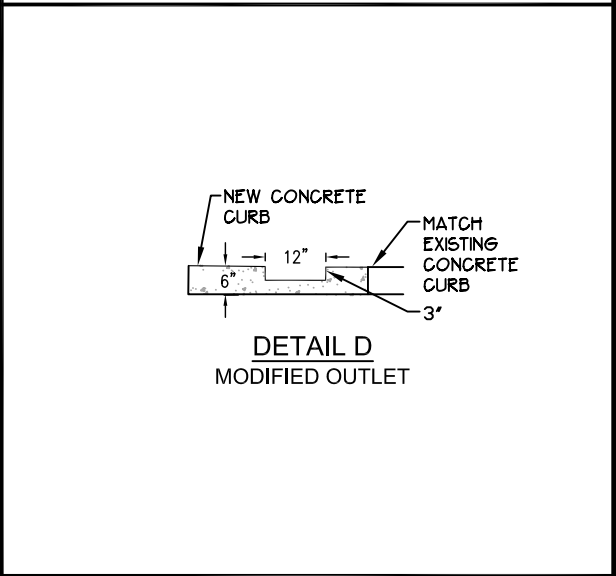

DETAIL D
MODIFIED OUTLET

NOTES

1. **DETAIL A:** PEA GRAVEL FOREBAY FOR USE WITH STORMWATER CURB EXTENSIONS ONLY. PEA GRAVEL FOREBAY REPLACES STANDARD CONCRETE SPLASH PAD.
2. **DETAIL C:** TO PREVENT PONDING, POSITION INLET CLOSER TO EXISTING CURB IF THE STREET CROSS-SLOPE IS >2%. ADDITIONAL INLETS CAN BE ADDED IF NECESSARY (PREFERABLY IMMEDIATELY DOWNSTREAM OF EACH CHECK DAM TO MINIMIZE POTENTIAL BACKFLOW). ADDITIONAL INLETS ARE NOT RECOMMENDED FOR STREETS SLOPED < 1%.
3. **DETAILS B, C AND D:** FOR USE ON LOCAL SERVICE STREETS ONLY.
4. INLET MAY BE MODIFIED TO MAXIMIZE FLOW ENTRY TO STORMWATER FACILITY.

N.T.S.

			Proj. No.:
			Date:
	Rev.:	Date:	Drawn By:
Green Streetscape Study			Drawing No.:
Oakman Blvd. Detroit, Michigan			SW208
Curb Extension SW Planter Inlet / Outlet Details			

NOTE:

LINER REQUIRED WHEN FACE OF NEW CURB IS < 2FT FROM ADJACENT WATER LINE OR ON NEIGHBORHOOD COLLECTORS AND HIGHER STREET CLASSIFICATIONS. LINER MAY BE REQUIRED ON LOCAL STREETS WITH TRANSIT ROUTES, HIGHER TRAFFIC VOLUMES, OR WHEN FACILITY IS ADJACENT TO TRAVEL LANE, AT THE DISCRETION OF THE CITY ENGINEER.

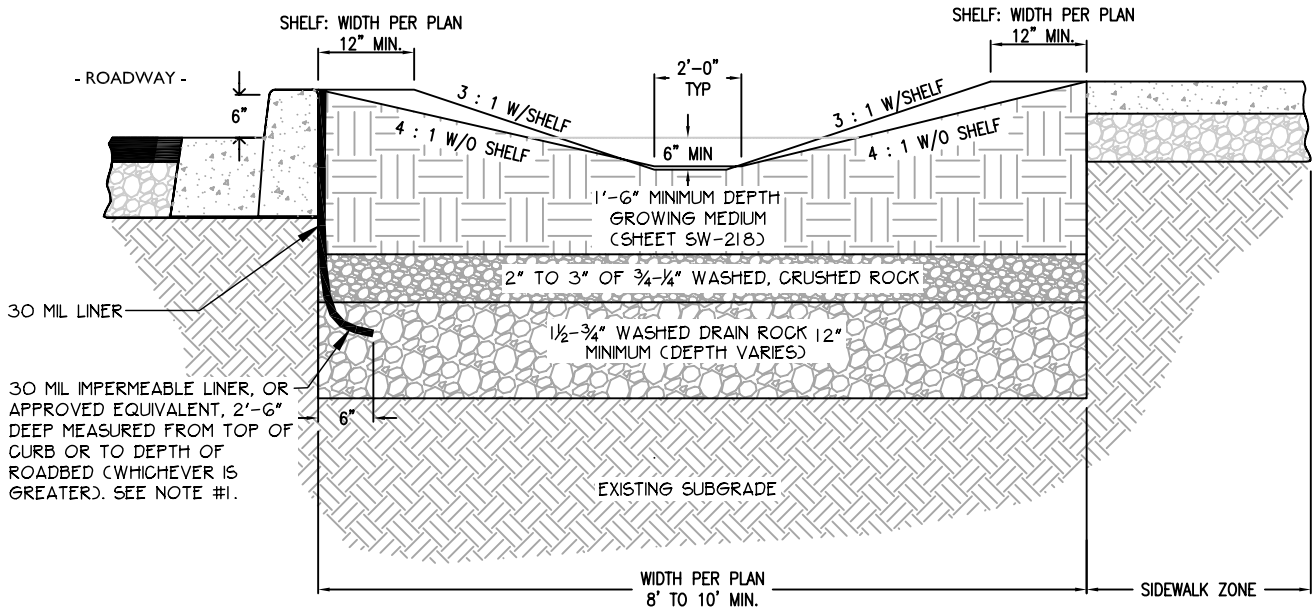

SECTION A-A
SWALE ADJACENT TO ROADWAY

N.T.S.

			Proj. No.:
			Date:
	Rev.:	Date:	Drawn By:
Green Streetscape Study			Drawing No.:
Oakman Blvd. Detroit, Michigan			SW209
Filtration Swale Sections: Adjacent to Road			

NOTES:

1. WIDTH OF PLANTER: 3' MINIMUM FROM INSIDE CURBS
LENGTH OF PLANTER BASED ON ENGINEERING CALCULATIONS: 18' TYPICAL, 12' MINIMUM. DEPTH OF PLANTER: 12" MAX. FROM TOP OF STREET CURB TO TOP OF SOIL.
2. LONGITUDINAL SLOPE OF PLANTER MATCHES ROAD: FLAT AS POSSIBLE, 3% MAXIMUM. LONGITUDINAL AND CROSS SLOPE OF SOIL WITHIN PLANTER: NONE, FLAT AS POSSIBLE. TYPICAL CROSS SLOPE OF ROAD 2-6%, CROSS SLOPE OF GUTTER 8%.
3. SPECIAL REQUIREMENTS MAY BE NECESSARY ON STEEP SLOPES AND FOR PLANTERS DESIGNED TO INCLUDE DISCHARGE.
4. INCLUDE BEGINNING AND ENDING STATION ELEVATIONS FOR EACH FACILITY. PROVIDE THE TOP AND BOTTOM ELEVATION OF FACILITY AT EACH STATION SPECIFIED. INCLUDE ELEVATIONS AT EVERY INLET AND OUTLET.
5. SIDEWALK ELEVATION MUST BE SET ABOVE INLET AND OUTLET ELEVATIONS TO ALLOW OVERFLOW TO DRAIN TO STREET BEFORE SIDEWALK.
6. SEE SHEETS SW-214-217 FOR INLET DETAILS.
7. CHECK DAMS MAY BE REQUIRED: SEE SHEET SW-218 FOR DETAILS
8. FOR PLANTING MEDIA SPECIFICATION: SEE APPENDIX SECTION 6.2.
9. SEE PLANT LISTS IN APPENDIX SECTION 6.3/
10. DEPENDING ON LOCATION, UTILITY LINES MAY NEED TO BE SLEEVED.
11. CURB AND GUTTER: MDOT STANDARD ROADWAY DRAWING WITH THICKENED 12" GUTTER. USE 1'-6" WIDE GUTTER.
12. INSTALL WASHED PEA GRAVEL OR RIVER ROCK TO TRANSITION FROM SPLASH PAD TO TOPSOIL.

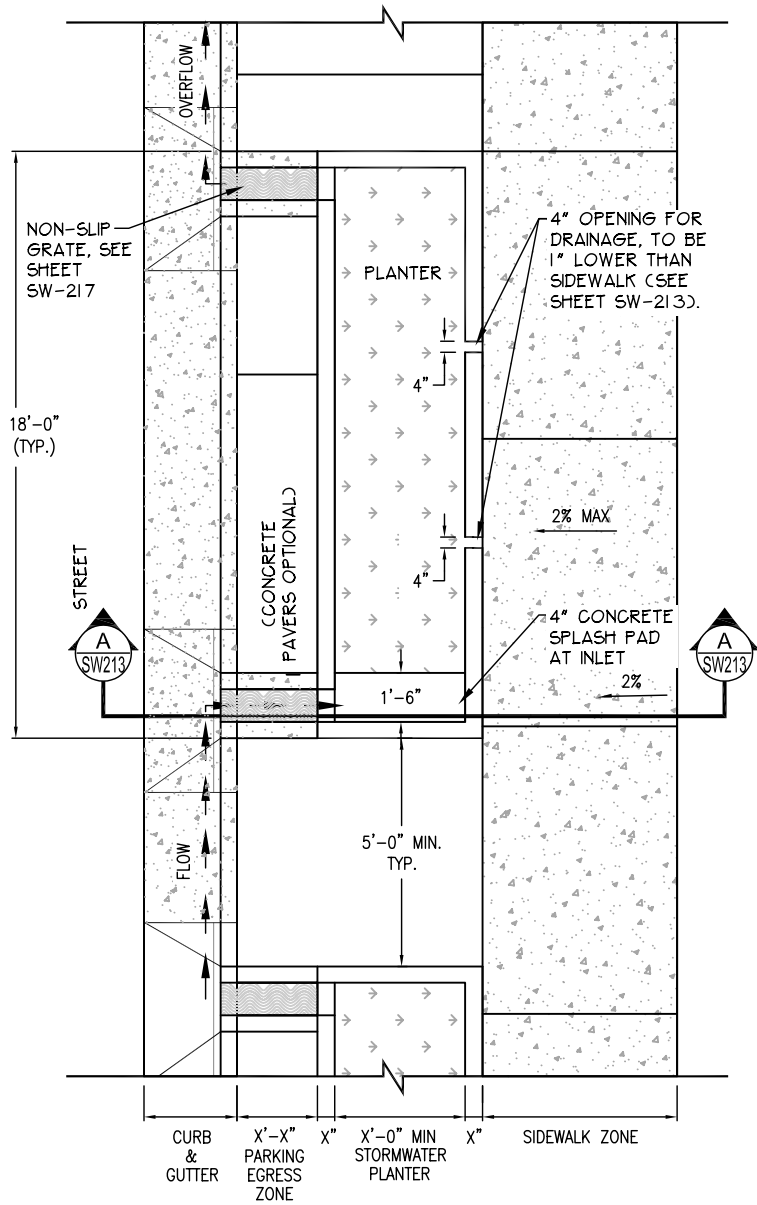

PLANTER PLAN

FOR SECTIONS REFER TO SW-213

N.T.S.

IMPORTANT: Utility conflicts and existing conditions can create major design variables. Locate utilities and survey existing conditions prior to beginning design work.

		Proj. No.:
		Date:
Rev.:	Date:	Drawn By:

Green Streetscape Study
Oakman Blvd. Detroit, Michigan
SW Planter Plan: Flow Through Design With Parking

Drawing No.:
SW210

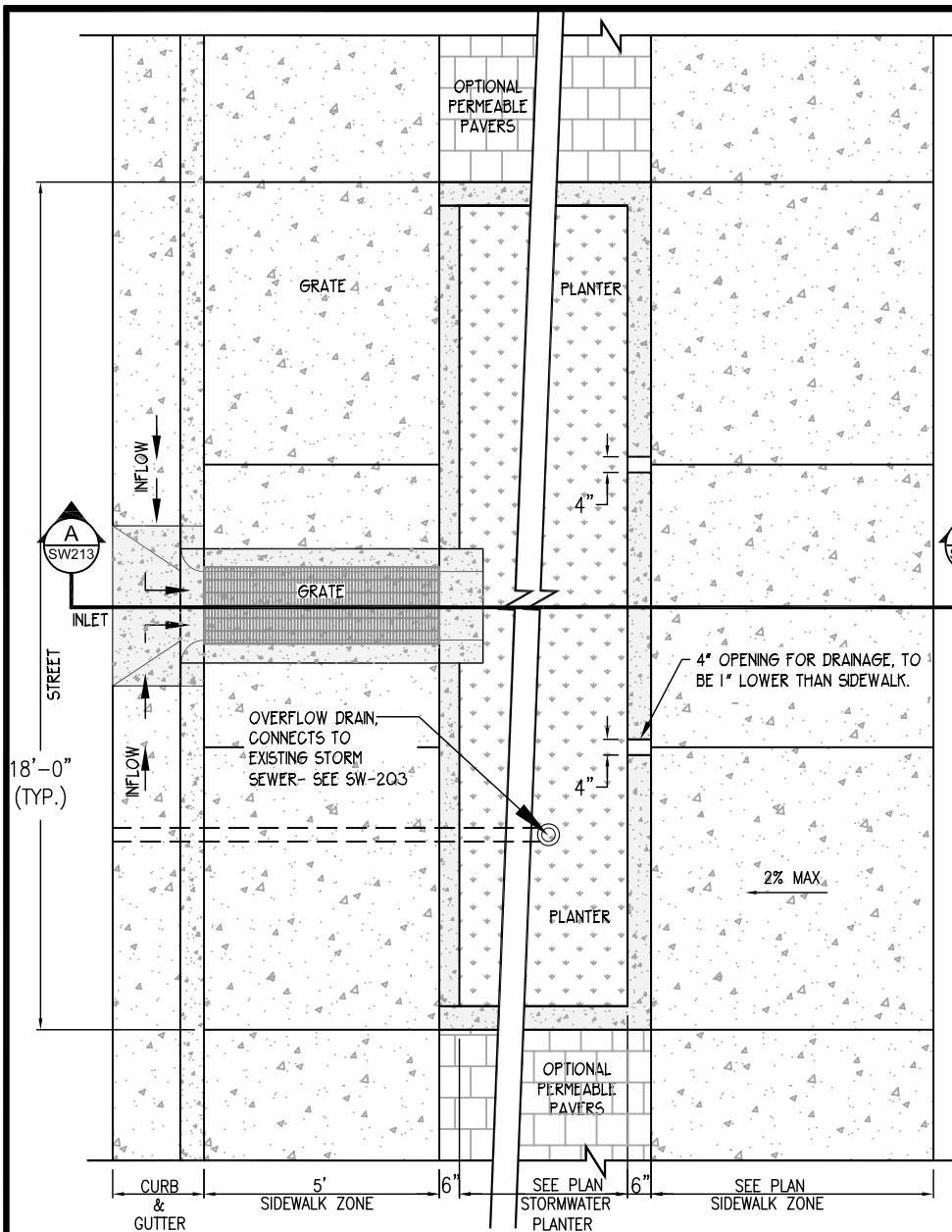

PLANTER PLAN

NOTES:

1. WIDTH OF PLANTER: 3' MINIMUM FROM INSIDE CURBS LENGTH OF PLANTER BASED ON ENGINEERING CALCULATIONS: 18' TYPICAL, 12' MINIMUM. DEPTH OF PLANTER: 12" MAX FROM TOP OF STREET CURB TO TOP OF SOIL.
2. LONGITUDINAL SLOPE OF PLANTER MATCHES ROAD: FLAT AS POSSIBLE, 3% MAXIMUM. LONGITUDINAL AND CROSS SLOPE OF SOIL WITHIN PLANTER: NONE, FLAT AS POSSIBLE. TYPICAL CROSS SLOPE OF ROAD 2-6%, CROSS SLOPE OF GUTTER 8%.
3. SPECIAL REQUIREMENTS MAY BE NECESSARY ON STEEP SLOPES AND FOR PLANTERS DESIGNED TO INCLUDE DISCHARGE.
4. INCLUDE BEGINNING AND ENDING STATION ELEVATIONS FOR EACH FACILITY. PROVIDE THE TOP AND BOTTOM ELEVATION OF FACILITY AT EACH STATION SPECIFIED. INCLUDE ELEVATIONS AT EVERY INLET AND OUTLET.
5. SIDEWALK ELEVATION MUST BE SET ABOVE INLET AND OUTLET ELEVATIONS TO ALLOW OVERFLOW TO DRAIN TO STREET BEFORE SIDEWALK.
6. SEE SHEETS SW215 AND SW217 FOR INLET DETAILS.
7. CHECK DAMS MAY BE REQUIRED: SEE SHEET SW-218 FOR DETAILS
9. SEE APPENDIX SECTION 6.2 FOR GROWING MEDIUM REQUIREMENTS.
8. CONSULT CITY ENGINEER FOR SPECIAL REQUIREMENTS FOR WATER LINES, METERS, AND FIRE HYDRANTS.
9. DEPENDING ON LOCATION, UTILITY LINES MAY NEED TO BE SLEEVED.
10. CURB AND GUTTER: MDOT STANDARD ROADWAY DRAWING WITH THICKENED 12" GUTTER. USE 1'-6" WIDE GUTTER.
11. INSTALL WASHED PEA GRAVEL OR RIVER ROCK TO TRANSITION FROM SPLASH PAD TO TOPSOIL.
15. SEE PLANT LIST IN APPENDIX SECTION 6.3.

N.T.S.

FOR SECTIONS REFER TO SW213

IMPORTANT: Utility conflicts and existing conditions can create major design variables. Locate utilities and survey existing conditions prior to beginning design work.

		Proj. No.:
		Date:
Rev.:	Date:	Drawn By:
Green Streetscape Study		Drawing No.:
Oakman Blvd. Detroit, Michigan		SW212
SW Planter Plan: Overflow Design		

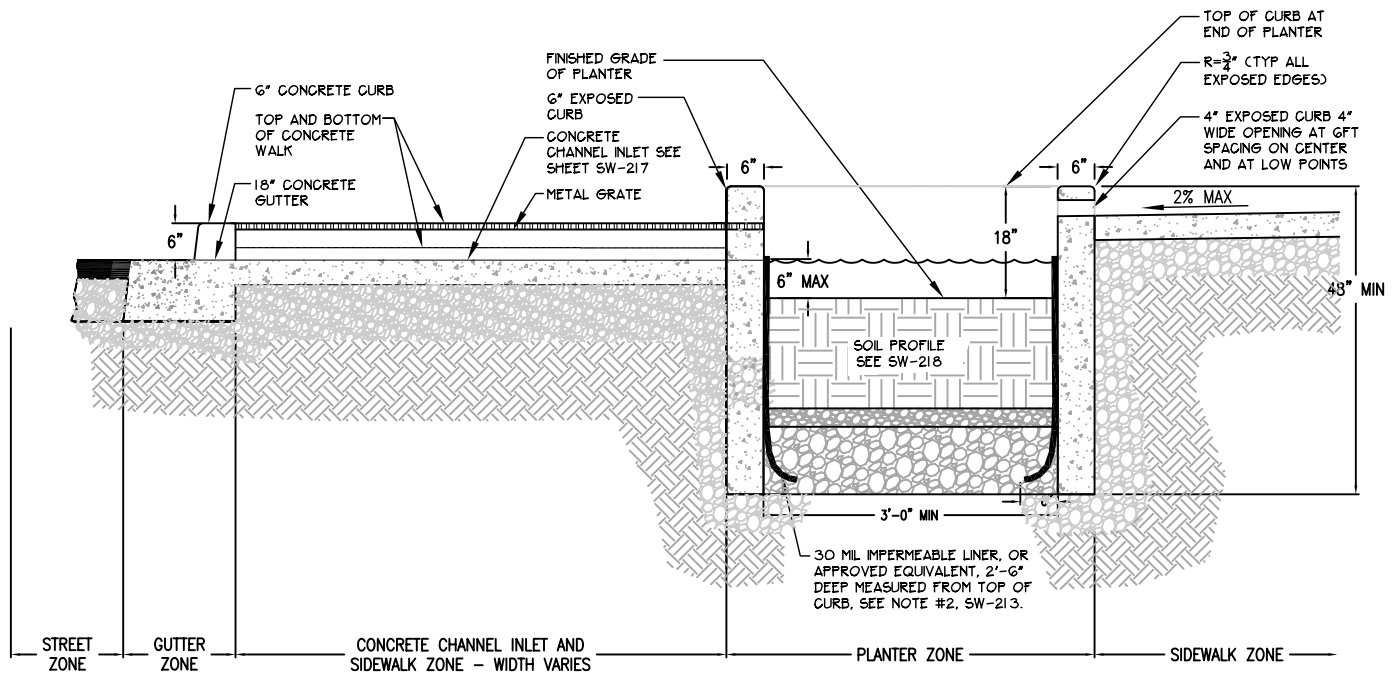

SECTION A-A
STORMWATER PLANTER SECTION

NOTES:

1. IF STORMWATER CURB EXTENSION IS CONSTRUCTED NEXT TO AN EXISTING SIDEWALK, SOIL ELEVATION MUST BE BROUGHT TO TOP OF CURB AND SLOPE AWAY FROM CURB AT A 4:1 SLOPE.
2. LINER REQUIRED WHEN FACE OF NEW CURB IS < 2FT FROM ADJACENT WATER LINE OR ON NEIGHBORHOOD COLLECTORS AND HIGHER STREET CLASSIFICATIONS. LINER MAY BE REQUIRED ON LOCAL STREETS WITH TRANSIT ROUTES, HIGHER TRAFFIC VOLUMES, OR WHEN FACILITY IS ADJACENT TO TRAVEL LANE, AT THE DISCRETION OF THE CITY ENGINEER.

N.T.S.

FOR PLAN REFER
TO SW-212

			Proj. No.:
			Date:
	Rev.:	Date:	Drawn By:
Green Streetscape Study			Drawing No.:
Oakman Blvd. Detroit, Michigan			SW213
SW Planter Sections: Overflow Design with Parking			

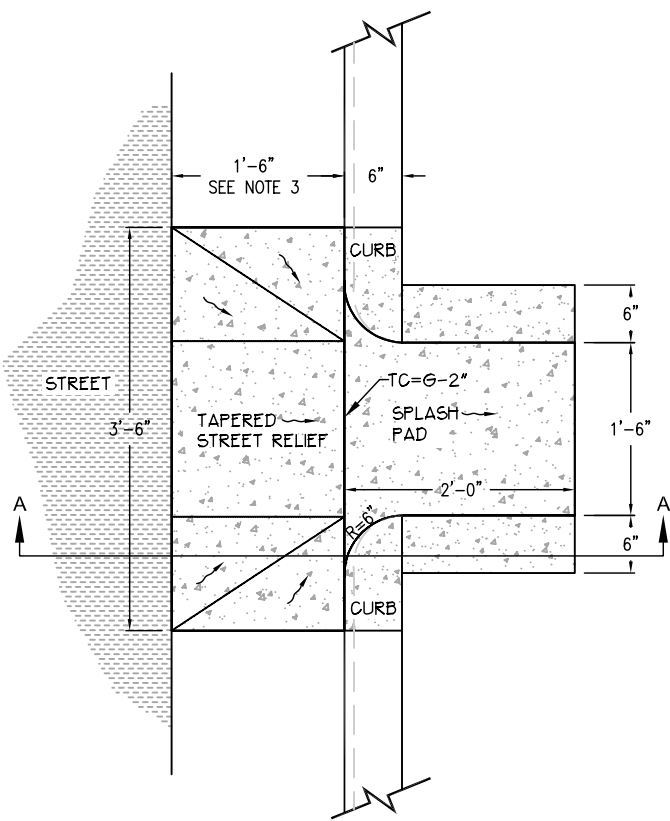

PLAN

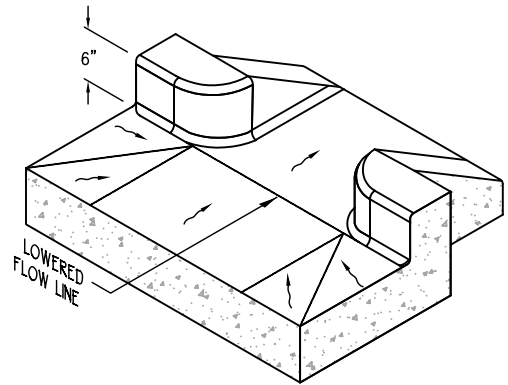

ISOMETRIC

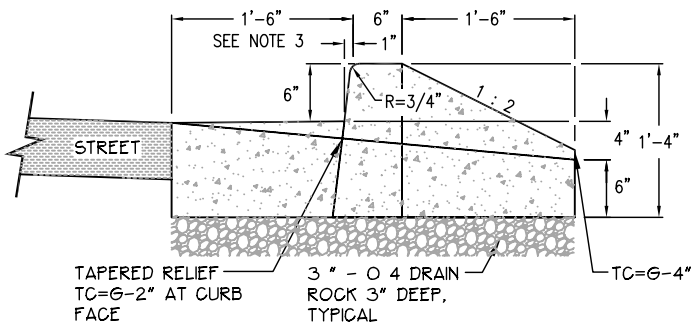

SECTION A-A

NOTES:

1. CONCRETE SPLASH PAD NECESSARY WHERE WATER ENTERS AND/OR EXITS FACILITY.
2. FOR STORMWATER FACILITIES, INSTALL WASHED PEA GRAVEL OR RIVER ROCK TO TRANSITION FROM SPLASH PAD TO TOPSOIL.
3. REFERENCE MDOT STANDARD CONCRETE GUTTER DRAWING. USE 1'-6" WIDE GUTTER, TYPICAL.

TC = TOP OF CONCRETE
G = GUTTER

N.T.S.

		Proj. No.:
		Date:
Rev.:	Date:	Drawn By:
Green Streetscape Study		Drawing No.:
Oakman Blvd. Detroit, Michigan		SW214
Concrete Inlet: For Local Service Streets		

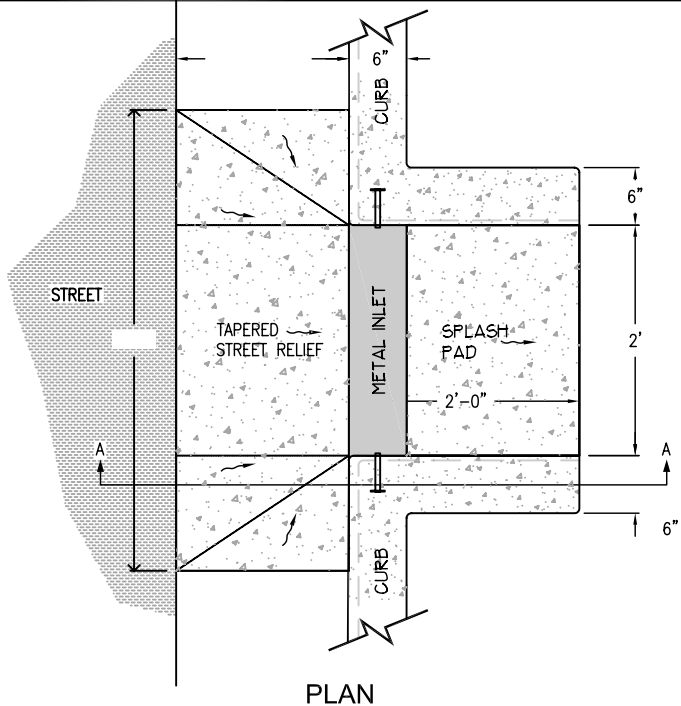

PLAN

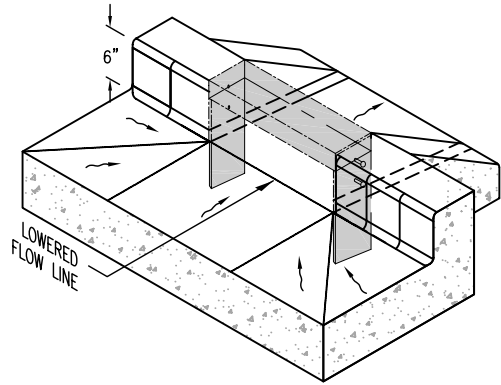

ISOMETRIC

NOTES:

1. HEADED CONCRETE ANCHORS SHALL MEET THE REQUIREMENTS OF ASTM A-108.
2. HSS G X 2 X 1/8 SHALL MEET THE REQUIREMENTS OF ASTM A-500 GRADE B.
3. END PLATES SHALL MEET THE REQUIREMENTS OF ASTM A-36.
4. ENTIRE ASSEMBLY SHALL BE HOT-DIP GALVANIZED IN ACCORDANCE WITH ASTM A-123.
5. DESIGN VERTICAL WHEEL LOAD IS 8.5KIPS (1/2 OF TANDEM AXLE WEIGHT SPECIFIED IN FHWA-HOP-06-105).
6. SINGLE BEVEL GROOVE WELD.

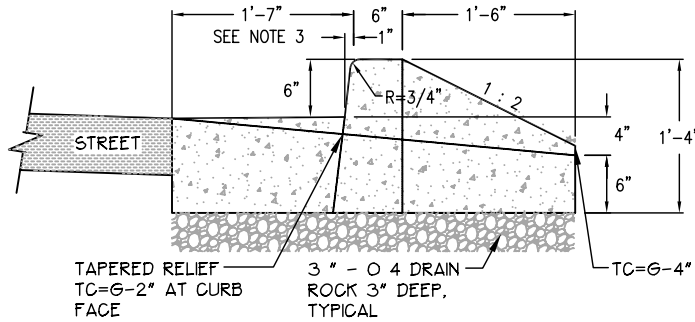

TC = TOP OF CONCRETE
G = GUTTER

SECTION A-A

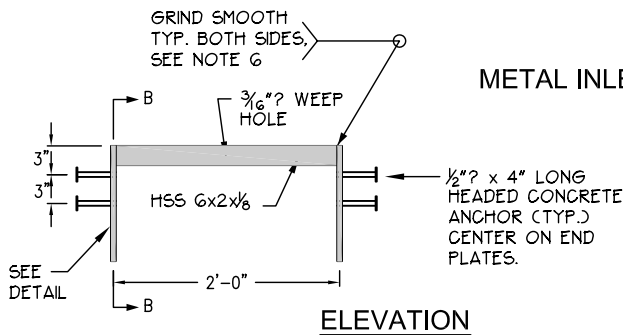

ELEVATION

METAL INLET ASSEMBLY

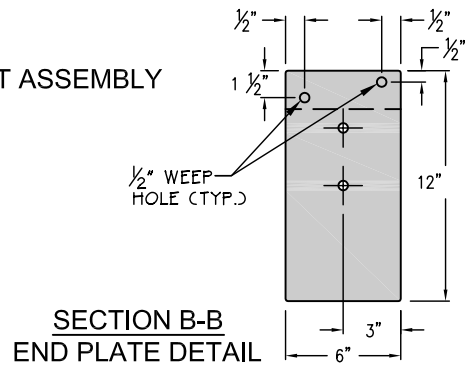

**SECTION B-B
END PLATE DETAIL**

N.T.S.

		Proj. No.:
		Date:
Rev.:	Date:	Drawn By:
Green Streetscape Study		Drawing No.:
Oakman Blvd. Detroit, Michigan		SW215
Concrete Inlet: For Collectors		

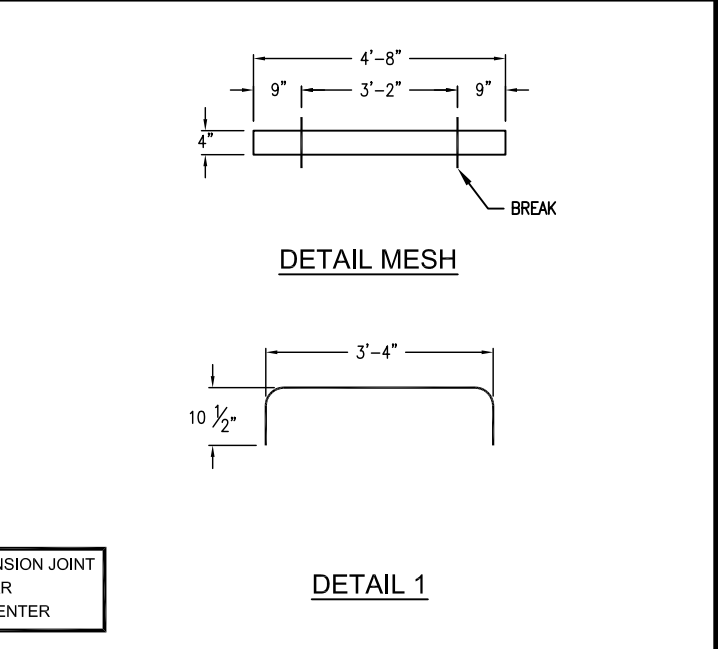
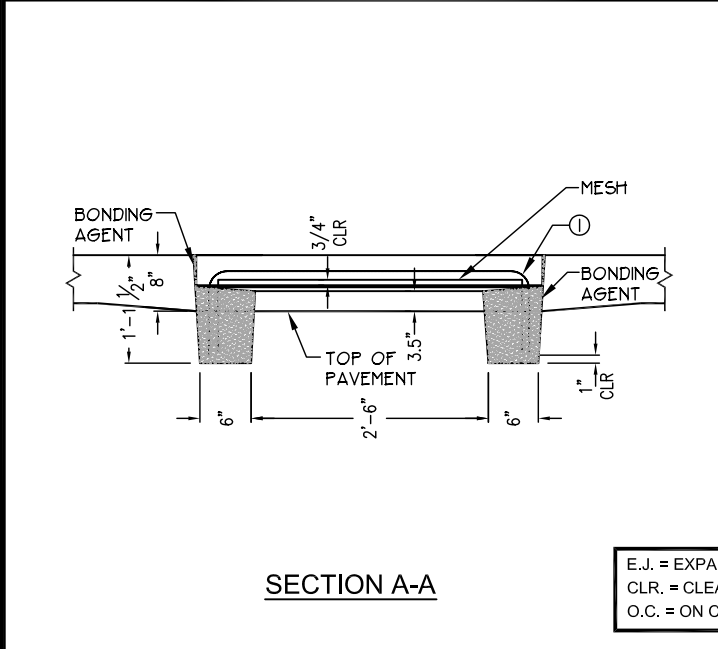
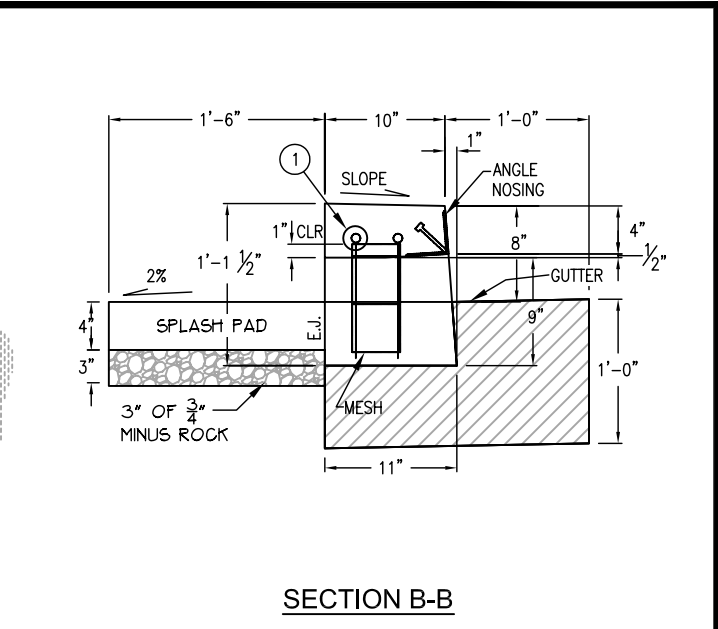
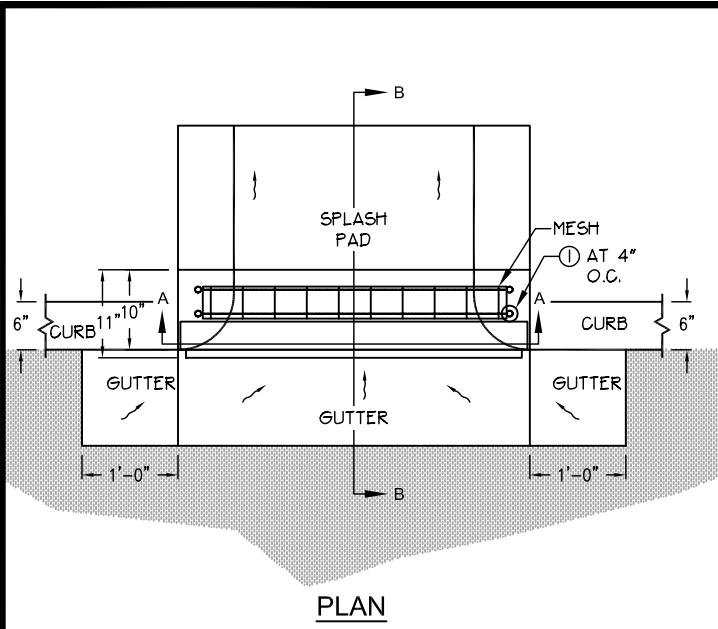

E.J. = EXPANSION JOINT
 CLR. = CLEAR
 O.C. = ON CENTER

STRUCTURAL NOTES:

1. CONCRETE: 28 DAY STRENGTH F'C = 5,500 PSI.
2. REBAR: ASTM A-615 GRADE 60.
3. MESH: ASTM A-185 GRADE G5.
4. DESIGN: ACI-318 BUILDING CODE, ASTM C-857 "MIN STRUCTURAL DESIGN LOADING FOR UNDERGROUND PRECAST CONCRETE UTILITY STRUCTURES".
5. LOADS: H-20 TRUCK WHEEL W/ 30% IMPACT.

BILL OF MATERIAL				
PART	DESCRIPTION	QTY.	SIZE	TOTAL WT. LBS.
	ANGLE NOSING	1	3.5"x3.5"x3'-7" GALV.	
MESH	W2.9/W2.9 4x4	1	SEE DETAIL MESH	2 SF
①	#6 GR 60	2	SEE DETAIL 1	15

N.T.S.

		Proj. No.:
		Date:
Rev.:	Date:	Drawn By:
Green Streetscape Study		Drawing No.: SW216
Oakman Blvd. Detroit, Michigan		
Concrete Inlet: For Collectors		

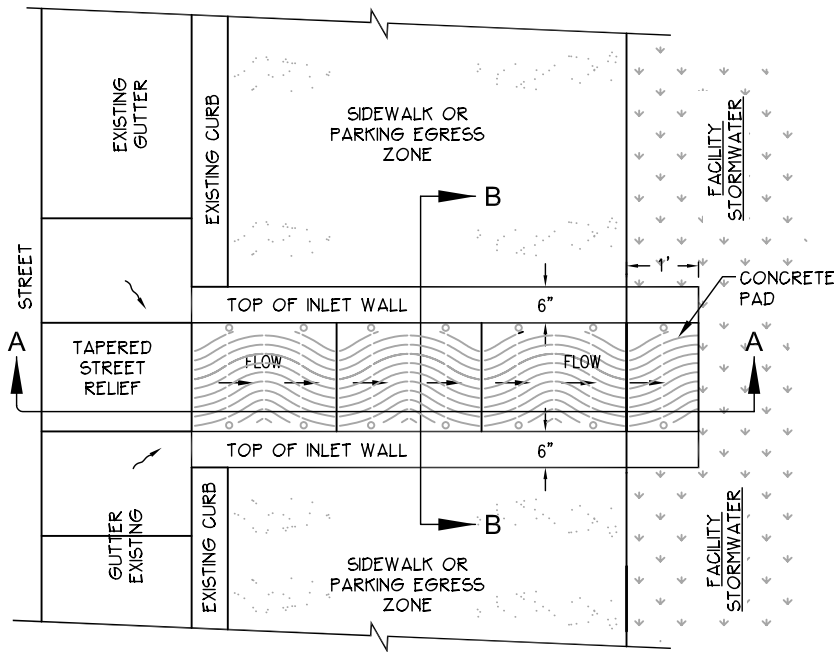

PLAN VIEW

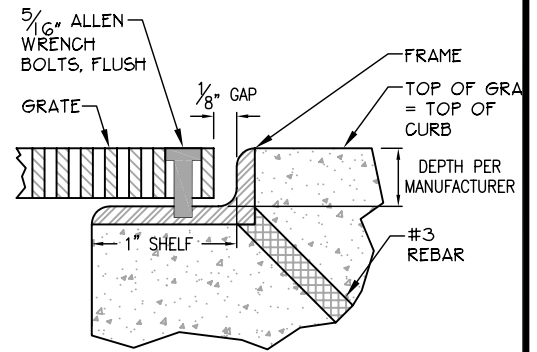

DETAIL A

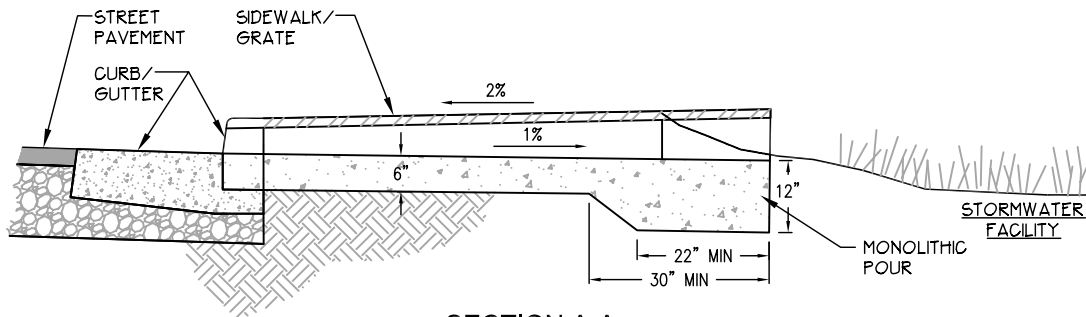

SECTION A-A

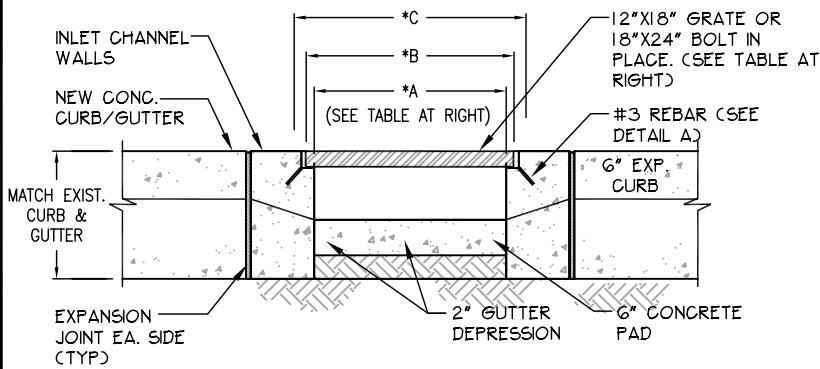

SECTION B-B

*TRENCH GRATING

A TRENCH WIDTH	B GRATE WIDTH	C FRAME WIDTH
10"	11 7/8"	12 1/8"
16"	17 7/8"	18 1/8"

NOTE: MAXIMUM GRATE HOLE WIDTH (OPEN) 1/4 INCH. GRATE SIZE 12"X18" OR 18"X24". CAST IRON URBAN ACCESSORIES TRENCH GRATE AND FRAME. TITLE WAVE MODEL OR EQUAL.

N.T.S.

Proj. No.:	
Date:	
Rev.:	Date:
Drawn By:	

Green Streetscape Study
Oakman Blvd. Detroit, Michigan
Concrete Inlet: Channel & Grate Type

Drawing No.:
SW217

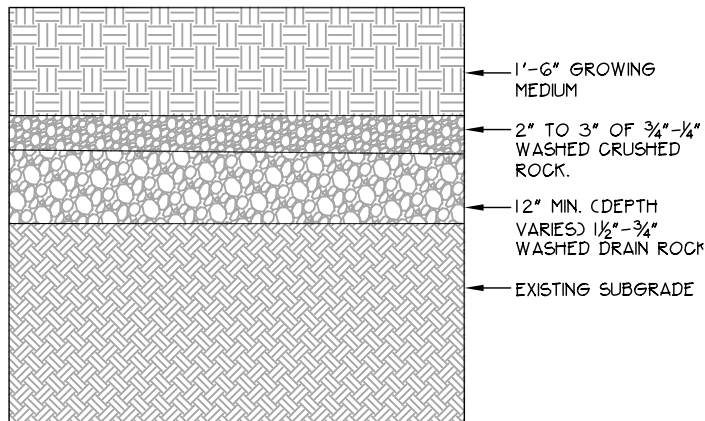

SOIL PROFILE

NOTE:
SEE APPENDIX SECTION G.2 FOR GROWING MEDIUM SPECIFICATIONS FOR VEGETATED STORMWATER FACILITIES.

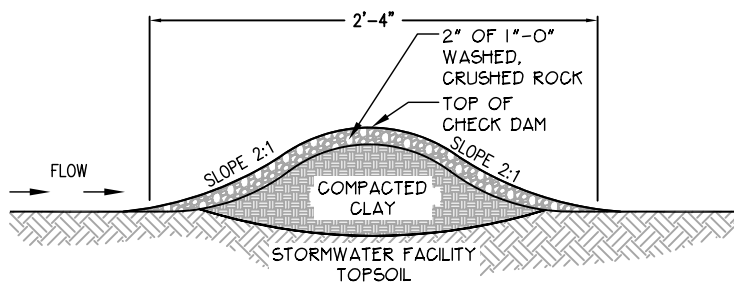

CHECK DAM

CHECK DAM SPACING			
Facility Length	Longitudinal Street Slope	# of Check Dams *	Additional Inlets **
30	<=1%	0	None
	>1%	1	None
31 - 50	<=1%	1	None
	>1%	2	1
51 - 70	<=1%	2	1
	>1%	3	2
71-90	<=1%	3	2
	>1%	4	3
91 +	<=1%	4	3
	>1%	5	4

TABLE 1

CHECK DAM NOTES:

- CHECK DAMS TO BE EVENLY SPACED BETWEEN INLET AND OUTLET. ADDITIONAL REQUIREMENTS MAYBE NECESSARY ON STEEP SLOPES.
- ADDITIONAL INLETS TO BE PLACED DIRECTLY DOWNSTREAM OF CHECK DAMS.
- TOP OF CHECK DAM TO BE 1" BELOW GUTTER ELEVATION AT INLET (CAT CURB LINE) BUT NOT GREATER THAN 2" BELOW TOP OF CURB.

N.T.S.

			Proj. No.:
			Date:
	Rev.:	Date:	Drawn By:
Green Streetscape Study			Drawing No.:
Oakman Blvd. Detroit, Michigan			
Growing Medium Profile and Check Dam			
			SW218

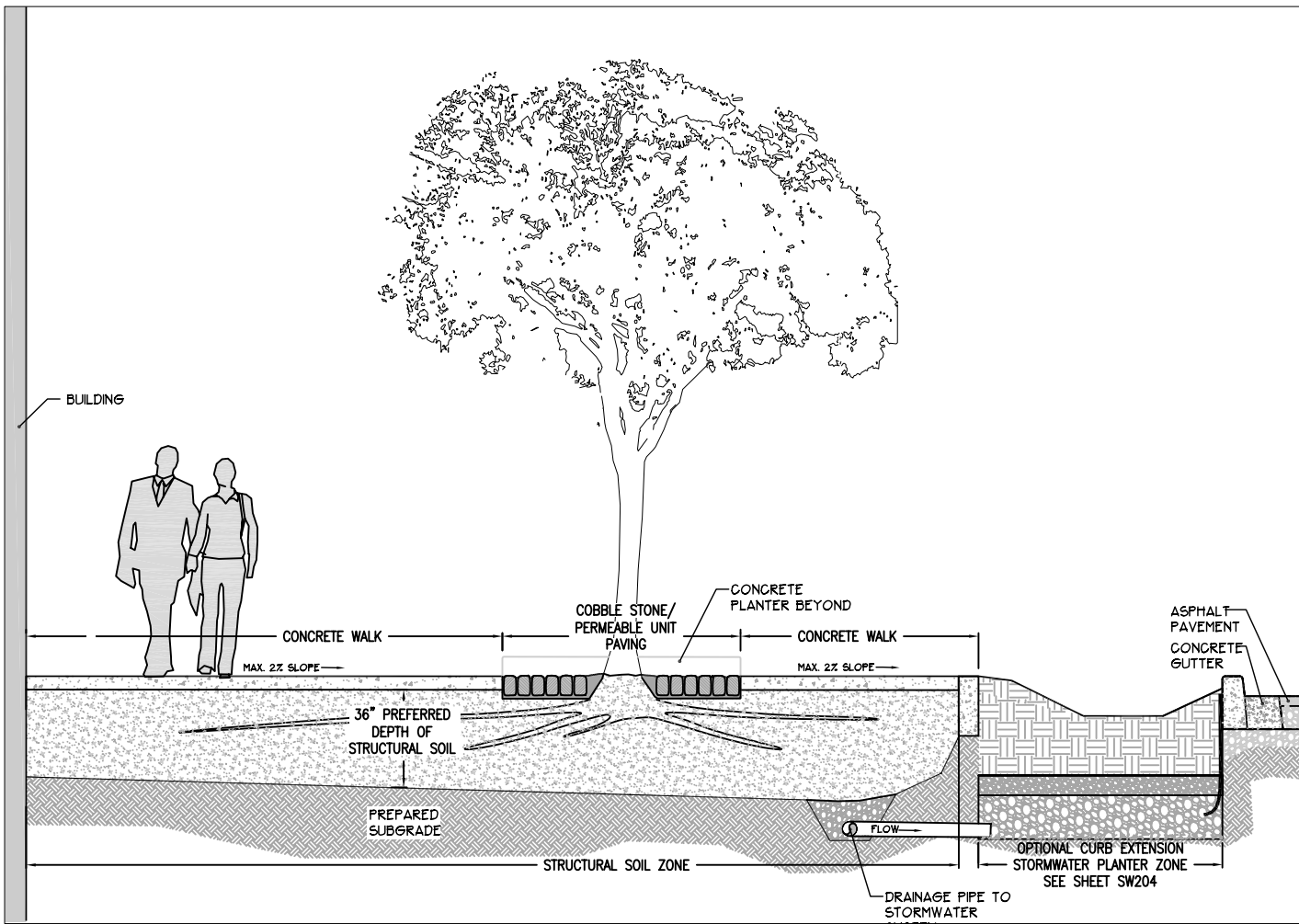

STRUCTURAL SOIL SAMPLE SPECIFICATION

CU STRUCTURAL SOIL MIX SHALL BE AS MANUFACTURED BY A SUPPLIER LICENSED BY AMERQ INC./CU SOIL DIVISION WHO HOLDS THE PATENT FOR CORNELL UNIVERSITY STRUCTURAL SOIL. THESE COMPONENTS SHALL CONFORM TO THE FOLLOWING SPECIFICATIONS:

CRUSHED GRANITE STONE: 3/4" TO 1-1/2" CRUSHED GRANITE QUARRY ROCK OF ANGULAR, SHARP TEXTURE. AASHTO #4. STONE SHALL BE CLEAN, SHARP AND FREE OF OTHER STONE OTHER THAN GRANITE. STONE SHALL BE ANGULAR IN SHARP WITH A MAXIMUM AVERAGE LENGTH, WIDTH AND DEPTH RATION OF 2:1:1. STONES WITH VISIBLE FRACTURE LINES WILL BE REJECTED. STONES SHALL HAVE A pH BETWEEN 6.0 AND 7.0, AND SOLUBLE SALT LEVELS LESS THAN 300ppm.

CLAY LOAM SOIL: TO CONFORM TO CLASS "A" TOPSOIL WITH THE FOLLOWING REVISED REQUIREMENTS:

1. GRADATION LIMITS. COARSE SAND: 0 TO 5 PERCENT, MEDIUM SAND: 10 TO 40 PERCENT, FINE SAND 0 TO 20 PERCENT. CLAY 25 TO 40 PERCENT AND SILT 20-35 PERCENT. USDA SOIL CLASSIFICATION SYSTEM.
2. CHEMISTRY LIMITS: pH BETWEEN 6.0 AND 7.8, SALINITY LESS THAN 3 ds/m, AND EXCHANGEABLE SODIUM PERCENTAGE (ESP) LESS THAN 15%.

HYDROGEL: CROSS LINKED POTASSIUM COPOLYMER HYDROGEL AS MANUFACTURED BY GELSCAPE BY AMERQ CORP., CONGERS, NY, 10920 OR BROADLEAF P4, 1041 W. 18TH STREET SUITE A103, COSTA MESA, CA 92627, (800) 628-7374, OR APPROVED EQUAL.

N.T.S.

			Proj. No.:
			Date:
	Rev.:	Date:	Drawn By:
Green Streetscape Study			Drawing No.:
Oakman Blvd. Detroit, Michigan			
Street Tree Planting in Structural Soil			
			L300

6.2. Bioretention Basin Soil Specification

The following has been developed by Low Impact Development.org through a Cooperative Assistance Agreement under the US EPA Office of Water 104b(3) Program in order to provide guidance to local governments, planners, and engineers for developing, administering, and incorporating Low Impact Development (LID) into their aquatic resource protection programs.

DESCRIPTION. Bioretention facilities are small landscaped basins intended to provide water quality management by filtering stormwater runoff before release into storm drain systems. This work shall consist of installing bioretention facilities as specified in the Contract Documents, including all materials, equipment, labor and services required to perform the work.

MATERIAL	SPECIFICATION
No. 57 Aggregate	ASTM 633 (See Comment 1)
No. 7 Aggregate	ASTM 633 (See Comment 1)
Underdrain and Outlet Pipe, 6-inch	AASHTO M278 (See Comment 1)
Mulch, 2x Shredded Hardwood Bark	See below. (See Comment 2)

Plant Materials	See below.
Water	See below.
Limestone	ASTM C25
Iron Sulfate	See below.
Magnesium Sulfate	See below.
Potash	See below. (See Comment 3)

Bioretention Soil Mixture. The Bioretention Soil Mixture (BSM) is a mixture of planting soil, mulch, and sand consisting of the following:

ITEM	COMPOSITION BY VOLUME	REFERENCE
Planting Soil	30%	See below. (See Comment 3)
Shredded 2x Hardwood Mulch	20%	See below. (See Comment 3)
Sand (clean)	50%	Michigan Department of Transportation 2NS fine aggregate

The USDA textural classification of the Planting Soil for the BSM shall be LOAMY SAND OR SANDY LOAM. The Planting Soil shall be salvaged or furnished. Additionally, the Planting Soil shall be tested and meet the following criteria:

ITEM	PERCENT BY WEIGHT	TEST METHOD
Sand (2.0 – 0.050 mm)	50 – 85%	AASHTO T88
Silt (0.050 – 0.002 mm)	0 – 50%	AASHTO T88
Clay (less than 0.002 mm)	10 – 20%	AASHTO T88
Organic Matter	1.5 – 10%	AASHTO T194

The textural analysis for the Planting Soil shall be as follows:

ASTM E11 Sieve Size	Minimum Percent Passing by Weight
2 in.	100
No. 4	90
No. 10	80

At least 45 days prior to the start of construction of bioretention facilities, the Contractor shall submit the source of the Planting Soil for the BSM to the Engineer for approval. No time extensions will be granted should the proposed Planting Soil fail to meet the minimum requirements stated above.

Once a stockpile of the Planting Soil has been sampled, no material shall be added to the stockpile. (See Comment 4)

The Bioretention Soil Mixture (BSM) shall be a uniform mix, free of stones, stumps, roots or other similar objects larger than two inches excluding mulch. No other materials or substances shall be mixed or dumped within the bioretention area that may be harmful to plant growth, or prove a hindrance to the planting or maintenance operations.

The Bioretention Soil Mixture shall be tested and meet the following criteria:

Item	Criteria	Test Method
Corrected pH	5.5 – 7.5	ASTM D4972
Magnesium	Minimum 32 ppm	*
Phosphorus (Phosphate - P ₂ O ₅)	Not to exceed 69 ppm	*
Potassium (K ₂ O)	Minimum 78 ppm	*
Soluble Salts	Not to exceed 500 ppm	*

* Use authorized soil test procedures.

Should the pH fall outside of the acceptable range, it may be modified with lime (to raise) or iron sulfate plus sulfur (to lower). The lime or iron sulfate must be mixed uniformly into the BSM prior to use in bioretention facilities.

Should the BSM not meet the minimum requirement for magnesium, it may be modified with magnesium sulfate.

Likewise, should the BSM not meet the minimum requirement for potassium, it may be modified with potash. Magnesium sulfate and potash must be mixed uniformly into the BSM prior to use in bioretention facilities.

Planting soil and/or BSM that fails to meet the minimum requirements shall be replaced at no additional cost to the Administration. Mixing of the corrective additives to the BSM is incidental and shall be at no additional cost to the Administration.

Mixing of the BSM to a homogeneous consistency shall be done to the satisfaction of the Engineer.

Placement and Compaction of the Bioretention Soil Mixture. The Bioretention Soil Mixture (BSM) shall be placed and graded using low ground-contact pressure equipment or by excavators and/or backhoes operating on the ground adjacent to the bioretention facility. *(See Comment 6)* No heavy equipment shall be used within the perimeter of the bioretention facility before, during, or after the placement of the BSM. The BSM shall be placed in horizontal layers not to exceed 12 inches for the entire area of the bioretention facility. The BSM shall be compacted by saturating the entire area of the bioretention facility after each lift of BSM is placed until water flows from the underdrain. Water for saturation shall be applied by spraying or sprinkling. Saturation of each lift shall be performed in the presence of the Engineer. An appropriate sediment control device shall be used to treat any sediment-laden water discharged from the underdrain. If the BSM becomes contaminated during the construction of the facility,

the contaminated material shall be removed and replaced with uncontaminated material at no additional cost to the Administration. Final grading of the BSM shall be performed after a 24-hour settling period. Final elevations shall be within 2 inches of elevations shown on the Contract Plans.

Notes:

Comment 1.

Double-washed stone preferred to reduce suspended solids and potential for clogging.

Comment 2.

This is to supply organic material, other sources can be used. Mulch is preferred because it can be obtained on site and it is relatively stable. Alternatively use compost

Comment 3.

Avoid high clay content soils. They tend to create hard pans and clumps that reduce filtration and storage.

Comment 4.

Allow sufficient time for testing. Suggest certified source or laboratory to reduce mobilization time and construction delays.

Comment 5.

Use of flexible slotted HDPE is preferred. Large openings on PVC pipe may allow sediments and larger materials to migrate into system.

Comment 6.

Equipment will compact bottom, reducing any infiltration capacity. The structure of the soil and pore space can be restored by aeration/rototill.

6.3. Recommended Plant Lists

The following plant lists are a sampling of recommended vegetation suitable for the use in the City of Detroit. A Landscape Architect should be consulted for designing final planting plans as correctly locating the plants is critical to their long term survival.

Wild flowers Sages and Grasses: Vegetated Stormwater Facilities

All plant material is available through Michigan Native Plant Producers Association member retailers. www.mnppa.org

Full Sun

Top (dry)

*Butterfly Weed (*Asclepias tuberosa*) – 2' – Orange – Jun-Aug – Dry-Med
 *Columbine (*Aquilegia canadensis*) – 2' – Red/yellow – Apr-Jun – Dry-Med
 Harebell (*Campanula rotundifolia*) – 1' – Purple – Jun-Sep – Dry
 Golden Alexanders (*Zizia aurea*) – 3' – Yellow – May-June – Dry-Med
 Rough Blazing Star (*Liatris aspera*) – 2' – Purple – Jul-Sep – Dry
 Skyblue Aster (*Aster oolentangiensis*) – 2-3' – Purple – Sep-Oct – Dry-Med
 Wild Geranium (*Geranium maculatum*) – 1' – Apr-July – Lavender – Dry-Med

Grasses/ Sedges

Pennsylvania Sedge (*Carex pensylvanica*) – 8" – Dry-Med
 Hosta (*Hosta sp.*) - varies
Eragrostis spectabilis (Purple Love Grass) – 1'-1.5' – Dry
 Plains Oval Sedge (*Carex brevior*) – 1' – Dry-Moist
 Little Bluestem (*Schizachyrium scoparium*) – 2-4' – Dry

Middle (medium)

Big-leaved Aster (*Aster macrophyllus*) – 1' – White – Aug-Oct – Dry-Moist
 Bishop's Cap (*Mitella diphylla*) – 1-2' – White – May-Jun – Dry-Med
 *Black-Eyed Susan (*Rudbeckia hirta*) – 2' – Yellow – Jun-Oct – Dry-Moist (use anywhere)
 Bottle Gentian (*Gentiana andrewsii*) – 3' – Blue – Aug-Sep – Dry-Moist
 Calico Aster (*Aster lateriflorus*) – 1-3' – White – Aug-Oct – Dry-Med
 Canada Anemone (*Anemone canadensis*) – 1' – White – May-Jun – Med-Wet

*Golden Alexanders (*Zizia aurea*) – 3' – Yellow – Apr-Jun – Dry-Med
 *Heath Aster (*Aster ericoides*) – 2' – White – Aug-Oct – Dry-Med
 *Nodding Onion (*Allium cernuum*) – 18" – Lavender – Jul-Aug – Dry-Moist
 *Western Sunflower (*Helianthus occidentalis*) – 3' – Yellow – July-Sep – Dry-Med

Grasses/ Sedges

Hosta (*Hosta sp.*) - varies
 Little Bluestem (*Schizachyrium scoparium*) – 3' – Dry-Med
 Prairie/Northern Dropseed (*Sporobolus heterolepis*) – 3' – Dry-Moist soil

Bottom (wet)

Aster *laevis* (Smooth Aster) – 3' – Lavender – Aug-Oct – Med-Moist
 Aster *novae-angliae* (New England Aster) – 3-6' – Purple – Sep-Oct – Dry-Med
 Early Meadow Rue (*Thalictrum dioicum*) – 2' – Green – Apr-May – Dry-Moist
 Great Blue Lobelia (*Lobelia siphilitica*) – 3' – Blue – Jul-Oct – Med-Wet
 Monkey Flower (*Mimulus ringens*) – 2' – Violet – Jun-Sep – Moist-Wet
 Northern Blue Flag Iris (*Iris versicolor*) – 3' – Blue – May-July – Med-Wet
 Black Eyed Susan (*Rudbeckia hirta*) – 1-3' – Yellow – Jul-Sep – Med-Moist
 *Rosin Weed (*Silphium integrifolium*) – 3' – Yellow – Jul-Sep – Dry-Moist
 Iris *virginica* (Blue Flag Iris) – 2-3' – Light Blue – May-July – Wet
 *Spiderwort (*Tradescantia ohioensis*) – 3' – Blue – May-July – Dry-Wet
 *Virginia Mountain Mint (*Pycnanthemum virginianum*) – 3' – White – Jun-Sep – Med-Wet
 White Snakeroot (*Eupatorium rugosum*) – 2' – White – Jul-Oct – Dry-Moist
 *Zig Zag Goldenrod (*Solidago flexicaulis*) – 3' – Yellow – Aug-Oct – Dry-Wet

Grasses/ Sedges

Juncus effusus (Soft-stemmed Rush) – 3-5' – Moist
 Common Bur/Gray's Sedge (*Carex grayi*) – 3' – Moist-Wet
 Tussock Sedge (*Carex stricta*) – 2-3' – Moist
 Palm Sedge (*Carex muskingumensis*) – 2-3' – Med-Moist
 Silky Wild Rye (*Elymus villosus*) – 3' – Dry-Moist
 Wool Grass (*Scirpus cyperinus*) – 2-3' – Wet

Partial Shade

Top (dry)

*Butterfly Weed (*Asclepias tuberosa*) – 2' – Orange – Jun-Aug – Dry-Med
 *Columbine (*Aquilegia canadensis*) – 2' – Red/yellow – Apr-Jun – Dry-Med
 Smooth Pussytoes (*Antennaria parlinii*) – 6-12" – White – May-June – Dry
 Harebell (*Campanula rotundifolia*) – 1' – Purple – Jun-Sep – Dry
 Early Goldenrod (*Solidago juncea*) – 2-4' – Yellow – Sept-Oct – Dry-Med
 Sand Coreopsis (*Coreopsis lanceolata*) – 2-3' – Yellow – June-Sep – Dry-Med
 Big-leaved Aster (*Aster macrophyllus*) – 2-3' – Purple – Sep-Oct - Dry

Wild Geranium (*Geranium maculatum*) – 1' – Apr-July – Lavender – Dry-Med

Grasses/ Sedges

Common Oak Sedge/Pennsylvania Sedge (*Carex pensylvanica*) – 8" – Dry-Med

Hosta (*Hosta sp.*) - varies

Normal Sedge (*Carex normalis*) – 1-2' – Dry-Med

Middle (medium)

Big-leaved Aster (*Aster macrophyllus*) – 1' – White – Aug-Oct – Dry-Moist

*Black-Eyed Susan (*Rudbeckia hirta*) – 2' – Yellow – Jun-Oct – Dry-Moist (use anywhere)

Calico Aster (*Aster lateriflorus*) – 1-3' – White – Aug-Oct – Dry-Med

Long-fruited thimbleweed (*Anemone cylindrica*) – 2-4' – White – May-Jun – Dry -Med

*Golden Alexanders (*Zizia aurea*) – 3' – Yellow – Apr-Jun – Dry-Med

*Heath Aster (*Aster ericoides*) – 2' – White – Aug-Oct – Dry-Med

*Nodding Onion (*Allium cernuum*) – 18" – Lavender – Jul-Aug – Dry-Moist

*Sky Blue Aster (*Aster azureus*) – 3' – Blue – Aug-Oct – Dry-Med

* Foxglove Beardtongue (*Penstemon digitalis*) – White – 3' – May-Jul – Dry-Med

* Woodland Sunflower (*Helianthus divaricatus*) – 3' – Yellow – July-Sep – Dry-

Nodding Wild Onion (*Allium cernuum*) – 18" – Pink – May-July – Dry-Moist

Grasses/ Sedges

Hosta (*Hosta sp.*) - varies

Little Bluestem (*Schizachyrium scoparium*) – 3' – Dry-Med

Prairie Sedge (*Carex bicknelii*) – 2-3' – Moist-Dry soil

Bottom (wet)

Calico Aster (*Aster lateriflorus*) – 2-4' – White – Aug-Oct – Med-Moist

Early Meadow Rue (*Thalictrum dioicum*) – 2' – Green – Apr-May – Dry-Moist

Great Blue Lobelia (*Lobelia siphilitica*) – 3' – Blue – Jul-Oct – Med-Wet

Monkey Flower (*Mimulus ringens*) – 2' – Violet – Jun-Sep – Moist-Wet

Northern Blue Flag Iris (*Iris versicolor*) – 3' – Blue – May-July – Med-Wet

*Spiderwort (*Tradescantia ohimensis*) – 3' – Blue – May-July – Dry-Wet

*Virginia Mountain Mint (*Pycnanthemum virginianum*) – 3' – White – Jun-Sep – Med-Wet

White Snakeroot (*Eupatorium rugosum*) – 2' – White – Jul-Oct – Dry-Moist

*Zig Zag Goldenrod (*Solidago flexicaulis*) – 3' – Yellow – Aug-Oct – Dry-Wet

Grasses/ Sedges

Common Bur/Gray's Sedge (*Carex grayi*) – 3' – Moist-Wet

Slender Sedge (*Carex gracillima*) – 2-3' –Med-Wet

Palm Sedge (*Carex muskingumensis*) – 2-3' – Med-Moist

Silky Wild Rye (*Elymus villosus*) – 3' – Dry-Moist

Full Shade

Top (dry)

Big-leaved Aster (*Aster macrophyllus*) – 1' – White – Aug-Oct – Dry-Moist

Columbine (*Aquilegia canadensis*) – 2' – Red/yellow – Apr-Jun – Dry-Med

Rue Anemone (*Amemonella thalictroides*) – 6" – Pink – Apr-Jun – Dry-Med

Grasses/Sedges

Common Oak Sedge/Pennsylvania Sedge (*Carex pensylvanica*) – 8" – Dry-Med

Hosta (*Hosta sp.*) - varies

Hairy Wood Sedge (*Carex hirtifolia*) – 12" – Dry-Med

Middle (medium)

Calico Aster (*Aster lateriflorus*) – 1-3' – White – Aug-Oct – Dry-Med

Golden Alexanders (*Zizia aurea*) – 3' – Yellow – Apr-Jun – Dry-Med

Thimbleweed (*Anemone virginiana*) – 2-4' – White– Jun-Aug– Moist-Dry

Heuchera americana (Alumroot) – 1'-4' – Green – June-Aug – Dry-Med

Early Meadowrue (*Thalictrum dioicum*) – 18-30" – Green – May-July – Dry-Moist

Grasses/Sedges

Hairy Wood Sedge (*Carex hirtifolia*) – 12" – Dry-Med

Hosta (*Hosta sp.*) - varies

Long-Beaked Sedge (*Carex sprengelii*) – 2' – Dry-Moist

Bottom (wet)

Calico Aster (*Aster lateriflorus*) – 2-4' –White – Sep-Oct – Wet-Moist

Early Meadow Rue (*Thalictrum dioicum*) – 2' – Green – Apr-May – Dry-Moist

Cow Parsnip (*Heracleum maximum*) – 3-7' – White – June-Aug – Wet-Moist

White Snakeroot (*Eupatorium rugosum*) – 2' – White – Jul-Oct – Dry-Moist

Zig Zag Goldenrod (*Solidago flexicaulis*) – 3' – Yellow – Aug-Oct – Dry-Wet

Grasses/Sedges

Long-awned Wood Grass (*Brachyeletrum erectum*) – 6-24" – Wet-Moist

Common Bur/Gray's Sedge (*Carex grayi*) – 3' – Moist-Wet

Slender Sedge (*Carex gracillima*) – 2-3' – Moist-Wet

Lady Fern (*Athyrium filix-femina*) – 18" – Med-Moist

Maidenhair Fern (*Adiantum pedatum*) – 2' – Med-Moist

Silky Wild Rye (*Elymus villosus*) – 3' – Dry-Moist

Medium-Large Street Trees

Common Name	Latin Name	Height	Spread	Notes
"Autmn Blaze' Freeman maple	Acer x freemanii	50-55ft	30-40ft	
Sugar Maple	Acer Saccharum	60-80ft	40-50ft	
Red maple	Acer rubrum	40-60ft		Salt sensitive, 'Red Sunset' has good flood tolerance
Upright European hornbeam	Carpinus betulus 'Fastigiata'	35ft	25ft	Salt Sensitive
Katsura tree	Cercidiphyllum japonicum	40ft		Not for compacted soils
Turkish filbert	Corylus colurna	40-50ft	20-30ft	
Gingko	Gingko biloba			Some salt tolerance
Kentucky coffee tree	Gymnocladus dioicus	60-75ft 40ft	40-50ft	
Thornless honeylocust inermis	Gleditsia triacanthos	40-100ft	40ft	
Sweetgum	Liquidambar styraciflua	70-100ft	40-65ft	Tolerates intermittent flooding
Tulip tree	Liriodendron tulipifera	80-120ft	35-50ft	Salt sensitive
Dawn redwood	Metasequoia glyptostroboides	70-100ft	25ft	Salt sensitive, Requires moist site
London planetree	Platanus x acerifolia	50ft		Salt tolerant, tolerate intermittent flooding
Amur corktree	Phellodendron amurense	30-45ft	40-50ft	
Callery pear	Pyrus calleryana	40-50ft	40ft	Tolerant of Moist & Dry Sites
Swamp white oak	Quercus bicolor			Tolerates temporary flooding, wet soils and somewhat dry soils. Salt sensitive.
		50ft	30ft	
Sawtooth oak	Quercus acutissima		45ft	Tolerates moderately dry soils. Moderate salt tolerance.
Northern pin oak	Quercus ellipsoidalis			Moisture adaptable
Bur oak	Quercus macrocarpa	40ft	40ft	Tolerates drought & intermittent flooding
Japanese pagodatree	Sophora japonica			Salt tolerant
Linden or Basswood	Tilia americana	45ft 55ft	45ft	Salt sensitive
Silver linden	Tilia tomentosa		30-50ft	
Little-leaf linden	Tilia cordata	50-60ft		Pollution tolerant
Elm hybrids	Ulmus spp.		40-50ft 25-30ft 30-50ft	Tolerates intermittent flooding and drought
Japanese zelkova	Zelkova serrata		50-80ft 40-50ft 40-50ft	

Small Street Trees

Common Name	Latin Name	Height	Spread	Notes
Hedge maple	Acer campestre	25-30ft	25-30ft	
Amur Maple	Acer ginnala	15-20ft	15-20ft	
Shantung maple	Acer truncatum	25-30ft	20-30ft	
Serviceberry	Amelanchier sp.	20-25ft	15-20ft	
American hornbeam	Carpinus caroliniana	20-30ft	20-30ft	
Amur maackia	Maackia amurensis	20-25ft		
Washington Lustre Hawthorne	Crataegus phaenopyrum 'Washington Lustre®'	20-25ft	20-25ft	
Golden Rain Tree			20ft	
Crabapple	Malus sp.	15-20ft	15-20ft	Choose disease resistant varieties**
Kwanzan Cherry	Prunus 'Kwanzan'	15-20ft	15-20ft	
Columnar Sargent Rancho Cherry	Prunus 'Columnar Sargent Rancho'	20-30ft	8-10ft	Good for narrow spaces
Common chokecherry	Prunus virginiana	20-30ft	18-25ft	Tolerant of Moist & Dry Sites
Tree Lilac	Syringa reticulata 'Ivory Silk'		15-20ft	

** - Red Jewel, Spring Snow, Snowdrift, Sumi Calocarpa, Sugar Tyme, Harvest Gold, Centurion, Prairie Fire are good Crabapples. Choose cultivars which are disease resistant and with suitable form.

25ft

Shrubs: Vegetated Stormwater Facilities

Common Name	Latin Name	Height	Spread	Notes
American Cranberrybush	Viburnum trilobum	8-12ft	8-12ft	
Black Chokeberry	Aronia prunifolia			Tolerates wet to dry soils
Common Buttonbush	Cephalanthus occidentalis	3-6ft	3-6ft	Requires wet soils
Meadowsweet	Spiraea alba			Prefers moist soils
Ninebark	Physocarpus opulifolius	12ft	12'	
Redosier Dogwood	Cornus sericea		10ft	Prefers moist soils
Shrubby Cinquefoil	Potentilla fruticosa		2-4ft	Moist but well drained soils
Shrubby St. John's-Wort	Hypericum prolificum		1-4ft	
Spicebush	Lindera benzoin		6-12ft	Moist but well drained soils
Steeplebush	Spiraea tomentosa	2-5ft		
Virginia Sweetspire	Itea virginica	5-10ft	1-4ft	Prefers moist soil
		7-9ft		
		1-4ft	2-4ft	

6-12ft

6.4. SMF Maintenance Guidelines

(SMF)Stormwater Management Facilities require more maintenance than traditional below ground stormwater infrastructure. Although none of the maintenance activates are technically difficult they are critical to the effectiveness and longevity of the SMFs. The following chart suggests several maintenance activities as well as the frequency for performing them.

Bioinfiltration/Bioretention Maintenance Guidelines	
Activity	Schedule
Water vegetation at the end of each day for two weeks after planting is completed. Water vegetation regularly to ensure successful establishment.	First year after installation or as needed during drought conditions
Inspect soil and repair eroded areas. Remove litter and debris. Clear leaves and debris from overflow.	Monthly
Inspect facility several times the first few months to ensure vegetated cover is establishing well. If not, reassess or plant an alternative species. Once established, continue to inspect semi-annually for erosion problems.	Twice Per Year
Inspect underdrain cleanout. Verify drained out time of system.	Twice Per Year
Inspect trees and shrubs to evaluate health, replace if necessary.	Twice Per Year
If rock is used as a drainage component, inspect for clogging from excess sediment.	Annually
Mow turf grass to a height of four to six inches. If native grasses are used, mow only once a year in early spring to remove dead vegetation. Mowing the native grasses the first year is critical in order to eliminate competition from annual weeds.	Turf grass -As needed Native Grasses -Annually
Remove weeds/ invasive species to ensure they don't crowd out the planted material	As needed. Minimum twice during growing season
Remulch void areas. Treat diseased trees and shrubs.	As needed
Remove sediment buildup on the bottom of facility once it has accumulated to 25 percent of original design volume.	As needed
Maintain records of all inspections and maintenance activity.	Ongoing

6.5. Streetscape SMF Sizing Guide

The following content is adapted from The New York State Stormwater Management Design Manual, April 2008. They guides offer simplified formulas for calculating the size of SMFs, Stormwater Planters and Rain Gardens, required to treat runoff from a given area.

Stormwater Planters and Rain Gardens are particularly cost effective when treating relatively small areas. The sizing of such measures is dependant on the pollutant removal goals. A generally accepted practice is to capture and treat 90% of the average annual stormwater volume. This is denoted as the Water Quality Volume. Sizing and Design guidance and example calculations on how to do this is provided in the following pages. These examples assume a basic knowledge of runoff hydrology, statistical rainfall data, and soil mechanics. While useful in determining the extent of mitigation measures required, it is strongly suggested that you consult with an engineer or landscape architect prior to implementing such practices.

Stormwater Planters

Sizing and Design Guidance

Stormwater planters should initially be sized to satisfy the WQv requirements for the impervious surface area draining to the practice. This does not apply to contained planters because

they are designed to decrease impervious area, not receive additional runoff from adjacent surfaces. The basis for the sizing guidance is the same as that for bioretention and relies on the principles of Darcy's Law, where water is passed through porous media with a given head, a given hydraulic conductivity, over a given timeframe (Flinker, 2005). The equation for sizing an infiltration or flow-through stormwater planter based upon the contributing area is as follows:

$$A_f = WQ_v \times (d_f) / [k \times (h_f + d_f)(t_f)]$$

where:

A_f = the required surface area [square feet]

Vol = the treatment volume [cubic feet]

d_f = depth of the soil medium [feet]

k = the hydraulic conductivity [in ft/day, usually set

properties of the soil media]

h_f = average height of water above the planter bed

t_f = the design time to filter the treatment volume through the filter media [usually set at 3 or 4 hours]
 4 ft/day, but can be varied depending on the [maximum 12 inches]

WQ_v = water quality volume [cubic feet]

A simple example for sizing a stormwater planter using WQv is presented the Table below. The ultimate size of a stormwater planter is a function of either the impervious area or the infiltration capacity of the media.

There are numerous sizing, siting, and material specification guidelines that should be additionally consulted during stormwater planter design.

Determine the required surface area of a stormwater planter that will be installed to treat stormwater runoff from an impervious area of 3,000 square feet, given the depth of the soil medium is 1.5 feet.

Step 1: Calculate the WQv

$$WQv = \frac{(P)(Rv)(A)}{12}$$

where:

P = 90% rainfall number = 0.9 in

Rv = $0.05 + 0.009(I) = 0.05 + 0.009(100) = 0.95$

I = percentage impervious area draining to site = 100%

A = Area draining to practice = 3,000 ft²

$$WQv = \frac{(0.9)(0.95)(3,000)}{12} \quad WQv = 213.75 \text{ ft}^3$$

Step 2: Calculate required surface area:

$$A_f = WQv \cdot (d_f) / [k \cdot (h_f + d_f)(t_f)]$$

where:

WQv = 213.75 ft³

d_f = depth of soil medium = 1.5 ft

k = hydraulic conductivity = 4 ft/day

h_f = height of water above planter bed = 0.5 ft

t_f = filter time = 0.17 days

$$A_f = \frac{(213.75)(1.5)}{[(4)(0.5+1.5)(0.17)]} \quad A_f = 235.75$$

Rain Gardens

Sizing and Design Guidance

Stormwater quantity reduction in rain gardens occurs via evaporation, transpiration, and infiltration, though only the infiltration capacity of the soil and drainage system is considered for water quality sizing. The storage volume of a rain garden is achieved within the gravel bed, soil medium and ponding area above the bed. The size should be determined using the water quality volume (WQv), where the site area is the impervious area draining to the rain garden. The following sizing criteria should be followed to arrive at the surface area of the rain garden, based on the required WQv:

$$WQv \leq V_{SM} + V_{DL} + (D_P \times ARG)$$

$$V_{SM} = ARG \times D_{SM} \times N_{SM}$$

$$V_{DL} \text{ (optional)} = ARG \times D_{DL} \times n_{DL}$$

where:

V_{SM} = volume of the soil media [cubic feet]

V_{DL} = volume of the drainage layer [cubic feet]

ARG = rain garden surface area [square feet]

D_{SM} = depth of the soil media, typically 1.0 to 1.5 feet [feet]

D_{DL} = depth of the drainage layer, typically .05 to 1.0 feet [feet]

D_P = depth of ponding above surface, maximum 0.5 feet [feet]

n_{SM} = porosity of the soil media ($\geq 20\%$)

n_{DL} = porosity of the drainage layer ($\geq 40\%$)

WQv = Water Quality Volume [cubic feet]

A simple example for sizing rain gardens based upon WQv is presented in the Table below.

Given a 1,000 square foot impervious drainage area (e.g., rooftop), a rain garden design has been proposed with a 200 square foot surface area, a soil layer depth of 12 inches, a drainage layer depth of 6 inches, and an allowable ponding depth of 3 inches. To evaluate if the proposed rain garden design satisfies site WQv requirements

Step 1: Calculate water quality volume using the following equation:

$$WQv = \frac{(P) (Rv) (A)}{12}$$

where:

P = 90% rainfall number = 0.9 in

$Rv = 0.05 + 0.009 (I) = 0.05 + 0.009(100) = 0.95$

I = Percentage impervious area draining to site = 100%

A = Area draining to practice (treatment area) = 1,000 ft²

$$WQv = \frac{(0.9)(0.95)(1,000)}{12} \quad WQv = 71.25 \text{ ft}^3$$

Step 2: Solve for drainage layer and soil media storage volume:

$$V_{SM} = ARG \times D_{SM} \times P_{SM}$$

$$V_{DL} = ARG \times D_{DL} \times P_{DL}$$

where:

ARG = proposed rain garden surface area = 200 ft²

D_{SM} = depth soil media = 12 inches = 1.0 ft

D_{DL} = depth drainage layer = 6 inches = 0.5 ft

P_{SM} = porosity of soil media = 0.20

P_{DL} = porosity of drainage layer = 0.40

$V_{SM} = 200 \text{ ft}^2 \times 1.0 \text{ ft} \times 0.20 = 40 \text{ ft}^3$

$V_{DL} = 200 \text{ ft}^2 \times 0.5 \text{ ft} \times 0.40 = 40 \text{ ft}^3$

D_P = ponding depth = 3 inches = 0.25 ft

$WQv \leq V_{SM} + V_{DL} + (D_P \times ARG) = 40 \text{ ft}^3 + 40 \text{ ft}^3 + (0.25 \text{ ft} \times 200 \text{ ft}^2)$

WQv = 71.25 ft³ ≤ 130.0 ft³, OK

Therefore, the proposed design for treating an area of 1,000 ft² satisfies the WQv requirements .

6.6. Potential LEED credits in Streetscape Development

Focus is the organization who is working in connection with local partners to redevelop the sites on both sides of Oakman Blvd. within this document’s study area. Focus is committed to employing low impact, sustainable practices in developing these sites and is investigating the feasibility of achieving LEED certification. LEED (Leadership in Energy and Environmental Design) is the most widely accepted Green building standard which provides a point or credit system for rating construction. The following is a list of LEED credits which could be achieved by employing the green streetscape elements described in this study.

- Credit SS 2. Urban Redevelopment: One point for building in urban areas with existing infrastructure, and a minimum density of 60,000 square feet per acre (two-story downtown development).
- Credit SS 3. Brownfield Development: One point can be earned for developing on a site classified as a Brownfield and conforming to EPA remediation guidelines.
- Credit SS 4. Alternative Transportation: Up to four credits can be achieved for locating the building near public transportation, providing bicycle parking, installing alternative refueling stations, minimizing parking lot size and offering preferred parking for carpools.
- Credit SS 6. Stormwater Management: Up to two credits for installing a stormwater treatment plan that: A. Generates no net increase in the rate and quantity of

stormwater run-off OR a 25 percent decrease if existing imperviousness is greater than 50 percent. B. Conforms to EPA guidelines for reducing non-point source pollution.

- Credit SS 7. Landscape and Exterior Design to Reduce Heat Islands: One or two credits for reducing heat island effect by: A. Increasing shade or using light-colored materials on 30 percent of non-roof impervious surfaces; or placing 50 percent of parking underground or using an open grid pavement system. B. Using ENERGY STAR Roof-compliant high reflectance and high emissivity roofing for at 75 percent of roofing surface OR installing a vegetated roof for at least 50 percent of roof area.
- Credit SS 8. Light Pollution Reduction: One point for installing low outdoor lighting levels and ensuring that zero direct-beam illumination leaves the building site.

How Asphalt Earns LEED Credits			
Rating Category	Credit Description	Pavement Type	Credits
SS Credit 6.1	Stormwater Design: Quantity Control	Porous Asphalt	1
SS Credit 6.2	Stormwater Design: Quality Control	Porous Asphalt	1
SS Credit 7.X	Heat Island Effect: Non-Roof	Reflective surfaces Open-graded asphalt Porous pavements	1 to 3
MR Credit 2.X	Construction Waste Management: Divert from Disposal (based on weight/volume)	RAP (Recycled Asphalt Paving)	1 to 2
ID Credit 1.X	Exceptional Performance Exceeding Expectations or Areas Not Addressed	Warm-mix asphalt High-RAP mixes	1 to 4

Figure: National Asphalt Pavement Association

References

- Bassuk, Nina. CU-Structural Soil: An Update after More than a Decade of Use in the Urban Environment. *City Trees: The Journal of the Society of Municipal Arborists*. Jan./Feb. 2008.
- Burden, Dan. Glatting Jackson and Walkable Communities Inc. Urban Street Trees, 22 Benefits, August 2006
- Emeryville, California. Stormwater Guidelines for Green, Dense Redevelopment. Retrieved February 5, 2009, from www.ci.emeryville.ca.us/planning/stormwater.html
- LEED. U.S. Green Building Council Web Site. www.usgbc.org
- Low Impact Development Center, Inc. (LID). Retrieved April 24, 2009. http://www.lid-stormwater.net/lid_techniques.htm
- Michigan DEQ. LID Manual for Michigan. SEMCOG, Detroit MI., 2008. Retrieved April 20, 2009, from http://www.michigan.gov/deq/0,1607,7-135-3308_3323-207334--,00.html
- New York DEC. New York State Stormwater Management Design Manual. Retrieved February 10, 2009, from <http://www.dec.ny.gov/chemical/29072.html>
- Pennsylvania DEP. Pennsylvania Stormwater Best Management Practices Manual. Retrieved February 10, 2009, from <http://www.depweb.state.pa.us>
- Portland, City of. 2008 Stormwater Management Manual Retrieved February 10, 2009, from <http://www.portlandonline.com/bes/index.cfm?c=47952&>
- U.S. EPA. 2005. Reducing Urban Heat Islands: Compendium of Strategies, Cool Pavements. Retrieved February 10, 2009, from www.epa.gov/heatisland/resources/pdf/CoolPavesCompendium.pdf
- U.S. EPA. 2007. Reducing Stormwater Costs through Low Impact Development (LID) Strategies and Practices. EPA 841-F-07-006. Retrieved April 2, 2008, from www.epa.gov/owow/nps/lid/costs07/documents/reducingstormwatercosts.pdf
- U.S. EPA. Case Studies for Stormwater Management on Compacted, Contaminated Soils in Dense Urban Areas Solid Waste and Emergency Response (5105T) EPA-560-F-07-232 Retrieved February 10, 2009, from www.epa.gov/brownfields
- U.S. EPA's Green Infrastructure Web site www.epa.gov/npdes/greeninfrastructure